

R22 PILOT'S OPERATING HANDBOOK

AND FAA APPROVED
ROTORCRAFT FLIGHT MANUAL

RTR 061

FAA APPROVED IN NORMAL CATEGORY BASED ON FAR 27
AND FAR 21. THIS HANDBOOK INCLUDES THE MATERIAL
REQUIRED TO BE FURNISHED TO THE PILOT BY FAR 27 AND
FAR 21 AND MUST BE CARRIED IN THE HELICOPTER AT ALL
TIMES.

HELICOPTER SERIAL NO. _____

HELICOPTER REGISTRATION NO. _____

SECTIONS 2, 3, 4 AND 5
FAA APPROVED BY:

Ronald Armstrong

CHIEF, FLIGHT TEST SECTION
ENGINEERING AND MANUFACTURING BRANCH
FEDERAL AVIATION ADMINISTRATION, WESTERN REGION

DATE: Mar. 16, 1979

ROBINSON HELICOPTER CO.
TORRANCE, CALIFORNIA

INTENTIONALLY BLANK

CLASS A
SUBSCRIPTION SERVICE

If you wish to receive future changes to the R22 Pilot's Operating Handbook and copies of future Safety Notices, you may order online at www.robinsonheli.com. The Class A subscription costs \$40 USD for a period of two years.

You may also remit your payment by filling out the contact information below and sending it and your check or money order to:

ROBINSON HELICOPTER COMPANY
2901 Airport Drive
Torrance, CA 90505

Note: The date stamped below reflects the revision of this handbook at the time it was assembled. Please refer to www.robinsonheli.com for date of most recent revision. If outdated, the most recent revision is available for an additional charge of \$20 USD.

Name: _____

Complete Address: _____

Phone: _____

E-mail: _____

Aircraft Serial Number: _____

INTENTIONALLY BLANK

**LOG OF PAGES APPROVED BY FAA
TYPE CERTIFICATE NO. H10WE**

	Page No.	Approval Date	Page No.	Approval Date
Cover Log of Pages	i	16 Mar 79		
	ii	11 May 20		
Section 2 Limitations	2-i	23 Dec 09	2-8	11 May 20
	2-1	26 Jun 12	2-9	1 Jul 05
	2-2	26 Oct 16	2-10	13 Oct 00
	2-3	5 Mar 15	2-11	13 Oct 00
	2-4	1 Jul 05	2-12	20 Jun 19
	2-5	1 Jul 05	2-13	26 Oct 16
	2-6	11 May 20	2-14	26 Oct 16
	2-7	20 Jun 19	2-15	20 Jun 19
Section 3 Emergency Procedures	3-i	11 May 20	3-6	26 Oct 16
	3-1	26 Oct 16	3-7	20 Jun 19
	3-2	21 Feb 14	3-8	13 Oct 00
	3-3	6 Jul 95	3-9	26 Oct 16
	3-4	21 Feb 14	3-10	11 May 20
	3-5	11 May 20	3-11	11 May 20
Section 4 Normal Procedures	4-i	26 Oct 16	4-8	26 Oct 16
	4-1	11 May 20	4-9	20 Jun 19
	4-2	11 May 20	4-10	26 Jun 12
	4-3	11 May 20	4-11	26 Jun 12
	4-4	11 May 20	4-12	26 Oct 16
	4-5	11 May 20	4-13	11 May 20
	4-6	21 Feb 14	4-14	26 Jun 12
	4-7	11 May 20	4-15	26 Jun 12
Section 5 Performance	5-i	23 Feb 04	5-7	13 Oct 00
	5-1	23 Feb 04	5-8	13 Oct 00
	5-2	16 Mar 79	5-9	23 Feb 04
	5-3	16 Mar 79	5-10	23 Feb 04
	5-4	15 Sep 87	5-11	23 Feb 04
	5-5	13 Oct 00	5-12	23 Feb 04
	5-6	13 Oct 00		
Section 9 Supplements	9-i	11 May 20		

Approved By: Nevada Jo Ryan Digitally signed by Nevada Jo Ryan
date: 2020.04.11 09:58:08 -0700
 Manager, West Flight Test Section, AIR-716
 Federal Aviation Administration
 Los Angeles, CA

Date of Approval: 11 May 2020

**LOG OF PAGES
NOT REQUIRING FAA APPROVAL**

	Page No.	Revision Date	Page No.	Revision Date
Section 1 General	1-i	26 Jun 12	1-5	23 Dec 09
	1-1	26 Jun 12	1-6	23 Dec 09
	1-2	26 Jun 12	1-7	5 Mar 15
	1-3	6 Jul 95	1-8	5 Mar 15
	1-4	11 May 20		
Section 6 Weight and Balance	6-i	21 Feb 14	6-5	21 Feb 14
	6-1	21 Feb 14	6-6	21 Feb 14
	6-2	21 Feb 14	6-7	21 Feb 14
	6-3	21 Feb 14	6-8	23 Feb 04
	6-4	21 Feb 14		
Section 7 Systems Description	7-i	11 May 20	7-16	21 Feb 14
	7-1	5 Mar 15	7-17	26 Oct 16
	7-2	21 Feb 14	7-18	20 Jun 19
	7-3	21 Feb 14	7-19	26 Oct 16
	7-4	21 Feb 14	7-20	26 Oct 16
	7-5	21 Feb 14	7-21	20 Jun 19
	7-6	21 Feb 14	7-22	26 Oct 16
	7-7	26 Oct 16	7-23	26 Oct 16
	7-8	21 Feb 14	7-24	11 May 20
	7-9	26 Oct 16	7-25	11 May 20
	7-10	26 Oct 16	7-26	11 May 20
	7-11	11 May 20	7-27	11 May 20
	7-12	21 Feb 14	7-28	11 May 20
	7-13	21 Feb 14	7-29	11 May 20
	7-14	21 Feb 14	7-30	11 May 20
7-15	21 Feb 14	7-31	11 May 20	
Section 8 Handling and Maintenance	8-i	20 Jun 19	8-8	20 Jun 19
	8-1	20 Jun 19	8-9	11 May 20
	8-2	20 Jun 19	8-10	11 May 20
	8-3	11 May 20	8-11	20 Jun 19
	8-4	20 Jun 19	8-12	20 Jun 19
	8-5	20 Jun 19	8-13	20 Jun 19
	8-6	20 Jun 19	8-14	20 Jun 19
	8-7	20 Jun 19		
Section 10 Safety Tips	10-i	26 Oct 16	10-4	26 Oct 16
	10-1	26 Oct 16	10-5	20 Jun 19
	10-2	26 Oct 16	10-6	20 Jun 19
	10-3	26 Oct 16		

SECTION 1

GENERAL

CONTENTS

	Page
Introduction	1-1
Cautions and Notes	1-2
Three View of R22 Helicopter	1-3
Descriptive Data	1-4
Performance Definitions	1-6
Weight and Balance Definitions	1-7
Conversion Tables	1-8

INTENTIONALLY BLANK

SECTION 1

GENERAL

INTRODUCTION

This Pilot's Operating Handbook is designed as an operating guide for the pilot. It includes the material required to be furnished to the pilot by 14 CFR parts 21 and 27. It also contains supplemental data supplied by the helicopter manufacturer.

This handbook is not designed as a substitute for adequate and competent flight instruction or for knowledge of current airworthiness directives, applicable federal aviation regulations, and advisory circulars. Nor is it intended to be a guide for basic flight instruction or a training manual. It should not be used for operational purposes unless kept in a current status.

Assuring that the helicopter is in airworthy condition is the responsibility of the owner. The pilot in command is responsible for determining that the helicopter is safe for flight. The pilot is also responsible for remaining within the operating limitations as outlined by instrument markings, placards, and this handbook.

Since it is very difficult to refer to a handbook while flying a helicopter, the pilot should study the entire handbook and become very familiar with the limitations, performance, procedures, and operational handling characteristics of the helicopter before flight.

This handbook has been divided into ten numbered sections. Limitations and emergency procedures have been placed ahead of normal procedures, performance, and other sections to provide easier access to that information. Provisions for expansion of the handbook have been made by deliberate omission of certain paragraph numbers, figure numbers, item numbers, and pages noted as being intentionally blank.

CAUTIONS AND NOTES

Cautions and Notes emphasize important information and are used as follows:

- CAUTION** Equipment damage, injury, or death can result if procedure or instruction is not followed.
- NOTE** Provides emphasis or supplementary information.

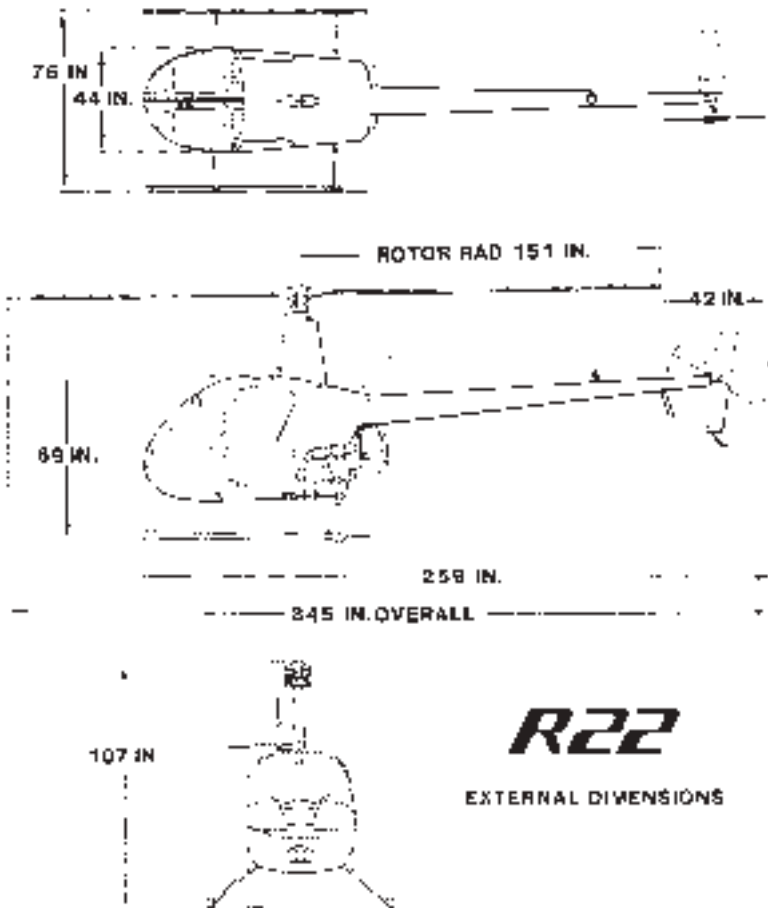

THREE-VIEW OF R22 HELICOPTER

DESCRIPTIVE DATA

MAIN ROTOR

Articulation	Free to teeter and cone, rigid inplane
Number of Blades	2
Diameter	25 feet 2 inches
Blade Chord	7.2 inches inboard, 7.7 inches outboard
Blade Twist	-8 degrees
Tip Speed at 104% RPM	698 feet per second

TAIL ROTOR

Articulation	Free to teeter, rigid inplane
Number of Blades	2
Diameter	42 inches
Blade Chord	4 inches (constant)
Blade Twist	0 degrees
Precone Angle	1 degree 11 minutes
Tip Speed at 104% RPM	622 feet per second

DRIVE SYSTEM

Engine to Upper Sheave:	Two double Vee-belts with .8536:1 speed reducing ratio
Upper Sheave to Drive Line:	Sprag-type overrunning clutch
Drive Line to Main Rotor:	Spiral-bevel gears with 11:47 speed reducing ratio
Drive Line to Tail Rotor:	Spiral-bevel gears with 3:2 speed increasing ratio

DESCRIPTIVE DATA (cont'd)

POWERPLANT

Model: Lycoming O-320 or O-360

Type: Four cylinder, horizontally opposed, direct drive
air cooled, carbureted, normally aspirated

Displacement: 319.8 (O-320) or 361.0 (O-360) cubic inches

Normal rating:

O-320-A2B or A2C	150 BHP @ 2700 RPM (Standard R22)
O-320-B2C	160 BHP @ 2700 RPM (R22 HP, Alpha, and Beta)
O-360-J2A	145 BHP (derated) @ 2700 RPM (R22 Beta II)

Maximum continuous rating in R22: 124 BHP at 2652 RPM
(1104% on tachometer)

5 minute takeoff rating for Beta and Beta II only: 131 BHP at 2652 RPM

Cooling system: Direct drive squirrel-cage blower

FUEL

Approved fuel grades and capacity: See Section 2.

OIL

Approved oil grades and capacity: See Section 8.

PERFORMANCE DEFINITIONS

KIAS	Knots Indicated Airspeed is speed shown on the airspeed indicator
KCAS	Knots Calibrated Airspeed is speed shown on the airspeed indicator corrected for instrument and position error. (See page 5-2 for position error correction.)
KTAS	Knots True Airspeed is airspeed relative to undisturbed air. It is KCAS corrected for pressure altitude and temperature.
V_{NE}	Never-Exceed Airspeed.
V_C	Speed for best rate of climb
MSL Altitude	Altitude above sea level, in feet, indicated by the altimeter (corrected for position and instrument error) when the barometric subscale is set to the atmospheric pressure existing at sea level.
Pressure Altitude	Altitude, in feet, indicated by the altimeter (corrected for position and instrument error) when the barometric subscale is set to 29.92 inches of mercury (1013.2 mb).
Density Altitude	Altitude, in feet, in ISA conditions at which the air would have the same density (it is pressure altitude corrected for OAT).
ISA	International Standard Atmosphere exists when pressure is 29.92 inches of mercury at sea level, temperature is 15°C at sea level, and temperature decreases 1.98°C per 1000 feet of altitude.
BHP	Brake Horsepower is actual power output of the engine.
MAP	Manifold Pressure is the absolute pressure, in inches of mercury, in the engine intake manifold.
RPM	Revolutions Per Minute or speed of engine or main rotor. (Shown by tachometer as percentage of 2550 engine RPM or 510 main rotor RPM).
MCP	Maximum Continuous Power.
TOP	Takeoff Power (usually for a maximum of 5 minutes).
Critical Altitude	Altitude at which full throttle produces maximum allowable power (MCP or TOP).
TOWG	Takeoff Gross Weight.

PERFORMANCE DEFINITIONS (cont'd)

OAT	Outside Air Temperature
CAT	Carburetor Air Temperature
CHT	Cylinder Head Temperature
GPH	Gallons Per Hour
AGL	Above Ground Level
IGE	In Ground Effect
OGF	Out of Ground Effect
ALT	Alternator

WEIGHT AND BALANCE DEFINITIONS

Reference Datum	A vertical plane from which horizontal distances are measured for balance purposes. The longitudinal reference datum is 100 inches forward of the main rotor shaft centerline for the R22.
Station	Fore-and-aft location along the helicopter fuselage given in terms of distance in inches from the longitudinal reference datum.
Arm	Horizontal distance from a reference datum to the center of gravity (CG) of an item.
Moment	The weight of an item multiplied by its arm.
Center of Gravity (CG)	Location along the fuselage (usually expressed in inches from the reference datum) at which the helicopter would balance. CG is calculated by dividing the total helicopter moment by total helicopter weight.
CG Limits	Extreme CG locations within which the helicopter must be operated at a given weight.
Usable Fuel	Fuel available for flight planning.
Unusable Fuel	Fuel remaining in the tank that cannot reliably provide uninterrupted fuel flow in the critical flight attitude.
Standard Empty Weight	Weight of standard helicopter including unusable fuel, full operating fluids, and full engine oil.
Basic Empty Weight	Standard empty weight plus weight of installed optional equipment.
Payload	Weight of occupants, cargo, and baggage.
Useful Load	Difference between maximum gross weight and basic empty weight.

CONVERSION TABLES

METRIC TO ENGLISH

<u>Multiply</u>	<u>By</u>	<u>To Obtain</u>
centimeters (cm)	0.3937	inches (in)
kilograms (kg)	2.2046	pounds (lb)
kilometers (km)	0.5400	nautical miles (nm)
kilometers (km)	0.6214	statute miles (mi)
liters (l)	0.2642	gallons, U.S. (gal)
liters (l)	1.0567	quarts (qt)
meters (m)	3.2808	feet (ft)
millibars (mb)	0.0295	inches mercury (in. Hg)

ENGLISH TO METRIC

<u>Multiply</u>	<u>By</u>	<u>To Obtain</u>
feet (ft)	0.3048	meters (m)
gallons, U.S. (gal)	3.7854	liters (l)
inches (in)	2.5400	centimeters (cm)
inches (in)	25.4000	millimeters (mm)
inches mercury (in. Hg)	33.8638	millibars (mb)
nautical miles (nm)	1.8520	kilometers (km)
pounds (lb)	0.4536	kilograms (kg)
quarts (qt)	0.9464	liters (l)
statute miles (mi)	1.6093	kilometers (km)

1 nautical mile = 1.1508 statute miles

1 statute mile = 0.8690 nautical mile

TEMPERATURE

$$^{\circ}\text{F} = 9/5 (^{\circ}\text{C}) + 32$$

$$^{\circ}\text{C} = 5/9 (^{\circ}\text{F} - 32)$$

**SECTION 2
LIMITATIONS
CONTENTS**

	Page
General	2-1
Color Code for Instrument Markings	2-1
Airspeed Limits	2-1
Rotor Speed Limits	2-2
Powerplant Limitations	2-2
Weight Limits	2-3
Center of Gravity Limits	2-3
Flight and Maneuver Limitations	2-6
Kinds of Operation Limitations	2-7
Fuel Limitations	2-7
Instrument Markings	2-8
Placards	2-10
Information per FAA AD 95-26-04	2-15

INTENTIONALLY BLANK

**SECTION 2
LIMITATIONS**

GENERAL

This section includes operating limitations, instrument markings, and basic placards required for safe operation of the helicopter, its engine, and other standard systems. The helicopter is approved as a normal category rotorcraft under FAA Type Certificate No. H10WE as Models R22, R22 Alpha, R22 Beta, and R22 Mariner.

COLOR CODE FOR INSTRUMENT MARKINGS

- | | |
|--------|--|
| Red | Operating limit. Edge of red line indicates limit. Pointer should not enter red during normal operation. |
| Yellow | Precautionary or special operating procedure range. |
| Green | Normal operating range. |

AIRSPEED LIMITS

NEVER-EXCEED AIRSPEED (V_{NE})

Up to 3000 feet density altitude: 102 KIAS

Above 3000 feet density altitude, see placards on page 2-11.

ROTOR SPEED LIMITS

	TACHOMETER READING	ACTUAL RPM
Power On		
Maximum	104%	530
Minimum*	101% **	515
Power Off		
Maximum	110%	561
Minimum	90%	459

*Transient operation at lower RPM permitted for emergency procedures training.

**97% (495 RPM) permitted on R22s with O-320 engine and tachometer with 97% to 104% green arc installed.

POWERPLANT LIMITATIONS

ENGINE

One Lycoming Model O-320 or O-360

OPERATING LIMITS

Engine Maximum Speed 2652 RPM (104%)

Cylinder Head Max Temperature 500°F (260°C)

Oil Maximum Temperature 245°F (118°C)

Oil Pressure***

 Minimum during idle 25 psi

 Minimum during flight 55 psi

 Maximum during flight 95 psi

 Maximum during start & warm up 115 psi

Oil Quantity, minimum for takeoff 4 qt (3.8 liters)

Manifold Pressure: See placards on pages 2-10 and 2-11 for MAP schedules.

***These limits apply to all engines. Earlier oil pressure gages show green arc from 60 to 90 psi and red line at 100 psi. Regulations require that limits indicated by installed gage are not exceeded.

WEIGHT LIMITS

Maximum gross weight – Standard & HP	1300 lb (590 kg)
Maximum gross weight – Alpha, Beta, and Beta II	1370 lb (622 kg)
Minimum gross weight	920 lb (417 kg)
Maximum per seat including baggage compartment	240 lb (109 kg)
Maximum in either baggage compartment	50 lb (23 kg)

CENTER OF GRAVITY LIMITS

See figures on pages 2-4 and 2-5. Reference datum is 100 inches forward of main rotor shaft centerline.

NOTE

With both doors installed, a solo pilot plus baggage weight of 135 lb (61 kg) or greater will ensure CG within limits. For lower weight, compute weight and balance; removable ballast may be required to obtain CG at or forward of aft limit. (See Loading Instructions in Section 6.)

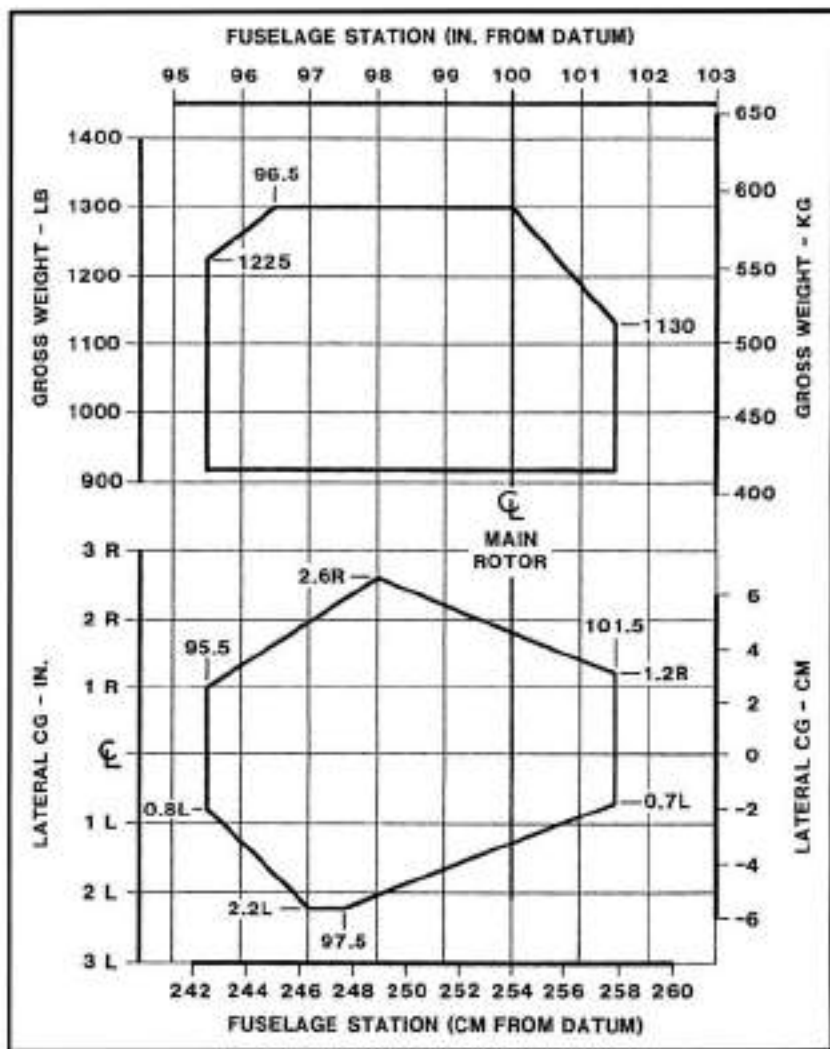

R22 STANDARD AND HP
CENTER OF GRAVITY LIMITS

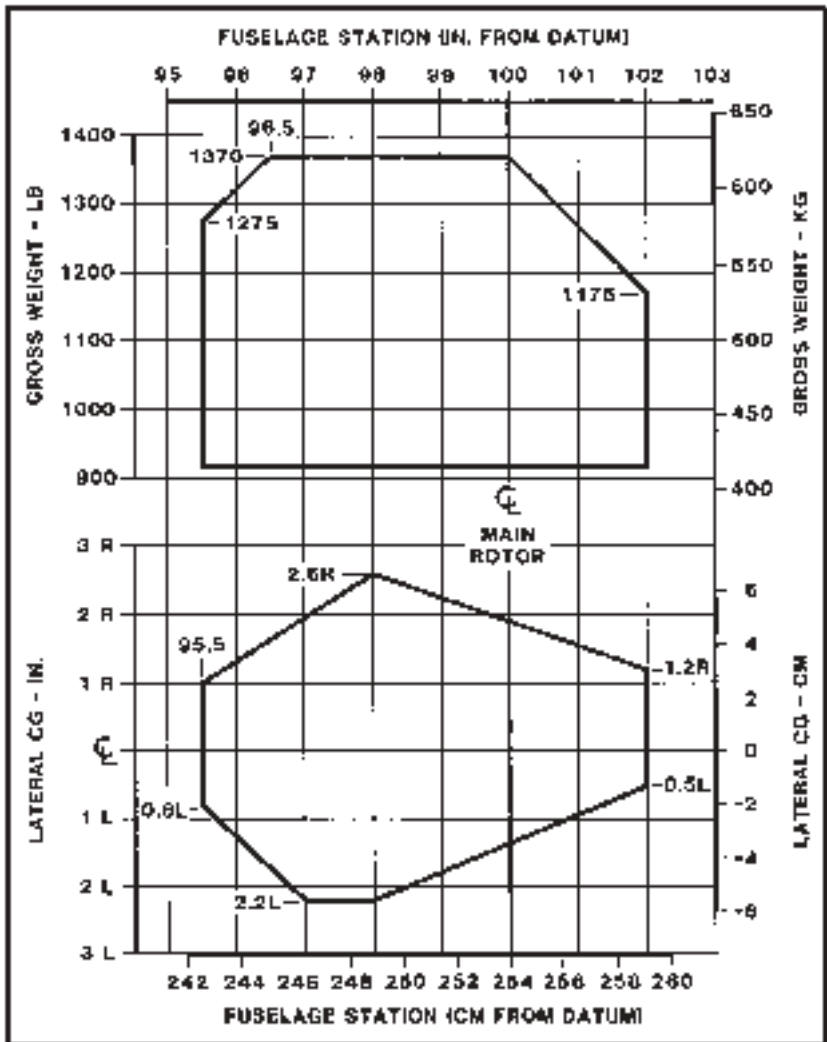

R22 ALPHA, BETA, AND BETA II
CENTER OF GRAVITY LIMITS

FLIGHT AND MANEUVER LIMITATIONS

Aerobatic flight prohibited.

CAUTION

Abrupt control inputs may produce high fatigue stresses and cause catastrophic failure of a critical component.

Low-G cyclic pushovers prohibited.

CAUTION

A pushover (forward cyclic maneuver) performed from level flight or following a pull-up causes a low-G (near weightless) condition which can result in catastrophic loss of lateral control. To eliminate a low-G condition, immediately apply gentle aft cyclic. Should a right roll commence during a low-G condition, apply gentle aft cyclic to reload rotor before applying lateral cyclic to stop the roll.

Flight prohibited with governor selected off, with exceptions for in-flight system malfunction or emergency procedures training.

Flight in known icing conditions prohibited.

Maximum operating density altitude 14,000 feet.

Alternator, RPM governor, low rotor RPM warning system, and OAT gage must be operational for dispatch.

Minimum crew is one pilot in the right seat. A flight instructor may act as pilot in command from the left seat. Solo flight from right seat only.

Left seat belt must be buckled.

Operation approved with either or both cabin doors removed. Loose items in cabin must be properly secured during doors-off flight.

| A functioning headset must be worn by each pilot.

KINDS OF OPERATION LIMITATIONS

VFR day and night operations are approved.

VFR operation at night is permitted only when landing, navigation, instrument, and anti-collision lights are operational. Orientation during night flight must be maintained by visual reference to ground objects illuminated solely by lights on the ground or adequate celestial illumination.

Note: There may be additional requirements in countries outside the United States.

FUEL LIMITATIONS

APPROVED FUEL GRADES

Grade	Color	Specification
100	Green	ASTM D910
100LL	Blue	
100VLL	Blue	
UL 91	Clear to Yellow (no dye)	ASTM D7547
UL 94		
HJELMCO 91/96 UL	Clear to Yellow (no dye)	Hjelmco Oil, Inc. Sollentuna, Sweden
91	Yellow	TU 38.5901481-96 Ukrainian National Standard
B91/115	Green	GOST 1012-72 Russian National Standard
B95/130	Amber	

FUEL LIMITATIONS (cont'd)

FUEL CAPACITY

	Total Capacity US gallons (liters)	Usable Capacity US gallons (liters)
Tanks with bladders:		
Main tank	18.3 (69)	16.9 (64)
Auxiliary tank	9.7 (37)	9.4 (36)
Combined capacity	28.0 (106)	26.3 (100)
Tanks without bladders:		
Main tank	19.8 (75)	19.2 (73)
Auxiliary tank	10.9 (41)	10.5 (40)
Combined capacity	30.7 (116)	29.7 (112)

Note: Per R22 Service Bulletin SB-109A, fuel tanks without bladders should no longer be in service.

INSTRUMENT MARKINGS

AIRSPEED INDICATOR

Green arc	50 to 102 KIAS
Red line	102 KIAS

ROTOR TACHOMETER

Yellow arc	60 to 70%
Lower red line	90 %
Lower Yellow arc	90 to 101% *
Green arc	101 to 104% *
Upper Yellow arc	104 to 110%
Upper red line	110%

ENGINE TACHOMETER

Yellow arc	60 to 70%
Lower red arc	90 to 101% *
Green arc	101 to 104% *
Upper red arc	104 to 110%

*R22s with O-320 engine may have tachometer with green arc from 97% to 104% RPM.

INSTRUMENT MARKINGS (cont'd)

OIL PRESSURE*

Lower red line	25 psi
Lower yellow arc	25 to 55 psi
Green arc	55 to 95 psi
Upper yellow arc	95 to 115 psi
Upper red line	115 psi

*Earlier gages show green arc from 60 to 90 psi and upper red line at 100 psi.

OIL TEMPERATURE

Green arc	75 to 245°F (24 to 118°C)
Red line	245°F (118°C)

CYLINDER HEAD TEMPERATURE

Green arc	200 to 500°F (93 to 260°C)
Red line	500°F (260°C)

MANIFOLD PRESSURE

Yellow arcs denote variable MAP limits.
See placards on pages 2-10 and 2-11.

Standard R22 (O-320-A2B or -A2C Engine)

Yellow arc	23.2 to 25.9 in. Hg
Red line	25.9 in. Hg

HP and Alpha (O-320-B2C Engine)

Yellow arc	21.0 to 24.1 in. Hg
Red line	24.1 in. Hg

Beta (O-320-B2C Engine)

Yellow arc	21.0 to 25.2 in. Hg
Red line	25.2 in. Hg

Beta II (O-360 J2A Engine)

Yellow arc	19.6 to 24.1 in. Hg
Red line	24.1 in. Hg

CARBURETOR AIR TEMPERATURE

Yellow arc	-15 to 5°C
------------	------------

PLACARDS

In clear view and readable by pilot in flight:

Standard R22
O-320-A2B or
A2C Engine

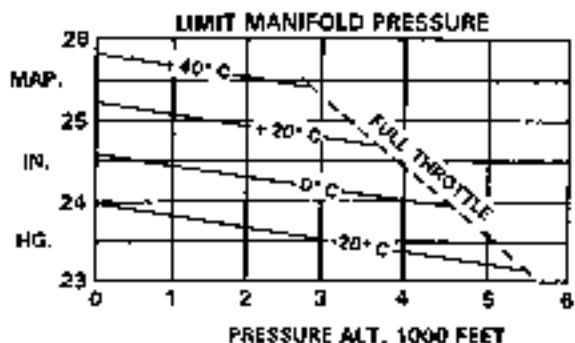

R22 HP and Alpha
O-320-B2C Engine

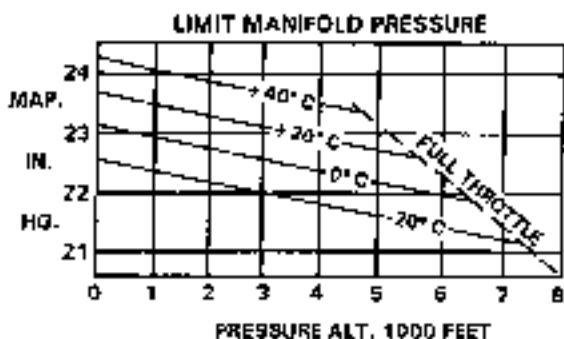

R22 Beta
O-320-B2C Engine

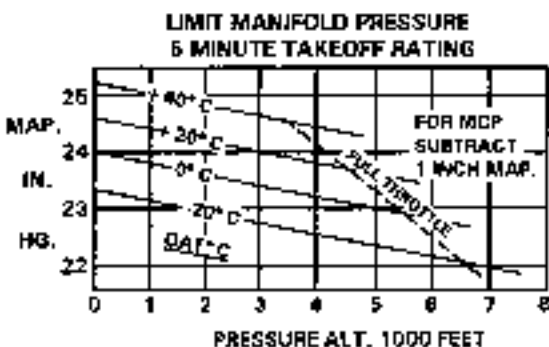

PLACARDS (cont'd)

R22 Beta II
O-360-J2A Engine

LIMIT MANIFOLD PRESSURE - IN. HG
MAXIMUM CONTINUOUS POWER

PRESS	OAT - °C						
ALT-FT	-20	-10	0	10	20	30	40
SL	21.5	21.8	22.1	22.3	22.6	22.9	23.2
2000	21.1	21.4	21.6	21.9	22.2	22.5	22.8
4000	20.7	21.0	21.2	21.5	21.8	22.0	22.3
6000	20.3	20.6	20.8	21.1	21.3	21.6	21.9
8000	19.9	20.2	20.4	20.7	20.9	FULL THROTTLE	
FOR MAX TAKEOFF POWER (5 MIN), ADD 0.9 IN. HG							

All R22s
except Beta II

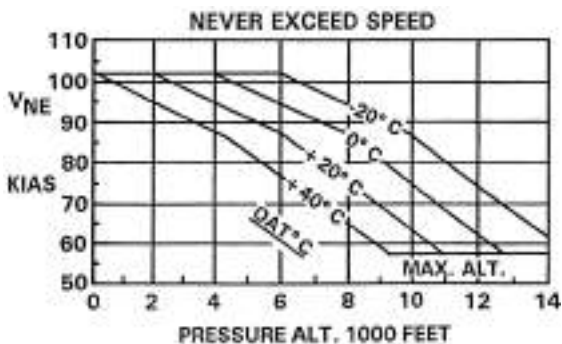

R22 Beta II

NEVER EXCEED SPEED - KIAS

PRESS	OAT - °C						
ALT-FT	-20	-10	0	10	20	30	40
SL							
2000	102					99	95
4000				98	94	91	87
6000		98	94	90	87	82	77
8000	94	90	86	80	75	69	64
10000	86	80	74	68	62	57	
12000	74	67	61				
14000	61						
NO FLIGHT							

PLACARDS (cont'd)

Near main fuel tank filler cap:

FUEL
100 OCT MIN GRADE AVIATION GASOLINE

or

FUEL
91/96 MIN GRADE AVIATION GASOLINE

or

FUEL
AVIATION GASOLINE – GRADE 100LL
OR SEE PILOT'S HANDBOOK

or

R22s with O-320-A2B or -A2C engine may have:

FUEL
80/87 MIN GRADE AVIATION GASOLINE

Near aux fuel tank filler cap:

AUX FUEL
100 OCT MIN GRADE AVIATION GASOLINE

or

AUX FUEL
91/96 MIN GRADE AVIATION GASOLINE

or

AUX FUEL
AVIATION GASOLINE – GRADE 100LL
OR SEE PILOT'S HANDBOOK

PLACARDS (cont'd)

Near shut-off valve:

FUEL
ON OFF

Near main tank fuel gage:

For bladder-style tank

16.9 US GAL

For aluminum (non-bladder) tank

19.2 US GAL

Near aux tank fuel gage:

For bladder-style tank

AUX 9.4 US GAL

For aluminum (non-bladder) tank

AUX 10.5 US GAL

In clear view of both occupants:

NO SMOKING

In clear view of pilot (Alpha, Beta, and Beta II with aft battery installations):

MINIMUM SOLO PILOT WEIGHT 130 LB
(135 LB WITH FULL AUX FUEL)

or

SEE PILOT'S HANDBOOK FOR SOLO PILOT
WEIGHT LESS THAN 135 LB (61KG)

PLACARDS (cont'd)

In clear view of pilot:

THIS ROTORCRAFT APPROVED FOR
DAY AND NIGHT VFR OPERATIONS

LOW-G PUSHOVERS PROHIBITED

On left-hand cyclic:

SOLO FROM RIGHT SEAT ONLY

On or near collective controls:

NO STOWAGE
KEEP AREA CLEAR

Inside each baggage compartment:

CAUTION

DO NOT EXCEED ANY OF THE FOLLOWING:

- COMPARTMENT CAPACITY: 50 LB MAX
 - COMBINED SEAT PLUS COMPARTMENT: 240 LB MAX
 - ROTORCRAFT GROSS WEIGHT LIMIT
- SEE ROTORCRAFT FLIGHT MANUAL FOR ADDITIONAL INSTRUCTIONS

On carburetor air temperature gage:

CAUTION

BELOW 18 IN. MP, IGNORE GAGE
& APPLY FULL CARB HEAT

Near heater push-pull control when heater is installed:

IN CASE OF ENGINE FIRE
PUSH HEATER CONTROL TO OFF

INFORMATION PER FAA AD 95-26-04

The following limitations (1-3) are to be observed unless the pilot manipulating the controls has logged 200 or more flight hours in helicopters, at least 50 of which must be in the RHC Model R22 helicopter, and has completed the awareness training specified in Special Federal Aviation Regulation (SFAR) No. 73, issued February 27, 1995.

1. Flight when surface winds exceed 25 knots, including gusts, is prohibited.
2. Flight when surface wind gust spreads exceed 15 knots is prohibited.
3. Continued flight in moderate, severe, or extreme turbulence is prohibited.

Adjust forward airspeed to between 60 knots indicated airspeed (KIAS) and $0.7 V_{ne}$ but no lower than 57 KIAS, upon inadvertently encountering moderate, severe, or extreme turbulence.

Note: Moderate turbulence is turbulence that causes: (1) changes in altitude or attitude; (2) variations in indicated airspeed; and (3) aircraft occupants to feel definite strains against seat belts.

RHC NOTE

This AD is issued by the FAA and is applicable to US-registered helicopters.

INTENTIONALLY BLANK

SECTION 3

EMERGENCY PROCEDURES

CONTENTS

	Page
Definitions	3-1
Power Failure - General	3-1
Power Failure Above 500 Feet AGL	3-2
Power Failure Between 8 Feet and 500 Feet AGL	3-2
Power Failure Below 8 Feet AGL	3-3
Maximum Glide Distance Configuration	3-3
Air Restart Procedure	3-3
Emergency Water Landing - Power Off	3-4
Emergency Water Landing - Power On	3-4
Loss of Tail Rotor Thrust in Forward Flight	3-5
Loss of Tail Rotor Thrust in Hover	3-5
Headset Audio Failure	3-5
Engine Fire During Start on Ground	3-6
Engine Fire in Flight	3-6
Electrical Fire in Flight	3-6
Tachometer Failure	3-7
Governor Failure	3-7
Warning/Caution Lights	3-8
Audio Alerts	3-10
Information per FAA AD 95-26-04	3-11

INTENTIONALLY BLANK

SECTION 3

EMERGENCY PROCEDURES

DEFINITIONS

Land Immediately - Land on the nearest clear area where a safe normal landing can be performed. Be prepared to enter autorotation during approach, if required.

Land as soon as practical - Landing site is at pilot's discretion based on nature of problem and available landing areas. Flight beyond nearest airport is not recommended.

POWER FAILURE - GENERAL

A power failure may be caused by either an engine or drive system failure and will usually be indicated by the low RPM horn. An engine failure may be indicated by a change in noise level, nose left yaw, an oil pressure light, or decreasing engine RPM. A drive system failure may be indicated by an unusual noise or vibration, nose right or left yaw, or decreasing rotor RPM while engine RPM is increasing.

In case of power failure, immediately lower collective to enter autorotation.

CAUTION

Aft cyclic is required when collective is lowered at high airspeed.

CAUTION

Do not apply aft cyclic during touchdown or ground slide to prevent possible blade strike to tailcone.

POWER FAILURE ABOVE 500 FEET AGL

1. Lower collective immediately to maintain rotor RPM.
2. Establish a steady glide at approximately 65 KIAS. (For maximum glide distance, see page 3-3.)
3. Adjust collective to keep RPM between 97 and 110% or apply full down collective if light weight prevents attaining above 97%.
4. Select landing spot and, if altitude permits, maneuver so landing will be into wind.
5. A restart may be attempted at pilot's discretion if sufficient time is available (See "Air Restart Procedure", page 3-3).
6. If unable to restart, turn unnecessary switches and fuel valve off.
7. At about 40 feet AGL, begin cyclic flare to reduce rate of descent and forward speed.
8. At about 8 feet AGL, apply forward cyclic to level ship and raise collective just before touchdown to cushion landing. Touch down in level attitude with nose straight ahead.

POWER FAILURE BETWEEN 8 FEET AND 500 FEET AGL

1. Lower collective immediately to maintain rotor RPM.
2. Adjust collective to keep RPM between 97 and 110% or apply full down collective if light weight prevents attaining above 97%.
3. Maintain airspeed until ground is approached, then begin cyclic flare to reduce rate of descent and forward speed.
4. At about 8 feet AGL, apply forward cyclic to level ship and raise collective just before touchdown to cushion landing. Touch down in level attitude and nose straight ahead.

POWER FAILURE BELOW 8 FEET AGL

1. Apply right pedal as required to prevent yawing.
2. Allow aircraft to settle.
3. Raise collective just before touchdown to cushion landing.

MAXIMUM GLIDE DISTANCE CONFIGURATION

1. Airspeed approximately 75 KIAS.
2. Rotor RPM approximately 90%.
3. Best glide ratio is about 4:1 or one nautical mile per 1500 feet AGL.

CAUTION

Increase rotor RPM to 97% minimum when autorotating below 500 feet AGL.

AIR RESTART PROCEDURE

1. Mixture - full rich.
2. Primer (if installed) - down and locked.
3. Throttle - closed, then cracked slightly.
4. Actuate starter with left hand.

CAUTION

Do not attempt restart if engine malfunction is suspected or before safe autorotation is established.

EMERGENCY WATER LANDING – POWER OFF

1. Follow same procedures as for power failure over land until contacting water. If time permits, unlatch doors prior to water contact.
2. Apply lateral cyclic when aircraft contacts water to stop rotors.
3. Release seat belt and quickly clear aircraft when rotors stop.

EMERGENCY WATER LANDING – POWER ON

1. Descend to hover above water.
2. Unlatch doors.
3. Passenger exit aircraft.
4. Fly to safe distance from passenger to avoid possible injury by rotors.
5. Switch battery and alternator OFF.
6. Roll throttle off into overtravel spring.
7. Keep aircraft level and apply full collective as aircraft contacts water.
8. Apply lateral cyclic to stop rotors.
9. Release seat belt and quickly clear aircraft when rotors stop.

LOSS OF TAIL ROTOR THRUST IN FORWARD FLIGHT

Failure is usually indicated by nose right yaw which cannot be corrected by applying left pedal.

1. Immediately enter autorotation.
2. Maintain at least 70 KIAS if practical.
3. Select landing site, roll throttle off into overtravel spring, and perform autorotation landing.

NOTE

When a suitable landing site is not available, the vertical stabilizers may permit limited controlled flight at low power settings and airspeeds above 70 KIAS; however, prior to reducing airspeed, enter full autorotation.

LOSS OF TAIL ROTOR THRUST IN HOVER

Failure is usually indicated by nose right yaw which cannot be stopped by applying left pedal.

1. Immediately roll throttle off into overtravel spring and allow aircraft to settle.
2. Raise collective just before touchdown to cushion landing.

HEADSET AUDIO FAILURE

If headset audio fails, land as soon as practical.

CAUTION

For aircraft which provide low RPM horn through the audio system, pilot will not hear horn with a failed headset.

ENGINE FIRE DURING START ON GROUND

1. Cranking – Continue and attempt to start which would suck flames and excess fuel into engine.
2. If engine starts, run at 50-60% RPM for a short time.
3. Fuel mixture – OFF.
4. Fuel valve – OFF.
5. Battery switch – OFF.
6. If time permits, apply rotor brake to stop rotors.
7. Exit helicopter.

ENGINE FIRE IN FLIGHT

1. Enter autorotation.
2. Cabin heat – OFF (if installed and time permits).
3. Cabin vent – ON (if time permits).
4. **If engine is running**, perform normal landing, then fuel mixture OFF and fuel valve OFF.
If engine stops running, fuel valve OFF and complete autorotation landing.
5. Battery switch – OFF.
6. If time permits, apply rotor brake to stop rotors.
7. Exit helicopter.

ELECTRICAL FIRE IN FLIGHT

1. Battery and alternator switches – OFF.
2. Open cabin vents.
3. Land immediately.
4. Fuel mixture OFF and fuel valve OFF.
5. If time permits, apply rotor brake to stop rotors.
6. Exit helicopter.

CAUTION

Low RPM warning system and governor are inoperative with battery and alternator switches both off.

TACHOMETER FAILURE

If rotor or engine tach malfunctions in flight, use remaining tach to monitor RPM. If it is not clear which tach is malfunctioning or if both tachs malfunction, allow governor to control RPM and land as soon as practical.

NOTE

Each tach, the governor, and the low RPM horn are on separate power circuits. A special circuit allows the battery to supply power to the tachs with the battery and alternator switches both off.

GOVERNOR FAILURE

If engine RPM governor malfunctions, grip throttle firmly to override the governor, then switch governor off. Complete flight using manual throttle control.

WARNING/CAUTION LIGHTS

NOTE

If a light causes excessive glare at night, bulb may be unscrewed or circuit breaker pulled to eliminate glare during landing.

- OIL** Indicates loss of engine power or oil pressure. Check engine tach for power loss. Check oil pressure gage and, if pressure loss is confirmed, land immediately. Continued operation without oil pressure will cause serious engine damage and engine failure may occur.
- MR TEMP** Indicates excessive temperature of main rotor gearbox. See note below.
- MR CHIP** Indicates metallic particles in main rotor gearbox. See note below.
- TR CHIP** Indicates metallic particles in tail rotor gearbox. See note below.

NOTE

If light is accompanied by any indication of a problem such as noise, vibration, or temperature rise, land immediately. If there is no other indication of a problem, land as soon as practical.

Break-in fuzz will occasionally activate chip lights. If no metal chips or slivers are found on detector plug, clean and reinstall (tail rotor gearbox must be refilled with new oil). Hover for at least 30 minutes. If chip light comes on again, replace gearbox before further flight.

WARNING/CAUTION LIGHTS (cont'd)

LOW FUEL Indicates approximately one gallon of usable fuel remaining for all-aluminum fuel tanks or 1.5 gallons for bladder-style tanks. The engine will run out of fuel after approximately five minutes at cruise power for aircraft with all-aluminum tanks or ten minutes with bladder-style tanks.

CAUTION

Do not use low fuel caution light as a working indication of fuel quantity.

CLUTCH Indicates clutch actuator circuit is on, either engaging or disengaging clutch. When switch is in the ENGAGE position, light stays on until belts are properly tensioned. Never take off before light goes out.

NOTE

Clutch light may come on momentarily during run-up or during flight to retension belts as they warm-up and stretch slightly. This is normal. If, however, the light flickers or comes on in flight and does not go out within 10 seconds, pull CLUTCH circuit breaker and land as soon as practical. Reduce power and land immediately if there are other indications of drive system failure (be prepared to enter autorotation). Have drive system inspected for a possible malfunction.

ALT Indicates low voltage and possible alternator failure. Turn off nonessential electrical equipment and switch ALT off and back on after one second to reset alternator control unit. If light stays on, land as soon as practical. Continued flight without functioning alternator can result in loss of power to tachometers, producing a hazardous flight condition.

WARNING/CAUTION LIGHTS (cont'd)

STARTER ON Indicates starter motor is engaged. If light does not go out when ignition switch is released from start position, immediately pull mixture off and turn battery switch off. Have starter motor serviced.

LOW RPM Indicates rotor speed below 97% RPM. To restore RPM, immediately lower collective, roll throttle on and, in forward flight, apply aft cyclic. Light is disabled when collective is full down.

GOV OFF Indicates engine RPM governor is switched off.

CARBON MONOXIDE (if installed) Indicates elevated levels of carbon monoxide (CO) in cabin. Shut off heater and open nose and door vents. If hovering, land or transition to forward flight. If symptoms of CO poisoning (headache, drowsiness, dizziness) accompany light, land immediately.

BRAKE Indicates rotor brake is engaged. Release immediately in flight or before starting engine.

FULL THROTTLE (if installed) Indicates engine near full throttle. The governor will be ineffective because it cannot increase throttle to maintain RPM. Lower collective as required to extinguish light.

AUDIO ALERTS

LOW RPM HORN

Horn is provided by a speaker in the side of the instrument console on earlier aircraft or through the audio system on later aircraft. The horn activates simultaneously with the LOW RPM caution light and indicates rotor speed below 97% RPM. To restore RPM, lower collective, roll throttle on and, in forward flight, apply aft cyclic. Horn and Light are disabled when collective is full down.

AUDIO ALERTS (Cont'd)

HIGH RPM WARBLE

On later aircraft, a warble (high/low tone) in the audio system indicates rotor speed is approaching 110% RPM limit. Raise collective as required to control RPM.

INFORMATION PER FAA AD 95-26-04

1) RIGHT ROLL IN LOW "G" CONDITION

Gradually apply aft cyclic to restore positive "G" forces and main rotor thrust. Do not apply lateral cyclic until positive "G" forces have been established.

2) UNCOMMANDED PITCH, ROLL, OR YAW RESULTING FROM FLIGHT IN TURBULENCE.

Gradually apply controls to maintain rotor RPM, positive "G" forces, and to eliminate sideslip. Minimize cyclic control inputs in turbulence; do not overcontrol.

3) INADVERTENT ENCOUNTER WITH MODERATE, SEVERE, OR EXTREME TURBULENCE.

If the area of turbulence is isolated, depart the area; otherwise, land the helicopter as soon as practical.

INTENTIONALLY BLANK

SECTION 4

NORMAL PROCEDURES

CONTENTS

	Page
Recommended Airspeeds	4-1
Daily or Preflight Checks	4-1
Before Starting Engine	4-6
Starting Engine and Run-Up	4-7
Takeoff Procedure	4-8
Cruise	4-8
Doors-Off Operation	4-9
Practice Autorotation – Power Recovery	4-9
Practice Autorotation – With Ground Contact	4-10
Use of Carburetor Heat	4-11
Use of Carb Heat Assist	4-11
Descent, Approach, and Landing	4-12
Shutdown Procedure	4-13
Noise Abatement	4-14
Information per FAA AD 95-26-04	4-15

INTENTIONALLY BLANK

SECTION 4

NORMAL PROCEDURES

RECOMMENDED AIRSPEEDS

Takeoff and Climb	60 KIAS
Maximum Rate of Climb (V_y)	53 KIAS
Maximum Range	83 KIAS*
Significant Turbulence	60 to 70 KIAS*
Landing Approach	60 KIAS
Autorotation	60 to 70 KIAS*

* Certain conditions may require lower airspeed.
See V_{ne} placards in Section 2.

DAILY OR PREFLIGHT CHECKS

Remove ground handling wheels and all covers and tiedowns. Remove even small accumulations of frost, ice, or snow, especially from rotor blades. Check maintenance records to verify aircraft is airworthy.

Check general condition of aircraft and verify no visible damage, fluid leakage, or abnormal wear. Verify no fretting at rivets and seams where parts are joined together. Fretting of aluminum parts produces a fine black powder while fretting of steel parts produces a reddish-brown or black residue. Verify Telatemps show no temperature increase that cannot be attributed to a change in operating conditions (mechanics draw a reference line to the right of the highest temperature square which has darkened in operation). Verify torque stripes on critical fasteners are not broken or missing.

DAILY OR PREFLIGHT CHECKS (cont'd)

1. Cowl Doors

Battery switch	ON
Oil pressure and alternator lights	ON
Warning light test switches	Push to test
Fuel quantity	Check gages
Battery switch	OFF
Aux fuel tank quantity	Check
Fuel filler cap	Tight
Aux fuel tank	No leaks
Fuel lines	No leaks
Fuel tank sump drain(s)	Sample
Gearbox oil	Full, no leaks
Rotor brake	Actuation normal
Flex coupling	No cracks, nuts secure
Yoke flanges	No cracks
Gearbox Telatemp	Normal
Sprag clutch	No leaks
Static source	Clear
Control rod ends	Free without looseness
Steel tube frame	No cracks
All fasteners	Secure
Tail rotor control	No interference
Cowl doors	Latched

2. Engine Right Side

Carb air ducts	Secure
Carb heat scoop	Secure
Engine sheet metal	No cracks
Electrical terminals	Tight
Fuel line	No leaks
Oil cooler door	Check
Oil lines	No leaks or chafing
Exhaust system	No cracks
Engine general condition	Check
V-belt condition	Check
V-belt slack	Check
Sprag clutch	No leaks
Upper bearing	No leaks
Telatemp – upper bearing	Normal

DAILY OR PREFLIGHT CHECKS (cont'd)

2. Engine Right Side (cont'd)

- Upper Sheave Condition Check
- Lower sheave groove wear Smooth & Uniform
- Flex coupling No cracks, nuts secure
- Yoke flanges No cracks
- Steel tube frame No cracks
- Tail rotor control No interference

3. Engine Rear

- Cooling fan nut Pin in line with marks
- Cooling fan No cracks
- Fan scroll No cracks
- Teletemps – lower bearing Normal
- Lower bearing No leaks

4. Empennage

- Tail surfaces No cracks
- Fasteners Secure
- Position light Check

5. Tail Rotor

- Gearbox Telatemp Normal
- Gearbox Oil visible, no leaks
- Blades Clean and no damage/cracks
- Pitch links No looseness
- Teeter bearings Check condition
- Teeter bearing bolt Does not rotate
- Control bellcrank Free without looseness

6. Tailcone

- Skins No cracks or dents
- Strobe light condition Check
- Antenna Check

DAILY OR PREFLIGHT CHECKS (cont'd)

7. Engine Left Side

- Engine oil 4-6 qt
- Oil filter (if installed) Secure, no leaks
- Fuel lines No leaks
- Gascolator drain Sample
- Throttle linkage Operable
- Battery and relay (if located here) Secure
- Alternator belt tension Check
- Steel tube frame No cracks
- Engine sheet metal No cracks
- Exhaust system No cracks
- Engine general condition Check

8. Main Fuel Tank

- Quantity Check
- Filler cap Tight
- Leakage None

9. Main Rotor

CAUTION

Do not pull down on blades to teeter rotor. To lower a blade, push up on opposite blade.

- Blades Clean and no damage/cracks

CAUTION

Verify erosion on lower surface of blades has not exposed skin-to-spar bond line. Reference Rotor Systems description in Section 7.

- Pitch change boots No leaks
- Main hinge bolts Cotter pins installed
- All rod ends Free without looseness
- All fasteners Secure
- Swashplate scissors No excessive looseness

DAILY OR PREFLIGHT CHECKS (cont'd)

10. Fuselage Left Side

- Baggage compartment Check
- Removable controls Secure if installed
- Collective control Clear
- Seat Belt Check condition and fastened
- Door Unlocked and latched
- Door hinge safety pins Installed
- Landing gear Check
- Position light Check

11. Nose Section

- Pitot tube Clear
- Windshield condition and cleanliness Check
- Landing lights Check
- Yaw string Check

12. Fuselage Right Side

- Landing gear Check
- Position light Check
- Door hinge safety pins Installed
- Baggage compartment Check

13. Cabin Interior

- Loose articles Removed or stowed
- Seat belt Check condition
- Instruments, switches, and controls Check condition
- Clock Functioning

CAUTION

For helicopters with removable controls, remove left seat controls if person in that seat is not a rated helicopter pilot.

CAUTION

Be sure rotor blades are approximately level to avoid possible tailcone strike.

DAILY OR PREFLIGHT CHECKS (cont'd)

CAUTION

When flying solo, fill left baggage compartment to capacity before using right compartment. Avoid placing objects in compartments which could injure occupant if seat collapses during a hard landing.

CAUTION

Shorter pilots may require cushion to obtain full travel of all controls. Verify aft cyclic travel is not restricted.

BEFORE STARTING ENGINE

- Seat belts Fastened
- Fuel shut-off valve ON
- Cyclic/collective friction OFF
- Cyclic, collective, pedals Full travel free
- Throttle Full travel free
- Collective Full down, friction ON
- Cyclic Neutral, friction ON
- Pedals Neutral
- Rotor brake Disengaged
- Circuit breakers In
- Carb heat OFF
- Mixture Full rich
- Mixture guard* Installed
- Primer (if installed) Down and locked
- Landing lights OFF
- Avionics switch (if installed) OFF
- Clutch Disengaged
- Altimeter Set
- Governor switch ON

* Mixture guard is not used on aircraft with vernier mixture control on console face.

STARTING ENGINE AND RUN-UP

Throttle twists for priming As required
Throttle Closed
Battery, strobe switches ON
Area Clear
Ignition switch Start, then Both
Starter-On light Out
Set engine RPM 50 to 60%
Clutch switch Engaged
Blades turning Less than 5 seconds
Alternator switch ON
Oil pressure within 30 seconds 25 psi minimum
Avionics, headsets ON
Audio alert (if equipped) Test
Wait for clutch light out Circuit breakers in
Warm-up RPM 70 to 75%
Engine gages Green
Mag drop at 75% RPM 7% max in 2 seconds
Carb heat CAT rise/drop, set as required
Sprag clutch check Needles split
Doors (if installed) Closed and latched
Limit MAP chart Check
Cyclic/collective friction OFF
Governor On, increase throttle RPM 102-104%
Warning lights Out
Lift collective slightly, reduce RPM Horn/light at 97%

CAUTION

For aircraft which provide low RPM horn through the audio system, a headset for each pilot is required to hear the horn.

CAUTION

Avoid continuous operation at rotor speed of 60 to 70% to minimize tail resonance.

CAUTION

On slippery surfaces, be prepared to counter nose-right rotation with left pedal as governor increases RPM.

TAKEOFF PROCEDURE

1. Verify doors latched, governor ON, and RPM stabilized at 102 to 104%.
2. Clear area. Slowly raise collective until aircraft is light on skids. Reposition cyclic as required for equilibrium, then gently lift aircraft into hover.
3. Check gages in green and adjust carb heat if required.
4. Lower nose and accelerate to climb speed following profile shown by height-velocity diagram in Section 5. If RPM drops below 102%, lower collective.

CRUISE

1. Adjust carb heat if required. (See page 4-11.)
2. Verify RPM near top of green arc.
3. Set manifold pressure as desired with collective. Observe MAP and airspeed limits.
4. Pull RT TRIM knob.
5. Verify gages in green, warning lights out.

CAUTION

In turbulence, reduce power and use a slower than normal cruise speed. If turbulence is significant or becomes uncomfortable for the pilot, use 60 to 70 KIAS.

CAUTION

Exercise extreme care never to inadvertently pull mixture control as engine stoppage will result.

CAUTION

In-flight leaning with engine mixture control is not recommended. Engine stoppage may result as there is no propeller to keep engine turning should overleaning occur.

DOORS-OFF OPERATION

Avoid removing left door to protect tail rotor from loose objects. If left door must be removed, warn passenger to secure loose objects and to keep head and arms inside cabin to avoid high velocity airstream.

PRACTICE AUTOROTATION – POWER RECOVERY

1. Adjust carb heat if required. (See page 4-11.)
2. Lower collective to down stop and reduce throttle as desired for tachometer needle separation.

CAUTION

To avoid inadvertent engine stoppage, do not chop throttle to simulate a power failure. Always roll throttle off smoothly. Recover immediately if engine is rough or engine RPM continues to drop.

NOTE

Governor is inactive below 80% engine RPM regardless of governor switch position.

NOTE

When entering autorotation from above 4000 feet, reduce throttle slightly before lowering collective to prevent engine overspeed.

3. Adjust collective to keep rotor RPM within limits and adjust throttle for tachometer needle separation.
4. Keep airspeed 60 to 70 KIAS.
5. At about 40 feet AGL, begin cyclic flare to reduce rate of descent and forward speed.
6. At about 8 feet AGL, apply forward cyclic to level aircraft and raise collective to control descent. Add throttle if required to keep RPM in green arc.

PRACTICE AUTOROTATION - POWER RECOVERY (Cont'd)

CAUTION

Simulated engine failures require prompt lowering of collective to avoid dangerously low rotor RPM. Catastrophic rotor stall could occur if the rotor RPM ever drops below 80% plus 1% per 1000 feet of altitude.

PRACTICE AUTOROTATION - WITH GROUND CONTACT

If practice autorotations with ground contact are required for demonstration purposes, perform in same manner as power recovery autorotations except:

Prior to cyclic flare, roll throttle off into overtravel spring and hold it against hard stop until autorotation is complete. (This prevents throttle correlator from adding power when collective is raised.)

Always contact ground with skids level and nose straight ahead.

CAUTION

The R22 has a light, low-inertia rotor system. Most of the energy required for an autorotation is stored in the forward momentum of the aircraft, not in the rotor. Therefore, a well-timed cyclic flare is required and rotor RPM must be kept in the green until just before ground contact.

NOTE

Have landing gear skid shoes inspected frequently when practicing autorotations with ground contact. Rapid wear of skid shoes may occur.

USE OF CARBURETOR HEAT

Carburetor ice can form in a wide range of atmospheric conditions, but is most likely to form when OAT is between -4°C and 30°C (25°F and 86°F) and the difference between OAT and dew point is less than 15C° (27F°). When conditions conducive to carburetor ice are suspected, use carburetor heat as follows:

During Run-up: Use full carburetor heat (it is filtered) during warm-up to preheat induction system.

During Takeoff, Climb, and Cruise: Use carb heat as required to keep CAT gage indication out of yellow arc.

During Descent and Autorotation: At power settings below 18 inches MAP, apply full carb heat regardless of CAT gage indication. CAT gage does not indicate correct carburetor temperature below 18 inches MAP.

CAUTION

The pilot may be unaware of carburetor ice formation as the governor will automatically increase throttle and maintain constant manifold pressure and RPM. Therefore, the pilot must apply carburetor heat as required whenever icing conditions are suspected.

USE OF CARB HEAT ASSIST

A carburetor heat assist device is installed on R22s with O-360 engines. The carb heat assist correlates application of carburetor heat with changes in collective setting to reduce pilot work load. Lowering collective mechanically adds heat and raising collective reduces heat. A friction clutch allows the pilot to override the system and increase or decrease heat as required.

A latch is provided at the control knob to lock carburetor heat off. The knob should be left unlatched unless it is obvious that conditions are not conducive to carburetor ice. Apply carburetor heat as required if carburetor ice is a possibility. Monitor CAT gage and readjust as necessary following lift to hover or any power change.

DESCENT, APPROACH, AND LANDING

1. Reduce power with collective as desired. Adjust carb heat as required. Observe airspeed limits.

CAUTION

Do not initiate a descent with forward cyclic. This can produce a low-G condition. Always initiate a descent by lowering collective.

2. Make final approach into wind at lowest practical rate of descent with initial airspeed of 60 knots.
3. Reduce airspeed and altitude smoothly to hover. (Be sure rate of descent is less than 300 FPM before airspeed is reduced below 30 KIAS.)
4. From hover, lower collective gradually until ground contact.
5. After initial ground contact, lower collective to full down position.

CAUTION

When landing on a slope, return cyclic control to neutral before reducing rotor RPM.

CAUTION

Never leave helicopter flight controls unattended while engine is running.

CAUTION

Hold throttle closed if passenger is entering or exiting with engine running and left seat collective installed.

SHUTDOWN PROCEDURE

Collective down, RPM 70-75% Friction ON
Cyclic and pedals neutral Friction ON
CHT drop Throttle closed
Clutch switch Disengage
Wait 30 seconds Mixture OFF
Mixture guard Back on mixture
Wait 30 seconds Apply rotor brake
Clutch light Extinguishes
Avionics, alt, battery, and ignition switches OFF

NOTE

If ambient temperature is above 100°F (38°C), cool down at 70-75% RPM for at least one minute before reducing to idle.

NOTE

During idle and after engine shutdown, pilot should uncover one ear and listen for unusual noise which may indicate impending failure of a bearing or other component.

CAUTION

Do not slow rotor by raising collective during shutdown. Blades may flap and strike tailcone.

NOISE ABATEMENT

To improve the quality of our environment and to dissuade overly restrictive ordinances against helicopters, it is imperative that every pilot minimize noise irritation to the public. Following are several techniques which should be employed when possible.

1. Avoid flying over outdoor assemblies of people. When this cannot be avoided, fly as high as practical, preferably over 2000 feet AGL.
2. Avoid blade slap. Blade slap usually occurs during shallow high-speed descents, especially during turns. It can be avoided by using slower, steeper descents. With the right door removed, the pilot can easily determine those flight conditions which produce blade slap and develop piloting techniques to eliminate or reduce it.
3. When departing from or approaching a landing site, avoid prolonged flight over noise-sensitive areas. Always fly above 500 feet AGL and preferably above 1000 feet AGL.
4. Repetitive noise is far more irritating than a single occurrence. If you must fly over the same area more than once, vary your flight path to not overfly the same buildings each time.
5. When overflying populated areas, look ahead and select the least noise-sensitive route.

NOTE

Above procedures do not apply where they would conflict with Air Traffic Control clearances or instructions or when, in the pilot's judgment, they would result in an unsafe flight path.

INFORMATION PER FAA AD 95-26-04

Until the FAA completes its research into the conditions and aircraft characteristics that lead to main rotor blade/fuselage contact accidents, and corrective type design changes and operating limitations are identified, Model R22 pilots are strongly urged to become familiar with the following information and comply with these recommended procedures:

Main Rotor Stall Many factors may contribute to main rotor stall and pilots should be familiar with them. Any flight condition that creates excessive angle of attack on the main rotor blades can produce a stall. Low main rotor RPM, aggressive maneuvering, high collective angle (often the result of high density altitude, over-pitching [exceeding power available] during climb, or high forward airspeed), and slow response to the low main rotor RPM warning horn and light may result in main rotor stall. The effect of these conditions can be amplified in turbulence. Main rotor stall can ultimately result in contact between the main rotor and airframe. Additional information on main rotor stall is provided in the Robinson Helicopter Company Safety Notices SN-10, SN-15, SN-20, SN-24, SN-27, and SN-29.

Mast Bumping: Mast bumping may occur with a teetering rotor system when excessive main rotor flapping results from low "G" (load factor below 1.0) or abrupt control input. A low "G" flight condition can result from an abrupt cyclic pushover in forward flight. High forward airspeed, turbulence, and excessive sideslip can accentuate the adverse effects of these control movements. The excessive flapping results in the main rotor hub assembly striking the main rotor mast with subsequent main rotor system separation from the helicopter.

To avoid these conditions, pilots are strongly urged to follow these recommendations:

- 1) Maintain cruise airspeeds between 60 KIAS and less than $0.9 V_{VF}$, but no lower than 57 KIAS.
- 2) Use maximum "power-on" RPM at all times during powered flight.
- 3) Avoid sideslip during flight. Maintain in-trim flight at all times.
- 4) Avoid large, rapid forward cyclic inputs in forward flight, and abrupt control inputs in turbulence.

INTENTIONALLY BLANK

SECTION 5
PERFORMANCE
CONTENTS

	Page
General	5-1
Demonstrated Operating Temperature	5-1
Airspeed Calibration	5-2
Density Altitude Chart	5-3
IGE Hover Ceiling Vs Gross Weight	
R22 Standard	5-4
R22 HP, Alpha, and Beta	5-5
R22 Beta II	5-6
OGE Hover Ceiling Vs Gross Weight	
R22 Standard	5-7
R22 HP and Alpha	5-8
R22 Beta	5-9
R22 Beta II	5-10
Height-Velocity Diagram	5-11

INTENTIONALLY BLANK

SECTION 5
PERFORMANCE

GENERAL

The information contained in Section 5 is approved by the Federal Aviation Administration.

Hover controllability has been substantiated in 17 knot wind from any direction up to 9,800 feet density altitude. Refer to IGE hover performance data for allowable gross weight. Indicated airspeed (KIAS) shown on graphs assumes zero instrument error.

CAUTION

The performance data presented in this section was obtained under ideal conditions. Performance under other conditions may be substantially less.

NOTE

Hover performance data given is with carburetor heat off. Full carburetor heat reduces hover ceilings by up to 2000 feet.

DEMONSTRATED OPERATING TEMPERATURE

Satisfactory engine cooling has been demonstrated to an outside air temperature of 38°C (100°F) at sea level or 23°C (41°F) above ISA at altitude.

Note: Indicated airspeed assumes zero instrument error.

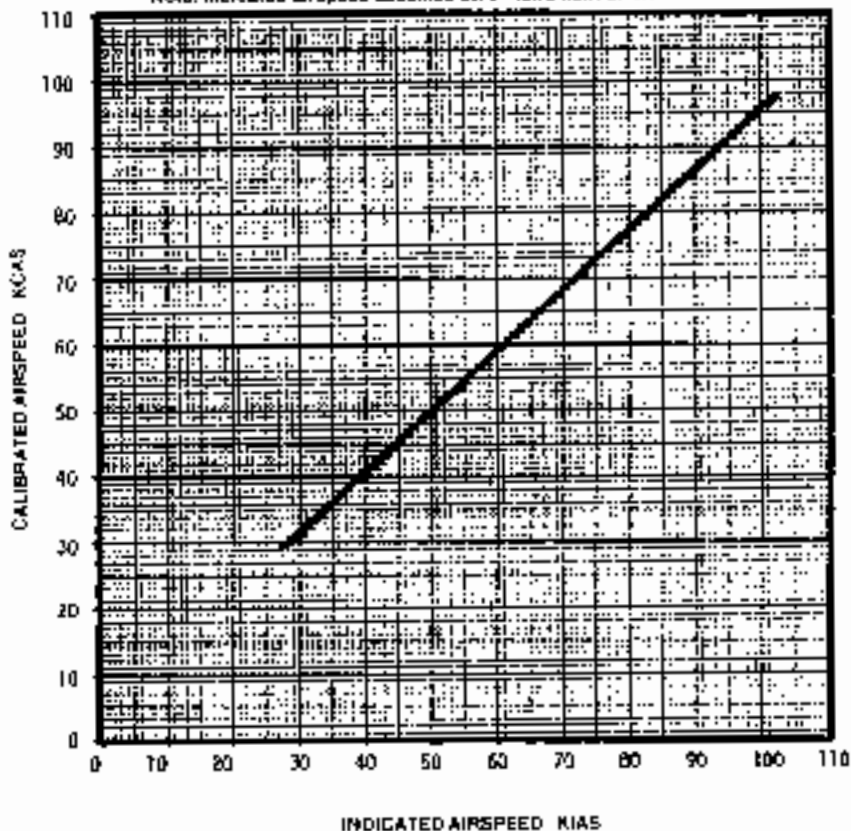

AIRSPEED CALIBRATION CURVE

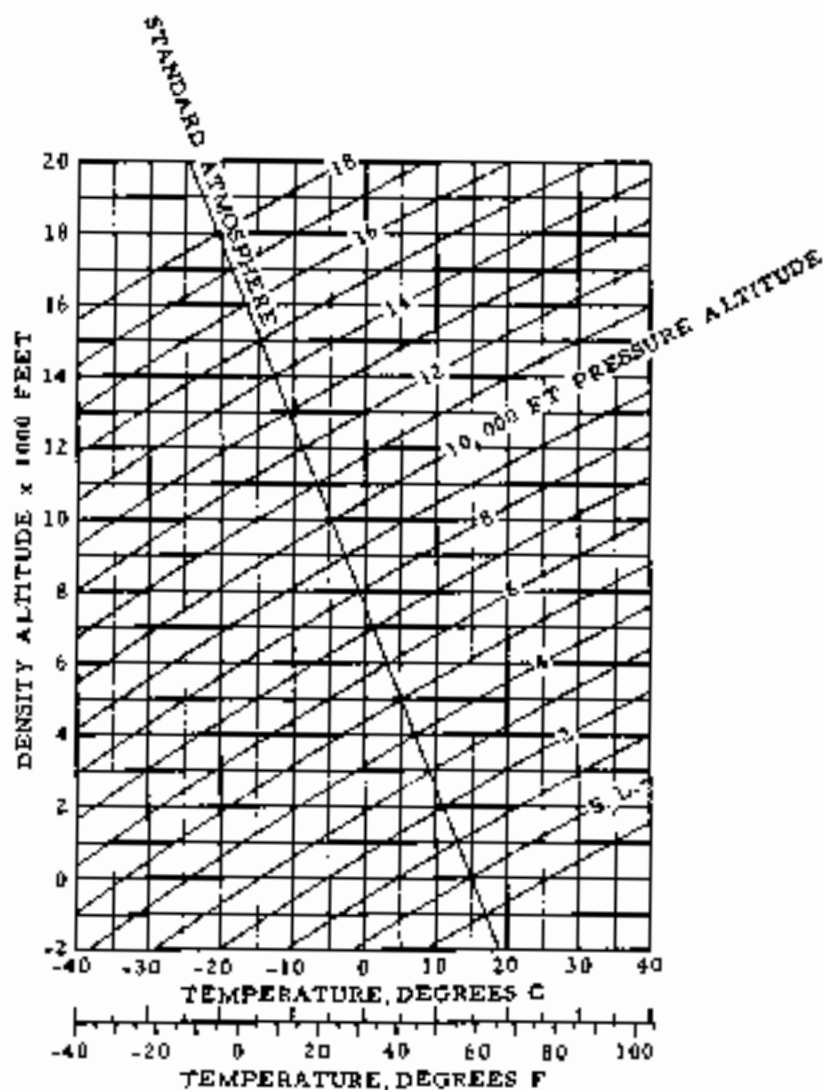

DENSITY ALTITUDE CHART

IN-GROUND LIFT LIFT AT 2 FOOT SKID CLEARANCE
FULL HOISTILE AND 109% RPM

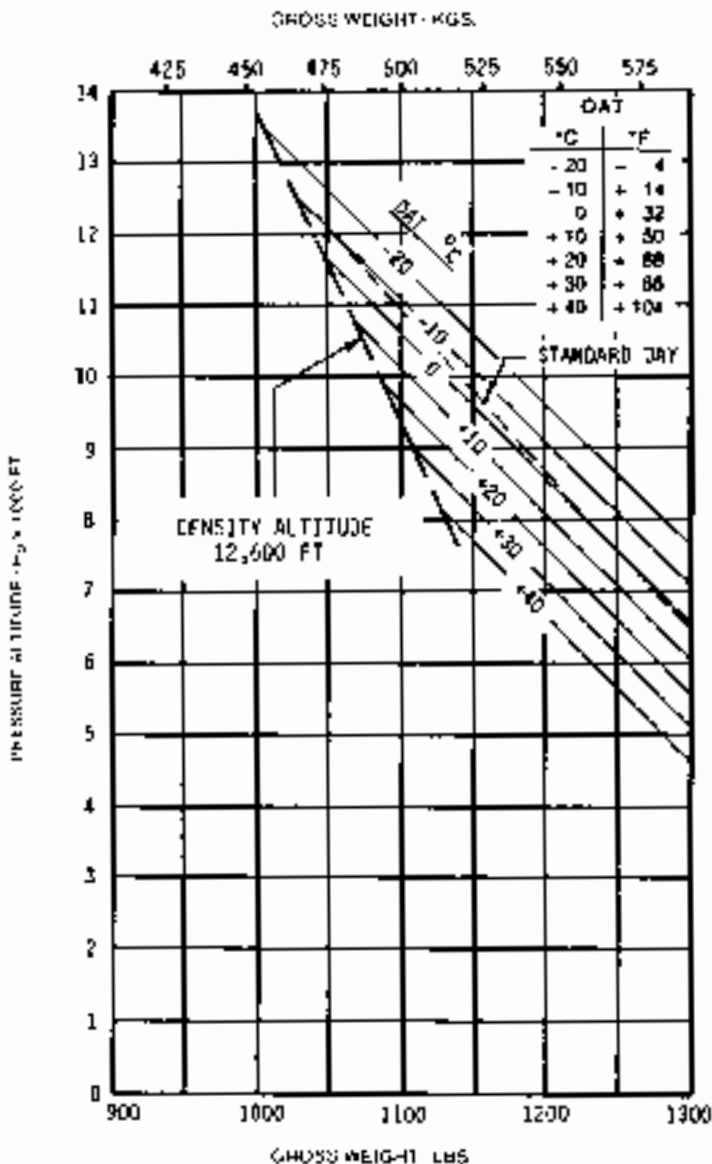

R22 STANDARD
O-320-A2B OR A2C ENGINE

IGE HOVER CEILING VS. GROSS WEIGHT

IN GROUND EFFECT AT 2 FOOT SKID CLEARANCE
FULL THROTTLE
104% RPM
ZERO WIND

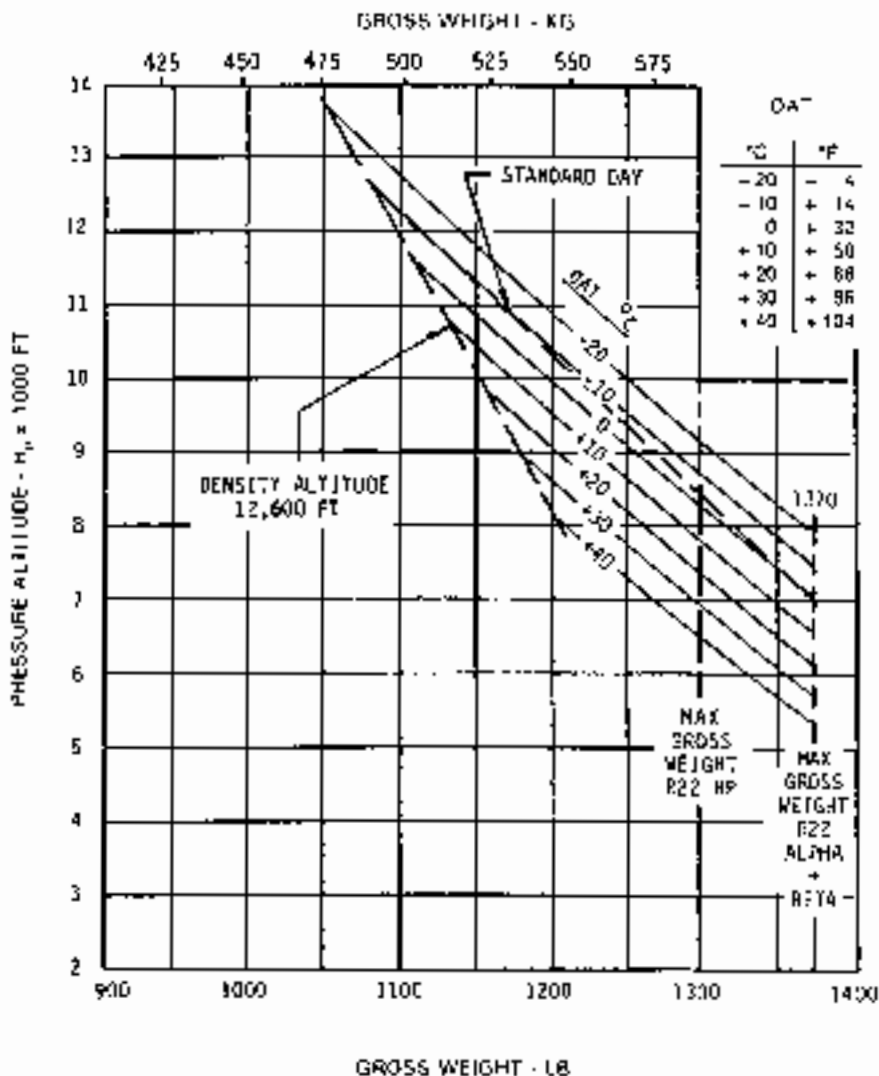

**R22 HP, ALPHA, & BETA
Q-320-B2C ENGINE**

IGE HOVER CEILING VS. GROSS WEIGHT

NO GROUND EFFECT AT 2 FOOT SKID CLEARANCE
FULL THROTTLE
103-104% RPM
ZERO WIND

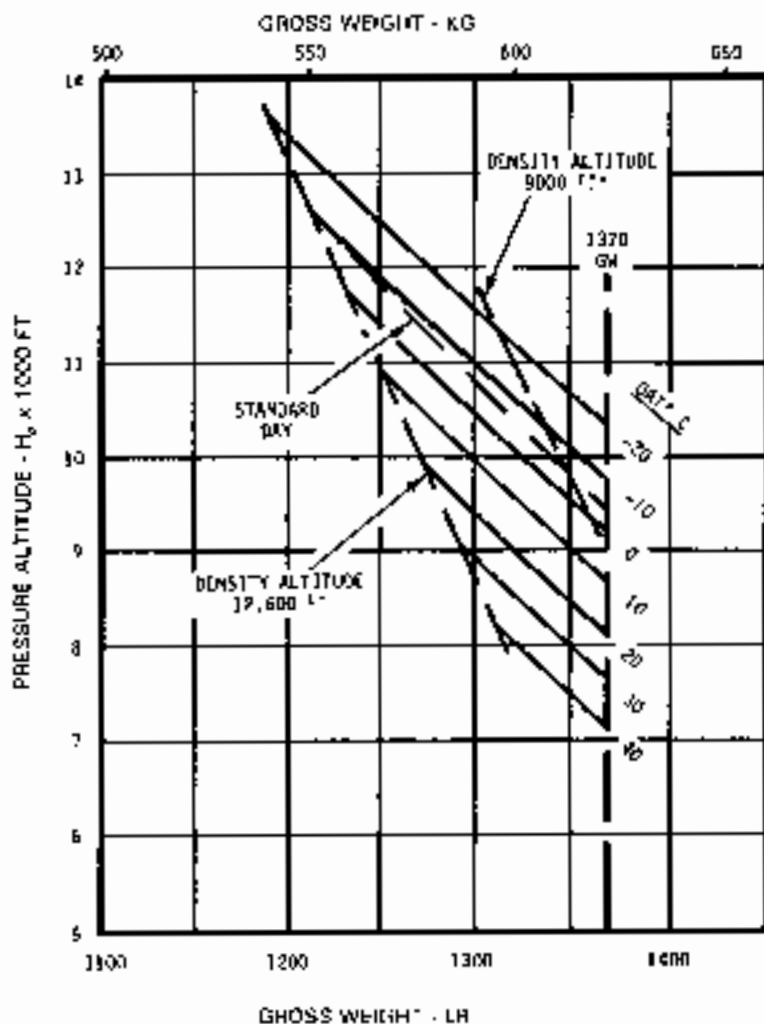

R22 BETA II
O-360-J2A ENGINE

HOVER CEILING VS. GROSS WEIGHT

*Hover controllability with 17 knot wind substantiated up to 9800 feet density altitude.

OUT OF GROUND EFFECT, ZERO WIND
LIMIT MANIFOLD PRESSURE TO CRITICAL ALTITUDE
FULL THROTTLE ABOVE CRITICAL ALTITUDE
104% RPM

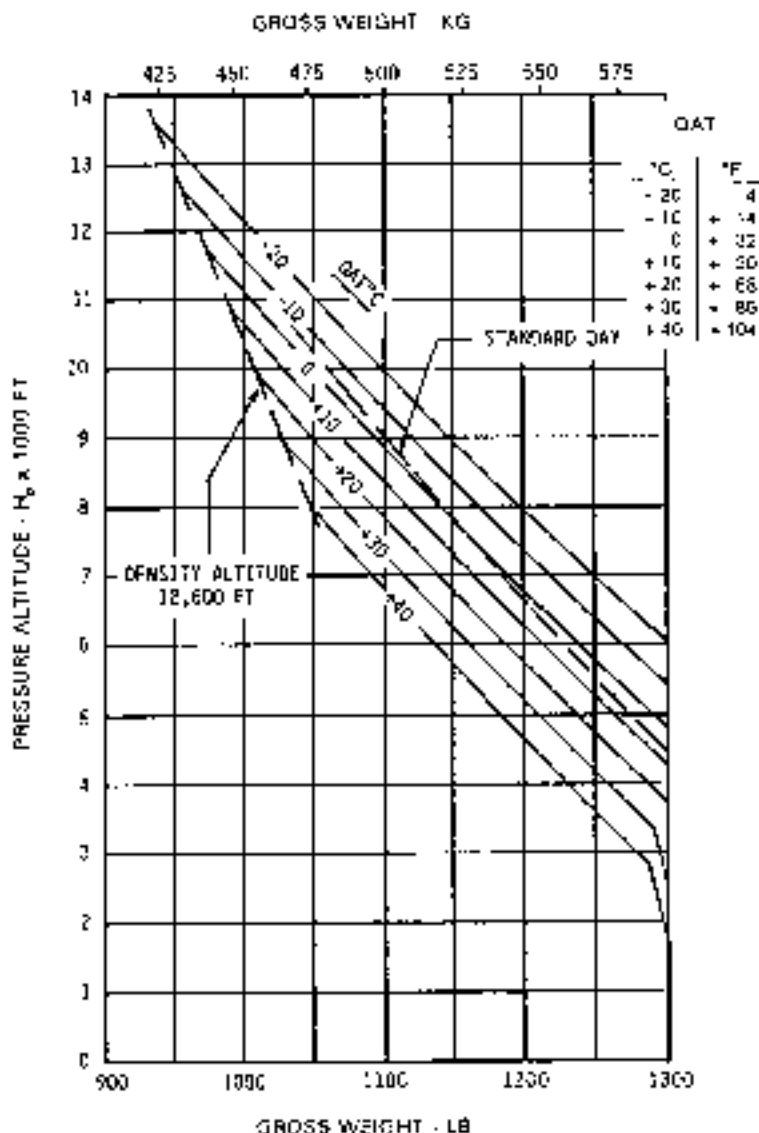

**R22 STANDARD
O-320-A2B OR A2C ENGINE
OGE HOVER CEILING VS. GROSS WEIGHT**

OUT OF GROUND EFFECT, ZERO WIND
LIMIT MANIFOLD PRESSURE TO CRITICAL ALTITUDE
FULL THROTTLE ABOVE CRITICAL ALTITUDE
1049 RPM

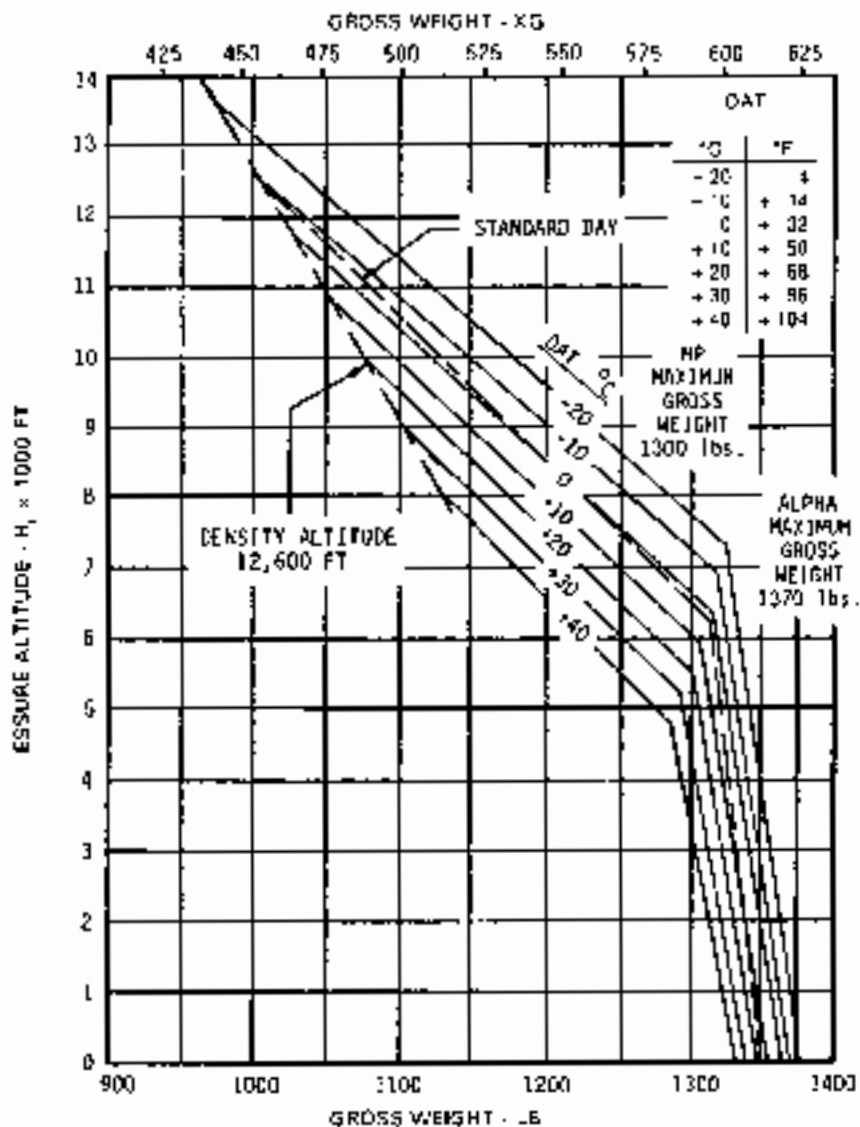

**R22 HP & ALPHA
O-320-B2C ENGINE**

OGE HOVER CEILING VS. GROSS WEIGHT

OUT OF GROUND EFFECT, ZERO WIND
TAKEOFF POWER OR FULL THROTTLE
104% RPM

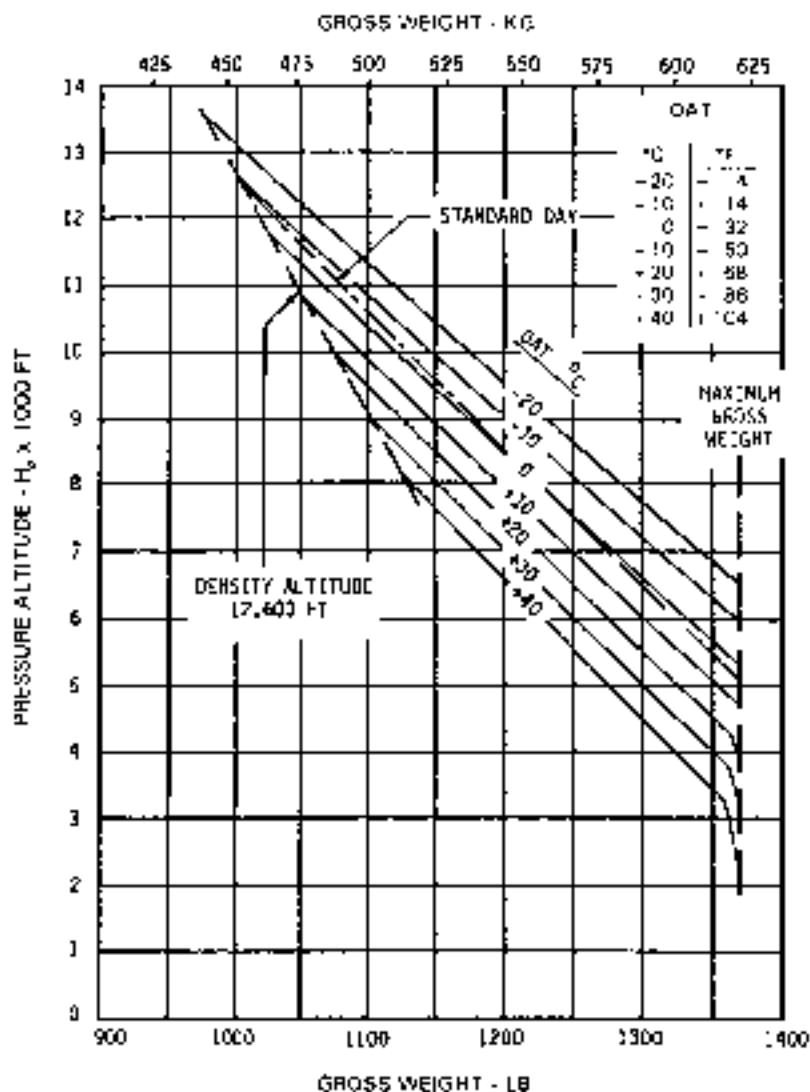

R22 BETA
O-320-B2C ENGINE
OGE HOVER CEILING VS. GROSS WEIGHT

OUT OF GROUND EFFECT, ZERO WIND
TAKEOFF POWER OR FULL THROTTLE
104% RPM

GROSS WEIGHT KG

475 500 525 550 575 600 625 650

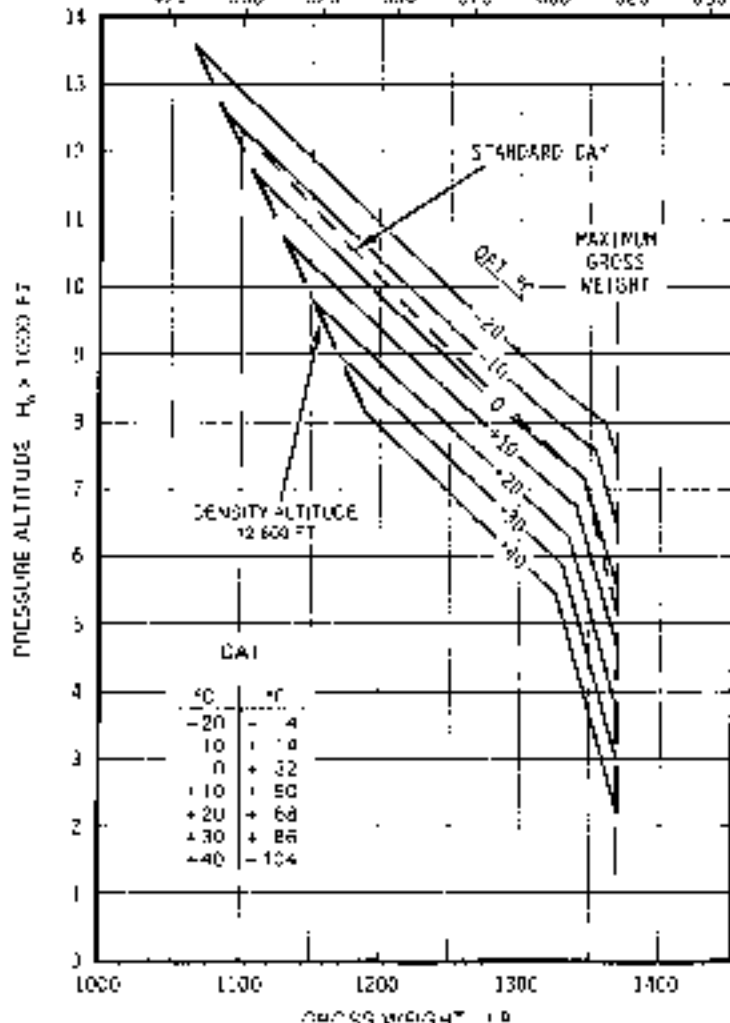

R22 BETA II
O-360-J2A ENGINE

OGE HOVER CEILING VS. GROSS WEIGHT

DEMONSTRATED CONDITIONS:
SMOOTH HARD SURFACE
WIND CALM
103 °04% RPM

AVOID OPERATION IN SHADDED AREAS

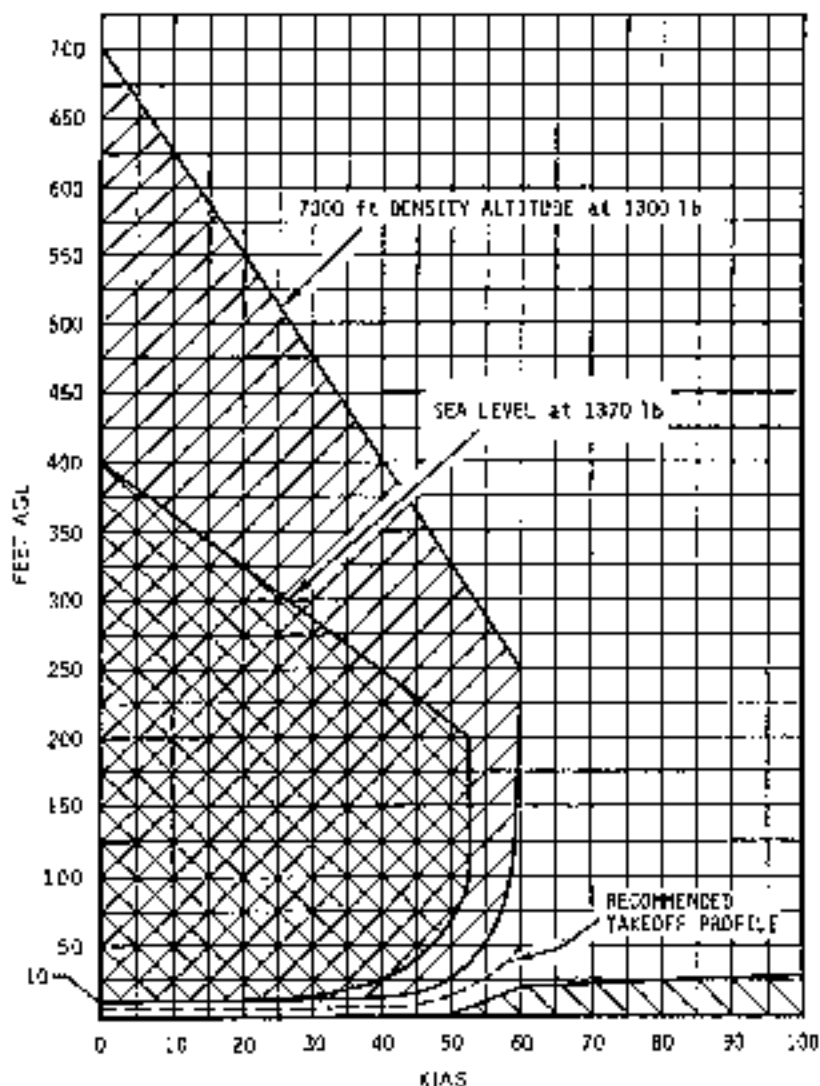

HEIGHT - VELOCITY DIAGRAM

THIS PAGE INTENTIONALLY LEFT BLANK.

SECTION 6

WEIGHT AND BALANCE

CONTENTS

	Page
General	6-1
Weight and Balance Record	6-2
Loading Instructions	6-4

INTENTIONALLY BLANK

SECTION 6

WEIGHT AND BALANCE

GENERAL

The helicopter must be flown only within weight and balance limits specified in Section 2. Loadings outside these limits can result in insufficient control travel for safe operation.

The center of gravity may be adjusted by adding removable ballast (any appropriate item of mass) to an under-seat baggage compartment. Recalculate weight and balance after adding ballast, and verify ballast meets baggage compartment limits given in Section 2.

Loaded helicopter weight and balance can be determined using the method given under **LOADING INSTRUCTIONS**.

In accordance with FAA procedures, the detail weight and balance data of this section are not subject to FAA approval. The loading instructions of this section, however, have been approved by the FAA as satisfying all requirements for instructions on loading of the rotorcraft within approved limits of weight and center of gravity and on maintaining the loading within such limits.

CAUTION

Fuel burn causes CG to move forward during flight. Always determine safe loading with empty fuel as well as with takeoff fuel. Payload may be limited by forward CG as fuel is burned.

WEIGHT AND BALANCE RECORD

The following form should be used to maintain a continuous record of your helicopter's weight and balance. Each time an item of equipment is removed or installed, an entry must be made and the new empty CG determined. The original factory weight and balance and an equipment list is supplied with each helicopter on a form which is inserted at the end of this section. This weight and balance provides the first entry in the Weight and Balance Record form.

NOTE

Calculated CG with full fuel and 135 lb pilot (130 lb pilot without auxiliary fuel tank) must be within CG limits. Following modification, adjustment to fixed nose ballast may be required. See R22 Maintenance Manual.

LOADING INSTRUCTIONS

The following table may be used when calculating loaded helicopter weight and CG position.

COMMON ITEM WEIGHT & CG

Item	Weight (lb)	Longitudinal arm (in.)	Lateral arm (in.) (+ = right side)
Pilot and baggage under right seat		78.0*	+ 10.7
Passenger and baggage under left seat		78.0*	-9.3
Main fuel**		108.6	- 11.0
Aux fuel**		103.8	+ 11.2
Doors	5.2 each	77.5	± 21.0
Removable cyclic	0.8	68.0	-8.0
Removable collective	1.0	80.7	- 19.5
Removable pedals (both pedals)	0.8	46.5	-9.5

* Use 79.0 in. for aircraft prior to S/N 0256 with early-style seats. If additional backrest cushion is used, subtract thickness of compressed cushion.

** A longitudinal arm of 106.9 in. may be used for combined main and aux fuel.

LOADING INSTRUCTIONS (cont'd)

The following sample calculation demonstrates how to determine loaded helicopter weight and center of gravity. A worksheet is provided on the page following the sample calculation for a weight and balance calculation for your helicopter. These may be compared with the CG limits given in Section 2 to determine safe loading. Both takeoff and empty fuel conditions must be within limits.

Lateral CG usually falls well within limits for conventional loadings. If an unusual lateral installation or loading occurs, lateral CG should be checked against the CG limits given in Section 2. The lateral reference datum is the aircraft centerline with items to the right positive and items to the left negative.

LOADING INSTRUCTIONS (cont'd)

SAMPLE LOADING CALCULATION

Item	Weight (lb)	Location		Moment	
		Long. Arm (in.)	Lat. Arm (in.) + = Right Side	Long. (in.-lb)	Lat. (in.-lb)
Basic empty weight	880	104.0	-0.1	91,520	-88
Remove right door	-5.2	77.5	21.0	-403	-109
Remove left door		77.5	-21.0		
Remove cyclic		68.0	-8.0		
Remove collective		80.7	-19.5		
Remove pedals (both)		46.5	-9.5		
Right seat pilot and baggage	170	78.0	10.7	13,260	1819
Left seat passenger and baggage	160	78.0	-9.3	12,480	-1488
Zero usable fuel weight and CG*	1204.8	97.0	0.1	116,857	134
Usable main fuel at 6 lb/gal.	101.4	108.6	-11.0	11,012	-1115
Usable aux fuel at 6 lb/gal.	56.4	103.8	11.2	5854	632
Takeoff Gross Weight and CG*	1362.6	98.1	-0.3	133,723	-349

* CG location (arm) for loaded helicopter is determined by dividing total moment by total weight.

LOADING INSTRUCTIONS (cont'd)

LOADING CALCULATION WORKSHEET

Item	Weight (lb)	Location		Moment	
		Long. Arm (in.)	Lat. Arm (in.) + = Right Side	Long. (in.-lb)	Lat. (in.-lb)
Basic empty weight					
Remove right door		77.5	21.0		
Remove left door		77.5	-21.0		
Remove cyclic		68.0	-8.0		
Remove collective		80.7	-19.5		
Remove pedals (both)		46.5	-9.5		
Right seat pilot and baggage		78.0	10.7		
Left seat passenger and baggage		78.0	-9.3		
Zero usable fuel weight and CG*					
Usable main fuel at 6 lb/gal.		108.6**	-11.0		
Usable aux fuel at 6 lb/gal.		103.8**	11.2		
Takeoff Gross Weight and CG*					

* CG location (arm) for loaded helicopter is determined by dividing total moment by total weight.

** A longitudinal arm of 106.9 in. may be used for combined main and aux fuel. Do not use combined main and aux fuel if calculating lateral arm.

THIS PAGE INTENTIONALLY LEFT BLANK.

SECTION 7

SYSTEMS DESCRIPTION

CONTENTS

	Page
General	7-1
Rotor Systems	7-2
Drive System	7-3
Powerplant	7-3
Flight Controls	7-4
Removable Flight Controls	7-5
RPM Governor	7-6
Control Trim and Friction	7-7
Engine Controls	7-8
Clutch Actuator	7-9
Fuel System	7-10
Electrical System	7-11
Lighting System	7-17
Instrument Panel	7-18
Optional Avionics	7-18
Audio System	7-22
Pitot-Static System	7-23
Dual Tachometer	7-23
Warning and Caution Lights	7-24
Audio Alerts	7-24
Engine Monitoring Unit	7-25
Cabin Heating and Ventilation	7-26
Seats, Belts, and Baggage	7-27
Landing Gear	7-27
Rotor Brake	7-28
Engine Primer System (Optional)	7-28
Carbon Monoxide Detector	7-29
Emergency Locator Transmitter (Optional)	7-30
Accessory Mounts (Optional)	7-31

INTENTIONALLY BLANK

SECTION 7

SYSTEMS DESCRIPTION

GENERAL

The R22 is a two-place, single main rotor, single engine helicopter constructed primarily of metal and equipped with skid-type landing gear.

The primary fuselage structure is welded steel tubing and riveted aluminum sheet. The tailcone is a monocoque structure in which aluminum skins carry primary loads. Fiberglass and thermoplastics are used in the secondary cabin structure, engine cooling shrouds, and various other ducts and fairings. The cabin doors are also constructed of fiberglass and thermoplastics.

A right-side cowl door provides access to the main gearbox and drive system. Additional access to controls and other components for maintenance is provided by removable panels and cowlings.

Stainless steel firewalls are located forward of and above the engine.

Both cabin doors are removable. Refer to Section 8 for removal and installation procedures.

ROTOR SYSTEMS

The main rotor has two all-metal blades mounted to the hub by coning hinges. The hub is mounted to the shaft by a teeter hinge. The coning and teeter hinges use self-lubricated bearings. Droop stops for the main rotor blades provide a teeter hinge friction restraint which normally prevents the rotor from teetering while stopping or starting. Pitch change bearings for each blade are enclosed in a housing at the blade root. The housing is filled with oil and sealed with an elastomeric boot. Each blade has a thick stainless steel spar at the leading edge which is resistant to corrosion and erosion. The skins are bonded to the spar approximately one inch aft of the leading edge. Blades must be refinished if the paint erodes to bare metal at the skin-to-spar bond line. Bond may be damaged if bond line is exposed.

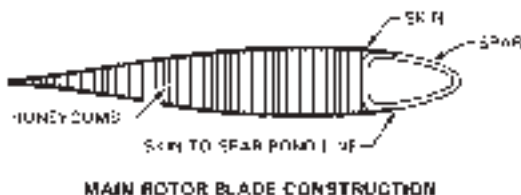

The tail rotor has two all-metal blades and a teetering hub with a fixed coning angle. The pitch change bearings have self-lubricated liners. The teeter hinge bearings are elastomeric or have self-lubricated liners. The tail rotor blades are constructed with aluminum skins and root fittings. Maintaining the paint finish will reduce corrosion and erosion.

DRIVE SYSTEM

A vee-belt sheave is bolted directly to the engine output shaft. Vee-belts transmit power to the upper sheave which has an overrunning clutch contained in its hub. The inner shaft of the clutch transmits power forward to the main rotor and aft to the tail rotor. Flexible couplings are located at the main gearbox input and at each end of the long tail rotor drive shaft.

The main gearbox contains a single-stage spiral-bevel gear set which is splash lubricated. A cooling duct under the box is connected to the top of the engine shroud. The main gearbox is supported by four rubber mounts.

The long tail rotor drive shaft has no support bearings but has a lightly-loaded damper bearing. The tail gearbox contains a single 90° splash-lubricated spiral-bevel gear set.

POWERPLANT

One Lycoming four-cylinder, horizontally-opposed, overhead-valve, air-cooled, carbureted engine with a wet sump oil system powers the helicopter. The engine is equipped with a starter, alternator, shielded ignition, two magnetos, muffler, oil cooler, and induction air filter. See Sections 1 and 2 for powerplant specifications and limitations.

A direct-drive, squirrel-cage fan mounted to the engine output shaft supplies cooling air to the cylinders and oil cooler via a fiberglass and aluminum shroud.

Induction air enters through an inlet on the right side of the fuselage and passes through a flexible duct to the carburetor air box. A hot air scoop supplies heated air to the air box. A sliding valve controlled by the pilot allows either cool or warm air to flow into the box, through the air filter, and up into the carburetor.

The pilot should read and adhere to procedures recommended in the Lycoming Operator's Manual to obtain maximum engine life and efficiency.

FLIGHT CONTROLS

Dual controls are standard equipment and all primary controls are actuated through push-pull tubes and bellcranks. Bearings used throughout the control system are either sealed ball bearings which do not require lubrication or have self-lubricated liners.

Flight control operation is conventional. The cyclic is center mounted with the left and right control grips mounted to a cross tube which pivots on the center cyclic post. On later aircraft, the pilot's cyclic grip angle can be adjusted fore and aft relative to the cross tube by a mechanic to achieve the most comfortable hand position. The most forward position provides the most control clearance at aft cyclic for larger pilots. Pilots should always verify the ability to apply full control travel prior to flight.

Collective operation is conventional. The engine throttle is correlated to collective inputs through a mechanical linkage. When the collective is raised, the throttle is opened and when the collective is lowered, the throttle is closed. The collective stick also incorporates a twist grip throttle control which is described in the Engine Controls section.

CAUTION

Above 4000 feet, throttle-collective correlation and governor are less effective. Therefore, power changes should be slow and smooth.

CAUTION

At high power settings above 4000 feet, the throttle is frequently wide open and RPM must be controlled with collective.

REMOVABLE FLIGHT CONTROLS

Left seat pilot controls may be removed and installed by maintenance personnel or pilots as follows:

1. To remove cyclic grip, remove quick-release pin by depressing button and pulling, then pull outward on left grip while supporting cyclic center post. To install removable cyclic grip, use reverse procedure.

NOTE

Later aircraft have a knurled ring next to the quick-release pin which may be hand tightened to eliminate freeplay. The ring must be loose (rotate counterclockwise looking inboard) to remove pin.

CAUTION

After removing cyclic grip, place plastic cap on exposed cyclic cross tube to prevent possible injury to left seat passenger.

2. To remove collective, push boot aft to expose locking pins. Depress locking pins and pull forward on stick. To install, use reverse procedure. It may be necessary to rotate stick slightly to allow pins to snap into place.

CAUTION

When collective is installed, ensure that both locking pins are fully engaged through holes on each side.

3. To remove tail rotor pedals, depress locking pin while twisting pedal counterclockwise, then pull up. To install, use reverse procedure.

RPM GOVERNOR

The governor maintains engine RPM by sensing changes and applying corrective throttle inputs through a friction clutch which can be easily overridden by the pilot. The governor is active only above 80% engine RPM and can be switched on or off using the toggle switch on the end of the right seat collective.

The governor is designed to assist in controlling RPM under normal conditions. It may not prevent over- or under-speed conditions generated by aggressive flight maneuvers.

CAUTION

When operating at high density altitudes, governor response rate may be too slow to prevent overspeed during gusts, pull-ups, or when lowering collective.

CONTROL TRIM AND FRICTION

Balancing trim springs are incorporated in the cyclic and collective controls. The collective-up spring balances the rotor loads, allowing the pilot to remove his left hand from the collective during most flight regimes. The longitudinal cyclic has a fixed bungee spring which cancels most longitudinal stick forces during cruise flight.

The lateral cyclic is equipped with an on-off trim spring to cancel the left stick force which occurs during high speed flight. The spring is actuated by a push-pull knob located just forward of the cyclic stick. For S/N 550 and subsequent, fine adjustment of the trim force is controlled by the knob located on the left side of the console.

CAUTION

If mixture control is inadvertently pulled in flight, engine stoppage will result. To avoid pulling wrong control, always reach around left side of cyclic center post to actuate lateral trim.

Cyclic and collective controls are equipped with adjustable friction devices. The collective friction lever is located near the aft end of the pilot's collective stick. It is actuated aft to increase friction and forward to release it.

The cyclic friction knob is located left of the cyclic center post. Turning the knob clockwise applies friction to both longitudinal and lateral cyclic.

CAUTION

Control friction must be used with caution during flight. Excessive friction may make the helicopter difficult to control.

The pedals actuate push-pull controls connected directly to the tail rotor pitch control and do not incorporate any trim spring or friction devices.

ENGINE CONTROLS

A twist-grip throttle control is located on each collective stick. The controls are interconnected and actuate the throttle valve through a mechanical linkage. The engine throttle is also correlated to collective inputs through a mechanical linkage. When the collective is raised, the throttle is opened and when the collective is lowered, the throttle is closed.

The electronic engine governor makes minor throttle adjustments by rotating the twist grip to maintain RPM within power-on limits. Manual manipulation of the twist grip is not typically required except during start up, shut down, autorotation practice, and emergencies.

An overtravel spring located in the throttle linkage allows the pilot to roll throttle off beyond the idle stop prior to a ground contact (run-on) autorotation landing. This prevents the throttle from opening when the collective is raised.

Correct throttle linkage adjustment may be verified during preflight by rolling the twist-grip through the overtravel spring and holding against the hard idle stop. The carburetor throttle arm should just barely start to move when the collective is raised full up.

Other engine controls include a mixture control located forward and to the right of the cyclic center post and a carburetor heat control located to the right and aft of the cyclic. R22s with O-360 engines are equipped with Carb Heat Assist which is described in Section 4.

CAUTION

In-flight leaning with mixture control is not recommended. If mixture is leaned on the ground at high altitude, be sure it is pushed back in before descending to lower altitude. Otherwise, engine may quit.

NOTE

On some aircraft, the mixture control is located on the console face. The mixture guard is not used with this mixture control.

CLUTCH ACTUATOR

After the engine is started, it is coupled to the rotor drive system through vee-belts which are tensioned by raising the upper drive sheave. An electric actuator, located between the drive sheaves, raises the upper sheave when the pilot engages the clutch switch. The actuator senses compressive load (belt tension) and switches off when the vee-belts are properly tensioned. The clutch caution light illuminates whenever the actuator circuit is energized, either engaging, disengaging, or retensioning the belts. The light stays on until the belts are properly tensioned or completely disengaged.

Belt slack during engine start should be adjusted such that blades begin turning within five seconds of clutch engagement. Excessive slack may cause belts to jump out of sheave grooves during start. Periodic readjustment by a mechanic may be required as belts wear in service.

A fuse located on or near the test switch panel prevents an actuator motor overload from tripping the circuit breaker. If the fuse blows, the actuator motor will stop but the clutch caution light will remain illuminated. An open circuit breaker removes power from both the motor and the light. With an open circuit breaker, no belt tensioning will occur, and the light will not function to indicate an abnormal condition.

CAUTION

Never take off while clutch caution light is on.

FUEL SYSTEM

The fuel system is gravity-flow (no fuel pumps) and includes a main tank, an optional auxiliary tank, a shutoff valve control located behind the left seat, and a strainer (gascolator). Fuel tanks on later aircraft have flexible bladders in aluminum enclosures while earlier aircraft use all-aluminum tanks. Fuel tank air vents are located inside the mast fairing.

Plunger-style drain valves are provided for the gascolator and for each fuel tank sump. The gascolator is located on the lower left side of the firewall. The drain valves for the auxiliary tank and bladder-style main tank are located inside the cowl door below the auxiliary tank. Plastic tubes attached to the valves allow fuel to be drained overboard. Fuel samples are taken by pushing on the plunger(s). For all-aluminum main tanks, the drain is located on the left side of the fuselage and is opened by pushing in on the plastic tube. On newer helicopters, a glass tube stowed inside the upper, aft cowl door is provided which may be used to catch the fuel samples. Fuel should be sampled from all three locations prior to the first flight of the day and after refueling to verify no contamination and correct grade.

The fuel gages are electrically operated by float-type transmitters in the tanks. When the gages read E the tanks are empty except for a small quantity of unusable fuel. The low fuel caution light is actuated by a separate electric sender located on the bottom of the main tank.

The auxiliary tank is interconnected with the main tank and is located somewhat higher so it will become empty first while fuel still remains in the main tank. The fuel shutoff valve controls flow from both tanks to the engine.

ELECTRICAL SYSTEM

A 14-volt DC electrical system which includes an alternator and a sealed lead-acid battery is standard. The battery is located either in the engine compartment or beneath the instrument console.

The circuit breaker panel is on the ledge just forward of the left seat. Breakers are marked to indicate function and amperage. Inflight reset of circuit breakers is not recommended.

The battery switch controls the battery relay which disconnects the battery from the electrical system. A wire protected by a fuse near the battery bypasses the battery relay to allow both tachometers and the clock to continue to receive battery power with the battery switch off.

The alternator control unit protects the electrical system from overvoltage conditions. The ammeter indicates current to the battery ("—" indicates discharge). An ALT caution light or ammeter discharge indication in flight indicates low voltage and possible alternator failure. Turn off nonessential electrical equipment and switch alternator off then back on after one second to reset alternator control unit. If ALT light stays on or ammeter still indicates discharge, land as soon as practical.

CAUTION

Continued flight without functioning alternator can result in loss of power to tachometers, producing a hazardous flight condition.

NOTE

Except for emergency procedures, do not operate alternator with battery switched off. The battery helps protect electrical equipment from voltage spikes.

Later aircraft have an avionics master switch which controls power to the avionics bus. This allows all avionics to be switched on and off by a single switch.

ELECTRICAL SYSTEM (cont'd)

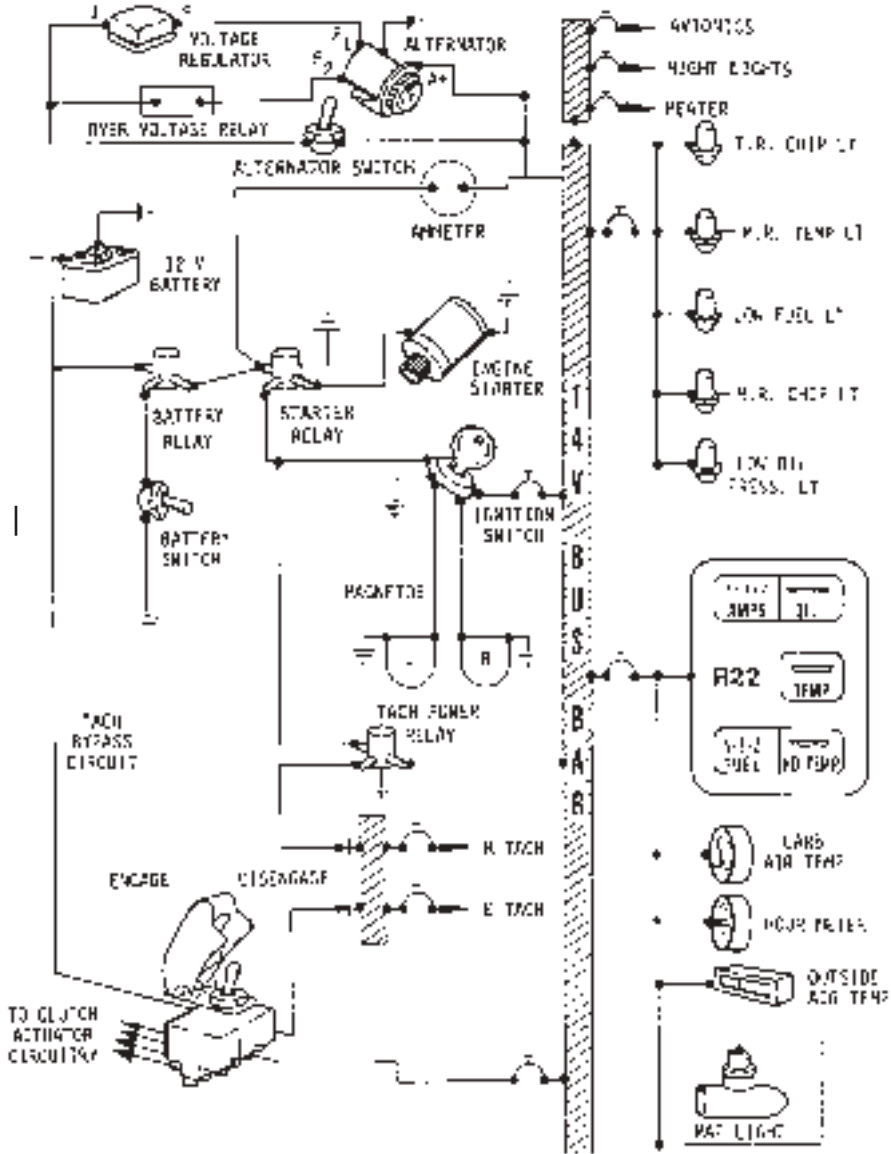

ELECTRICAL SYSTEM
R22 STANDARD & HP

ELECTRICAL SYSTEM (cont'd)

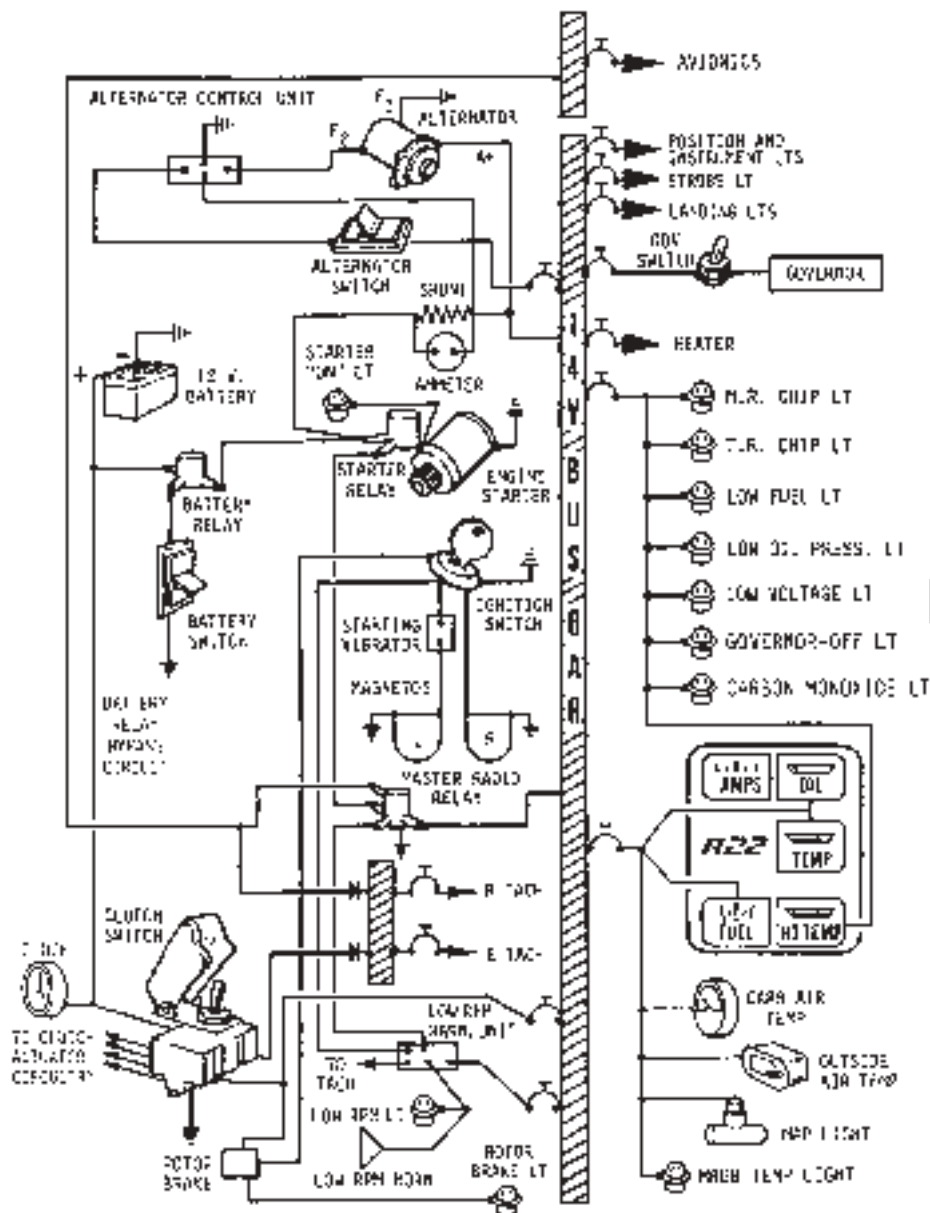

ELECTRICAL SYSTEM
ALPHA, BETA, & EARLIER BETA II

ELECTRICAL SYSTEM (cont'd)

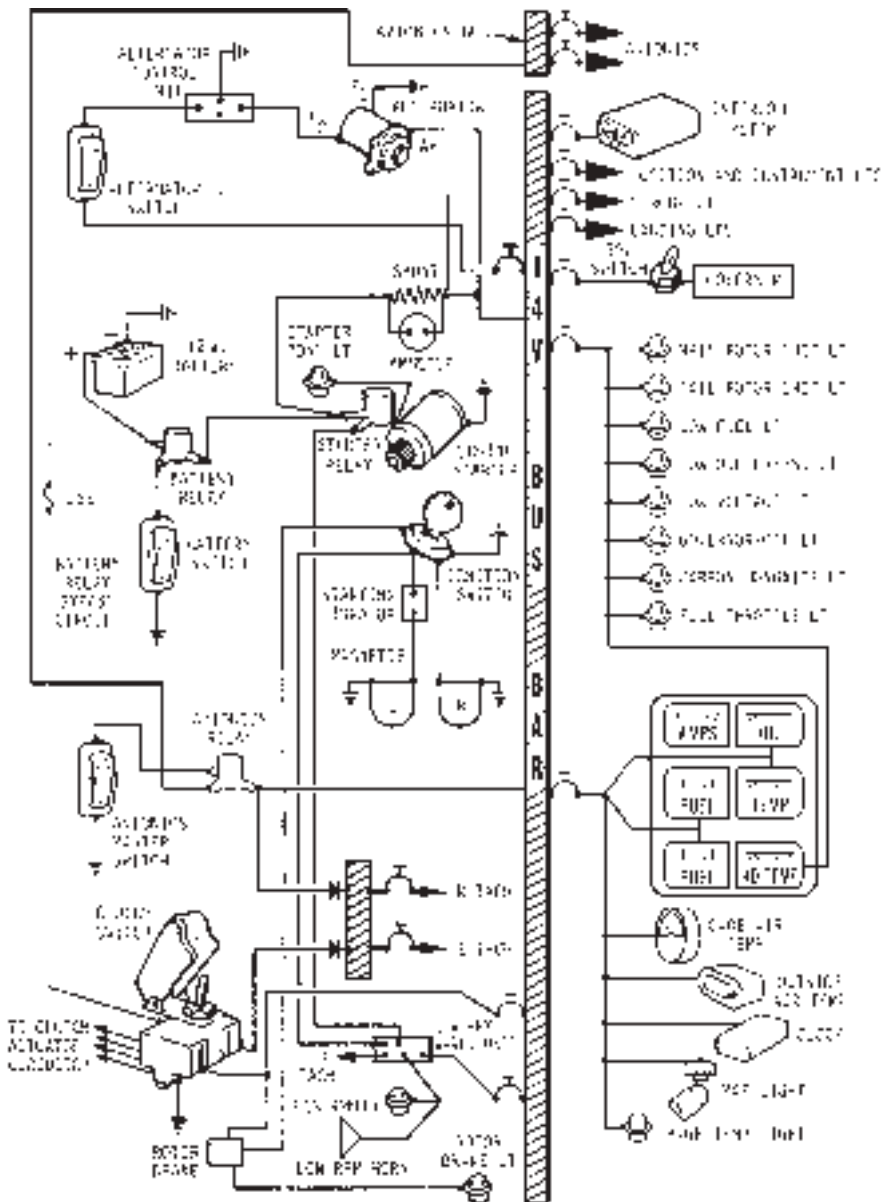

ELECTRICAL SYSTEM
LATER BETA II

ELECTRICAL SYSTEM (cont'd)

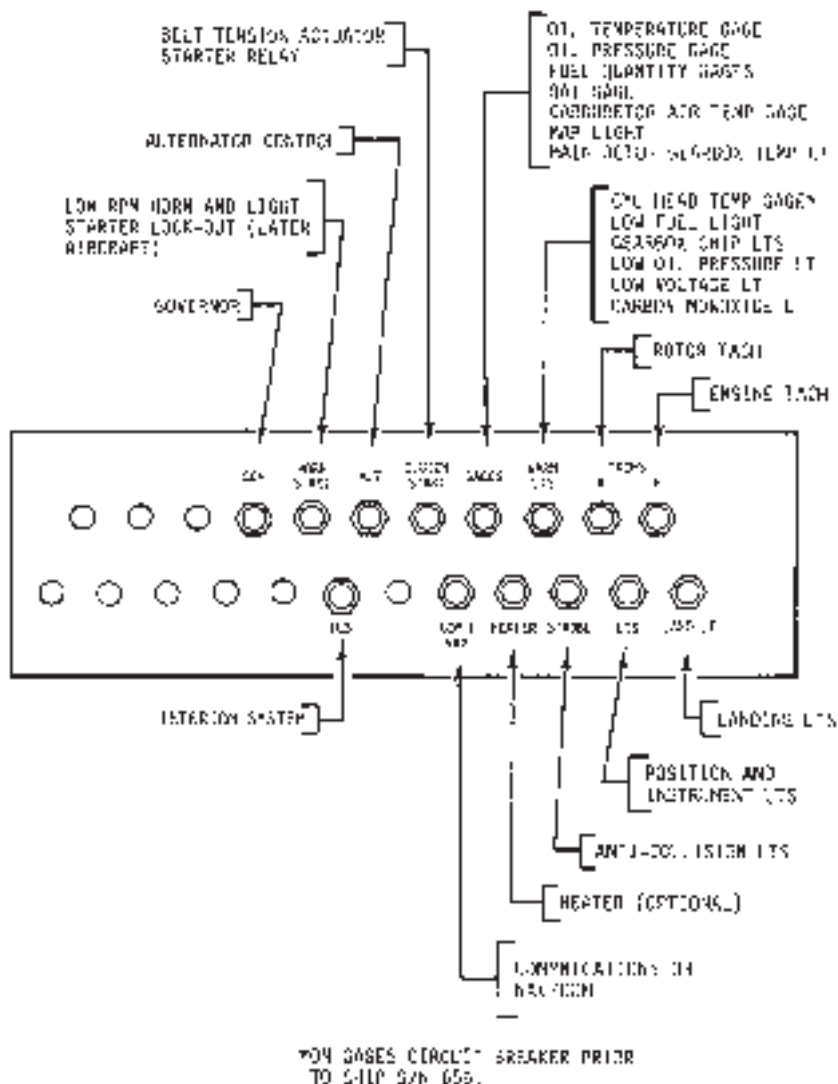

CIRCUIT BREAKER PANEL – TYPICAL (EARLIER AIRCRAFT)

ELECTRICAL SYSTEM (cont'd)

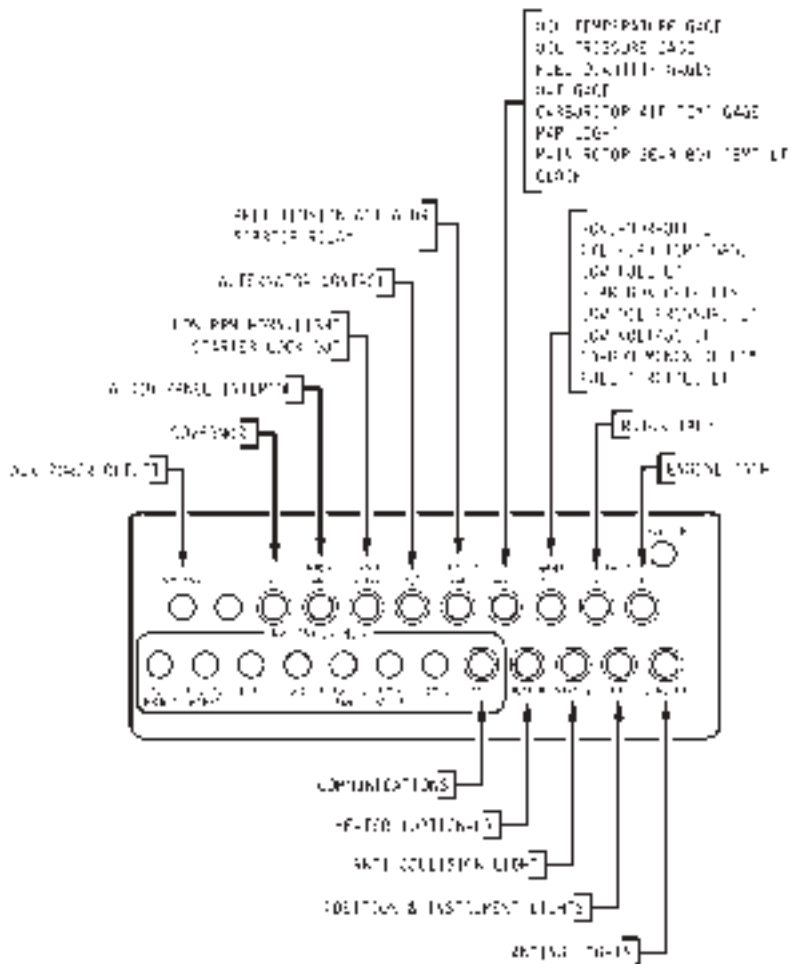

CIRCUIT BREAKER PANEL – TYPICAL (LATER AIRCRAFT)

LIGHTING SYSTEM

A red anti-collision light is installed on the tailcone and is controlled by the strobe switch. Position lights are installed on each side of the cabin and in the tail and are controlled by the nav lights switch. Post and internal lights (earlier aircraft) or a light at the top of the windshield (later aircraft) illuminate the instruments. Instrument lighting is active when the nav lights switch is on and lighting is dimmed via the knob above the nav lights switch. An overhead map light mounted on a swivel is controlled by an adjacent switch. The map light may be used for emergency lighting of the instrument panel.

Two landing lights are installed in the nose at different vertical angles to increase the lighted area. One landing light switch controls both lights and is located on the cyclic center post.

NOTE

Landing lights operate only when clutch actuator switch is in the engage position.

NOTE

Continuous operation of landing and position lights in flight is recommended to promote collision avoidance.

INSTRUMENT PANEL

Standard primary instruments include an airspeed indicator, engine and rotor dual tachometer, altimeter, manifold pressure gage, and magnetic compass. Engine gages include an ammeter, oil pressure, oil temperature, cylinder head temperature, and fuel quantity for main and aux (if installed) tanks. Also standard are a clock, a carburetor air temperature gage, and a digital outside air temperature gage. An hourmeter is located on the ledge just forward of the pilot's seat.

Views of typical instrument panels are given on the following pages. Pilots should familiarize themselves with panel layout and equipment installations for each specific aircraft that they fly.

OPTIONAL AVIONICS

A wide range of optional avionics are available for the R22. It is not practical to provide a description of all equipment in this manual. All aircraft are delivered with the manufacturers' operating manuals for each piece of installed equipment. Pilots are referred to the manufacturers' manuals for detailed operating instructions. Additional information for more complex options such as primary flight displays (PFDs) may be found in the Optional Avionics Supplement in Section 9. Good practice dictates becoming familiar with installed equipment before operating an aircraft.

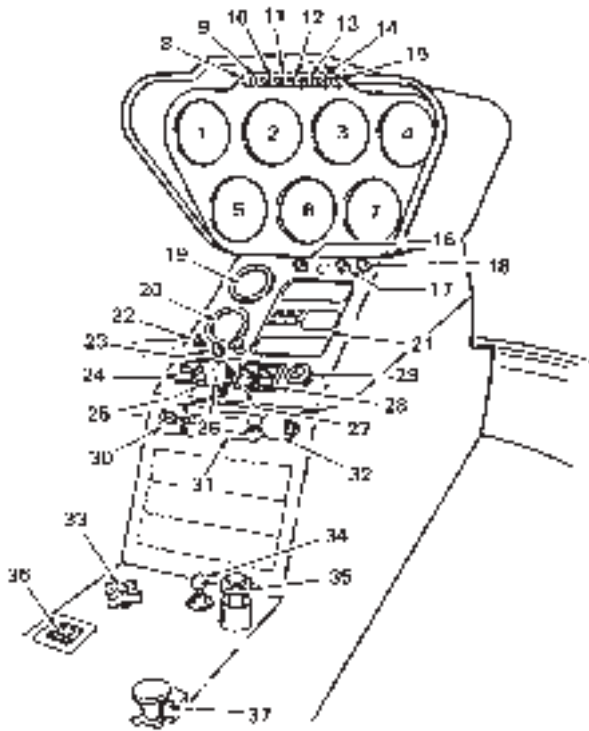

- | | |
|-----------------------------|--------------------------------|
| 1. VERTICAL SPEED INDICATOR | 20. CARB AIR TEMP OR CLOCK |
| 2. OPTIONAL INSTRUMENT | 21. ENGINE INSTRUMENTS |
| 3. AIRSPEED INDICATOR | 22. PANEL LIGHTS DIMMER |
| 4. ENGINE AND ROTOR TACHS | 23. ROTOR BRAKE LIGHT |
| 5. ALTIMETER | 24. NAVIGATION LIGHTS SWITCH |
| 6. OPTIONAL INSTRUMENT | 25. STROBE LIGHT SWITCH |
| 7. MANIFOLD PRESSURE GAGE | 26. CLUTCH ACTUATOR SWITCH |
| 8. CLUTCH ACTUATOR LIGHT | 27. ALTERNATOR SWITCH |
| 9. M.R. GEARBOX TEMP LIGHT | 28. BATTERY SWITCH |
| 10. M.R. GEARBOX CHIP LIGHT | 29. IGNITION SWITCH |
| 11. CARBON MONOXIDE LIGHT | 30. INTERCOM |
| 12. STARTER-ON LIGHT | 31. OUTSIDE AIR TEMP/VOLTMETER |
| 13. T.R. GEARBOX CHIP LIGHT | 32. CABIN AIR |
| 14. LOW FUEL LIGHT | 33. CYCLIC FRICTION |
| 15. LOW RPM LIGHT | 34. CYCLIC RIGHT TRIM |
| 16. ALT LOW VOLTAGE LIGHT | 35. MIXTURE CONTROL |
| 17. OIL PRESSURE LIGHT | 36. ELT SWITCH (OPTIONAL) |
| 18. GOVERNOR-OFF LIGHT | 37. CARBURETOR HEAT |
| 19. CLOCK OR CARB AIR TEMP | |

INSTRUMENT PANEL – TYPICAL (EARLIER AIRCRAFT)

(Exact panel configuration may vary with optional equipment and date of helicopter manufacture.)

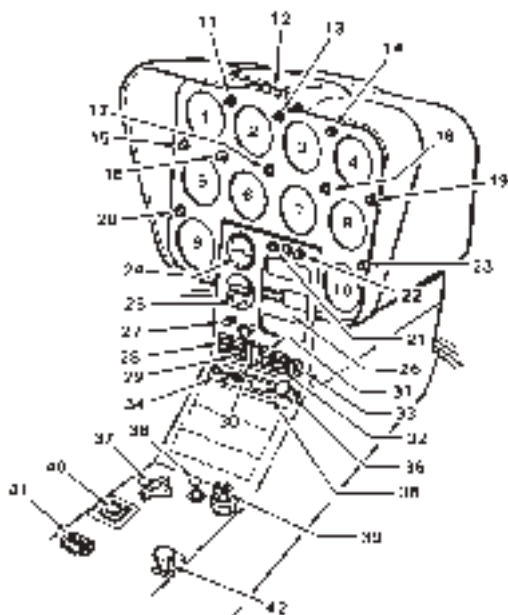

- | | |
|-----------------------------|------------------------------|
| 1. ENGINE AND ROTOR TACHS | 22. OIL PRESSURE LIGHT |
| 2. AIRSPEED INDICATOR | 23. ROTOR BRAKE LIGHT |
| 3. ARTIFICIAL HORIZON | 24. CARBURETOR AIR TEMP |
| 4. ALTIMETER | 25. CLOCK |
| 5. MANIFOLD PRESSURE GAGE | 26. ENGINE INSTRUMENTS |
| 6. TURN COORDINATOR | 27. PANEL LIGHTS DIMMER |
| 7. HSI | 28. NAVIGATION LIGHTS SWITCH |
| 8. VERTICAL SPEED INDICATOR | 29. STROBE LIGHT SWITCH |
| 9. OPTIONAL INSTRUMENT | 30. CLUTCH ACTUATOR SWITCH |
| 10. OPTIONAL INSTRUMENT | 31. ALTERNATOR SWITCH |
| 11. M.R. GEARBOX TEMP LIGHT | 32. BATTERY SWITCH |
| 12. MARKER BEACON | 33. IGNITION SWITCH |
| 13. T.R. GEARBOX CHIP LIGHT | 34. INTERCOM |
| 14. M.R. GEARBOX CHIP LIGHT | 35. OUTSIDE AIR TEMP |
| 15. STARTER-ON LIGHT | 36. CABIN AIR |
| 16. LOW RPM LIGHT | 37. CYCLIC FRICTION |
| 17. LOW FUEL LIGHT | 38. CYCLIC RIGHT TRIM |
| 18. CARBON MONOXIDE LIGHT | 39. MIXTURE CONTROL |
| 19. CLUTCH ACTUATOR LIGHT | 40. ELT SWITCH (OPTIONAL) |
| 20. GOVERNOR-OFF LIGHT | 41. HSI SLAVE CONTROL |
| 21. ALT LOW VOLTAGE LIGHT | 42. CARBURETOR HEAT |

OPTIONAL INSTRUMENT PANEL (EARLIER AIRCRAFT)

(Exact panel configuration may vary with optional equipment and date of helicopter manufacture.)

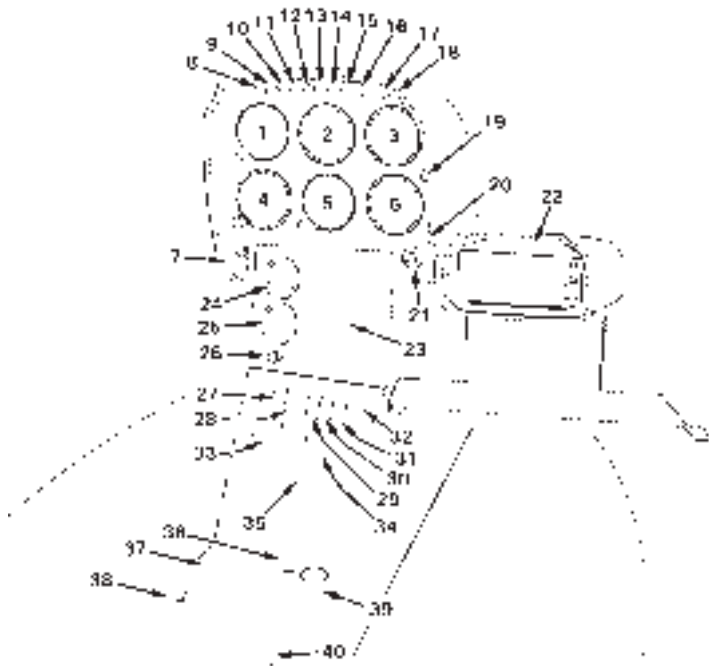

- | | |
|-----------------------------|----------------------------------|
| 1. VERTICAL SPEED INDICATOR | 21. IGNITION SWITCH |
| 2. AIRSPEED INDICATOR | 22. PILOT'S SIDE CONSOLE (OPT'L) |
| 3. ENGINE AND ROTOR TACHS | 23. ENGINE INSTRUMENTS |
| 4. OPTIONAL INSTRUMENT | 24. CARBURETOR AIR TEMP |
| 5. ALTIMETER | 25. CLOCK |
| 6. MANIFOLD PRESSURE GAGE | 26. PANEL LIGHTS DIMMER |
| 7. CLUTCH ACTUATOR SWITCH | 27. NAVIGATION LIGHTS SWITCH |
| 8. CLUTCH ACTUATOR LIGHT | 28. ANTI-COLLISION LIGHT SWITCH |
| 9. M.R. GEARBOX TEMP LIGHT | 29. AVIONICS MASTER SWITCH |
| 10. M.R. GEARBOX CHIP LIGHT | 30. ALTERNATOR SWITCH |
| 11. CARBON MONOXIDE LIGHT | 31. BATTERY SWITCH |
| 12. STARTER-ON LIGHT | 32. CABIN AIR |
| 13. T.R. GEARBOX CHIP LIGHT | 33. INTERCOM |
| 14. LOW FUEL LIGHT | 34. OUTSIDE AIR TEMP/VOLTMETER |
| 15. LOW RPM LIGHT | 35. AVIONICS STACK |
| 16. ALT LOW VOLTAGE LIGHT | 36. CYCLIC RIGHT TRIM |
| 17. OIL PRESSURE LIGHT | 37. CYCLIC FRICTION |
| 18. GOVERNOR-OFF LIGHT | 38. ELT SWITCH (OPTIONAL) |
| 19. FULL THROTTLE LIGHT | 39. MIXTURE CONTROL |
| 20. ROTOR BRAKE LIGHT | 40. CARBURETOR HEAT |

INSTRUMENT PANEL – TYPICAL (LATER AIRCRAFT)

(Exact panel configuration may vary with optional equipment and date of helicopter manufacture.)

AUDIO SYSTEM

A voice-activated intercom/audio system is standard and is controlled by a small control panel above the avionics stack. The ICS volume knob controls intercom volume but does not affect radio volume. The VOX squelch knob is used to set the threshold volume at which the intercom is activated. When the VOX knob is turned fully clockwise, keying is required to activate the intercom. Later intercom systems include a music input jack located on the circuit breaker panel. This input is muted when the intercom is active, when transmitting, and during reception of radio signals.

Headset jacks are located in the ceiling near each seat. The cyclic grips are equipped with either transmit and intercom buttons or trigger-style intercom/transmit switches. For the trigger-style switch, the first detent activates the intercom and the second detent transmits. An additional intercom button is located on the left-hand floor or seat support.

Earlier R22s are equipped with an intercom system that operates in either push-to-talk (PTT) or hot mic modes. A toggle switch to the left of the cyclic center post is used to change modes. In PTT mode, the intercom is activated using the intercom buttons.

Audio control panels from several manufacturers are offered as options in place of the standard intercom system. Pilots should consult the manufacturer's operating instructions if an audio panel is installed.

PITOT-STATIC SYSTEM

The pitot-static system supplies air pressure to operate the airspeed indicator, altimeter, and vertical speed indicator. The pitot tube is located on the front edge of the mast fairing. The static source is located inside the aft cowling inboard of the cowl door hinge.

Water can be drained from pitot-static lines by removing the plastic drain plugs which are accessible through the inspection panel on the underside of the cabin. Draining lines should only be required if the airspeed indicator or altimeter appears erratic.

Pitot and static sources should be inspected frequently to verify no bugs or other obstructions.

DUAL TACHOMETER

An electronic engine and rotor dual tachometer is standard. Engine tachometer signal is provided by magneto breaker points. Rotor tachometer signal is provided by two magnetic senders at the main gearbox drive yoke. Each tachometer is on a separate circuit with its own circuit breaker. With battery and alternator switches off, the tachometers continue to receive power from the battery through a bypass circuit as long as the clutch actuator switch is in the engage position.

NOTE

Do not stow helicopter with clutch switch engaged. The tachometers are powered with the clutch engaged and will discharge the battery.

WARNING AND CAUTION LIGHTS

Warning and caution lights include clutch, main gearbox over-temperature, main and tail gearbox chip, starter on (later aircraft), low fuel, low RPM, alternator, low oil pressure, rotor brake, governor off, carbon monoxide (aircraft with cabin heater), and full throttle (later aircraft). The clutch light indicates that the clutch actuator is operating. The low RPM light and horn indicate rotor RPM at 97% or below. The low oil pressure and low fuel lights are actuated by sensors in those systems and are independent of the gage indicators. The alternator light warns of a possible alternator failure. The governor-off light indicates the RPM governor is switched off.

The main and tail gearbox chip detectors are magnetic devices located in the drain plug of each gearbox. When metallic particles are drawn to the magnets they close an electrical circuit, illuminating the caution light. Metal particles may be caused by a failing bearing or gear, thus giving warning of impending gearbox failure. The main gearbox over-temp light is actuated by a temperature switch located near the input pinion.

The carbon monoxide light is actuated by a sensor above the pilot's heater outlet and indicates elevated cabin carbon monoxide levels.

The full throttle light is activated by a switch in the throttle linkage and indicates that the engine is near full throttle.

AUDIO ALERTS

All R22 helicopters have a low-RPM horn which sounds when rotor RPM is below 97%. The horn is muted when the collective is fully down. On earlier aircraft, the horn is provided by a speaker in the side of the instrument console. On later aircraft, a tone generator in the audio system provides the horn through crew headsets.

Later aircraft include a high rotor RPM alert through the headsets. A warble tone (high/low tone) indicates rotor RPM is approaching 110%. A test button on the instrument panel permits pre-flight or in-flight testing of the high-RPM alert.

AUDIO ALERTS (Cont'd)

Additional audio alerts may be provided in the headsets depending on optional equipment installed, such as terrain and traffic warnings.

ENGINE MONITORING UNIT

Later aircraft are equipped with an Engine Monitoring Unit (EMU), which is a digital recording device within the engine RPM governor control box. The EMU continuously monitors engine and rotor speed, engine oil temperature, cylinder head temperature, manifold pressure, ambient pressure, and outside air temperature.

EMU status is indicated by an amber light located in the right-side baggage compartment on the aft seat support panel. The EMU requires approximately ten seconds to complete a self-test after the aircraft battery is switched on. Once the self-test is complete, steady illumination of the light means normal EMU operation. A slowly flashing light (once every two seconds) or no light means there is a fault in the EMU's senders or circuitry. A fast flashing light (four times per second) indicates the EMU has detected an exceedance. EMU data can be downloaded to a computer with the appropriate software. A fault or exceedance should be investigated and the indication reset by a qualified mechanic prior to the next flight. Current exceedances may be reviewed (but not reset) on an Apple mobile device using an application available through the Robinson website.

The EMU is intended to be used only as a maintenance aid. It remains the pilot's responsibility to report any observed exceedances.

CABIN HEATING AND VENTILATION

Fresh air vents are located in each door and in the nose. Door vents are opened and closed using the knob near the vent door hinge. On earlier aircraft, pushing in on the knob will seal and lock the door vents closed. On later aircraft, a rotating knob is provided to lock the vents. For maximum ventilation, open door vents wide during hover but only one inch or less during cruise. The rotating knob can be used to hold vents partially open.

The fresh air inlet in the nose is opened by pulling the cabin air knob on the console face. Air from the nose inlet is directed along inside surface of the windshield for defogging as well as for ventilation.

A cabin heater is optional. It consists of a muffler heat shroud, a control valve at the firewall, an outlet grille forward of the tail rotor pedals, and interconnecting ducting. A heater control knob located on the ledge forward of the pilot's seat actuates the valve which directs heat either into the cabin or out an overboard discharge on the cabin underside. Earlier aircraft have an electric blower with a switch next to the control knob to turn the blower on. On later aircraft, heater air is taken from the engine cooling shroud and a blower is not required.

CAUTION

In case of an in-flight engine fire, heater control knob should be pushed off to seal cabin area from engine compartment.

NOTE

On aircraft with a heater blower, have the heater shroud removed during warm seasons to prolong muffler life.

SEATS, BELTS, AND BAGGAGE

The seats are not adjustable but each helicopter is supplied with a cushion which can be placed behind the pilot to position him farther forward. This allows shorter pilots to reach the pedals, the cyclic grip in its most forward position, and controls on the center console.

Each seat is equipped with a combined lap belt and inertia reel shoulder strap. The inertia reel is normally free but will lock if there is sudden movement as would occur in an accident.

A baggage compartment is located under each seat. Seat cushions hinge forward for access.

LANDING GEAR

A skid-type landing gear is used. Most hard landings will be absorbed elastically. However, in an extremely hard landing, the struts will hinge up and outward as the crosstube yields (becomes permanently bent) to absorb the impact. Slight crosstube yielding is acceptable. However, yielding which allows the tail skid to be within 34 inches (24 inches for R22 Standard or HP) of the ground when the helicopter is sitting empty on level pavement requires crosstube replacement.

Abrasion-resistant wear shoes are mounted on the bottom of the skids. These shoes should be inspected periodically, particularly if autorotation landings with ground contact have been performed. Have skid shoes replaced whenever the thinnest point in the wear area is less than 0.06 inches (1.5 mm).

ROTOR BRAKE

If installed, the rotor brake is mounted on the aft end of the main gearbox and is actuated by a cable connected to a pull handle located above and behind the pilot's left shoulder. To stop the rotor, use the following procedure:

1. After pulling mixture off, wait at least 30 seconds.
2. Pull brake handle forward and down using moderate force (approximately 10 lb).
3. After rotor stops, it is recommended to use the rotor brake as a parking brake by hooking bead chain in slot in bracket.

The brake must be released before starting the engine. When the brake is engaged, the starter is disabled.

CAUTION

Applying rotor brake without waiting at least 30 seconds after engine stops or using a force which stops rotor in less than 20 seconds may damage brake shoes.

ENGINE PRIMER SYSTEM (OPTIONAL)

The primer is used to improve engine cold starting. The primer pump is located in front of the right seat near the hourmeter. Engine priming is performed as follows:

1. Unlock pump handle and pump as required for priming (normally two to three strokes). Pull handle up slowly to allow time for fuel to fill pump.
2. After priming, push handle full down and lock.

CARBON MONOXIDE DETECTOR

The carbon monoxide (CO) detector, if installed, indicates elevated cabin CO levels. CO is an odorless, toxic gas present in engine exhaust which causes headaches, drowsiness, and possible loss of consciousness. CO levels may become elevated due to an exhaust leak or exhaust recirculation during prolonged hovering.

The CO detector system consists of a sensor above the pilot's heater outlet and a caution light. A system check (light flashes twice) is performed each time power is switched on. A sensor malfunction is indicated by a continuing flash every four seconds.

If the caution light illuminates, shut off heater and open nose and door vents as required to ventilate the cabin. If hovering, land or transition to forward flight. If symptoms of CO poisoning (headache, drowsiness, dizziness) accompany caution light, land immediately. Have exhaust system inspected before next flight.

Many chemicals can damage the CO sensor. Avoid use of solvents, detergents, or aerosol sprays near the sensor. Temporarily tape off openings in top and bottom of sensor housing when cleaning cabin interior.

EMERGENCY LOCATOR TRANSMITTER (OPTIONAL)

The Emergency Locator Transmitter (ELT) installation consists of a transmitter with internal battery pack, an external antenna, and a remote switch/annunciator. The transmitter is mounted to the upper steel tube frame and is accessible through the aft, upper cowl door. The remote switch/annunciator is located left of the cyclic stick.

The ELT is operated by a switch on the transmitter and a remote switch in the cockpit. The transmitter switch has been secured in the AUTO or ARM position at installation and should always be in this position for flight. The remote switch/annunciator is a three position switch with indicator light. This switch should also be in the AUTO or ARMED (middle) position for flight. With both switches set to AUTO/ARM, the ELT will begin transmitting when subjected to a high "G" load. When the unit is transmitting, the red indicator light illuminates.

Moving the remote switch to ON activates the transmitter. Use the ON position if an emergency landing is imminent and time permits.

If the ELT is inadvertently activated, use the RESET position of the remote switch to stop transmission and reset the unit. The red indicator will extinguish when unit is reset.

NOTE

Earlier aircraft may have ELT installations without remote switch.

For more detailed instructions on ELT operation, maintenance, and required tests, refer to manufacturer's instructions supplied with the unit.

ACCESSORY MOUNTS (OPTIONAL)

Provisions for mounting small, portable items are an option. The provisions use mounting bars located forward of the pilot's seat, the copilot's seat, or both. The bars are fitted with one or more clamp assemblies which are compatible with a variety of commercially available accessory mounts. There is a 10 lb total weight limit for items attached to each bar. USB and cigarette-lighter-style power outlets are installed near the inboard end of the mounting bars. The power outlets are protected by the Aux Power circuit breaker and in-line fuses and are placarded with voltage/current ratings. Wire clamps and a pocket for securing excess wire are also provided.

The accessory mounts are intended to provide a safe means of mounting small items such as portable electronic devices. The mounting bar, clamp assembly, and power outlets are approved as part of the aircraft type design, but any items attached are the responsibility of the pilot in command under appropriate operating rules. Ensure that any items attached are secure and do not interfere with flight controls or primary field of view. Route any wires through the wire clamps or secure them to the bar with cable ties or tape.

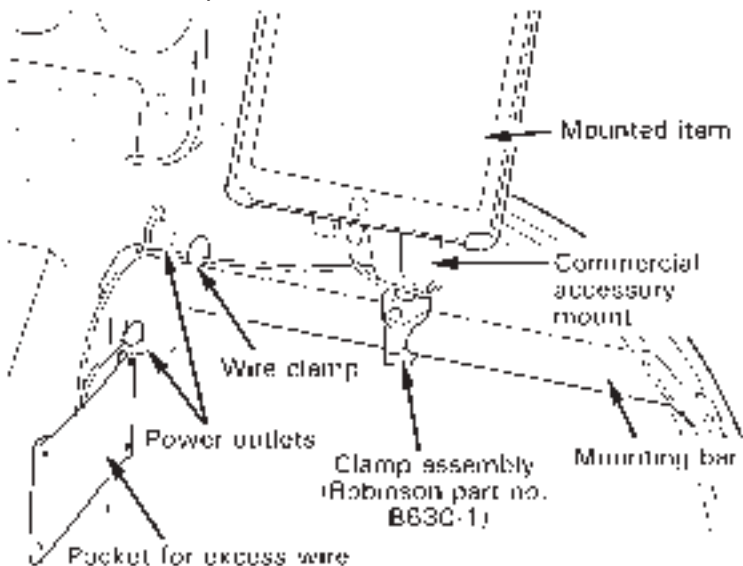

INTENTIONALLY BLANK

**SECTION 8
HANDLING AND MAINTENANCE**

CONTENTS

	Page
General	8-1
Required Documents	8-2
Required Inspections	8-3
Preventive Maintenance by the Pilot	8-4
Alterations to Aircraft	8-5
Ground Handling	8-6
Parking	8-7
Cabin Doors	8-7
Engine Oil	8-8
Gearbox Oil	8-10
Fuel	8-10
Fuel Bladders	8-11
Fire Extinguisher (Optional)	8-11
Battery	8-12
Cleaning Helicopter	8-13

INTENTIONALLY BLANK

SECTION 8

HANDLING AND MAINTENANCE

GENERAL

This section outlines procedures recommended for handling, servicing, and maintaining the R22 helicopter. Every owner should stay in close contact with a Robinson Service Center to obtain the latest service and maintenance information. Owners should also be registered with the factory to receive service bulletins, changes to this handbook, and other helpful information as it becomes available. These publications are available on RHC's website: www.robinsonheli.com

Federal Regulations place responsibility for maintenance of a helicopter on the owner and operator. The owner/operator must insure that all maintenance is performed by qualified mechanics and in accordance with the R22 Maintenance Manual (Instructions for Continued Airworthiness), Service Bulletins/Service Letters, and FAA Airworthiness Directives.

All limits, procedures, safety practices, time limits, servicing, and maintenance requirements contained in this handbook are considered mandatory.

Authorized Robinson Service Centers will have recommended modification, service, and operating procedures issued by the FAA and by Robinson Helicopter Company. This information will be useful in obtaining maximum utility and safety with the helicopter.

REQUIRED DOCUMENTS

The Airworthiness Certificate (FAA Form 8100-2) must be displayed in the aircraft at all times. The following additional documents must be carried in the aircraft:

1. Registration Certificate (FAA Form 8050-3)
2. Pilot's Operating Handbook
3. Current Weight and Balance

The following documents should not be carried in the aircraft, but must be available for use by any mechanic or pilot servicing the aircraft:

1. Aircraft Logbook
2. Engine Logbook

NOTE

Required documents may vary in countries other than the United States.

REQUIRED INSPECTIONS

Federal Regulations require most civil aircraft of U.S. registry to undergo a complete inspection every twelve months. This annual inspection must be signed off by a mechanic with Inspection Authorization (IA). In addition to the annual inspection, the R22 Maintenance Manual requires a complete inspection after every 100 hours of operation.

The R22 helicopter includes many unique features. Without special training, Airframe and Powerplant (A&P) mechanics are not qualified to perform the above inspections. Only appropriately rated personnel who have successfully completed a factory-approved maintenance course, or are under the direct supervision of such personnel, should perform maintenance, repairs, or inspections on the R22 helicopter.

The helicopter incorporates a number of fatigue life-limited components which must be retired at specified time intervals. A list of these components is contained in the Airworthiness Limitations section of the R22 Maintenance Manual and Instructions for Continued Airworthiness.

The factory occasionally publishes Service Bulletins and the Federal Aviation Administration (FAA) occasionally publishes Airworthiness Directives (ADs) that apply to specific groups of aircraft. They are mandatory changes or inspections which must be complied with within the time limit specified. Owners should periodically check with Robinson Service Centers to be sure that the latest Service Bulletins and ADs issued have been complied with.

PREVENTIVE MAINTENANCE BY THE PILOT

14 CFR Part 43 of the Federal Regulations allows a certificated pilot to perform preventive maintenance. Preventive maintenance is defined in the above regulations, and, as applied to the R22 helicopter, includes the following:

1. Replace defective safety wire or cotter pins.
2. Replace bulbs, reflectors, and lenses of position and landing lights.
3. Replace, clean, or gap spark plugs.
4. Clean or replace engine air filter.
5. Change engine oil and filter.
6. Inspect and clean chip detectors.
7. Replenish main and tail gearbox oil.
8. Remove and replace gascolator bowl.
9. Remove or replace cowling or inspection panels.
10. Service or replace battery.
11. Replace wear shoes on landing gear skids.
12. Clean or refinish exterior of aircraft.

Although the above work is allowed by law, it should only be performed by pilots confident that they are qualified to reliably complete the work. All work must be done in accordance with the R22 Maintenance Manual.

After completing the work, when required, the pilot must enter the following in the appropriate logbook:

1. Date work accomplished.
2. Description of work.
3. Total hours on aircraft.
4. Pilot certificate number.
5. Signature of pilot.

ALTERATIONS TO AIRCRAFT

The compactness and many unique design features of the R22 helicopter make any modification inadvisable. The dynamic characteristics and susceptibility to fatigue of the rotor, drive, and control systems make any modification to these systems extremely hazardous.

Also hazardous is installation of any electronic equipment or avionics not factory-approved and supplied. The compactness of the console and tunnel containing the controls and wire bundles makes installation of any additional wires likely to interfere with free control movement. The electronic tachometers and other instruments may be affected by other electrical devices and their reliability and accuracy are essential for safe operation of the helicopter. Installation of unauthorized electrical devices can result in a hazardous condition.

Because of these potential hazards, Robinson Helicopter Company does not authorize any modification or alteration other than those which are factory-supplied and installed by factory-trained personnel.

GROUND HANDLING

For leveling, hoisting, or jacking, see appropriate sections of the maintenance manual.

The helicopter may be maneuvered on the ground using ground handling wheels. Recommended tire pressure is 60 psi (4 bar). Wheels must be removed for flight.

To attach wheels:

1. Hold handle and wheel with protruding spindle in its lowest position.
2. Insert spindle into support mounted on skid. Make sure spindle is all the way in.
3. Pull handle over center to raise helicopter and lock wheel in position.

CAUTION

When lowering helicopter, handle has a tendency to snap over.

Move the helicopter by holding the tail gearbox and aft tailcone section. If additional help is needed, a second person may push on one of the aft vertical frame tubes or on the nose. Alternately, a Robinson electric tow cart may be used per the instructions provided.

CAUTION

Do not move helicopter by gripping vertical stabilizers, outboard part of horizontal stabilizer, tail rotor, tail skid, or tail rotor controls.

PARKING

1. Place cyclic control in neutral position and apply friction.
2. Put collective full down and apply friction.
3. Align rotor blades approximately fore and aft. Apply rotor brake. Use blade tie-downs in windy conditions.

CAUTION

If using rotor blade tie-downs, do not overtighten tie-down straps (5 lb max tension). Do not pull down on blades to teeter rotor. To lower a blade, push up on opposite blade.

4. During storm conditions, helicopter should be hangared or moved to a safe area.
5. If helicopter is hangared, turn fuel shutoff valve off.

CABIN DOORS

Both cabin doors may be removed and installed by maintenance personnel or pilots. To remove a door, remove cotter pins in upper and lower hinge pins, then open and lift door off. To install doors, use reverse procedure. Adjust weight and balance as required when removing and installing doors.

ENGINE OIL

Recommended maximum oil quantity is six quarts and minimum quantity for takeoff is four quarts as indicated on the oil dipstick.

The oil and filter should be changed at least every 50 hours or four months, whichever occurs first. If no oil filter is installed, change oil every 25 hours.

To change oil:

1. Ground run or fly helicopter to obtain normal operating temperature.
2. Remove left side skirts. If heater blower is installed, disconnect heater hose and blower motor ground wire and remove bolt securing blower motor to frame. Open quick drain on bottom of sump to drain oil into suitable container.
3. Cut safety wire from oil suction-screen cap located near centerline at accessory (magneto) end of sump. (Located on bottom of sump for O-320 engines.)
4. Remove, inspect, clean, and reinstall oil suction screen. Re-safety cap.
5. Cut safety wire (if installed) from oil filter and break loose using wrench or loosen pressure-screen housing bolts.
6. Place suitable container below and inboard of magneto to catch oil retained in filter or screen housing and remove filter or screen housing slowly to allow oil to drain into container. Do not allow oil to drain on magneto housing.
7. Cut filter open to inspect, or inspect and clean pressure screen.

ENGINE OIL (cont'd)

8. Install new filter per instructions printed on filter. Use only Champion CH48108, CH48108-1, Tempest AA48108-2, or Robinson B123-1 or -2 filter. Safety wire is not required on filter. Re-install pressure screen and housing. Torque pressure-screen housing bolts to 96 in.-lb.
9. Close quick drain and fill sump with 6 quarts of appropriate grade oil as recommended below.
10. Start helicopter. Verify oil pressure within 30 seconds. Ground run for a few minutes, shut down, and verify no leaks.
11. Check oil level on dipstick.
12. Reinstall side skirts. Reinstall heater blower motor and heater hose, as required.
13. Make appropriate maintenance record entries.

The following grades of oil are recommended:

Average Ambient Air Temperature	Mineral Grades MIL-L-6082 or SAEJ1966 (Use first 50 hours)	Ashless Dispersant Grades MIL-L-22851 or SAEJ1899 (Use after first 50 hours)
All Temperatures	—	SAE15W50 or SAE20W50
Above 60°F	SAE50	SAE40 or SAE50
30°F to 90°F	SAE40	SAE40
0°F to 70°F	SAE30	SAE30, SAE40, or SAE20W40
0°F to 90°F	SAE20W50	SAE20W50 or SAE15W50
Below 10°F	SAE20	SAE30 or SAE20W30

GEARBOX OIL

Main and tail gearbox oil quantities are indicated by sight gages. The main gearbox sight gage is on the right side of the gearbox and can be viewed by opening the cowl door below the aux fuel tank. The tail gearbox sight gage is located at the aft end of the tail gearbox.

If oil is not visible in the sight gage with helicopter sitting level, oil must be added. The gearboxes use either Robinson P/N A257-2 or A257-22 oil. Refer to placard to ensure correct oil is being added.

To add oil to the tail gearbox:

1. Cut safety wire (if installed) and remove filler/vent cap located on top of gearbox.
2. Fill very slowly to center of sight gage. DO NOT overfill. (Less than a teaspoon of oil is usually required.)
3. Reinstall filler/vent cap. Be sure metal gasket or rubber o-ring is in place. Torque to 100 in.-lb.
4. Safety wire as before. (Safety wire not required if cap is sealed with an o-ring.) Be sure safety wire applies tension in direction which would tighten cap.

To add oil to the main gearbox, see maintenance manual.

FUEL

Approved fuel grades and fuel capacity are given in Section 2.

A small quantity of fuel should be drained from the gascolator and from each tank using the quick drains prior to the first flight of the day and after refueling. On later helicopters, a glass tube stowed inside the upper, aft cowl door is provided which may be used to catch the fuel samples. Drain enough fuel to remove any water or dirt and check for approved fuel color. If fuel contamination is suspected, continue to drain fuel from gascolator and tank drains until all contamination is eliminated.

FUEL BLADDERS

Fuel tanks may be equipped with crash-resistant flexible bladders. The bladders are subject to deterioration, which may cause them to leak or seep fuel as they age. To prolong bladder life, fuel tanks should be topped off when the helicopter is stowed to keep the bladder material from drying out. Extreme heat and water adversely affect the material. Therefore, ensure the sumps are drained of water and use a hangar for stowage when possible.

FIRE EXTINGUISHER (OPTIONAL)

The optional fire extinguisher (model RT-A400) should be weighed monthly to verify it contains a sufficient charge of extinguishing agent. Results should be recorded on the decal affixed to the extinguisher or in other maintenance records. If weight falls below 500 grams, remove extinguisher from service.

The extinguisher is rated for a storage and operating temperature of 120°F (49°C). If operating conditions would expose extinguisher to higher temperatures (e.g. parking in the sun in a hot climate), remove extinguisher and store it in a cooler area between flights.

BATTERY

The 12-volt battery is located either in the engine compartment or beneath the instrument console. The battery is sealed and does not require fluid level checks.

A discharged battery is NOT AIRWORTHY because it will not have the reserve capacity to operate the electrical system should the charging system fail in flight.

Often, a 10 or 15 minute charge will improve battery condition enough to start the engine. If battery is located in the engine compartment, first connect positive charger cable to positive (battery side) battery relay terminal. Then, connect negative charger cable to battery ground strap or engine. If battery is located beneath the instrument console, remove console hold down screws (one each side), lift console, remove battery box cover, and connect charger cables directly to battery posts (connect positive cable first). Use extreme caution not to short to console sheet metal.

After charging, disconnect cables (disconnect negative cable first), secure console if opened, and attempt a normal start. If battery still has insufficient charge to start engine, service or replace battery before further flight.

CLEANING HELICOPTER

CLEANING EXTERIOR INCLUDING ROTOR BLADES

The helicopter should be washed with mild soap and water. Harsh abrasives, alkaline soaps, or detergents should not be used because they could scratch painted or plastic surfaces or could cause corrosion of metal. Cover areas where cleaning solution could cause damage. Use the following procedure:

1. Rinse away loose dirt and salt residue with water.
2. Apply cleaning solution with a soft cloth, sponge, or soft bristle brush.
3. To remove stubborn oil and grease, use a cloth dampened with aliphatic naphtha.
4. Rinse all surfaces thoroughly.
5. Apply carnauba wax to rotor blades and renew wax when water no longer beads on blade surface. Any good automotive wax may be used to preserve other painted surfaces. Soft cleaning cloths or a chamois should be used to prevent scratches when cleaning or polishing.

CAUTION

Never use high-pressure spray to clean helicopter. Never blow compressed air into main or tail rotor blade tip drain holes.

CLEANING WINDSHIELD AND WINDOWS

1. Remove dirt, mud, and other loose particles from exterior surfaces with clean water.
2. Wash with mild soap and warm water or with aircraft plastic cleaner. Use a soft cloth or sponge in a straight back and forth motion. Do not rub harshly.
3. Remove oil and grease with a cloth moistened with isopropyl alcohol (rubbing alcohol) or aliphatic naphtha.

CLEANING HELICOPTER (cont'd)

CLEANING WINDSHIELD AND WINDOWS (cont'd)

CAUTION

Do not use gasoline, other alcohols, benzene, carbon tetrachloride, thinner, acetone, or window (glass) cleaning sprays.

4. After cleaning plastic surfaces, apply a thin coat of hard polishing wax. Rub lightly with a soft cloth. Do not use a circular motion.
5. Scratches can be removed by rubbing with jeweler's rouge followed by hand polishing with commercial plastic polish. Use a figure eight motion when polishing.

CLEANING UPHOLSTERY AND SEATS

1. Vacuum and brush, then wipe with damp cloth. Dry immediately.
2. Soiled upholstery, except leather, may be cleaned with a good upholstery cleaner suitable for the material. Follow manufacturer's instructions. Avoid soaking or harsh rubbing.

CAUTION

If CO detector is installed, avoid use of solvents, detergents, or aerosol sprays near sensor. Tape off openings in top and bottom of sensor housing when cleaning cabin interior.

3. Leather should be cleaned with saddle soap or a mild hard soap and water.

CLEANING CARPETS

Remove loose dirt with a whisk broom or vacuum. For soiled spots and stains, use nonflammable dry cleaning liquid.

**SECTION 9
SUPPLEMENTS**

OPTIONAL EQUIPMENT SUPPLEMENTS

Information contained in the following supplements applies only when the related equipment is installed.

CONTENTS

	Page
Police Version	9-3.1
Mariner/Mariner II	9-4.1
ADS-B Equipment	9-9.1
Optional Avionics	9-10.1

NON-U.S. SUPPLEMENTS

The following supplements contain additional information required by certain countries:

- Brazilian Supplement
- FATA Supplement (Russia)
- IAC AR Supplement
- Ukrainian Supplement

INTENTIONALLY BLANK

FAA APPROVED
R22 PILOT'S OPERATING HANDBOOK
SUPPLEMENT 3
TO
ROBINSON MODEL R22

This supplement must be attached to the FAA Approved Robinson R22 Pilot's Operating Handbook when the helicopter is configured with optional police version equipment.

The information contained herein supplements or supersedes the basic manual only in those areas listed in this Supplement. For limitations, procedures, and performance information not contained in this Supplement, consult the basic R22 Pilot's Operating Handbook.

FAA APPROVED *James H. Hughes*
Supervisor, Flight Test Section
FAA, Western Aircraft Certification Field Office
Northwest Mountain Region

DATE *March 27, 1994*

LOG OF REVISIONS	
Page No.	Approval Date
9-3.1	04 Nov 1994
9-3.2	18 Dec 1987
9-3.3	04 Nov 1994
9-3.4	04 Nov 1994
9-3.5	04 Nov 1994
9-3.6	04 Nov 1994

REVISIONS
APPROVED BY *Donald Austin*
Manager, Flight Test Branch ANM-160L
Federal Aviation Administration, LAACO
Transport Airplane Directorate

DATE *Nov. 9, 1994*

SECTION 9
R22

POLICE VERSION

INTRODUCTION

This supplement contains the changes and additional data applicable when the R22 helicopter is equipped with Police Version options.

SECTION 2: Limitations

VFR operation at night is permitted with either landing lights or searchlight operable. Instrument and anti-collision lights must be installed and operable.

SECTION 3: Emergency Procedures

No change.

SECTION 4: Normal Procedures

Additions to preflight check.

Add to number 10, fuselage left side.
PA Speaker secure
Searchlight secure

SECTION 5: Performance

No change.

SECTION 6: Weight & Balance

No change.

SECTION 7: Systems Description

The following optional equipment may be installed:

Airframe

Cabin doors with bubble windows to enhance downward and rearward visibility replace the standard doors.

Electrical System

A 14-volt, 70-ampere alternator replaces the standard 60-ampere unit.

Searchlight Installation

The searchlight installation consists of two lamps suspended below the cabin chin on a post which extends through the left hand side of the chin and cabin floor. The searchlight is controlled by means of a grip and switch(es) mounted on the post allowing operation by the passenger or pilot. Power is supplied to the searchlight through its own 20 amp circuit breaker and power relay. The searchlight will operate only when the landing lights are off. A friction control is located on the post just above the floor.

Two searchlight installations are available: one manufactured by Collins Dynamics and the other by Peak Beam Systems. The Collins Dynamics unit uses incandescent quartz halogen lamps controlled by a single on-off toggle switch on the grip. The Peak Beam Systems unit uses xenon arc lamps controlled by four momentary toggle switches on the grip. These switches control on-off, strobe (rapidly flashing) mode, and beam spread from 1° spot to 40° flood.

CAUTION

When operating the searchlight with the left seat cyclic installed, caution should be exercised to prevent interference with the cyclic control.

SECTION 7: Systems Description (Cont'd)

PA System

A 100-watt Whelen PA speaker and siren is located on the aft, left landing gear strut. The PA system control panel is located on the instrument panel. It allows the pilot or observer to select either PA, radio, yelp, or siren for broadcast through the PA speaker.

Remote Radio Transmit Switch

A hand-held remote radio transmit switch plugs into the receptacle on the front of the left seat. This switch allows the left seat occupant to transmit when the left cyclic is removed.

Circuit Breaker Panel

The circuit breaker panel is shown in Figure 1.

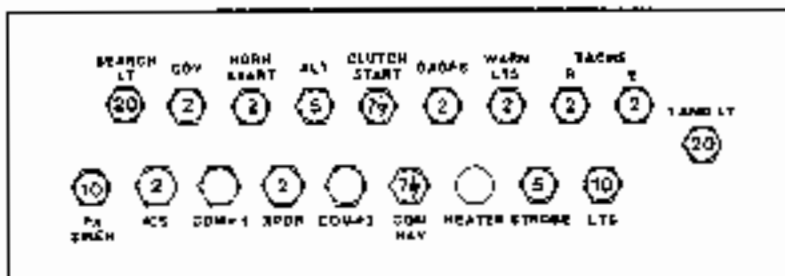

FIGURE 1
CIRCUIT BREAKER PANEL

SECTION 8: Handling and Maintenance

Searchlight Installation

To remove the searchlight from the helicopter, use the following procedure:

1. Loosen but do not remove two 1/4 in. diameter bolts in clamp on bottom end of post.
2. Remove clevis pin connecting lower end of tube through center of post to arms between lamps.
3. Disconnect wires from lamps at connectors on lamp housings.
4. Pull ring on spring loaded pin in post clamp and slide clamp with lamps off post.
5. Remove four screws holding post flange to cabin floor. Pull post up a few inches and disconnect wires at post connector. Before releasing, o-ring around the connector must be moved clear of retaining hooks. Pull post up and out of floor.
6. Cover connector under floor with tape and install sheet metal cover provided over hole in floor.

Installation is the reverse except:

1. Be sure to position o-ring on post wire connector under retaining hooks.
2. The letters 'FWD' on post flange must face forward.
3. Be sure spring loaded pin in post clamp pops into place and torque 1/4 in. diameter bolts to 90 in.-lb (includes nut self-locking torque).

THIS PAGE INTENTIONALLY LEFT BLANK.

FAA APPROVED
 R22 PILOT'S OPERATING HANDBOOK

SUPPLEMENT 4
 R22 MARINER/MARINER II

This supplement must be attached to the FAA Approved Robinson R22 Pilot's Operating Handbook when the helicopter is configured in the Mariner or Mariner II version.

The information contained herein supplements or supersedes the basic manual only in those areas listed in this Supplement. For limitations, procedures, and performance information not contained in this Supplement, consult the basic R22 Pilot's Operating Handbook.

FAA APPROVED *Frank J. Hoffman*
 Supervisor, Flight Test Section
 FAA, Western Aircraft Certification Office
 Northwest Mountain Region

DATE *Sept. 9, 1985*

LOG OF REVISIONS

Page No.	Date	Page No.	Date
9-4.1	13 Oct 00	9-4.8	13 Oct 00
9-4.2	13 Oct 00	9-4.9	13 Oct 00
9-4.3	13 Oct 00	9-4.10	13 Oct 00
9-4.4	13 Oct 00	9-4.11	13 Oct 00
9-4.5	13 Oct 00	9-4.12	13 Oct 00
9-4.6	13 Oct 00	9-4.13	13 Oct 00
9-4.7	13 Oct 00		

REVISIONS
 APPROVED BY *Donald C. ...*
 Manager, Flight Test Branch, ANM-160L
 Federal Aviation Administration, LAACD
 Transport Airplane Directorate

DATE *Oct. 13, 2000*

SECTION 1: GENERAL

INTRODUCTION

This supplement contains the changes and additional data applicable for R22 Mariner and Mariner II helicopters. R22 Mariner/Mariner II helicopters are equipped with either float or standard landing gear, additional corrosion protection, and a modified horizontal stabilizer angle of incidence. Except as noted in this supplement, information in the basic manual pertaining to the R22 Beta is applicable to the R22 Mariner and information pertaining to the Beta II is applicable to the Mariner II.

Float landing gear consists of inflated floats attached to the skid tubes, and skid extensions to support the aft portion of the float tubes. When float landing gear is installed, an additional stabilizer is installed at the bottom of the lower vertical stabilizer for improved controllability. Configuration changes between float and standard landing gear are permitted.

SECTION 2: LIMITATIONS

AIRSPPEED LIMITATIONS

NEVER EXCEED AIRSPEED (V_{ne}) WITH FLOATS

Power-On: 95 KIAS up to 3000 ft density altitude.

Power-Off: 80 KIAS up to 7500 ft density altitude.

Above these density altitudes, see placard on page 9-4.4.

CENTER OF GRAVITY (CG) LIMITS

See figure on page 9-4.3. Datum line is 100 inches forward of main rotor shaft centerline.

KINDS OF OPERATION LIMITATIONS

Only VFR day is approved when floats are installed.

SECTION 2: LIMITATIONS (cont'd)

WITH FLOATS _____

WITHOUT FLOATS - - - - -

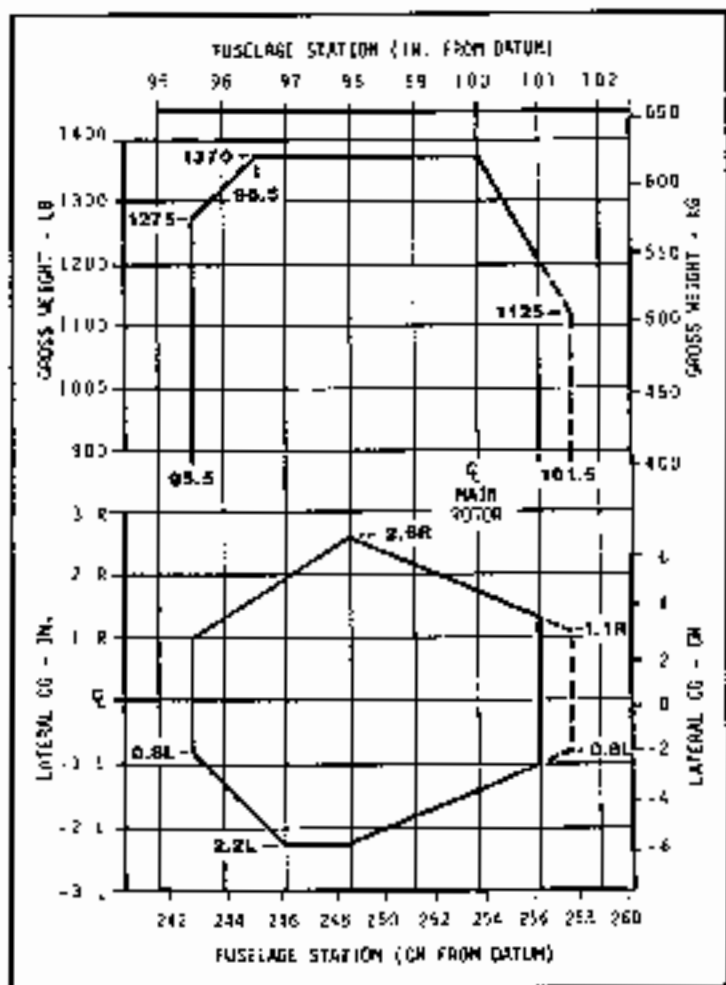

R22 MARINER/MARINER II
 CENTER OF GRAVITY LIMITS

SECTION 2: LIMITATIONS (cont'd)

PLACARDS

In clear view of pilot:

THIS ROTORCRAFT IS APPROVED FOR
DAY AND NIGHT VFR OPERATIONS
WITHOUT FLOATS INSTALLED
OR
DAY VFR OPERATIONS ONLY
WITH FLOATS INSTALLED

In clear view of pilot in flight:

R22 Mariner

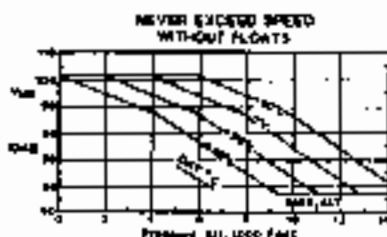
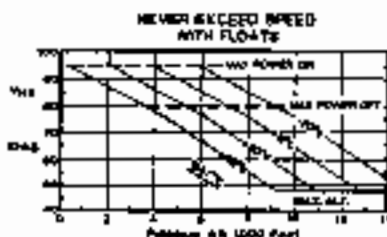

R22 Mariner II

NEVER EXCEED SPEED - KIAS
WITH FLOATS

PRESS ALT. FT.	OAT °C						
SL	20	10	0	10	20	30	40
2000	95						
4000	94						
6000	91						
8000	96	82	77	72	67	62	57
10000	77	72	66	61	56	51	
12000	56	48	38	NO FLIGHT			
14000	54	NO FLIGHT					

FOR AUTOGYRATION, USE 90 KIAS ABOVE HEAVY LINE

NEVER EXCEED SPEED - KIAS
WITHOUT FLOATS

PRESS ALT. FT.	OAT °C						
SL	20	10	0	10	20	30	40
2000	102						
4000	102						
6000	99						
8000	94	90	84	80	74	68	62
10000	76	68	58	54	48	42	36
12000	54	47	37	NO FLIGHT			
14000	51	NO FLIGHT					

Located on floats:

SEE PILOT'S HANDBOOK FOR
PROPER INFLATION PRESSURE

SECTION 2: LIMITATIONS (cont'd)

FLOAT PRESSURE LIMITS

Minimum Float Pressure: 2 psig (psi gage)

Maximum Float Pressure: 6 psig

The following graph shows minimum float pressure required for a decrease in altitude or temperature. An increase in either altitude or temperature can be ignored as pressure relief valves will limit pressure to 6 psig.

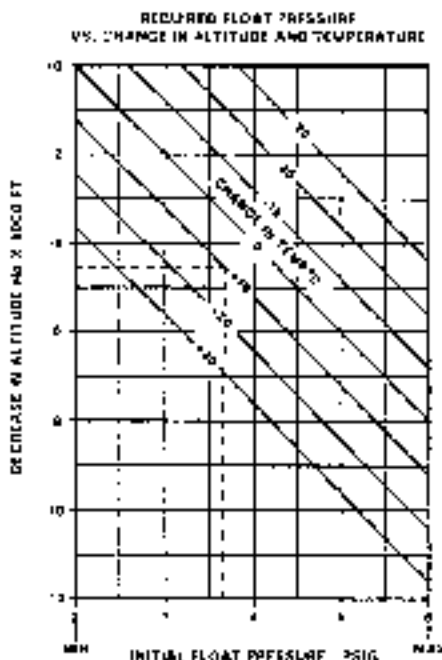

CAUTION

Failure to maintain required pressure can result in inadequate buoyancy or in-flight instability.

SAMPLE CALCULATION:

	<u>Pressure</u>	<u>Altitude</u>	<u>Temp</u>
Conditions at destination:	1000 ft	15°C	
Initial Conditions:	5500 ft	5°C	
Subtract to obtain expected change in altitude and temp:	-4500 ft	+10°C	

Using graph, locate -4500 ft line, read across to +10°C line, then down for minimum initial float pressure required, approximately 3.7 psig.

SECTION 3: EMERGENCY PROCEDURES

GENERAL

Without floats, emergency procedures in the basic manual apply. The following procedures are applicable when floats are installed.

POWER FAILURE ABOVE 500 FEET AGL

Autorotation to Land: Same as non-float R22.

Autorotation to Water: Steps 1-7 same as non-float R22.

8. At about 8 feet AGL, apply forward cyclic to level helicopter and raise collective just before touchdown to cushion landing. Touchdown in slight nose high attitude with nose straight ahead.
9. Maintain cyclic in touchdown position and hold collective up until forward motion has stopped. See caution below.

POWER FAILURE BETWEEN 50 AND 500 FEET AGL

Autorotation to Land: Same as non-float R22.

Autorotation to Water: Steps 1-4 same as non-float R22.

5. At about 8 feet AGL, apply forward cyclic to level helicopter and raise collective just before touchdown to cushion landing. Touchdown in slight nose high attitude with nose straight ahead.
6. Maintain cyclic in touchdown position and hold collective up until forward motion has stopped.

CAUTION

Lowering collective or applying forward cyclic while helicopter is moving forward on water can cause floats to submerge and helicopter to nose over.

DITCHING

Not applicable when floats are installed.

SECTION 4: NORMAL PROCEDURES

DAILY OR PREFLIGHT CHECKS

14. Inflatable Floats

- Float Pressure Check (See Section 2)
- Float Condition Check

CAUTION

Helicopters equipped with inflated floats have an adverse roll characteristic; when sideslipping nose left or right the helicopter will tend to roll in the opposite direction. To avoid adverse roll, keep helicopter trimmed with zero sideslip and exercise extreme caution when performing simulated power failures.

OPERATION ON WATER

Maximum recommended water taxi speed is 5 knots. Some application of collective is required.

CAUTION

If starting or stopping rotor on water, ensure area is clear as helicopter can rotate one complete turn while tail rotor RPM is low.

CAUTION

To avoid contacting rotor teeter stops, do not apply full cyclic control during water taxi.

NOTE

Safe operation on water has been demonstrated in waves up to 12 inches (trough to crest).

SECTION 4: NORMAL PROCEDURES (cont'd)

PRACTICE AUTOROTATION - WITH GROUND CONTACT

Same as non-float R22 except rear of floats may be scuffed on pavement during touchdown. Protective tape should be applied to bottom of floats and inspected for wear after touchdowns.

PRACTICE AUTOROTATION - WITH WATER CONTACT

Same as practice autorotation with ground contact in basic manual except touch down in slight nose high attitude with nose straight ahead. Maintain cyclic in touchdown position and collective up until forward motion has stopped.

CAUTION

Lowering collective or applying forward cyclic while helicopter is moving forward on water can cause floats to submerge and helicopter to nose over.

SECTION 5: PERFORMANCE

HOVER PERFORMANCE

In-ground-effect (IGE) and out-of-ground-effect (OGE) hover performance charts for the R22 Mariner are on pages 9-4.9 and 9-4.10.

R22 Mariner II hover performance is equivalent to R22 Beta II hover performance.

IN GROUND EFFECT AT 2 FOOT SKID CLEARANCE
 FULL THROTTLE AND 104% RPM

GROSS WEIGHT - KG

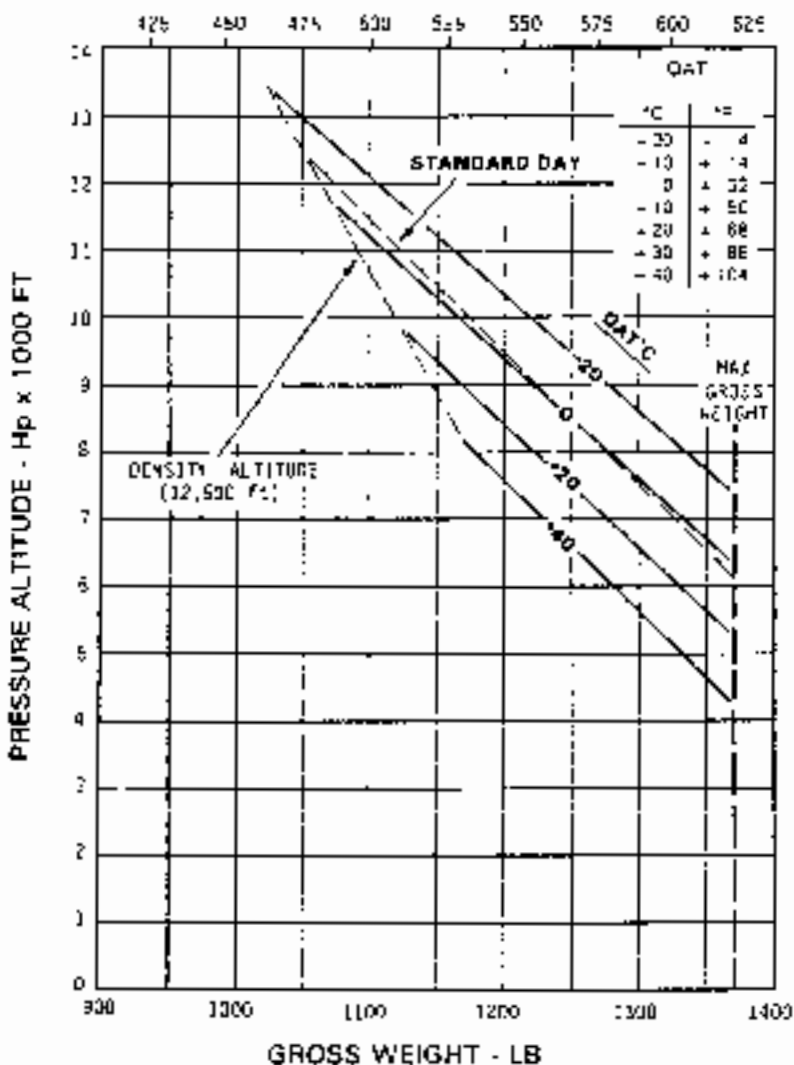

R22 MARINER
 O-320-B2C Engine
 IGE HOVER CEILING VS. GROSS WEIGHT

OUT OF GROUND EFFECT
TAKEOFF POWER OR FULL THROTTLE AT 104% RPM

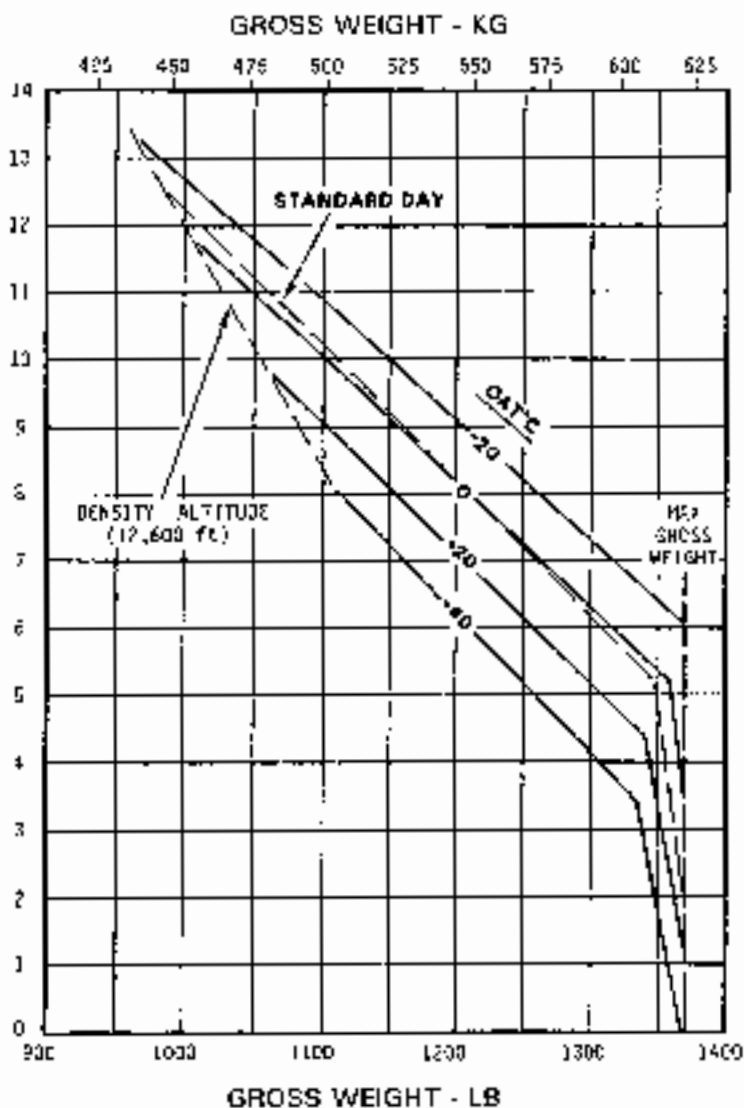

R22 MARINER
O-320-B2C Engine
5 Minute Takeoff Rating
OGE HOVER CEILING VS. GROSS WEIGHT

SECTION 6: WEIGHT AND BALANCE

CAUTION

When changing from float-equipped to non-float configuration or vice versa, weight and balance for basic helicopter must be revised and autorotation RPM readjusted per R22 Maintenance Manual

WEIGHT AND BALANCE RECORD

Basic empty weight and CG in float and non-float configurations is included in the Weight and Balance Data provided with the helicopter. Modifications are to be recorded on page 6-5 of the basic manual.

LOADING INSTRUCTIONS

Determine loaded helicopter weights and moments per page 6-7. These values must fall within the Weight and Moment envelope shown below.

WITHOUT FLOATS WITH FLOATS

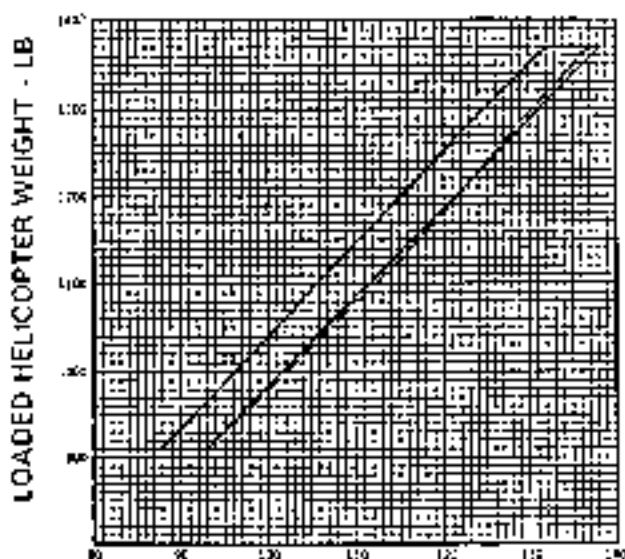

LOADED HELICOPTER MOMENT - 1000 inch-lbs.

R22 MARINER/MARINER II

Allowable CG Moment vs. Gross Weight Envelope

SECTION 7: SYSTEMS DESCRIPTION No change.

SECTION 8: HANDLING, SERVICING AND MAINTENANCE

GROUND HANDLING

When floats are installed, special ground handling wheels are required. Refer to the R22 Maintenance Manual for wheel installation and removal procedures.

FLOAT TUBES

To promote long float tube life:

1. Do not inflate floats to a higher pressure than required in the Limitations section.
2. Do not arbitrarily inflate floats to the relief valve pressure.
3. Reduce pressure in floats if solar heating is causing an excessive pressure buildup.
4. Do not allow floats to sit uninflated for long periods of time, always maintain some pressure to keep shape when not in use.

CAUTION

When inflating chambers individually (without the use of a manifold), increase pressure in each chamber in 0.5 psig increments.

SECTION 10: SAFETY TIPS

Flight characteristics and handling qualities of a helicopter with inflated floats are more critical than those for helicopters with conventional landing gear. For instance, helicopters with floats installed have an adverse roll characteristic, i.e. when sideslipping nose right or left, the helicopter will tend to roll in the opposite direction out of the turn. This could be extremely dangerous if a student or instructor failed to put in right pedal or put in the wrong pedal during a simulated power failure. Also, aerodynamic lift produced by the floats makes both RPM and longitudinal attitude control more difficult during autorotation entries. Helicopters with floats installed are also more gust sensitive and therefore more difficult to fly in turbulence.

For these reasons, it is strongly recommended that floats be removed and standard gear installed when the helicopter is being used for primary flight instruction. When floats are installed, pilots must keep the helicopter trimmed with zero sideslip and exercise extreme caution when performing simulated power failures.

INTENTIONALLY BLANK

**FAA APPROVED
R22 PILOT'S OPERATING HANDBOOK
ADS-B EQUIPMENT SUPPLEMENT**

This supplement must be included in the FAA-approved Pilot's Operating Handbook when ADS-B equipment is installed.

The information contained herein supplements or supersedes the basic manual only in those areas listed in this supplement. For limitations, procedures, and performance information not contained in this supplement, consult the basic Pilot's Operating Handbook.

APPROVED BY: 
Manager, Flight Test Branch, ANM-160L
Federal Aviation Administration, LAACO
Transport Airplane Directorate

DATE: February 21, 2014

LOG OF REVISIONS

Page No.	Date	Page No.	Date
9-9.1	26 Oct 16	9-9.4	26 Oct 16
9-9.2*	26 Oct 16	9-9.5	26 Oct 16
9-9.3*	26 Oct 16	9-9.6*	26 Oct 16

* Manufacturer's data, not FAA approved.

REVISIONS
APPROVED BY: 
Manager, Flight Test Branch, ANM-160L
Federal Aviation Administration, LAACO
Transport Airplane Directorate

DATE: October 26, 2016

SECTION 1: GENERAL

INTRODUCTION

This supplement contains the changes and additional data applicable when Automatic Dependent Surveillance-Broadcast (ADS-B) equipment is installed.

ADS-B is divided into two categories – ADS-B “Out” and ADS-B “In”.

ADS-B Out equipment transmits information to air traffic control to supplement radar/transponder information. The supplemental information allows optimization of flight plan routes and aircraft spacing.

ADS-B Out equipment may be required for operation in certain airspace. The R22 ADS-B Out installation has been shown to meet the requirements of 14 CFR § 91.227.

NOTE

The R22 ADS-B Out system operates on frequency 1090 MHz. This frequency is also accepted for ADS-B Out equipment in most countries outside the United States.

The ADS-B Out equipment consists of either a GPS receiver connected to the transponder or a transponder with built in GPS. The transponder has ADS-B broadcast capability and broadcasts GPS position as well as additional pre-programmed information such as aircraft identification and type to air traffic control.

ADS-B In equipment receives traffic information from other ADS-B equipped aircraft. ADS-B In equipment may also receive additional traffic information and weather information from ground stations. The additional traffic and weather information from ground stations is only available in the United States.

SECTION 1: GENERAL (cont'd)

INTRODUCTION (cont'd)

The ADS-B In equipment consists of a receiver built in to the transponder and a suitable display. Refer to receiver and display manufacturers documentation for operation of ADS-B In equipment.

The R22 may be equipped with only ADS-B Out or with both ADS-B Out and ADS-B In.

SECTION 2: LIMITATIONS

PLACARDS

On transponder when ADS-B Out equipment is installed:

ADS-B OUT INSTALLED

SECTION 3: EMERGENCY PROCEDURES No change.

SECTION 4: NORMAL PROCEDURES

ADS-B SYSTEM OPERATION

ADS-B system operation is mostly automatic and requires little pilot action. The GPS (if separate from the transponder), transponder, and display (if installed) must all be powered and in normal operating modes for proper system function.

ADS-B OUT

The R22 ADS-B Out system is a single point of entry system. Mode 3/A codes, IDENT commands, and emergency codes are set on the transponder and are automatically incorporated in ADS-B Out broadcasts. The transponder should transition to ALT mode after takeoff for proper ADS-B Out broadcasts.

ADS-B Out broadcasts may be selected off by using menus associated with the transponder FUNC key.

NOTE

ADS-B Out may be required in certain airspace. Do not turn off ADS-B Out unless directed by air traffic control.

Malfunctions in the ADS-B Out system are annunciated by various messages on the transponder or display (refer to manufacturers' documentation).

SECTION 4: NORMAL PROCEDURES (cont'd)

ADS-B SYSTEM OPERATION (cont'd)

ADS-B IN

ADS-B In receiver is built in to the transponder and has no direct pilot interface.

ADS-B In data is sent from the receiver to a suitable display, often the primary GPS screen. The display may have dedicated traffic and weather views or may allow traffic and weather information to be overlaid on other data such as moving maps. Warnings such as traffic conflicts may also appear on the display. Refer to receiver and display manufacturers' documentation.

SECTION 5: PERFORMANCE

No change.

SECTION 6: WEIGHT AND BALANCE

No change.

SECTION 7: SYSTEM DESCRIPTION

ADS-B SYSTEM

The ADS-B Out system consists of either a GPS receiver connected to the transponder or a transponder with built-in GPS. The transponder broadcasts the aircraft's position, identification, and certain other parameters to air traffic control. ADS-B data is broadcast via the Extended Squitter (ES) feature of the transponder on a frequency of 1090 MHz. Note that change of aircraft registration may require update of preprogrammed parameters by qualified maintenance personnel.

Most of the data required for ADS-B broadcast such as aircraft type, ICAO address, and call sign are pre-programmed at installation. Flight-specific data such as Mode 3/A code and IDENT are entered using the transponder controls. The transponder uses these codes simultaneously for standard transponder as well as ADS-B broadcasts. There is no need to make a second code entry or to enter a code more than once. This is known as a "single point of entry" ADS-B system.

The ADS-B In system consists of a receiver built in to the transponder and a suitable display. The receiver receives both approved US ADS-B Frequencies (978 MHz and 1090 MHz).

SECTION 8: HANDLING, SERVICING AND MAINTENANCE

No change.

**FAA APPROVED
R22 PILOT'S OPERATING HANDBOOK
OPTIONAL AVIONICS SUPPLEMENT**

This supplement must be included in the FAA-approved Pilot's Operating Handbook when certain factory-supplied optional avionics are installed.

Information contained herein supplements or supersedes the basic manual only in those areas listed in this supplement. For limitations, procedures, and performance information not contained in this supplement, consult the basic Pilot's Operating Handbook.

APPROVED BY: **Nevada Jo Ryan** Digitally signed by Nevada Jo Ryan
Date: 2019.06.20 10:08:15 -07'00'
Manager, West Flight Test Section, AIR-716
Federal Aviation Administration
Los Angeles, CA

DATE: 20 JUN 2019

LOG OF PAGES

Page No.	Date	Page No.	Date
9-10.1	20 JUN 19	9-10.4*	20 JUN 19
9-10.2*	20 JUN 19	9-10.5*	20 JUN 19
9-10.3	20 JUN 19		

* Manufacturer's data, not FAA approved.

SECTION 1: GENERAL

INTRODUCTION

This supplement provides additional information for certain avionics options. A set of manufacturers' instructions for all installed avionics is provided with each new helicopter.

The following equipment is addressed in this supplement:

- Aspen Avionics EFD 1000H PFD

NOTE

For the Robinson Primary Flight Display (PFD) installation, the airspeed indicator, altimeter, compass, tachometer, and engine instruments are retained. Pilots should use the traditional instruments as primary unless fully familiar with the installed avionics.

SECTION 2: LIMITATIONS	No change.
SECTION 3: EMERGENCY PROCEDURES	No change.
SECTION 4: NORMAL PROCEDURES	No change.
SECTION 5: PERFORMANCE	No change.
SECTION 6: WEIGHT AND BALANCE	No change.
SECTION 7: SYSTEMS DESCRIPTION	See below.
SECTION 8: HANDLING AND MAINTENANCE	
No change.	

SECTION 7: SYSTEMS DESCRIPTION

ASPEN EFD 1000H PFD

The Aspen Electronic Flight Display (EFD) 1000H is a Primary Flight Display (PFD) optimized for helicopter use. It is available in a "Pilot" (basic) version or "Pro" (with more advanced navigation features) version.

A typical instrument panel is illustrated on the following page.

The manufacturer's document for the EFD 1000H is:

Title	Document No.
<i>Aspen Avionics Evolution Flight Display EFD 1000H PFD Pilot's Guide</i>	091-00012-001

NOTE

A Robinson part no. D327-4 light filter may be used to reduce reflections in the windshield at night. The light filter is installed by clipping it to the front of the display. Filter use is at pilot discretion.

SECTION 7: SYSTEMS DESCRIPTION (cont'd)

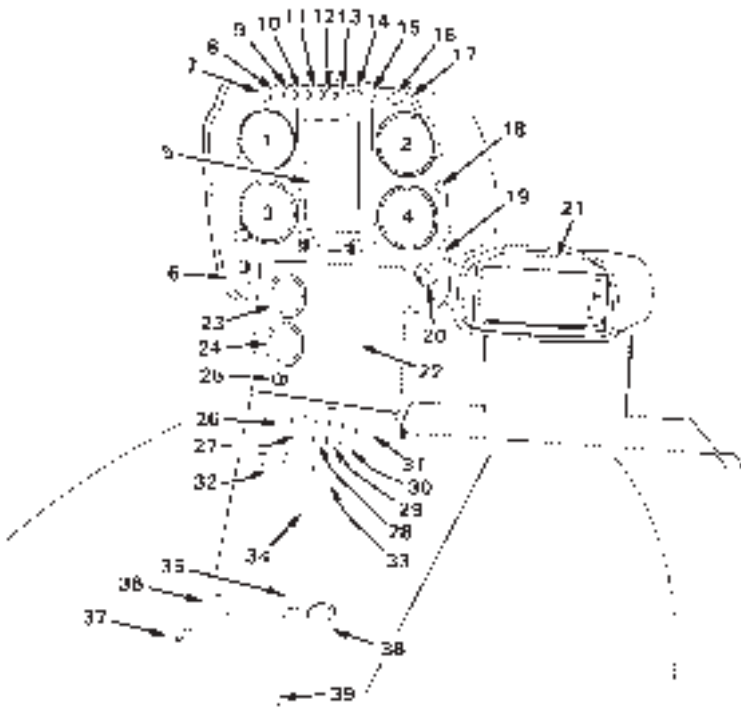

- | | |
|-----------------------------|----------------------------------|
| 1. VERTICAL SPEED INDICATOR | 21. PILOT'S SIDE CONSOLE (OPT'L) |
| 2. ENGINE AND ROTOR TACHS | 22. ENGINE INSTRUMENTS |
| 3. ALTIMETER | 23. CARBURETOR AIR TEMP |
| 4. MANIFOLD PRESSURE GAGE | 24. CLOCK |
| 5. PRIMARY FLIGHT DISPLAY | 25. PANEL LIGHTS DIMMER |
| 6. CLUTCH ACTUATOR SWITCH | 26. NAVIGATION LIGHTS SWITCH |
| 7. CLUTCH ACTUATOR LIGHT | 27. ANTI-COLLISION LIGHT SWITCH |
| 8. M.R. GEARBOX TEMP LIGHT | 28. AVIONICS MASTER SWITCH |
| 9. M.R. GEARBOX CHIP LIGHT | 29. ALTERNATOR SWITCH |
| 10. CARBON MONOXIDE LIGHT | 30. BATTERY SWITCH |
| 11. STARTER-ON LIGHT | 31. CABIN AIR |
| 12. T.R. GEARBOX CHIP LIGHT | 32. INTERCOM |
| 13. LOW FUEL LIGHT | 33. OUTSIDE AIR TEMP/VOLTMETER |
| 14. LOW RPM LIGHT | 34. AVIONICS STACK |
| 15. ALT LOW VOLTAGE LIGHT | 35. CYCLIC RIGHT TRIM |
| 16. OIL PRESSURE LIGHT | 36. CYCLIC FRICTION |
| 17. GOVERNOR-OFF LIGHT | 37. ELT SWITCH (OPT'L) |
| 18. FULL THROTTLE LIGHT | 38. MIXTURE CONTROL |
| 19. ROTOR BRAKE LIGHT | 39. CARBURETOR HEAT |
| 20. IGNITION SWITCH | |

**OPTIONAL INSTRUMENT PANEL WITH
ASPEN EFD 1000H PFD**

(Exact panel configuration may vary with optional equipment and date of helicopter manufacture.)

INTENTIONALLY BLANK

SECTION 10

SAFETY TIPS AND NOTICES

CONTENTS

	Page
General	10-1
Safety Tips	10-1
Pilot Knowledge and Proficiency	10-4
Safety Notices	10-6

INTENTIONALLY BLANK

SECTION 10

SAFETY TIPS AND NOTICES

GENERAL

This section provides miscellaneous suggestions to help the pilot operate the helicopter more safely.

SAFETY TIPS

1. Never push the cyclic forward to descend or to terminate a pull-up (as you would in an airplane). This may produce a low-G (near weightless) condition which can result in a main rotor blade striking the cabin. Always use the collective to initiate a descent. (See Safety Notice SN-11.)
2. Never intentionally allow the fuel quantity to become so low in flight that the low fuel caution light comes on. (See Safety Notice SN-15.)
3. Never leave the helicopter unprotected where curious onlookers may inadvertently damage critical parts, such as the tail rotor blades.
4. Turn the strobe light on before starting the engine and leave it on until the rotors stop turning. The strobe light is located near the tail rotor and provides a warning to ground personnel. In-flight operation of all external lights even during daylight is recommended to promote collision avoidance.
5. Never carry an external load except when using an approved hook, and never attach anything to the outside of the helicopter. Also, be sure no loose articles are in the cabin, particularly when flying with any doors removed. Even a small, lightweight object can damage the tail rotor in flight.
6. Avoid abrupt control inputs or accelerated maneuvers, particularly at high speed. These produce high fatigue loads and, over time, could lead to failure of a critical component.

SAFETY TIPS (cont'd)

7. A change in the sound or vibration of the helicopter may indicate an impending failure of a critical component. If an unusual sound or vibration begins in flight, make a safe landing and have aircraft thoroughly inspected before flight is resumed. Hover helicopter close to the ground to verify problem is resolved, and then have aircraft reinspected before resuming free flight.
8. Take steps to ensure ground personnel or onlookers remain well clear of tail rotor and exhaust. Main rotor blades can also be dangerous, especially if personnel are upslope from helicopter.
9. Never allow rotor RPM to become dangerously low. Most hard landings will be survivable as long as the rotor is not allowed to stall.
10. Never make takeoffs or landings downwind, especially at high altitude. The resulting loss of translational lift can cause the aircraft to settle into the ground or obstacles.
11. A vertical descent or steep approach, particularly downwind, can cause the rotor to fly into its own downwash, a condition known as vortex ring state. In this condition, even maximum engine power may not be enough to stop the descent, resulting in a hard ground impact. Vortex ring state can be avoided by always reducing rate of descent before reducing airspeed. (See Safety Notice SN-22.)
12. The helicopter is stable on its landing gear as long as ground contact is made vertically or with the aircraft moving forward. Should ground contact be made with the helicopter moving rearward or sideward, damage and possibly a rollover could occur. Low-time pilots and students should practice landings and hovering with the aircraft slowly moving forward.

SAFETY TIPS (cont'd)

13. When operating at higher altitudes (above 3000 or 4000 feet), the throttle is frequently wide open and RPM must be controlled with the collective. Throttle/collective correlation is not effective under these conditions and governor response rate is fairly slow. It may be necessary to roll throttle off as collective is lowered to prevent an overspeed.
14. Do not use collective pitch to slow the rotor during shutdown. Collective pitch produces lift on the blades which can disengage the droop stop friction and allow the blades to strike the tailcone. Also, do not slow or stop the rotors by grabbing the tail rotor. Stopping the tail rotor by hand can damage the tail rotor drive.
15. Do not land in tall dry grass. The exhaust is low to the ground and very hot; a grass fire may be ignited.
16. Always check an area for wires or other obstructions before practicing autorotations.
17. Never attempt a magneto check while in flight. If one magneto is malfunctioning and the pilot grounds the other one, the engine may stop completely. If a magneto malfunction is suspected, leave the key in the BOTH position and land as soon as practical.

PILOT KNOWLEDGE AND PROFICIENCY

Pilot knowledge and proficiency is essential to safe helicopter operation. In addition to being appropriately licensed and complying with regulatory recurrency requirements such as 14 CFR §61.56 and §61.57, all pilots should seek to keep their knowledge base current and proficiency at a high level.

Periodic study and recurrent training is needed to maintain proficiency. Emphasis on the areas below is recommended. These areas should also be covered during transition training for each specific make and model that a pilot flies.

All Robinson dealers are staffed with approved instructors, and the factory can provide up-to-date information on instructors in your area.

RECOMMENDED REVIEW AND PROFICIENCY TOPICS:

NOTE

The FAA Helicopter Practical Test Standards, FAA Helicopter Flying Handbook, and commercially available helicopter training syllabi can provide detailed lessons and standards in many of the areas listed.

- All Safety Tips and Safety Notices (SNs) in the Pilot's Operating Handbook
- Limitations and Emergency Procedures
- Precision hovering, hovering turns, hover taxi (*Ref SNs 9 and 42*)
 - Safe liftoff and set down with no tendency to drift
 - Crosswind and tailwind position and directional (yaw) control
- Vortex Ring State (*Ref SNs 22 and 34*)
 - Conditions conducive
 - Recovery procedures (Vuichard and traditional)
- Loss of outside visual reference (*Ref SNs 18, 19, and 26*)
 - Seriousness of this condition
 - Traps (night flight with clouds, gradually worsening conditions, etc.)
 - Featureless terrain or glassy water

PILOT KNOWLEDGE AND PROFICIENCY (cont'd)

- Flight planning (*Ref SNs 15, 26, and 43*)
 - Thorough preflight inspection
 - Fuel
 - Weather
 - Performance (hot/high/loading)
- Distractions (*Ref SNs 16, 34, 36, and 41*)
 - Failure to keep eyes outside scanning for wires, other obstacles, and traffic
 - High workload missions such as photo flights
 - Passengers
 - Avionics
 - Cell phones
- Low-G and mast bumping (*Ref SNs 11, 29, and 32*)
 - Avoidance
 - Reduce airspeed in turbulence
 - Monitor airspeed when lightly loaded
 - Ensure passenger controls are removed
 - Recognition and recovery

CAUTION

Never practice/demonstrate low-G in flight. Low-G training should be knowledge based only.

- Low RPM considerations (*Ref SNs 10, 24, and 29*)
 - Recognition and recovery
- Power failures (*Ref SNs 10, 24, and 29*)
 - Instinctive autorotation entry
 - Continuously consider emergency landing sites throughout every flight
- Practice autorotations (*Ref SN 38*)
 - Proven, safe methods

CAUTION

In-flight practice of Low RPM, power failures, and autorotations should only be conducted under the supervision of an instructor.

- Carburetor ice (*Ref SNs 25 and 31*)
 - Conditions conducive
 - Use of carb heat

SAFETY NOTICES

The following Safety Notices have been issued by Robinson Helicopter Company as a result of various accidents and incidents. Studying the mistakes made by other pilots will help you avoid making the same errors. Safety Notices are available on the RHC website: www.robinsonheli.com.

SAFETY NOTICE

TITLE

- SN-1 Inadvertent Actuation of Mixture Control in Flight
- SN-9 Many Accidents Involve Dynamic Rollover
- SN-10 Fatal Accidents Caused by Low RPM Rotor Stall
- SN-11 Low-G Pushovers - Extremely Dangerous
- SN-13 Do Not Attach Items to the Skids
- SN-15 Fuel Exhaustion Can Be Fatal
- SN-16 Power Lines Are Deadly
- SN-17 Never Exit Helicopter with Engine Running
Hold Controls When Boarding Passengers
Never Land in Tall Dry Grass
- SN-18 Loss of Visibility Can Be Fatal
Overconfidence Prevails in Accidents
- SN-19 Flying Low Over Water is Very Hazardous
- SN-20 Beware of Demonstration or Initial Training Flights
- SN-22 Vortex Ring State Catches Many Pilots By Surprise
- SN-23 Walking into Tail Rotor Can Be Fatal
- SN-24 Low RPM Rotor Stall Can Be Fatal
- SN-25 Carburetor Ice
- SN-26 Night Flight Plus Bad Weather Can Be Deadly
- SN-27 Surprise Throttle Chops Can Be Deadly
- SN-28 Listen for Impending Bearing Failure
Clutch Light Warning
- SN-29 Airplane Pilots High Risk When Flying Helicopters
- SN-30 Loose Objects Can Be Fatal
- SN-31 Governor Can Mask Carb Ice
- SN-32 High Winds or Turbulence
- SN-33 Drive Belt Slack
- SN-34 Aerial Survey and Photo Flights - Very High Risk
- SN-35 Flying Near Broadcast Towers
- SN-36 Overspeeds During Liftoff
- SN-37 Exceeding Approved Limitations Can Be Fatal
- SN-38 Practice Autorotations Cause Many Training Accidents
- SN-39 Unusual Vibration Can Indicate a Main Rotor Blade Crack
- SN-40 Post-Crash Fires
- SN-41 Pilot Distractions
- SN-42 Unanticipated Yaw
- SN-43 Use Extra Caution During Post-Maintenance Flights
- SN-44 Carrying Passengers

Safety Notice SN-1

Issued: Jan 81 Rev Feb 89; Jun 94

INADVERTENT ACTUATION OF MIXTURE CONTROL IN FLIGHT

Cases have been reported where a pilot inadvertently pulled the mixture control instead of the carb heat or other control, resulting in sudden and complete engine stoppage. The knobs are shaped differently and the mixture control has a guard which must be removed and a push-button lock which must be depressed before actuating. These differences should be stressed when checking out new pilots. Also, in the R22, it is a good practice to always reach around the left side of the cyclic control when actuating the lateral trim. This will lessen the chance of pulling the mixture control by mistake. Always use the small plastic guard which is placed on the mixture control prior to starting the engine and is not removed until the end of the flight when the idle cut-off is pulled. Replace the guard on the mixture control so it will be in place for the next flight.

If the mixture control is inadvertently pulled, lower the collective and enter autorotation. If there is sufficient altitude, push the mixture control in and restart the engine using the left hand. DO NOT disengage the clutch.

.....

Safety Notices SN-2 thru SN-8 have been superseded or deleted.

Safety Notice SN-9

Issued: Jul 82 Rev: Jun 94

MANY ACCIDENTS INVOLVE DYNAMIC ROLLOVER

A dynamic rollover can occur whenever the landing gear contacts a fixed object, forcing the aircraft to pivot about the object instead of about its own center of gravity. The fixed object can be any obstacle or surface which prevents the skid from moving sideways. Once started, dynamic rollover cannot be stopped by application of opposite cyclic alone. For example, assume the right skid contacts an object and becomes the pivot point while the helicopter starts rolling to the right. Even with full left cyclic applied, the main rotor thrust vector will still pass on the left side of the pivot point and produce a rolling moment to the right instead of to the left. The thrust vector and its moment will follow the aircraft as it continues rolling to the right. Quickly applying down collective is the most effective way to stop a dynamic rollover.

To avoid a dynamic rollover:

- 1) Always practice hovering autorotations into the wind and never when the wind is gusty or over 10 knots.
- 2) Never hover close to fences, sprinklers, bushes, runway lights or other obstacles a skid could catch on.
- 3) Always use a two-step liftoff. Put in just enough collective to be light on the skids and feel for equilibrium, then gently lift the helicopter into the air.
- 4) Do not practice hovering maneuvers close to the ground. Keep the skids at least five feet above the ground when practicing sideward or rearward flight.

Safety Notice SN-10

Issued: Oct 82 Rev. Feb 89: Jun 94

FATAL ACCIDENTS CAUSED BY LOW RPM ROTOR STALL

A primary cause of fatal accidents in light helicopters is failure to maintain rotor RPM. To avoid this, every pilot must have his reflexes conditioned so he will instantly add throttle and lower collective to maintain RPM in any emergency.

The R22 and R44 have demonstrated excellent crashworthiness as long as the pilot flies the aircraft all the way to the ground and executes a flare at the bottom to reduce his airspeed and rate of descent. Even when going down into rough terrain, trees, wires or water, he must force himself to lower the collective to maintain RPM until just before impact. The ship may roll over and be severely damaged, but the occupants have an excellent chance of walking away from it without injury.

Power available from the engine is directly proportional to RPM. If the RPM drops 10%, there is 10% less power. With less power, the helicopter will start to settle, and if the collective is raised to stop it from settling, the RPM will be pulled down even lower, causing the ship to settle even faster. If the pilot not only fails to lower collective, but instead pulls up on the collective to keep the ship from going down, the rotor will stall almost immediately. When it stalls, the blades will either "blow back" and cut off the tailcone or it will just stop flying, allowing the helicopter to fall at an extreme rate. In either case, the resulting crash is likely to be fatal.

No matter what causes the low rotor RPM, the pilot must first roll on throttle and lower the collective simultaneously to recover RPM before investigating the problem. It must be a conditioned reflex. In forward flight, applying aft cyclic to bleed off airspeed will also help recover lost RPM.

Safety Notice SN-11

Issued: Oct 82 Rev: Nov 00

LOW-G PUSHOVERS - EXTREMELY DANGEROUS

Pushing the cyclic forward following a pull-up or rapid climb, or even from level flight produces a low-G (weightless) flight condition. If the helicopter is still pitching forward when the pilot applies aft cyclic to reload the rotor, the rotor disc may lift aft relative to the fuselage before it is reloaded. The main rotor torque reaction will then combine with tail rotor thrust to produce a powerful right rolling moment on the fuselage. With no lift from the rotor, there is no lateral control to stop the rapid right roll and mast bumping can occur. Severe in-flight mast bumping usually results in main rotor shaft separation and/or rotor blade contact with the fuselage.

The rotor must be reloaded before lateral cyclic can stop the right roll. To reload the rotor, apply an immediate gonio aft cyclic, but avoid any large aft cyclic inputs. The low-G which occurs during a rapid autorotation entry is not a problem because lowering collective reduces both rotor lift and rotor torque at the same time.

Never attempt to demonstrate or experiment with low-G maneuvers, regardless of your skill or experience level. Even highly experienced test pilots have been killed investigating the low-G flight condition. Always use great care to avoid any maneuver which could result in a low-G condition. Low-G mast bumping accidents are almost always fatal.

NEVER PERFORM A LOW-G PUSHOVER!!

Safety Notice SN-12 has been superseded by SN-24

Safety Notice SN-13

Issued: Jan 83 Rev: Jan 94

DO NOT ATTACH ITEMS TO THE SKIDS

The landing gear strut elbows have cracked on several helicopters when the pilot attempted to carry an external load strapped to the landing gear skids. The landing gear is optimized to take high "up" loads. Consequently, it has very low strength in the opposite or "down" direction. Also, even a small weight attached to the landing gear may change the natural frequency enough to cause high loads due to inflight vibration. Do not attempt to carry any external load or object attached to the landing gear.

Safety Notice SN-14 has been superseded by SN-17, SN-27 and SN-28

Safety Notice SN-15

Issued: Aug 83 Rev: Jun 94

FUEL EXHAUSTION CAN BE FATAL

Many pilots underestimate the seriousness of fuel exhaustion. Running out of fuel is the same as a sudden total engine or drive system failure. When that occurs, the pilot must immediately enter autorotation and prepare for a forced landing. Refer to Section 3 of the Pilot's Operating Handbook under Power Failure. If autorotation is not entered immediately, the RPM will rapidly decay, the rotor will stall, and the results will likely be fatal. Serious or fatal accidents have occurred as a result of fuel exhaustion.

To insure this does not happen to you, observe the following precautions:

- 1) Never rely solely on the fuel gage or the low fuel warning light. These electromechanical devices have questionable reliability in any airplane or helicopter. Always record the hourmeter reading each time the fuel tanks are filled.
- 2) During your preflight:
 - a) Check the fuel level in the tanks visually.
 - b) Be sure the fuel caps are tight.
 - c) Drain a small quantity of fuel from each tank and the gascolator to check for water or other contamination.
- 3) Before takeoff:
 - a) Insure that the fuel valve is full on.
 - b) Be sure guard is placed on mixture control.
 - c) Plan your next fuel stop so you will have at least 20 minutes of fuel remaining.
- 4) In flight:
 - a) Continually check both hourmeter and fuel gages. If either indicates low fuel, LAND.
 - b) Always land to refuel before the main tank fuel gage reads less than 1/4 full.
 - c) NEVER allow the fuel quantity to become so low in flight that the low fuel warning light comes on.

Safety Notice SN-16

Issued: Apr 84 Rev: Jun 94

POWER LINES ARE DEADLY

Flying into wires, cables, and other objects is by far the number one cause of fatal accidents in helicopters. Pilots must constantly be on the alert for this very real hazard.

- ▶ Watch for the towers; you will not see the wires in time.
 - ▶ Fly directly over the towers when crossing power lines.
 - ▶ Allow for the smaller (usually invisible, grounding wires) which are well above the larger more visible wires.
 - ▶ Constantly scan the higher terrain on either side of your flight path for towers.
 - ▶ Always maintain at least 500 feet AGL except during take-off and landing. By always flying above 500 feet AGL, you can virtually eliminate the primary cause of fatal accidents.
-

Safety Notice SN-17

Issued: Nov 84 Rev: Feb 89, Jun 94

NEVER EXIT HELICOPTER WITH ENGINE RUNNING

Several accidents have occurred when pilots momentarily left their helicopters unattended with the engine running and rotors turning. The collective can creep up, increasing both pitch and throttle, allowing the helicopter to lift off or roll out of control.

HOLD CONTROLS WHEN BOARDING PASSENGERS

It is important to firmly grip both cyclic and throttle while loading or unloading passengers with the engine running in case they inadvertently bump the controls or slide across the throttle, rolling it open.

NEVER LAND IN TALL DRY GRASS

The engine exhaust is very hot and can easily ignite tall grass or brush. One R22 was completely destroyed by fire after a normal landing in tall grass.

Safety Notice SN-18

Issued Jan 85 Rev: Feb 89; Jun 94

LOSS OF VISIBILITY CAN BE FATAL

Flying a helicopter in obscured visibility due to fog, snow, low ceiling, or even a dark night can be fatal. Helicopters have less inherent stability and much faster roll and pitch rates than airplanes. Loss of the pilot's outside visual references, even for a moment, can result in disorientation, wrong control inputs, and an uncontrolled crash. This type of situation is likely to occur when a pilot attempts to fly through a partially obscured area and realizes too late that he is losing visibility. He loses control of the helicopter when he attempts a turn to regain visibility but is unable to complete the turn without visual references.

You must take corrective action before visibility is lost! Remember, unlike the airplane, the unique capability of the helicopter allows you to land and use alternate transportation during bad weather, provided you have the good judgment and necessary willpower to make the correct decision.

OVERCONFIDENCE PREVAILS IN ACCIDENTS

A personal trait most often found in pilots having serious accidents is overconfidence. High-time fixed-wing pilots transitioning into helicopters and private owners are particularly susceptible. Airplane pilots feel confident and relaxed in the air, but have not yet developed the control feel, coordination, and sensitivity demanded by a helicopter. Private owners are their own boss and can fly without discipline, enforced rules, or periodic flight checks and critique by a chief pilot. A private owner must depend on self-discipline, which is sometimes forgotten.

When flown properly and conservatively, helicopters are potentially the safest aircraft built. But helicopters are also probably the least forgiving. They must always be flown defensively. The pilot should allow himself a greater safety margin than he thinks will be necessary, just in case.

Safety Notice SN-19

Issued Jul 85 Rev: Jun 94

FLYING LOW OVER WATER IS VERY HAZARDOUS

Many helicopter accidents have occurred while maneuvering low over water. Many pilots do not realize their loss of depth perception when flying over water. Flying over calm glassy water is particularly dangerous, but even choppy water, with its constantly varying surface, interferes with normal depth perception and may cause a pilot to misjudge his height above the water.

MAINTAIN 500 FEET AGL WHENEVER POSSIBLE AND AVOID MANEUVERS OVER WATER BELOW 200 FEET AGL.

Safety Notice SN-20

Issued: Sep 85 Rev: Jun 94

BEWARE OF DEMONSTRATION OR INITIAL TRAINING FLIGHTS

A disproportionate number of fatal and non-fatal accidents occur during demonstration or initial training flights. The accidents occur because individuals other than the pilot are allowed to manipulate the controls without being properly prepared or indoctrinated.

If a student begins to lose control of the aircraft, an experienced flight instructor can easily regain control provided the student does not make any large or abrupt control movements. If, however, the student becomes momentarily confused and makes a sudden large control input in the wrong direction, even the most experienced instructor may not be able to recover control. Instructors are usually prepared to handle the situation where the student loses control and does nothing, but they are seldom prepared for the student who loses control and does the wrong thing.

Before allowing someone to touch the controls of the aircraft, they must be thoroughly indoctrinated concerning the extreme sensitivity of the controls in a light helicopter. They must be firmly instructed to never make a large or sudden movement with the controls. And, the pilot-in-command must be prepared to instantly grip the controls should the student start to make a wrong move.

Safety Notice SN-21 has been deleted.

Safety Notice SN-22

Issued: July 1986 Revised: June 1994; October 2016

VORTEX RING STATE CATCHES MANY PILOTS BY SURPRISE

A vertical or steep approach, particularly downwind, can cause the rotor to fly into its own downwash. This condition is known as vortex ring state due to the vortices that develop as the downwash is recirculated through the rotor disk. Once vortex ring state exists, adding power (raising collective) can unexpectedly increase descent rate due to the increase in downwash recirculating through the rotor. Maximum engine power may not be enough to stop the descent before a hard landing occurs.

To avoid vortex ring state, reduce rate of descent before reducing airspeed. A good rule to follow is never allow your airspeed to be less than 30 knots until your rate-of-descent is less than 300 feet per minute.

Signs that vortex ring state is developing include increased vibration levels, decreased control authority ("mushy controls"), and a rapid increase in sink rate.

If vortex ring state is inadvertently encountered, two recovery techniques are available. One technique involves reducing collective pitch (to reduce downwash), lowering the nose to fly forward out of the downwash, and then applying recovery power. This can result in significant altitude loss which may not be acceptable on an approach.

A second technique known as the Vuichard recovery involves applying recovery power while moving the helicopter sideways, assisted by tail rotor thrust, out of the downwash. When flown properly, the Vuichard recovery produces minimal altitude loss.

Pilots should always be aware of wind conditions and plan descents to avoid vortex ring state. Training should emphasize recognition and avoidance of vortex ring state and include instruction in both recovery techniques.

Safety Notice SN-23

Issued: Jul 86 Rev: Jun 94

WALKING INTO TAIL ROTOR CAN BE FATAL

Non-pilot passengers have been killed by inadvertently walking into a rotating tail rotor. Every possible precaution must be taken by the pilot to prevent this tragic type of accident. The following rules should always be observed:

- 1) Never allow anyone to approach the helicopter unless they are escorted or have been properly instructed. If necessary, shut down and stop rotors before boarding passengers.
- 2) Always have strobe light flashing when rotors are turning.
- 3) Instruct passengers to establish and maintain eye contact with pilot when approaching helicopter. (This will force them to approach only from the nose or side, never the tail).
- 4) Instruct passengers to leave the helicopter in full view of the pilot and walk only around the nose, never the tail.
- 5) Be especially careful when landing off airports as unseen children or adults might approach the helicopter from the rear.

Safety Notice SN-24

Issued: Sep 86 Rev: Jun 94

LOW RPM ROTOR STALL CAN BE FATAL

Rotor stall due to low RPM causes a very high percentage of helicopter accidents, both fatal and non-fatal. Frequently misunderstood, rotor stall is not to be confused with retreating tip stall which occurs only at high forward speeds when stall occurs over a small portion of the retreating blade tip. Retreating tip stall causes vibration and control problems, but the rotor is still very capable of providing sufficient lift to support the weight of the helicopter.

Rotor stall, on the other hand, can occur at any airspeed and when it does, the rotor stops producing the lift required to support the helicopter and the aircraft literally falls out of the sky. Fortunately, rotor stall accidents most often occur close to the ground during takeoff or landing and the helicopter falls only four or five feet. The helicopter is wrecked but the occupants survive. However, rotor stall also occurs at higher altitudes and when it happens at heights above 40 or 50 feet AGL it is most likely to be fatal.

Rotor stall is very similar to the stall of an airplane wing at low airspeeds. As the airspeed of an airplane gets lower, the nose-up angle, or angle-of-attack, of the wing must be higher for the wing to produce the lift required to support the weight of the airplane. At a critical angle (about 15 degrees), the airflow over the wing will separate and stall, causing a sudden loss of lift and a very large increase in drag. The airplane pilot recovers by lowering the nose of the airplane to reduce the wing angle-of-attack below stall and adds power to recover the lost airspeed.

The same thing happens during rotor stall with a helicopter except it occurs due to low rotor RPM instead of low airspeed. As the RPM of the rotor gets lower, the angle-of-attack of the rotor blades must be higher to generate the lift required to support the weight of the helicopter. Even if the collective is not raised by the pilot to provide the higher blade angle, the helicopter will start to descend until the

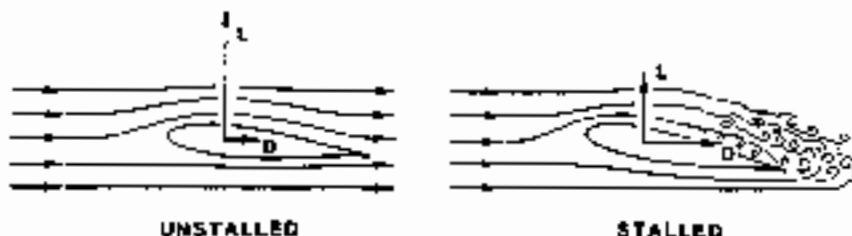

Wing or rotor blade unstalled and stalled.

Safety Notice SN-24 (continued)

upward movement of air to the rotor provides the necessary increase in blade angle-of-attack. As with the airplane wing, the blade airflow will stall at a critical angle, resulting in a sudden loss of lift and a large increase in drag. The increased drag on the blades acts like a huge rotor brake causing the rotor RPM to rapidly decrease, further increasing the rotor stall. As the helicopter begins to fall, the upward rushing air continues to increase the angle-of-attack on the slowly rotating blades, making recovery virtually impossible, even with full down collective.

When the rotor stalls, it does not do so symmetrically because any forward airspeed of the helicopter will produce a higher airflow on the advancing blade than on the retreating blade. This causes the retreating blade to stall first, allowing it to dive as it goes aft while the advancing blade is still climbing as it goes forward. The resulting low aft blade and high forward blade become a rapid aft tilting of the rotor disc sometimes referred to as "rotor blow-back". Also, as the helicopter begins to fall, the upward flow of air under the tail surfaces tends to pitch the aircraft nose-down. These two effects, combined with aft cyclic by the pilot attempting to keep the nose from dropping, will frequently allow the rotor blades to blow back and chop off the tailboom as the stalled helicopter falls. Due to the magnitude of the forces involved and the flexibility of rotor blades, rotor teeter stops will not prevent the boom chop. The resulting boom chop, however, is academic, as the aircraft and its occupants are already doomed by the stalled rotor before the chop occurs.

Safety Notice SN-25

Issued: Dec 1956 Rev: Jul 2012

CARBURETOR ICE

Avoidable accidents have been attributed to engine stoppage due to carburetor ice. When used properly, the carburetor heat and carb heat assist systems on the R22 and R44 will prevent carburetor ice.

Pressure drops and fuel evaporation inside the carburetor cause significant cooling. Therefore, carburetor ice can occur at OATs as high as 30°C (86°F). Even in generally dry air, local conditions such as a nearby body of water can be conducive to carburetor ice. **When in doubt, assume conditions are conducive to carburetor ice and apply carb heat as required.**

For the R22 and R44, carburetor heat may be necessary during takeoff. Unlike airplanes which take off at full throttle, helicopters take off using power as required, making them vulnerable to carburetor ice. Also use full carb heat during run-up to preheat the induction system.

On aircraft equipped with the carb heat assist system, the control knob should be left unlatched unless it is obvious that conditions are not conducive to carburetor ice.

Carburetor heat reduces engine power output for a given manifold pressure. Approximately 1.5 in. Hg additional MAP is required to generate maximum continuous power (MCP) or takeoff power (TOP) with full heat applied. The additional MAP with carb heat does not overstress the engine or helicopter because power limits are still being observed. Since the engine is derated, it will produce TOP at lower altitudes even with full heat. However, avoid using more heat than required at high altitudes as the engine may reach full throttle at less than MCP or TOP.

Safety Notice SN-26

Issued: Jan 87 Rev: Jun 94

NIGHT FLIGHT PLUS BAD WEATHER CAN BE DEADLY

Many fatal accidents have occurred at night when the pilot attempted to fly in marginal weather after dark. The fatal accident rate during night flight is many times higher than during daylight hours.

When it is dark, the pilot cannot see wires or the bottom of clouds, nor low hanging strud or fog. Even when he does see it, he is unable to judge its altitude because there is no horizon for reference. He doesn't realize it is there until he has actually flown into it and suddenly loses his outside visual references and his ability to control the attitude of the helicopter. As helicopters are not inherently stable and have very high roll rates, the aircraft will quickly go out of control, resulting in a high velocity crash which is usually fatal.

Be sure you NEVER fly at night unless you have clear weather with unlimited or very high ceilings and plenty of celestial or ground lights for reference.

Safety Notice SN-27

Issued: Dec 87 Rev: Jun 94

SURPRISE THROTTLE CHOPS CAN BE DEADLY

Many flight instructors do not know how to give a student a simulated power failure safely. They may have learned how to respond to a throttle chop themselves, but they haven't learned how to prepare a student for a simulated power failure or how to handle a situation where the student's reactions are unexpected. The student may freeze on the controls, push the wrong pedal, raise instead of lower the collective, or just do nothing. The instructor must be prepared to handle any unexpected student reaction.

Before giving a simulated power failure, carefully prepare your student and be sure you have flown together enough to establish that critical understanding and communication between instructor and student. Go through the exercise together a number of times until the student's reactions are both correct and predictable. Never truly surprise the student. Tell him you are going to give him a simulated power failure a few minutes before, and when you roll off the throttle, loudly announce "power failure". The manifold pressure should be less than 21 inches and the throttle should be rolled off smoothly, never "chopped". Follow through on all controls and tighten the muscles in your right leg to prevent the student from pushing the wrong pedal if he becomes confused. And always assume that you will be required to complete the autorotation entry yourself. Never wait to see what the student does. Plan to initiate the recovery within one second, regardless of the student's reaction.

There have been instances when the engine has quit during simulated engine failures. As a precaution, always perform the simulated engine failure within glide distance of a smooth open area where you are certain you could complete a safe touch-down autorotation should it become necessary. Also, never practice simulated power failures until the engine is thoroughly warmed up. Wait until you have been flying for at least 15 to 20 minutes.

Safety Notice SN-28

Issued: Jul 1988 Rev: Jul 2012

LISTEN FOR IMPENDING BEARING FAILURE

An impending ball or roller bearing failure is usually preceded by a noticeable increase in noise. The noise will typically start several hours before the bearing actually fails or before there is any increase in bearing temperature. To detect pending failure of a drive system bearing, the pilot should uncover one ear and listen to the sound of the drive system during start-up and shutdown. After the pilot becomes familiar with the normal sound of the drive system, he should be able to detect the noise made by a failing bearing. The failing bearing will produce a loud whine, rumble, growl, or siren sound. Upon hearing an unusual noise, the pilot must immediately ground the aircraft and have the bearings thoroughly inspected by a qualified mechanic. Failure of a bearing in flight could result in a serious accident.

Do not rely on Telatemps to indicate impending bearing failure. A failing bearing may not run hot enough to back out the Telatemp until it actually starts to disintegrate. This may occur only seconds before complete failure.

CLUTCH LIGHT WARNING

It is normal for the clutch light to come on occasionally in flight for a short time (approximately 3 to 5 seconds) to re-tension the drive belts. If the clutch light flickers or does not go out within 10 seconds, it can indicate a belt or bearing failure. If abnormal clutch light indication occurs, pull clutch circuit breaker and reduce power. Select a safe landing site and make a precautionary landing to check drive system. If additional symptoms of drive system failure (smell of hot rubber, noise, or vibration) are present, land immediately. If tachometer needle split occurs, enter autorotation.

After landing, shut down and check the drive belts to insure that the belts are in their grooves and not damaged. Check the upper and lower actuator bearings for seal damage. Also check the Telatemp indicator readings. If drive system problems are found, have the aircraft inspected by a mechanic before further flight.

Safety Notice SN-29

Issued: Mar 93 Rev: Jun 94

AIRPLANE PILOTS HIGH RISK WHEN FLYING HELICOPTERS

There have been a number of fatal accidents involving experienced pilots who have many hours in airplanes but with only limited experience flying helicopters.

The ingrained reactions of an experienced airplane pilot can be deadly when flying a helicopter. The airplane pilot may fly the helicopter well when doing normal maneuvers under ordinary conditions when there is time to think about the proper control response. But when required to react suddenly under unexpected circumstances, he may revert to his airplane reactions and commit a fatal error. Under those conditions, his hands and feet move purely by reaction without conscious thought. Those reactions may well be based on his greater experience, i.e., the reactions developed flying airplanes.

For example, in an airplane his reaction to a warning horn (stall) would be to immediately go forward with the stick and add power. In a helicopter, application of forward stick when the pilot hears a horn (low RPM) would drive the RPM even lower and could result in rotor stall, especially if he also "adds power" (up collective). In less than one second the pilot could stall his rotor, causing the helicopter to fall out of the sky.

Another example is the reaction necessary to make the aircraft go down. If the helicopter pilot must suddenly descend to avoid a bird or another aircraft, he rapidly lowers the collective with very little movement of the cyclic stick. In the same situation, the airplane pilot would push the stick forward to dive. A rapid forward movement of the helicopter cyclic stick under these conditions would result in a low "G" condition which could cause mast bumping, resulting in separation of the rotor shaft or one blade striking the fuselage. A similar situation exists when terminating a climb after a pull-up. The airplane pilot does it with forward stick. The helicopter pilot must use his collective or a very gradual, gentle application of forward cyclic.

To stay alive in the helicopter, the experienced airplane pilot must devote considerable time and effort in developing safe helicopter reactions. The helicopter reactions must be stronger and take precedence over the pilot's airplane reactions because everything happens faster in a helicopter. The pilot does not have time to realize he made the wrong move, think about it, and then correct it. It's too late; the rotor has already stalled or a blade has already struck the airframe and there is no chance of recovery. To develop safe helicopter reactions, the airplane pilot must practice each procedure over and over again with a competent instructor until his hands and feet will always make the right move without requiring conscious thought. **AND, ABOVE ALL, HE MUST NEVER ABRUPTLY PUSH THE CYCLIC STICK FORWARD.**

Also see Safety Notices SN-11 and SN-24.

Safety Notice SN-30

Issued: Jun 94 Rev: Apr 2009

LOOSE OBJECTS CAN BE FATAL

Fatal accidents have occurred due to loose objects flying out of the cabin and striking the tail rotor. Any object striking the tail rotor can cause failure of a tail rotor blade. Loss of or damage to a tail rotor blade may cause a severe out-of-balance condition which can separate the tail rotor gearbox or entire tail assembly from the tailcone, resulting in a catastrophic accident. Accidents have also been caused by fuel caps, birds, and other objects striking the tail rotor. Before each flight perform the following:

- 1) Walk completely around the aircraft checking fuel cap security and tail rotor condition. Ensure no loose objects or debris in helicopter vicinity. Verify cotter rings or pins are installed in all door hinge pins.
- 2) Stow or secure all loose objects in the cabin. Even with doors on, items such as charts can be sucked out of a vent door.
- 3) Instruct passengers regarding the dangers of objects striking the tail rotor. Warn them never to throw anything from the helicopter or place items near vent doors where they could get sucked out.
- 4) Firmly latch all doors.
- 5) Never fly with a left door removed. (Remove only the right door for ventilation.)

Safety Notice SN-31

Issued: Dec 96

GOVERNOR CAN MASK CARB ICE

With throttle governor on, carb ice will not become apparent as a loss of either RPM or manifold pressure. The governor will automatically adjust throttle to maintain constant RPM which will also result in constant manifold pressure. When in doubt, apply carb heat as required to keep CAT out of yellow arc during hover, climb, or cruise, and apply full carb heat when manifold pressure is below 18 inches.

Also remember, if carb heat assist is used it will reduce carb heat when you lift off to a hover and the control may require readjustment in flight.

Safety Notice SN-32

Issued: Mar 1998

Revised: May 2013; Feb 2016

HIGH WINDS OR TURBULENCE

Flying in high winds or turbulence should be avoided.

A pilot's improper application of control inputs in response to turbulence can increase the likelihood of a mast bumping accident. If turbulence is encountered, the following procedures are recommended:

1. Reduce power and use a slower than normal cruise speed. Mast bumping is less likely at lower airspeeds.
2. For significant turbulence, reduce airspeed to 60–70 knots.
3. Tighten seat belt and rest right forearm on right leg to minimize unintentional control inputs. Some pilots may choose to apply a small amount of cyclic friction to further minimize unintentional inputs.
4. Do not overcontrol. Allow aircraft to go with the turbulence, then restore level flight with smooth, gentle control inputs. Momentary airspeed, heading, altitude, and RPM excursions are to be expected.
5. Avoid flying on the downwind side of hills, ridges, or tall buildings where turbulence will likely be most severe.

The helicopter is more susceptible to turbulence at light weight. Reduce speed and use caution when flying solo or lightly loaded.

Safety Notice SN-33

Issued: March 1998 Revised: July 2013

DRIVE BELT SLACK

R22 and R44 drive belts must have the proper slack prior to engine start. Belts which are too loose may jump out of their sheave grooves during engine start while clutch is engaging.

1. During preflight, with clutch disengaged, press in on belts with fingers just above fan scroll. Verify belts deflect approximately 1 ½ inches (4 cm). If belts are significantly looser than this, have actuator adjusted prior to engine start.
2. After engine start, engage clutch and verify rotor turns within 5 seconds. If rotor does not turn within 5 seconds, shut down and have actuator adjusted prior to flight.

New drive belts may be tight and cause the rotor to turn during engine start. This places unnecessary strain on the starter and drive system. If necessary, stretch new belts as follows:

1. During shutdown, do not disengage clutch.
2. After battery switch is off, put clutch switch in DISENGAGE position. If the clutch switch is left in ENGAGE position, the tachometers still draw power and can drain the battery.
3. Switch battery on and allow clutch to disengage during next preflight.

INTENTIONALLY BLANK

Safety Notice SN-34

Issued: Mar 99 Rev: Apr 2009

AERIAL SURVEY AND PHOTO FLIGHTS – VERY HIGH RISK

There is a misconception that aerial survey and photo flights can be flown safely by low time pilots. Not true. There have been numerous fatal accidents during aerial survey and photo flights, including several involving Robinson helicopters.

Often, to please the observer or photographer, an inexperienced pilot will slow the helicopter to less than 30 KIAS and then attempt to maneuver for the best viewing angle. While maneuvering, the pilot may lose track of airspeed and wind conditions. The helicopter can rapidly lose translational lift and begin to settle. An inexperienced pilot may raise the collective to stop the descent. This can reduce RPM thereby reducing power available and causing an even greater descent rate and further loss of RPM. Rolling on throttle will increase rotor torque but not power available due to the low RPM. Because tail rotor thrust is proportional to the square of RPM, if the RPM drops below 80% nearly one-half of the tail rotor thrust is lost and the helicopter will rotate nose right. Suddenly the decreasing RPM also causes the main rotor to stall and the helicopter falls rapidly while continuing to rotate. The resulting impact is usually fatal.

Aerial survey and photo flights should only be conducted by well trained, experienced pilots who:

- 1) Have at least 500 hours pilot-in-command in helicopters and over 100 hours in the model flown;
- 2) Have extensive training in both low RPM and settling-with-power recovery techniques;
- 3) Are willing to say no to the observer or photographer and only fly the aircraft at speeds, altitudes, and wind angles that are safe and allow good escape routes.

Also see Safety Notice SN-24.

Safety Notice SN-35

Issued: Apr 1999

Revised: Feb 2016

FLYING NEAR BROADCAST TOWERS

High-power radio broadcast towers (typically 50 kW or greater) may generate Electromagnetic Interference (EMI) with helicopter electrical systems and electronic equipment. Early indications of a high-power radio field can be considerable radio squelch break or static in the intercom system. More severe effects may include random illumination of warning lights or erratic engine governor and tachometer operation. In the worst cases, the governor may attempt to fully open or close the throttle. If the pilot is not ready to counteract a governor malfunction, a low-RPM condition or overspeed may occur.

Radio field strength decreases rapidly as distance from a transmitting antenna increases. To minimize the probability of encountering EMI, do not fly within ½ mile of high-power broadcast towers.

If EMI is inadvertently encountered:

- Do not become distracted trying to adjust the radio or audio system.
- Keep one hand on the throttle twist grip and feel for normal operation. If operation is abnormal, tighten grip to override governor and control throttle manually. If desired, governor may be switched off until helicopter is clear of the EMI area.
- Monitor tachometer, engine instruments, and warning lights carefully. Use caution not to overreact to a false instrument or warning light indication.
- Following a flight where EMI was encountered, have electrical system and installed electronic equipment assessed by qualified maintenance personnel.

The location and height of radio broadcast towers are marked on aeronautical charts. However, transmitter power and frequency are not. While all broadcast towers should be circumnavigated at a safe distance, those in the HF/Short Wave band have the highest likelihood of causing EMI. A list of such towers for the United States can be found on the Robinson Helicopter Company website at www.robinsonheli.com/sn35antennas. The list was compiled from a Federal Communications Commission (FCC) database of HF/Shortwave stations. Appropriate agencies in other countries may be able to provide similar databases.

Safety Notice SN-36

Issued: Nov 00

OVERSPEEDS DURING LIFTOFF

Helicopters have been severely damaged by RPM overspeeds during liftoff. The overspeeds caused a tail rotor drive shaft vibration which led to immediate failure of shaft and tailcone. Throughout the normal RPM range, tail rotor shaft vibration is controlled by camper bearing. However, damper is not effective above 120% RPM.

Mechanical correlation can cause overspeed during liftoff if RPM is increased to normal flight settings and collective raised before governor is switched on. Overspeeds can also occur if throttle is gripped too firmly during liftoff causing governor to be overridden. Inexperienced pilots, who are most likely to be nervous or distracted, are particularly susceptible to this type of overspeed.

To avoid overspeeds during liftoff:

1. Always confirm governor on before increasing RPM above 80%.
2. Verify governor stabilizes engine RPM near top of green arc.
3. Maintain relaxed grip on throttle allowing governor to control RPM.

Safety Notice SN-37

Issued: Dec 01

EXCEEDING APPROVED LIMITATIONS CAN BE FATAL

Many pilots do not understand metal fatigue. Each time a metal component is loaded to a stress level above its fatigue limit, hidden damage occurs within the metal. There is no inspection method which can detect this invisible fatigue damage. The first indication will be a tiny microscopic crack in the metal, often hidden from view. The crack will grow with each repetition of the critical stress until the part suddenly breaks. Crack growth will occur quite rapidly in drive system parts from the high frequency torsional loads. It will also occur rapidly in rotor system components due to the high centrifugal force on the blades and hub. Damaging fatigue cycles occur with every revolution of an overloaded drive shaft or rotor blade.

If a pilot exceeds the power or airspeed limits on a few occasions without failure, he may be misled into believing he can safely operate at those high loads. Not true. Every second the limitations are exceeded, more stress cycles occur and additional fatigue damage can accumulate within the metal. Eventually, a fatigue crack will begin and grow until a sudden failure occurs. If the pilot is lucky, the part will have reached its approved service life and be replaced before failure. If not, there will likely be a serious or fatal accident.

WARNING

- 1) Always operate the aircraft well below its approved Vne (never exceed speed), especially in turbulent wind conditions.
- 2) Do not operate the engine above its placarded manifold pressure limits.
- 3) Do not load the aircraft above its approved gross weight limit.
- 4) The most damaging conditions occur when flying or maneuvering at high airspeeds combined with high power settings.

Safety Notice SN-38

Issued: Jul 2003 Rev: Jul 2019

PRACTICE AUTOROTATIONS CAUSE MANY TRAINING ACCIDENTS

Practice autorotations continue to be the number one cause of helicopter training accidents. Many of these accidents occur because the instructor fails to take decisive action.

Instructors should always perform the following "100 Foot Decision Check":

- 1) Rotor RPM approximately 100%
- 2) Stabilized airspeed between 60 and 70 KIAS
- 3) Stabilized rate of descent, usually less than 1500 ft/min.
- 4) Turns (if any) completed

Prior to descending below 100 feet AGL, the instructor must make the decision to take the flight controls and make an immediate power recovery if any of the above parameters is not correct. Do not attempt to salvage the situation by coaching the student or trying to correct below 100 feet AGL. At density altitudes above 4000 feet, increase the decision check to 200 feet AGL or higher.

If the decision to continue is made, the instructor should announce "100 Foot Check complete, continue".

A high percentage of training accidents occur after many consecutive autorotations. To maintain instructor focus and minimize student fatigue, limit practice to no more than 3 or 4 consecutive autorotations.

The purpose of the practice autorotation is to teach control and maneuvering during the glide, proper use of the flare, and the power recovery (or landing). While simulated power failure/forced landing practice may involve more abrupt power reduction, practice autorotation entries should be accomplished smoothly and slowly in accordance with the Robinson Flight Training Guide.

Safety Notice SN-39

Issued: Jul 2003

UNUSUAL VIBRATION CAN INDICATE A MAIN ROTOR BLADE CRACK

A catastrophic rotor blade fatigue failure can be averted if pilots and mechanics are alert to early indications of a fatigue crack. Although a crack may be internal to blade structure and not visible, it will likely cause a significant increase in rotor vibration prior to final failure. If a rotor is smooth after balancing but then goes out of balance again within a few flights, it should be considered suspect. Have the rotor system thoroughly examined by a qualified mechanic before further flight.

If main rotor vibration rapidly increases or becomes severe during flight, make an immediate safe landing. Do not attempt to continue flight to a convenient destination.

Safety Notice SN-40

Issued: July 2006 Rev: May 2013

POST-CRASH FIRES

There have been a number of cases where helicopter or light plane occupants were severely burned by fire following an accident. Fire-retardant Nomex flight apparel reduces the likelihood of severe burns. Military, law-enforcement, medical, and other organizations often require Nomex apparel for every flight. Pilots should consider the benefits of fire-retardant clothing and brief or equip all occupants accordingly.

Safety Notice SN-41

Issued: May 2013

PILOT DISTRACTIONS

Distractions in the cabin have caused pilots to lose control of the helicopter. Reading charts, programming avionics, or attending to passengers are some common distractions. During flight, it is important to keep eyes focused outside and minimize distractions to avoid an accident. Any avionics programming that takes more than a few seconds should be done while on the ground.

When hovering, keep both hands on the controls. If tuning a radio or other task is required, first land and reduce collective pitch. When dealing with distractions in forward flight, reduce power, slow down, and frequently look outside to verify straight and level flight.

Occasionally, pilots neglect to latch a door before taking off. Never attempt to latch a door while hovering or in flight. It is safer to land before closing a door.

Safety Notice SN-42

Issued: May 2013 Rev: Jul 2019

UNANTICIPATED YAW

A pilot's failure to apply proper pedal inputs in response to strong or gusty winds during hover or low-speed flight may result in an unanticipated yaw. Some pilots mistakenly attribute this yaw to loss of tail rotor effectiveness (LTE), implying that the tail rotor stalled or was unable to provide adequate thrust. Tail rotors on Robinson helicopters are designed to have more authority than many other helicopters and are unlikely to experience LTE.

To avoid unanticipated yaw, pilots should be aware of conditions (a left crosswind, for example) that may require large or rapid pedal inputs. Practicing slow, steady-rate hovering pedal turns will help maintain proficiency in controlling yaw. Hover training with a qualified instructor in varying wind conditions may also be helpful.

Note that thrust of any tail rotor decreases significantly as RPM decreases. Low RPM combined with high torque, as occurs when over-pitching, may result in an uncontrollable right yaw (see also Safety Notice SN-34).

Safety Notice SN-43

Issued: January 2015

USE EXTRA CAUTION DURING POST-MAINTENANCE FLIGHTS

A number of fatal accidents have occurred during flights immediately following maintenance. In several cases, the cause was incorrect or incomplete reassembly of the helicopter, and the error would have been detectable during a careful preflight inspection.

Even the best maintenance personnel can become distracted and make a mistake. Pilots should conduct an especially thorough preflight inspection after maintenance has been performed. If possible, speak to the technicians who performed the work, find out exactly what was done, and pay special attention to those areas. Professional maintenance personnel will appreciate the pilot's commitment to safety and will welcome an additional check of their work.

Any work done on the flight control system deserves special attention because a flight control disconnect is almost always catastrophic. During track and balance work, always climb up to the rotor head for a close inspection of the pitch link and control tube fasteners after each adjustment. Never rush or skip preflight steps.

Safety Notice SN-44

Issued: February 2017 Revised: June 2017

CARRYING PASSENGERS

Carrying passengers is an additional responsibility for the pilot in command. Passengers have placed their trust entirely in the hands of the pilot and should be advised of risks associated with the flight. Risks include pilot experience level, aircraft capability, and operational considerations such as flight over water or night flight. Carrying a passenger in and of itself increases risk because passengers add workload and distractions.

Passenger Briefings

Always conduct a passenger safety briefing before allowing a passenger on board. Passenger safety briefings should include:

- Risks: A discussion of the risks associated with the flight. Ensure passengers know that you will be happy to cancel or discontinue a flight if anyone is uncomfortable.
- Entry and exit: Have passengers demonstrate proper operation of seatbelts and doors. Brief safe emergency entry and exit paths (away from tail rotor and within pilot's view). Do not board or disembark passengers with rotors turning unless procedures (such as ground escorts) are established before the flight.
- Aircraft controls: Always remove passenger-side controls. Ensure passengers secure any personal items brought on board. Caution passengers against inadvertently bumping the cyclic center post. Ensure passengers know how to operate headsets and intercom system.
- Expectations for the flight: Adhering to fixed schedules or flying over landmarks may not be possible due to weather, airspace, or performance limitations. If passengers are aware of these limitations prior to the flight, there will be less pressure for the pilot to attempt a task beyond his comfort or experience level.
- High workload times: Passengers should always tell the pilot about safety-related items such as traffic but should refrain from unnecessary conversation during takeoff, landing, and radio communications.

Safety Notice SN-44 (continued)

Newly-Rated Pilots

Accident data shows that new pilots carrying passengers have high accident rates. The workload and distractions added by passengers are magnified for new pilots who may still be getting used to the aircraft and operating environment. Newly-rated helicopter pilots:

- Should not carry passengers until accumulating 100 total hours helicopter experience including 20 hours pilot in command in type after receiving their helicopter rating.
- Should only fly in daylight with good VFR conditions and low winds.
- For the first several passenger-carrying flights, should limit flight to a local, familiar area.

Related Safety Notices

- SN-30 (doors-off flight with passengers is not recommended unless they have significant helicopter familiarity).
- SN-34 (photo missions have risks well beyond regular passenger carrying flights and require specific training and experience).