

# **EMBRAER 190**

EMBRAER S.A  
12227-901 SAO JOSE DOS CAMPOS - S.P.  
BRAZIL  
PHONE: + 55 12 3927-7517  
<http://www.embraer.com>  
e-mail: [distrib@embraer.com.br](mailto:distrib@embraer.com.br)

---

# **AIRPORT PLANNING MANUAL**

In connection with the use of this document, Embraer does not provide any express or implied warranties and expressly disclaims any warranty of merchantability or fitness for a particular purpose.

This document contains trade secrets, confidential, proprietary information of Embraer and technical data subject to U.S. Export Administration Regulation ("EAR") and other countries export control laws and regulations. Diversion contrary to the EAR and other laws regulations is strictly forbidden. The above restrictions may apply to data on all pages of this document.

APM-1901  
15 AUGUST 2005  
REVISION 17 - 22 MAY 2020





**EMBRAER S.A.**

AV. BRIGADEIRO FARIA LIMA, 2.170 - PHONE: + 55 12 3927-7517  
CEP 12.227-901 - SÃO JOSÉ DOS CAMPOS - SÃO PAULO - BRASIL  
e-mail: [distrib@embraer.com.br](mailto:distrib@embraer.com.br) - <http://www.embraer.com>

TO: HOLDERS OF PUBLICATION No. **APM-1901** - "AIRPORT PLANNING MANUAL".

FRONT MATTER - REVISION No. 17 DATED MAY 22/2020

Pages which have been added, revised, or deleted by the current revision are indicated by an asterisk, on the List of Effective Pages.

This issue incorporates all preceding Temporary Revisions (if any).





# EMBRAER 190 AIRPORT PLANNING MANUAL

## RECORD OF REVISIONS

The user must update the Record of Revisions when a revision is put into the manual.

REV No.	ISSUE DATE	DATE INSERTED	BY	REV No.	ISSUE DATE	DATE INSERTED	BY

RETAIN THIS RECORD IN THE FRONT OF MANUAL OR CHAPTER.  
ON RECEIPT OF REVISIONS, INSERT REVISED PAGES IN THE MANUAL, AND ENTER REVISION NUMBER, DATE INSERTED AND INITIALS.





**RECORD OF TEMPORARY REVISIONS**

Temporary Rev. No.	Page Number	Issued Date	By	Date Removed	By







## TEMPORARY REVISION STATUS REPORT

This list is intended to show the operator which temporary revisions are applicable to his fleet. The list consists of the temporary revision number, the related issue date, the incorporation date, and the affected subject.

**S\* INDICATES TR HAS BEEN SUPERSEDED BY THE TR REFERRED TO.**

EFFECTIVITY: ALL

**TR STATUS REPORT**





## **LIST OF SERVICE BULLETINS**

This list is intended to let the operator know which Service Bulletins are incorporated to the APM.

The list consists of the Service Bulletin numbers and the respective revisions (if applicable), the affected section (s) (APM Section Number), information on whether the Service Bulletin affects the manual, the aircraft (Effectivity) affected by the Service Bulletins and the incorporation date.

A revision bar is placed on the left margin of the list whenever data are inserted or revised.

NOTE: The effectivity is indicated by means of two numerical groups separated by a dash. The first group presented in the effectivity column corresponds to the last digits of the lowest aircraft designation number to indicate the beginning of the effectivity, and the second group corresponds to the last digits of the highest aircraft designation number to indicate the end of the effectivity.





# EMBRAER 190 AIRPORT PLANNING MANUAL

Title		3-1 .....	Oct 07/13
BLOCK		3-2 .....	Oct 07/13
PAGE	REVISION	3-3 .....	Oct 07/13
TRList		3-4 .....	Oct 07/13
1 .....	Oct 22/07	3-5 .....	Oct 07/13
2 Blank .....	Oct 22/07	3-6 .....	Oct 07/13
SBList		3-7 .....	Oct 07/13
1 .....	Jan 09/06	3-8 .....	Oct 07/13
2 Blank .....	Aug 15/05	3-9 .....	Oct 07/13
List of Effective Pages		3-10 .....	Oct 07/14
* 1 (rev) .....	May 22/20	3-11 .....	Oct 07/14
* 2 (rev) .....	May 22/20	3-12 .....	Oct 07/14
Table of Contents		3-13 .....	Oct 07/14
* 1 (rev) .....	May 22/20	3-14 .....	Oct 07/14
2 .....	May 11/07	3-15 .....	Oct 07/14
List of Tables		3-16 .....	Oct 07/14
* 1 (rev) .....	May 22/20	3-17 .....	Oct 07/14
2 Blank .....	Aug 15/05	3-18 .....	Oct 07/14
List of Figures		3-19 .....	Oct 07/14
* 1 (rev) .....	May 22/20	3-20 .....	Oct 07/14
* 2 (rev) .....	May 22/20	3-21 .....	Oct 07/14
* 3 (rev) .....	May 22/20	3-22 .....	Oct 07/14
4 Blank .....	Aug 15/05	3-23 .....	Oct 07/14
Section 1		3-24 .....	Oct 07/14
1-1 .....	Jan 09/06	3-25 .....	Oct 07/14
1-2 .....	Aug 09/19	3-26 .....	Oct 07/14
1-3 .....	Oct 06/11	3-27 .....	Oct 07/14
1-4 Blank .....	Aug 15/05	3-28 .....	Oct 07/14
Section 2		Section 4	
2-1 .....	Oct 07/13	4-1 .....	Oct 07/13
2-2 .....	Oct 07/13	4-2 .....	Oct 07/13
2-3 .....	Oct 07/13	4-3 .....	Oct 07/13
2-4 .....	Oct 07/13	4-4 .....	Oct 07/13
* 2-5 (rev) .....	May 22/20	4-5 .....	Sep 27/19
* 2-6 (rev) .....	May 22/20	4-6 .....	May 25/18
* 2-7 (rev) .....	May 22/20	4-7 .....	May 25/18
* 2-8 (rev) .....	May 22/20	4-8 .....	May 25/18
* 2-9 (rev) .....	May 22/20	4-9 .....	May 25/18
* 2-10 (rev) .....	May 22/20	4-10 .....	May 25/18
* 2-11 (rev) .....	May 22/20	4-11 .....	May 25/18
* 2-12 (rev) .....	May 22/20	4-12 .....	May 25/18
* 2-13 (rev) .....	May 22/20	4-13 .....	May 25/18
* 2-14 (rev) .....	May 22/20	4-14 Blank .....	May 25/18
* 2-15 (rev) .....	May 22/20	Section 5	
* 2-16 (rev) .....	May 22/20	5-1 .....	Oct 07/13
* 2-17 (add) .....	May 22/20	5-2 .....	Oct 07/13
* 2-18 (add) .....	May 22/20	* 5-3 (rev) .....	May 22/20
Section 3		5-4 .....	Oct 07/13

Pages revised or added by the current revision are indicated by an asterisk (\*). Pages deleted by the current revision are indicated by \* (del). Pages deleted by the previous revision are indicated by (del).

EFFECTIVITY: ALL

## LIST OF EFFECTIVE PAGES

REV. 17

Page 1

May 22/20



# EMBRAER 190 AIRPORT PLANNING MANUAL

5-5 .....	Oct 07/13	Section 8	
5-6 .....	Oct 07/13	8-1 .....	Oct 07/13
5-7 .....	Oct 07/13	8-2 Blank .....	Oct 07/13
5-8 .....	Oct 07/13	Section 9	
5-9 .....	May 25/18	9-1 .....	Oct 07/13
5-10 .....	Oct 07/13	9-2 .....	Oct 07/13
5-11 .....	Oct 07/13	9-3 .....	Oct 07/13
5-12 .....	Oct 07/13	9-4 .....	Oct 07/13
* 5-13 (rev) .....	May 22/20	9-5 .....	Oct 07/13
5-14 Blank .....	Oct 07/13	9-6 .....	Oct 07/13
Section 6			
6-1 .....	Oct 07/13		
6-2 .....	Oct 07/13		
6-3 .....	Oct 07/13		
6-4 .....	Oct 07/13		
6-5 .....	Oct 07/13		
6-6 .....	Oct 07/13		
6-7 .....	Oct 07/13		
6-8 .....	Oct 07/13		
6-9 .....	Oct 07/13		
6-10 .....	Oct 07/13		
6-11 .....	Oct 07/13		
6-12 Blank .....	Oct 07/13		
Section 7			
7-1 .....	Oct 07/13		
7-2 .....	Oct 07/13		
7-3 .....	Oct 07/13		
7-4 .....	Oct 07/13		
7-5 .....	Oct 07/13		
7-6 .....	Oct 07/13		
7-7 .....	Oct 07/13		
7-8 .....	Oct 07/13		
7-9 .....	Oct 07/13		
7-10 .....	Oct 07/13		
7-11 .....	Oct 07/13		
7-12 .....	Oct 07/13		
7-13 .....	Oct 07/13		
7-14 .....	Oct 07/13		
7-15 .....	Sep 27/19		
7-16 .....	Oct 07/13		
7-17 .....	Oct 07/13		
7-18 Blank .....	Oct 07/13		
7-19 (del) .....	Dec 18/06		
7-20 (del) .....	Dec 18/06		
7-21 (del) .....	Dec 18/06		
7-22 (del) .....	Dec 18/06		
7-23 (del) .....	Dec 18/06		
7-24 Blank (del) .....	Dec 18/06		

Pages revised or added by the current revision are indicated by an asterisk (\*). Pages deleted by the current revision are indicated by \* (del). Pages deleted by the previous revision are indicated by (del).

EFFECTIVITY: ALL

## LIST OF EFFECTIVE PAGES

REV. 17

Page 2

May 22/20



**TABLE OF CONTENTS**

**SECTION 1 - SCOPE**

1.	Scope .....	1-1
1.1.	Purpose .....	1-1
1.2.	Introduction .....	1-1
1.3.	Abbreviations .....	1-2

**SECTION 2 - AIRCRAFT DESCRIPTION**

2.	Aircraft Description .....	2-1
2.1.	Aircraft Characteristics .....	2-1
2.2.	General Aircraft Dimensions .....	2-2
2.3.	Ground Clearances .....	2-8
2.4.	Interior Arrangements .....	2-12
2.5.	Passenger Cabin Cross Section .....	2-15
2.6.	Lower Compartment Containers .....	2-17
2.7.	Door Clearances .....	2-18

**SECTION 3 - AIRCRAFT PERFORMANCE**

3.	Aircraft Performance .....	3-1
3.1.	General Information .....	3-1
3.2.	Payload X Range .....	3-2
3.3.	Takeoff Field Lengths .....	3-9
3.4.	Landing Fields Lengths .....	3-20

**SECTION 4 - GROUND MANEUVERING**

4.	Ground Maneuvering .....	4-1
4.1.	General Information .....	4-1
4.2.	Turning Radii .....	4-1
4.3.	Minimum Turning Radii .....	4-3
4.4.	Visibility From Cockpit .....	4-4
4.5.	Runway and Taxiway Dimensions .....	4-5
4.6.	Runway Holding Apron .....	4-12

**SECTION 5 - TERMINAL SERVICING**

5.	Terminal Servicing .....	5-1
5.1.	Aircraft Servicing Arrangement .....	5-2
5.2.	Terminal Operations - Turnaround Station .....	5-4
5.3.	Terminal Operations - En Route Station .....	5-6
5.4.	Ground Servicing Connections .....	5-7
5.5.	Engine Starting Pneumatic Requirements .....	5-9
5.6.	Ground Pneumatic Power Requirements .....	5-10
5.7.	Preconditioned Airflow Requirements .....	5-11
5.8.	Ground Towing Requirements .....	5-13

EFFECTIVITY: ALL



**SECTION 6 - OPERATING CONDITIONS**

6.	Operating Conditions .....	6-1
6.1.	Engine Exhaust Velocities and Temperatures .....	6-2
6.2.	Airport and Community Noise .....	6-9
6.3.	Hazard Areas .....	6-10

**SECTION 7 - PAVEMENT DATA**

7.	Pavement Data .....	7-1
7.1.	General Information .....	7-1
7.2.	Footprint .....	7-2
7.3.	Maximum Pavement Loads .....	7-3
7.4.	Landing Gear Loading on Pavement .....	7-4
7.5.	Flexible Pavement Requirements, US Corps of Engineers Design Method .....	7-5
7.6.	Flexible Pavement Requirements, LCN Method .....	7-7
7.7.	Rigid Pavement Requirements, Portland Cement Association Design Method .....	7-9
7.8.	Rigid Pavement Requirements, LCN Method .....	7-11
7.9.	ACN - PCN System - Flexible and Rigid Pavements .....	7-15

**SECTION 8 - POSSIBLE EMBRAER 190 DERIVATIVE AIRCRAFT**

8.	Possible EMBRAER 190 Derivative Aircraft .....	8-1
8.1.	Not Applicable .....	8-1

**SECTION 9 - SCALED DRAWINGS**

9.	Scaled Drawings .....	9-1
9.1.	General .....	9-1

EFFECTIVITY: ALL

**TABLE OF CONTENTS**





**LIST OF TABLES**

<u>TABLE</u>	<u>TITLE</u>	<u>SECTION</u>	<u>PAGE</u>
1.1	APM Arrangement .....	01	1
2.1	Aircraft General Characteristics .....	02	2
2.2	Ground Clearance - STD Aircraft Model .....	02	9
2.3	Ground Clearance - LR Aircraft Model.....	02	10
2.4	Ground Clearance - AR Aircraft Model .....	02	11
2.5	Capacity for the Cargo Compartment .....	02	14
3.1	ISA.....	03	1
4.1	Reference Codes.....	04	5
7.1	Pavement Evaluation.....	07	15

EFFECTIVITY: ALL

**LIST OF TABLES**





**LIST OF FIGURES**

FIGURE	TITLE	SHEET	SECTION	PAGE
2.1	General Aircraft Dimensions .....		02	4
2.2	Passenger and Service Doors Dimensions .....	1 of 3	02	5
2.2	Passenger and Service Doors Dimensions .....	2 of 3	02	6
2.2	Passenger and Service Doors Dimensions .....	3 of 3	02	7
2.3	Aircraft Ground Clearances.....		02	8
2.4	Typical Interior Arrangements .....		02	13
2.5	Economy Class Passenger Cabin Cross-Section.....		02	15
2.6	First Class Passenger Cabin Cross-Section.....		02	16
2.7	Door Dimensions.....		02	18
3.1	Payload x Range - ISA Conditions .....		03	3
3.2	Payload x Range - ISA + 10 °C Conditions .....		03	4
3.3	Payload x Range - ISA Conditions .....		03	5
3.4	Payload x Range - ISA + 10 °C Conditions .....		03	6
3.5	Payload x Range - ISA Conditions .....		03	7
3.6	Payload x Range - ISA + 10 °C Conditions .....		03	8
3.7	Takeoff Field Lengths - ISA Conditions .....		03	10
3.8	Takeoff Field Lengths - ISA + 15 °C Conditions.....		03	11
3.9	Takeoff Field Lengths - ISA Conditions .....		03	12
3.10	Takeoff Field Lengths - ISA + 15 °C Conditions.....		03	13
3.11	Takeoff Field Lengths - ISA Conditions .....		03	14
3.12	Takeoff Field Lengths - ISA + 15 °C Conditions.....		03	15
3.13	Takeoff Field Lengths - ISA Conditions .....		03	16
3.14	Takeoff Field Lengths - ISA + 15 °C Conditions.....		03	17
3.15	Takeoff Field Lengths - ISA Conditions .....		03	18
3.16	Takeoff Field Lengths - ISA + 15 °C Conditions.....		03	19
3.17	Landing Field Lengths - Flaps 5 .....		03	21
3.18	Landing Field Lengths - Flaps Full .....		03	22
3.19	Landing Field Lengths - Flaps 5 .....		03	23

EFFECTIVITY: ALL

**LIST OF FIGURES**



# EMBRAER 190 AIRPORT PLANNING MANUAL

FIGURE	TITLE	SHEET	SECTION	PAGE
3.20	Landing Field Lengths - Flaps Full .....		03	24
3.21	Landing Field Lengths - Flaps 5 .....		03	25
3.22	Landing Field Lengths - Flaps Full .....		03	26
3.23	Landing Field Lengths - Flaps 5 .....		03	27
3.24	Landing Field Lengths - Flaps Full .....		03	28
4.1	Turning Radii - No Slip Angle .....		04	2
4.2	Minimum Turning Radius .....		04	3
4.3	Visibility from Cockpit in Static Position .....		04	4
4.4	More than 90° Turn - Runway to Taxiway .....		04	7
4.5	More than 90° Turn - Runway to Taxiway .....		04	8
4.6	90° Turn - Runway to Taxiway .....		04	9
4.7	90° Turn - Runway to Taxiway .....		04	10
4.8	90° Turn - Taxiway to Taxiway .....		04	11
4.9	Runway Holding Bay .....		04	12
4.10	Runway Holding Bay .....		04	13
5.1	Aircraft Servicing Arrangement With Passenger Stairs .....		05	2
5.2	Aircraft Servicing Arrangement With Passenger Bridge .....		05	3
5.3	Air Terminal Operation - Turnaround Station .....		05	5
5.4	Ground Servicing Connections .....		05	7
5.5	Ground Servicing Connections .....		05	8
5.6	Engine Starting Pneumatic Requirements .....		05	9
5.7	Ground Pneumatic Power Requirements .....		05	10
5.8	Preconditioned Airflow Requirements .....		05	12
5.9	Ground Towing Requirements .....		05	13
6.1	Jet Wake Velocity Profile - Takeoff Power .....		06	2
6.2	Jet Wake Temperature Profile - Takeoff Power .....		06	3
6.3	Jet Wake Velocity Profile - Ground Idle .....		06	4
6.4	Jet Wake Temperature Profile - Ground Idle .....		06	5
6.5	Jet Wake Velocity Profile - Breakaway Power .....	1 of 2	06	6
6.5	Jet Wake Velocity Profile - Breakaway Power .....	2 of 2	06	7

EFFECTIVITY: ALL

## LIST OF FIGURES



# EMBRAER 190 AIRPORT PLANNING MANUAL

FIGURE	TITLE	SHEET	SECTION	PAGE
6.6	Jet Wake Temperature Profile - Breakaway Power .....		06	8
6.7	Hazard Areas - Takeoff Power .....		06	10
6.8	Hazard Areas - Ground Idle .....		06	11
7.1	Footprint .....		07	2
7.2	Maximum Pavement Loads.....		07	3
7.3	Landing Gear Loading on Pavement.....		07	4
7.4	Flexible Pavement Requirements - US Army Corps of Engineers Design Method .....		07	6
7.5	Flexible Pavement Requirements - LCN Method .....		07	8
7.6	Rigid Pavement Requirements - Portland Cement Association Design Method .....		07	10
7.7	Radius of Relative Stiffness .....		07	12
7.8	Radius of Relative Stiffness (other values).....		07	13
7.9	Rigid Pavement Requirements - LCN Method .....		07	14
7.10	ACN For Flexible Pavement .....		07	16
7.11	ACN For Rigid Pavement.....		07	17
9.1	Scale: 1 Inch Equals 32 Feet.....		09	2
9.2	Scale: 1 Inch Equals 50 Feet.....		09	3
9.3	Scale: 1 Inch Equals 100 Feet.....		09	4
9.4	Scale: 1 to 500 .....		09	5
9.5	Scale: 1 to 1000.....		09	6

EFFECTIVITY: ALL

## LIST OF FIGURES





**1. SCOPE**

**1.1. PURPOSE**

This document provides airplane characteristics for general airport planning. Since the operational practices vary among the airlines, specific data should be coordinated with the using airlines before the facility design is made.

EMBRAER should be contacted for any additional information required.

**1.2. INTRODUCTION**

The APM has been prepared in accordance with NAS 3601.

It provides aircraft characteristics for general airport planning, airport operators, airlines, and engineering consultant organizations.

The APM is arranged as shown in the table below:

Table 1.1 - APM Arrangement

ARRANGEMENTS	CONTENTS
Manual Front Matter	Title Page
	Customer Comment Form
	Highlights
	Record of Revision Sheet
	Temporary Revision Sheet
	List of Service Bulletins
	List of Effective Pages
	Table of Contents
	List of Tables
	List of Figures
Section	Scope
	Aircraft Description
	Aircraft Performance
	Ground Maneuvering
	Terminal Servicing
	Operating Conditions
	Pavement Data
	Possible Derivative Aircraft
	Scaled Drawings

The front matter for the whole manual contains:

- Title Page: Shows the manufacturer’s masthead, identification of the manual, the initial issue date, and revision number and date.
- Highlights: Advises the operator on the revised pages.
- Record of Revisions Sheet: Lists the successive revision numbers, issue date, insertion date and incorporators initials, which must be kept current by the operator.

EFFECTIVITY: ALL
------------------



# EMBRAER 190 AIRPORT PLANNING MANUAL

- List of Service Bulletins: Lists the Service Bulletins, including all issued revisions, which affect the manual as well as the affected section(s) (APM Section Number), the aircraft affected by the Service Bulletin, and the date of incorporation of the SB in the manual.
- Temporary Revision Sheet: Lists the temporary revision numbers, page number, issue date, person responsible for the insertion and insertion date.
- List of Effective Pages: Lists all sections and their list of effective pages with the latest issue dates.
- Queries concerning any printed material, including purchasing, copying, shipping and handling, complaints, or compliments may be addressed to:  
Technical Publications Distribution:  
Embraer S.A.  
Attention of: Technical Publications Department  
CEP. 12.227-901- São José dos Campos - SP - Brazil  
Phone: (55 12) 3927-7517  
<http://www.embraer.com>  
e-mail: [distrib@embraer.com.br](mailto:distrib@embraer.com.br)
- For support regarding technical information contained in non-operational publication, please contact:  
Routine Issues: Contact Embraer Customer Support Service  
AOG Issues: Contact Embraer AOG group directly

## 1.2.1. Revisions

Embraer may revise this manual periodically as required to update information or provide information not available at the time of printing.

Revised data may result from Embraer approved aircraft modifications and new available options. Changes to the text are indicated by a black bar in the page left-side margin, beside the revised, added, or deleted material.

Relocated or rearranged text or illustrations will be indicated by a black bar beside the page number.

## 1.3. ABBREVIATIONS

This list gives all the abbreviations, acronyms and measurement units used in this manual with their definitions.

Table 1.2 - List of Acronyms and Abbreviations used in the APM

ACRONYMS AND ABBREVIATIONS	DESCRIPTION
°C	Degree Celsius
°F	Degree Fahrenheit
ℓ	Liter
ACN	Aircraft Classification Number
AFM	Airplane Flight Manual
AOM	Airplane Operations Manual

EFFECTIVITY: ALL

**Section 1**

Page 1-2

Aug 09/19





# EMBRAER 190 AIRPORT PLANNING MANUAL

Table 1.2 - List of Acronyms and Abbreviations used in the APM

ACRONYMS AND ABBREVIATIONS	DESCRIPTION
APM	Airport Planning Manual
APU	Auxiliary Power Unit
AR	Advanced Range
ATTCS	Automatic Takeoff-Thrust Control-System
BOW	Basic Operating Weight
CBR	California Bearing Ratio
ECS	Environmental Control System
FAA	Federal Aviation Administration
FAR	Federal Aviation Regulations
FWD	Forward
GEAE	General Electric Aircraft Engines
ICAO	International Civil Aviation Organization
ISA	International Standard Atmosphere
JAR	Joint Aviation Requirements
LCN	Load Classification Number
LH	Left-Hand
LR	Long Range
MLW	Maximum Landing Weight
MRW	Maximum Ramp Weight
MTOW	Maximum Takeoff Weight
MZFW	Maximum Zero Fuel Weight
N	Newton
RBHA	Requisitos Brasileiros de Homologação Aeronáutica
RH	Right-Hand
STD	Standard
dBA	A-Weighted Decibel
ft	Foot
ft <sup>2</sup>	Square Foot
ft <sup>3</sup>	Cubic Foot
gal.	Gallon
in	Inch
in <sup>2</sup>	Square Inch
inHg	Inch of Mercury
kPa	Kilopascal
kg	Kilogram
lb	Pound
lb/in <sup>3</sup>	Pound per Cubic Inch
lbf	Pound Force
m	Meter
m <sup>2</sup>	Square Meter
m <sup>3</sup>	Cubic Meter
min	Minute
psi	Pounds per Square Inch

EFFECTIVITY: ALL





## **2. AIRCRAFT DESCRIPTION**

### **2.1. AIRCRAFT CHARACTERISTICS**

The aircraft is:

- Predominantly metallic;
- Low winged;
- Conventional tailed;
- Monoplane;
- Retractable tricycle-type with twin-wheeled landing-gear.

There are two high bypass ratio turbofan GEAE CF34-10 with 82.3 kN (18500 lbf) maximum takeoff thrust (Sea Level, Static Condition and ISA) installed under the wings.

The aircraft has three versions, with different ranges as a function of the difference between the MTOWs:

- The STD aircraft model - MTOW 47790 kg (105359 lb);
- The LR aircraft model - MTOW 50300 kg (110892 lb);
- The AR aircraft model - MTOW 51800 kg (114199 lb).

#### **2.1.1. Definitions**

##### **MRW**

It is the maximum allowed aircraft weight for taxiing or maneuvering on the ground.

##### **MLW**

It is the maximum allowed weight at which the aircraft may normally be landed.

##### **MTOW**

It is the maximum allowed total loaded aircraft weight at the start of the takeoff run.

##### **BOW**

It is the weight of the structure, powerplant, instruments, flight controls, hydraulic, electronic, electrical, air conditioning, oxygen, anti-icing and pressurization systems, interior furnishings, portable and emergency equipment and other items of equipment that are an integral part of the aircraft configuration. It also includes unusable fuel, total engine and APU oil, total hydraulic fluid, toilet fluid and water, potable water, crew and crew baggage, navigation kit (manuals, charts), catering (beverages and food) and removable service equipment for the galley.

##### **MZFW**

It is the maximum allowed weight without usable fuel in tanks.

EFFECTIVITY: ALL



**Maximum Payload**

It is the difference between the MZFW and the BOW.

**Maximum Seating Capacity**

It is the maximum number of passengers specifically certified or anticipated for certification.

**Maximum Cargo Volume**

It is the maximum space available for cargo.

**Usable Fuel**

Fuel available for the aircraft propulsion.

Table 2.1 - Aircraft General Characteristics

DESIGN WEIGHTS <sup>[1]</sup>	AIRCRAFT MODELS		
	STD	LR	AR
MRW	47950 kg (105712 lb)	50460 kg (111245 lb)	51960 kg (114552 lb)
MTOW	47790 kg (105359 lb)	50300 kg (110892 lb)	51800 kg (114199 lb)
MLW	43000 kg (94799 lb)		44000 kg (97003 lb)
BOW <sup>[2]</sup>	27900 kg (61509 lb)		
MZFW	40800 kg (89949 lb)		40900 kg (90169 lb)
Maximum Payload <sup>[2]</sup>	12900 kg (28440 lb)		13000 kg (28660 lb)
Maximum Seating Capacity	106 passengers		
Maximum Cargo Volume <sup>[3]</sup>	22.63 m <sup>3</sup> (799.18 ft <sup>3</sup> )		
Usable Fuel <sup>[4]</sup>	13000 kg (28660 lb)		
	16029 ℓ (4234 gal.)		

1. Applicable for standard models. For further information, refer to AFM and AOM.
2. Typical standard configuration (weights may vary according to optional equipment installed or interior layouts).
3. Standard configuration (volume may vary according to optional equipment installed).
4. Adopted fuel density of 0.811 kg/ℓ (6.77 lb/gal.).

**2.2. GENERAL AIRCRAFT DIMENSIONS**

**2.2.1. External Dimensions**

- Span over winglets - 28.72 m (94 ft 3 in.)
- Height (maximum) - 10.55 m (34 ft 7 in.)
- Overall length - 36.24 m (118 ft 11 in.)

**2.2.2. Wing**

- Reference area - 92.50 m<sup>2</sup> (996 ft<sup>2</sup>)
- Reference aspect ratio - 8.1

EFFECTIVITY: ALL



**2.2.3. Fuselage**

- Total Length - 36.24 m (118 ft 11 in.)
- Length of pressurized section - 29.08 m (95 ft 5 in.)

**2.2.4. Horizontal Tail**

- Span - 12.08 m (39 ft 8 in.)
- Area - 26.00 m<sup>2</sup> (280 ft<sup>2</sup>)

**2.2.5. Vertical Tail**

- Reference area - 16.20 m<sup>2</sup> (174 ft<sup>2</sup> 54 in<sup>2</sup>)



# EMBRAER 190 AIRPORT PLANNING MANUAL

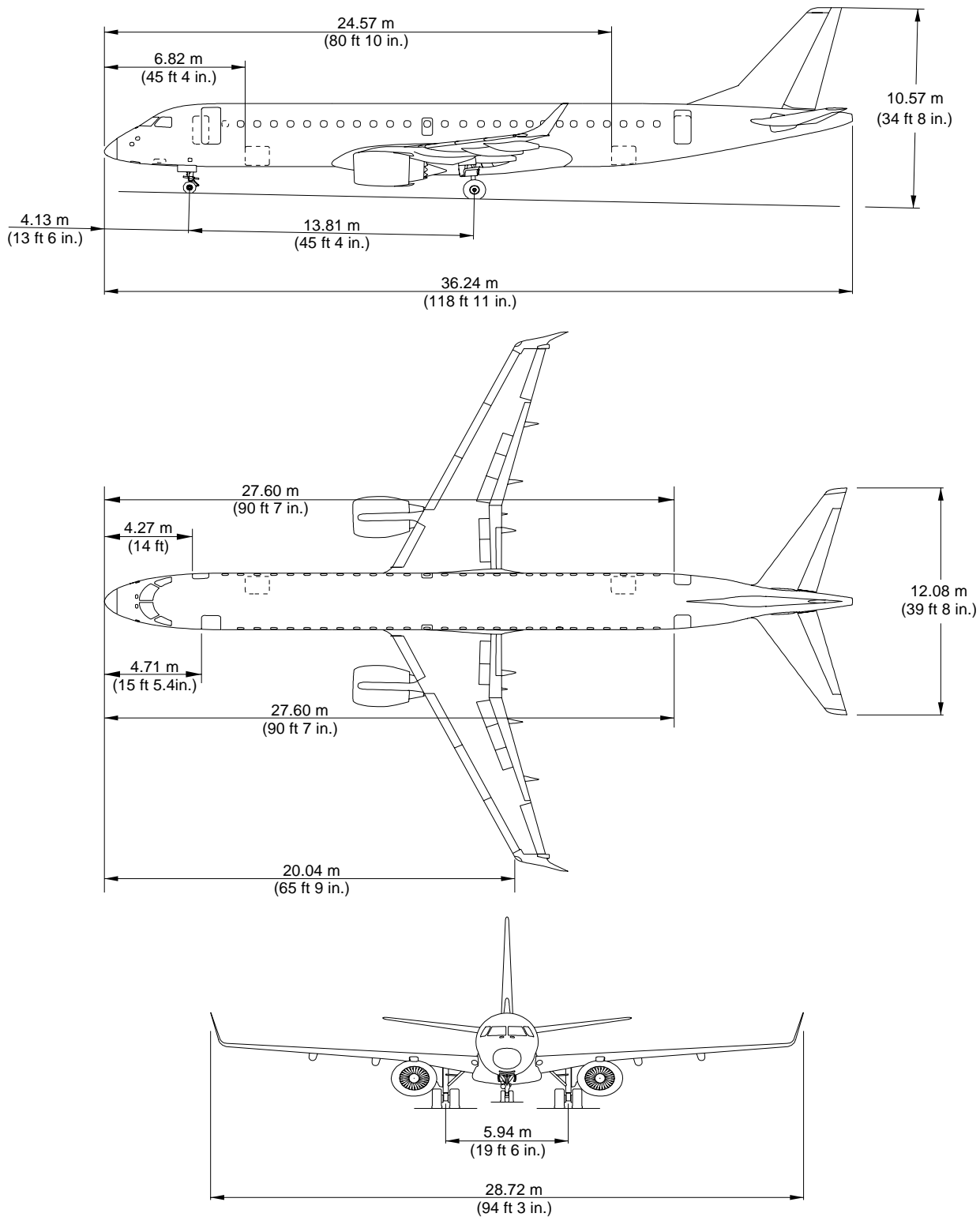

EM170APM020011B.DGN

General Aircraft Dimensions  
Figure 2.1

EFFECTIVITY: ALL

Section 2

Page 2-4

Oct 07/13



# EMBRAER 190 AIRPORT PLANNING MANUAL

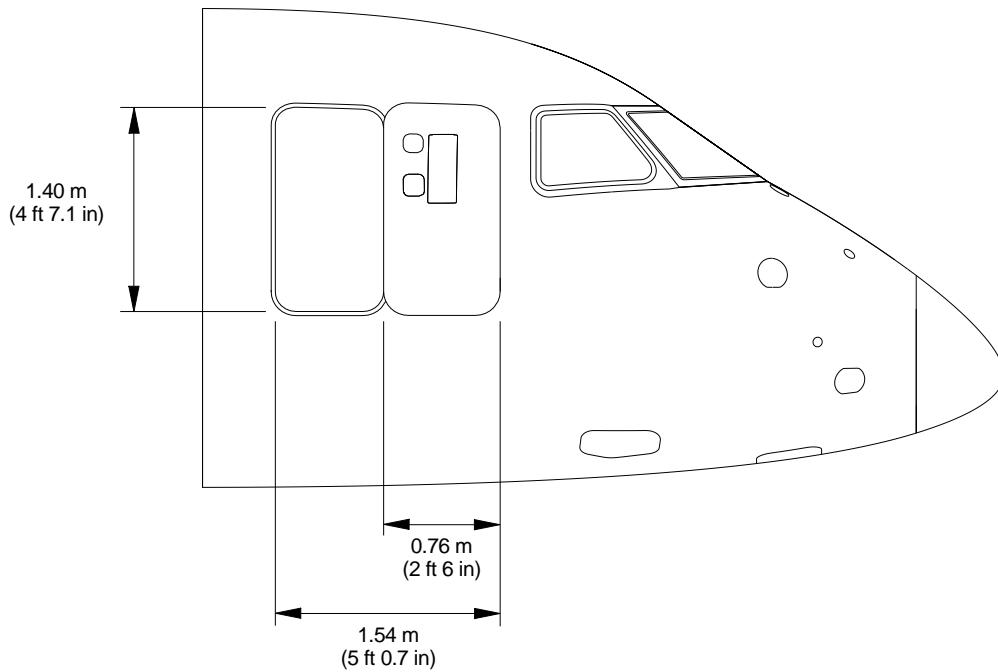
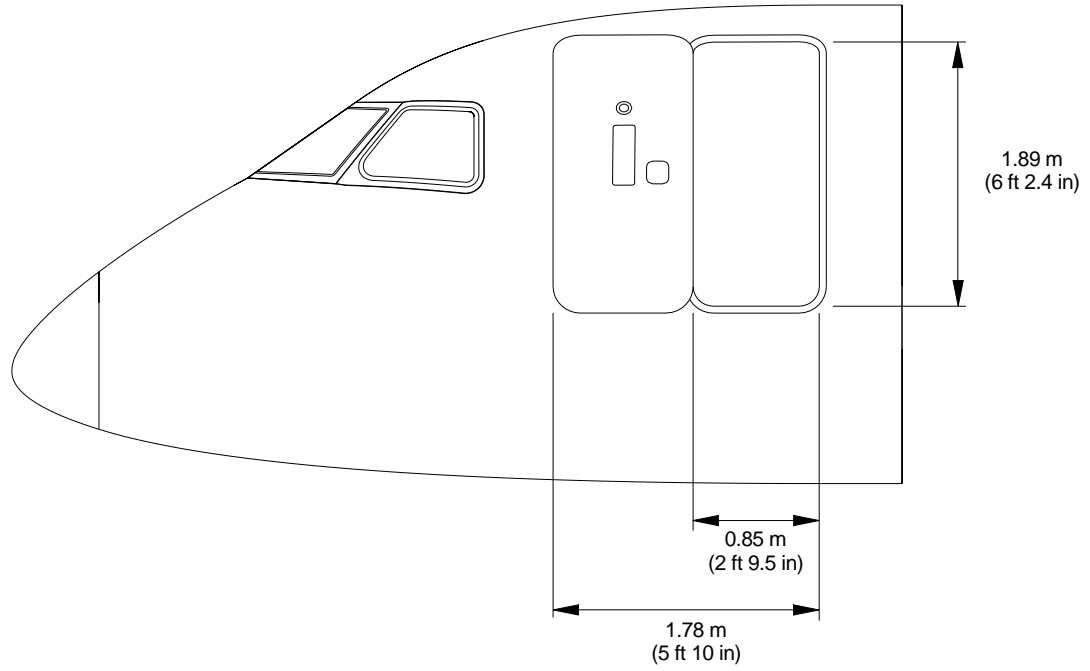

Passenger and Service Doors Dimensions  
Figure 2.2  
Sheet 1

EIM170APM020026A.IDR

EFFECTIVITY: ALL



# EMBRAER 190 AIRPORT PLANNING MANUAL

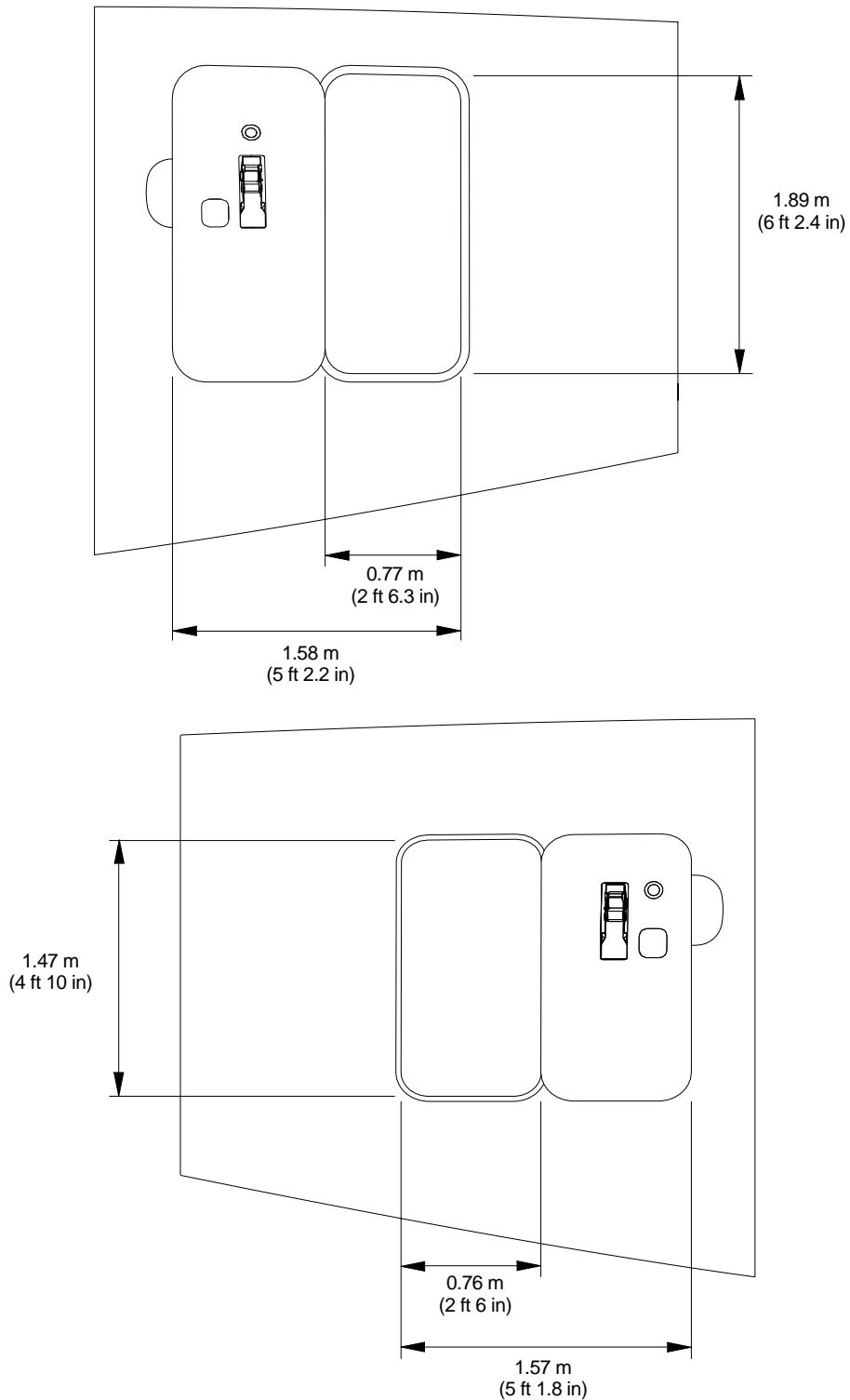

Passenger and Service Doors Dimensions  
Figure 2.2  
Sheet 2

EM170APM020027A.IDR

EFFECTIVITY: ALL





# EMBRAER 190 AIRPORT PLANNING MANUAL

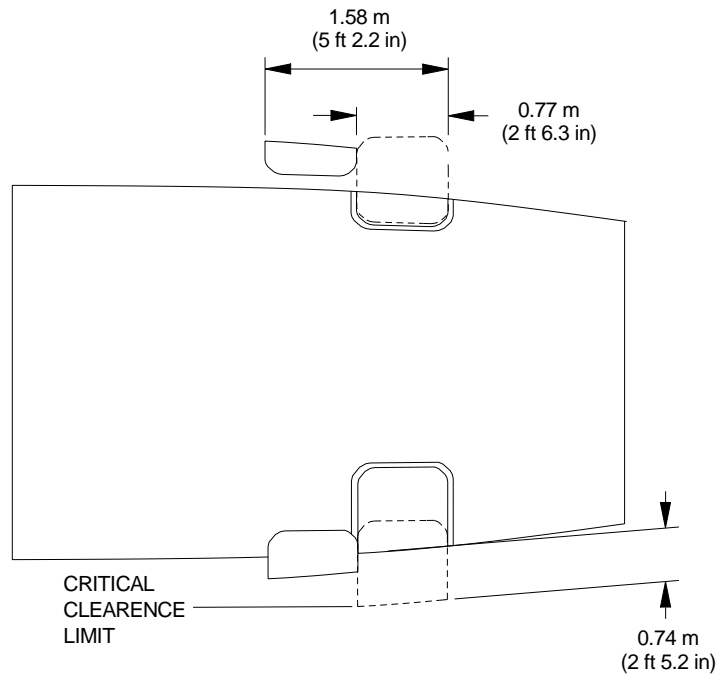
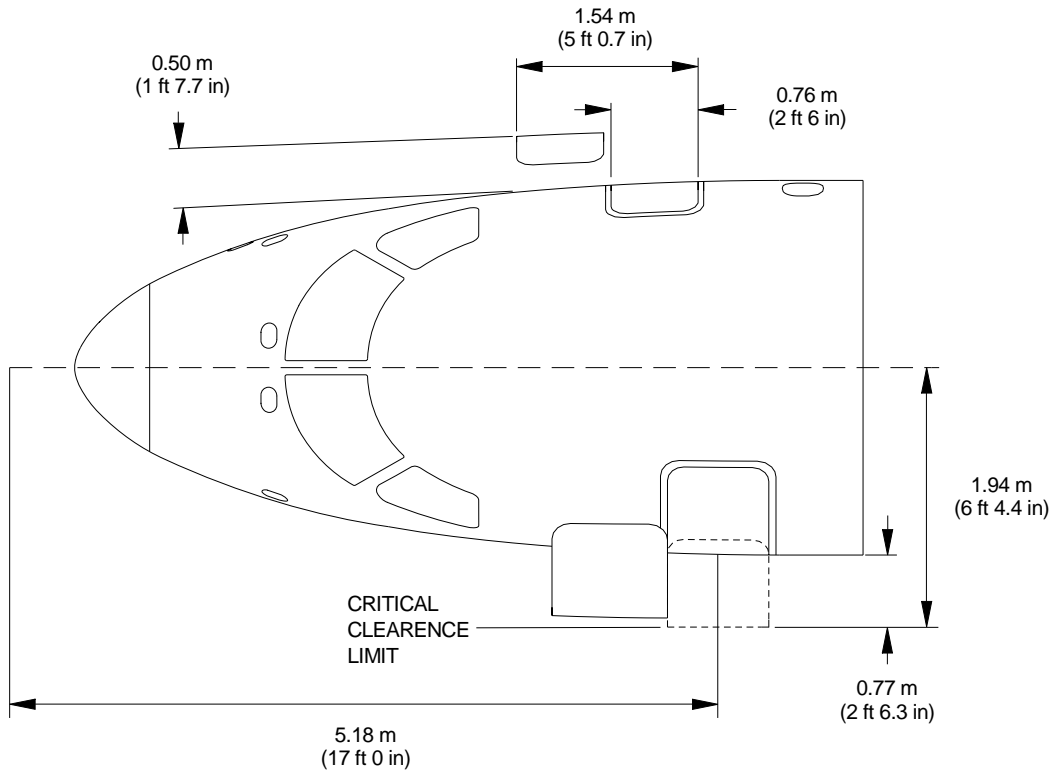

Passenger and Service Doors Dimensions  
Figure 2.2  
Sheet 3

EM170AFPM020028A.IDR

EFFECTIVITY: ALL



**2.3. GROUND CLEARANCES**

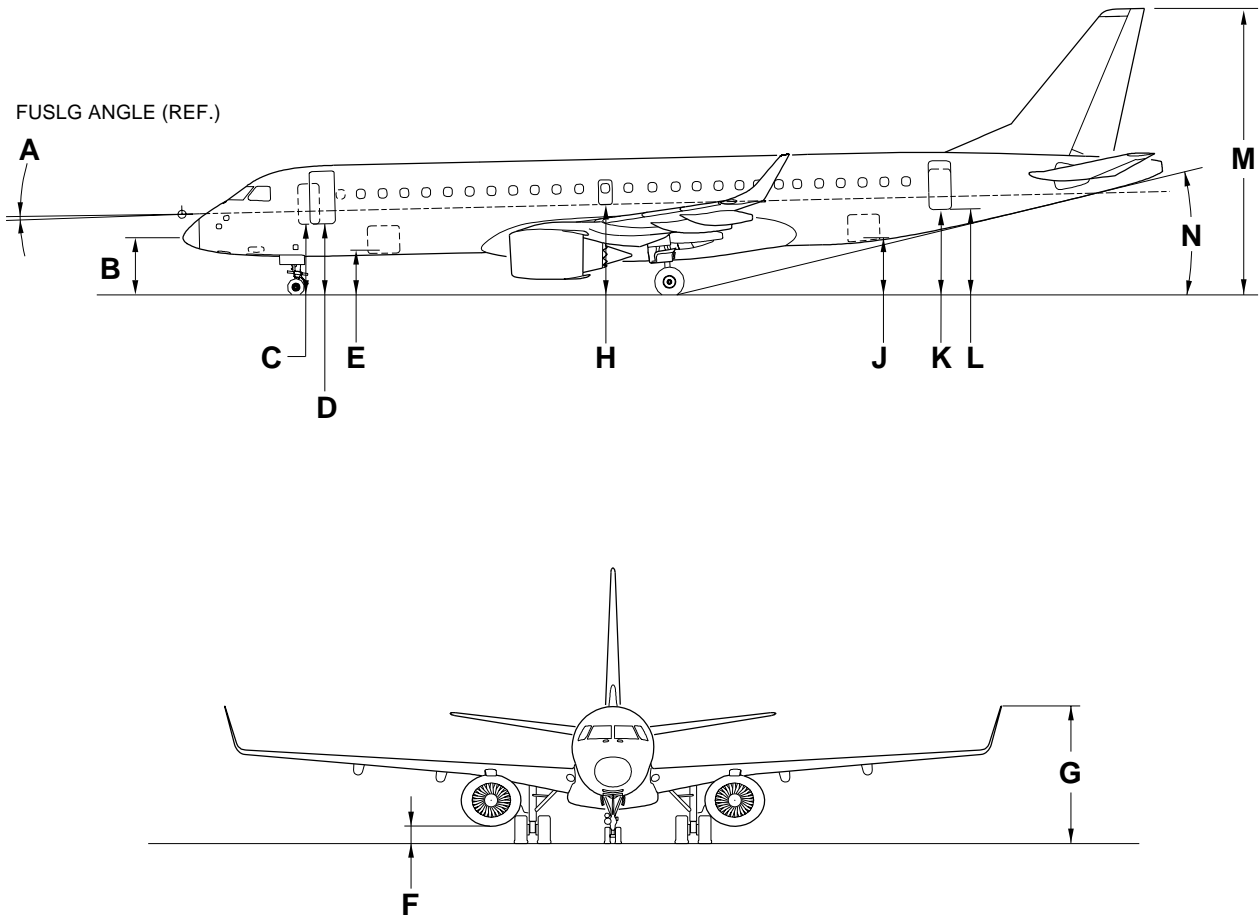

EM170MFEP020013B.DGN

Aircraft Ground Clearances  
Figure 2.3

EFFECTIVITY: ALL



Table 2.2 - Ground Clearance - STD Aircraft Model

WEIGHT	CG (%MAC)	FUS ANGLE (DEG) (A)	NOSE (B)	FORWARD SERVICE DOOR (C)	FORWARD PASSENGER DOOR (D)	FORWARD CARGO DOOR (E)	NA-CELLE (F)	WINGLET (G)	EMERGENCY EXIT (H)	AFT CARGO DOOR (J)	AFT SERVICE DOOR (K)	AFT PASSENGER DOOR (L)	VERTICAL TAIL (M)	TAIL SKID ANGLAR CLEARANCE (DEG) (N)
47950 kg 105712 lb	6.0	-1.1	2.07 m 6 ft 9 in.	2.58 m 8 ft 5 in.	2.59 m 8 ft 6 in.	1.57 m 5 ft 2 in.	0.49 m 1 ft 7 in.	5.09 m 16 ft 8 in.	3.24 m 10 ft 8 in.	1.99 m 6 ft 5 in.	3.03 m 9 ft 9 in.	3.03 m 9 ft 9 in.	10.40 m 34 ft 2 in.	12.7
47950 kg 105712 lb	28.7	-0.8	2.13 m 7 ft	2.63 m 8 ft 7 in.	2.64 m 8 ft 8 in.	1.61 m 5 ft 3 in.	0.50 m 1 ft 8 in.	5.05 m 16 ft 7 in.	3.24 m 10 ft 8 in.	1.94 m 6 ft 4 in.	2.97 m 8 ft 8 in.	2.97 m 8 ft 8 in.	10.33 m 33 ft 9 in.	12.4
47790 kg 105359 lb	6.0	-1.1	2.05 m 6 ft 9 in.	2.58 m 8 ft 5 in.	2.59 m 8 ft 6 in.	1.57 m 5 ft 2 in.	0.49 m 1 ft 7 in.	5.09 m 16 ft 8 in.	3.24 m 10 ft 8 in.	1.99 m 6 ft 6 in.	3.03 m 9 ft 11 in.	3.03 m 9 ft 11 in.	10.43 m 34 ft 2 in.	12.7
47790 kg 105359 lb	28.7	-0.8	2.13 m 7 ft	2.63 m 8 ft 7 in.	2.64 m 8 ft 8 in.	1.61 m 5 ft 3 in.	0.50 m 1 ft 8 in.	5.06 m 16 ft 7 in.	3.24 m 10 ft 8 in.	1.94 m 6 ft 4 in.	2.97 m 9 ft 8 in.	2.97 m 9 ft 8 in.	10.33 m 33 ft 10 in.	12.3
43000 kg 94799 lb	6.0	-1.1	2.06 m 6 ft 9 in.	2.59 m 8 ft 6 in.	2.60 m 8 ft 6 in.	1.58 m 5 ft 2 in.	0.50 m 1 ft 8 in.	5.12 m 16 ft 9 in.	3.26 m 10 ft 8 in.	2.00 m 6 ft 7 in.	3.06 m 9 ft 12 in.	3.06 m 9 ft 12 in.	10.45 m 34 ft 3 in.	12.8
43000 kg 94799 lb	29.0	-0.8	2.14 m 7 ft	2.65 m 8 ft 8 in.	2.66 m 8 ft 9 in.	1.63 m 5 ft 4 in.	0.51 m 1 ft 8 in.	5.08 m 16 ft 8 in.	3.26 m 10 ft 8 in.	1.96 m 6 ft 5 in.	2.99 m 9 ft 9 in.	2.99 m 9 ft 9 in.	10.35 m 33 ft 10 in.	12.4
40800 kg 89949 lb	6.0	-1.1	2.06 m 6 ft 9 in.	2.59 m 8 ft 6 in.	2.60 m 8 ft 6 in.	1.59 m 5 ft 3 in.	0.51 m 1 ft 8 in.	5.13 m 16 ft 10 in.	3.27 m 10 ft 9 in.	2.02 m 6 ft 7 in.	3.07 m 10 ft	3.07 m 10 ft	10.47 m 34 ft 4 in.	12.9
40800 kg 89949 lb	29.0	-0.8	2.15 m 7 ft	2.65 m 8 ft 8 in.	2.66 m 8 ft 9 in.	1.64 m 5 ft 5 in.	0.52 m 1 ft 9 in.	5.09 m 16 ft 8 in.	3.27 m 10 ft 9 in.	1.98 m 6 ft 5 in.	3.00 m 9 ft 10 in.	3.00 m 9 ft 10 in.	10.36 m 33 ft 11 in.	12.5

EFFECTIVITY: ALL



# EMBRAER 190 AIRPORT PLANNING MANUAL

Table 2.3 - Ground Clearance - LR Aircraft Model

WEIGHT	CG (%MAC)	FUS ANGLE (DEG) (A)	NOSE (B)	FORWARD SERVICE DOOR (C)	FORWARD PASSENGER DOOR (D)	FORWARD CARGO DOOR (E)	NA-CELLE (F)	WINGLET (G)	EMERGENCY EXIT (H)	AFT CARGO DOOR (J)	AFT SERVICE DOOR (K)	AFT PASSENGER DOOR (L)	VERTICAL TAIL (M)	TAIL SKID ANGLAR CLEARANCE (DEG) (N)
50460 kg 111245 lb	8.8	-1.1	2.06 m 6 ft 9 in.	2.58 m 8 ft 5 in.	2.58 m 8 ft 5 in.	1.57 m 5 ft 2 in.	0.48 m 1 ft 7 in.	5.08 m 16 ft 8 in.	3.23 m 10 ft 7 in.	1.97 m 6 ft 5 in.	3.02 m 9 ft 10 in.	3.02 m 9 ft 10 in.	10.40 m 34 ft 1 in.	12.6
50460 kg 111245 lb	27.6	-0.8	2.12 m 7 ft	2.62 m 8 ft 8 in.	2.63 m 8 ft 7 in.	1.60 m 5 ft 4 in.	0.49 m 1 ft 7 in.	5.05 m 16 ft 7 in.	3.24 m 10 ft 7 in.	1.94 m 6 ft 4 in.	2.97 m 9 ft 8 in.	2.97 m 9 ft 8 in.	10.33 m 33 ft 9 in.	12.3
50300 kg 110892 lb	8.8	-1.1	2.06 m 6 ft 9 in.	2.58 m 8 ft 5 in.	2.58 m 8 ft 5 in.	1.57 m 5 ft 2 in.	0.48 m 1 ft 7 in.	5.08 m 16 ft 8 in.	3.23 m 10 ft 7 in.	1.97 m 6 ft 5 in.	3.02 m 9 ft 10 in.	3.02 m 9 ft 10 in.	10.40 m 34 ft 1 in.	12.6
50300 kg 110892 lb	27.6	-0.8	2.12 m 7 ft	2.62 m 8 ft 8 in.	2.63 m 8 ft 7 in.	1.60 m 5 ft 4 in.	0.49 m 1 ft 7 in.	5.05 m 16 ft 7 in.	3.24 m 10 ft 7 in.	1.94 m 6 ft 4 in.	2.97 m 9 ft 8 in.	2.97 m 9 ft 8 in.	10.33 m 33 ft 9 in.	12.3
43000 kg 94799 lb	6.0	-1.1	2.06 m 6 ft 9 in.	2.59 m 8 ft 6 in.	2.60 m 8 ft 6 in.	1.58 m 5 ft 2 in.	0.50 m 1 ft 8 in.	5.12 m 16 ft 9 in.	3.26 m 10 ft 8 in.	2.00 m 6 ft 7 in.	3.06 m 9 ft 12 in.	3.06 m 9 ft 12 in.	10.45 m 34 ft 3 in.	12.8
43000 kg 94799 lb	29.0	-0.8	2.14 m 7 ft	2.65 m 8 ft 8 in.	2.66 m 8 ft 9 in.	1.63 m 5 ft 4 in.	0.51 m 1 ft 8 in.	5.08 m 16 ft 8 in.	3.26 m 10 ft 8 in.	1.96 m 6 ft 5 in.	2.99 m 9 ft 9 in.	2.99 m 9 ft 9 in.	10.35 m 33 ft 10 in.	12.4
40800 kg 89949 lb	6.0	-1.1	2.06 m 6 ft 9 in.	2.59 m 8 ft 6 in.	2.60 m 8 ft 6 in.	1.59 m 5 ft 3 in.	0.51 m 1 ft 8 in.	5.13 m 16 ft 10 in.	3.27 m 10 ft 9 in.	2.02 m 6 ft 7 in.	3.07 m 10 ft	3.07 m 10 ft	10.47 m 34 ft 4 in.	12.9
40800 kg 89949 lb	29.0	-0.8	2.15 m 7 ft 2 in.	2.65 m 8 ft 8 in.	2.66 m 8 ft 9 in.	1.64 m 5 ft 5 in.	0.52 m 1 ft 9 in.	5.09 m 16 ft 8 in.	3.27 m 10 ft 9 in.	1.98 m 6 ft 5 in.	3.00 m 9 ft 10 in.	3.00 m 9 ft 10 in.	10.36 m 33 ft 11 in.	12.5

EFFECTIVITY: ALL



Table 2.4 - Ground Clearance - AR Aircraft Model

WEIGHT	CG (%MAC)	FUS ANGLE (DEG) (A)	NOSE (B)	FORWARD SERVICE DOOR (C)	FORWARD PASSENGER DOOR (D)	FORWARD CARGO DOOR (E)	NA-CELLE (F)	WINGLET (G)	EMERGENCY EXIT (H)	AFT CARGO DOOR (J)	AFT SERVICE DOOR (K)	AFT PASSENGER DOOR (L)	VERTICAL TAIL (M)	TAIL SKID ANGLAR CLEARANCE (DEG) (N)
51960 kg 114552lb	10.7	-1.1	2.06 m 6 ft 9 in.	2.58 m 8 ft 5 in.	2.59 m 8 ft 6 in.	1.57 m 5 ft 2 in.	0.48 m 1 ft 7 in.	5.08 m 16 ft 8 in.	3.23 m 10 ft 7 in.	1.97 m 6 ft 5 in.	3.01 m 9 ft 10 in.	3.01 m 9 ft 10 in.	10.40 m 34 ft 1 in.	12.6
51960 kg 114552lb	27.0	-0.8	2.12 m 7 ft	2.62 m 8 ft 8 in.	2.63 m 8 ft 7 in.	1.60 m 5 ft 4 in.	0.49 m 1 ft 7 in.	5.05 m 16 ft 7 in.	3.23 m 10 ft 7 in.	1.93 m 6 ft 4 in.	2.96 m 9 ft 8 in.	2.96 m 9 ft 8 in.	10.32 m 33 ft 9 in.	12.3
51800kg 11499lb	10.7	-1.1	2.06 m 6 ft 9 in.	2.58 m 8 ft 5 in.	2.59 m 8 ft 6 in.	1.57 m 5 ft 2 in.	0.48 m 1 ft 7 in.	5.08 m 16 ft 8 in.	3.23 m 10 ft 7 in.	1.97 m 6 ft 5 in.	3.01 m 9 ft 10 in.	3.01 m 9 ft 10 in.	10.40 m 34 ft 1 in.	12.6
51800kg 11499lb	27.0	-0.8	2.12m 7 ft	2.62 m 8 ft 8 in.	2.63 m 8 ft 7 in.	1.60 m 5 ft 4 in.	0.49 m 1 ft 7 in.	5.05 m 16 ft 7 in.	3.23 m 10 ft 7 in.	1.93 m 6 ft 4 in.	2.96 m 9 ft 8 in.	2.96 m 9 ft 8 in.	10.33 m 33 ft 9 in.	12.3
44000 kg 97003 lb	6.0	-1.1	2.06 m 6 ft 9 in.	2.59 m 8 ft 6 in.	2.60 m 8 ft 6 in.	1.58 m 5 ft 2 in.	0.50 m 1 ft 8 in.	5.11 m 16 ft 9 in.	3.26 m 10 ft 8 in.	2.00 m 6 ft 7 in.	3.03 m 9 ft 12 in.	3.03 m 9 ft 12 in.	10.45 m 34 ft 3 in.	12.8
44000 kg 97003 lb	29.0	-0.8	2.14 m 7 ft	2.64 m 8 ft 8 in.	2.65 m 8 ft 8 in.	1.63 m 5 ft 4 in.	0.51 m 1 ft 8 in.	5.07 m 16 ft 8 in.	3.26 m 10 ft 8 in.	1.96 m 6 ft 5 in.	2.99 m 9 ft 9 in.	2.99 m 9 ft 9 in.	10.34 m 33 ft 10 in.	12.4
40900 kg 90169 lb	6.0	-1.1	2.06 m 6 ft 9 in.	2.59 m 8 ft 6 in.	2.60 m 8 ft 6 in.	1.59 m 5 ft 3 in.	0.51 m 1 ft 8 in.	5.13 m 16 ft 10 in.	3.27 m 10 ft 9 in.	2.02 m 6 ft 7 in.	3.07 m 10 ft	3.07 m 10 ft	10.47 m 34 ft 4 in.	12.9
40900 kg 90169 lb	29.0	-0.8	2.15 m 7 ft 2 in.	2.65 m 8 ft 8 in.	2.66 m 8 ft 9 in.	1.63 m 5 ft 4 in.	0.52 m 1 ft 9 in.	5.09 m 16 ft 8 in.	3.27 m 10 ft 9 in.	1.97 m 6 ft 5 in.	3.00 m 9 ft 10 in.	3.00 m 9 ft 10 in.	10.36 m 33 ft 11 in.	12.5

EFFECTIVITY: ALL



## **2.4. INTERIOR ARRANGEMENTS**

The interior arrangement provides accommodation for two pilots, one observer, three flight attendants, and 98 passengers in 32 in pitch standard configuration. One additional flight attendant seat is available as an option.

### **2.4.1. Passenger Cabin**

The passenger cabin accommodates 98 passengers in 24 double seats on both sides, in 32 in pitch standard configuration.

As an option, the passenger cabin is also provided with some double first-class seats on the RH side and some single first-class seats on the LH side.

The main dimensions of passenger cabin are presented below:

- Height - 2.00 m (6 ft 7 in.)
- Width - 2.74 m (9 ft)
- Aisle wide - 0.49 m (1 ft 7 in.)
- Pitch - 0.82 m (32 in.)



# EMBRAER 190 AIRPORT PLANNING MANUAL

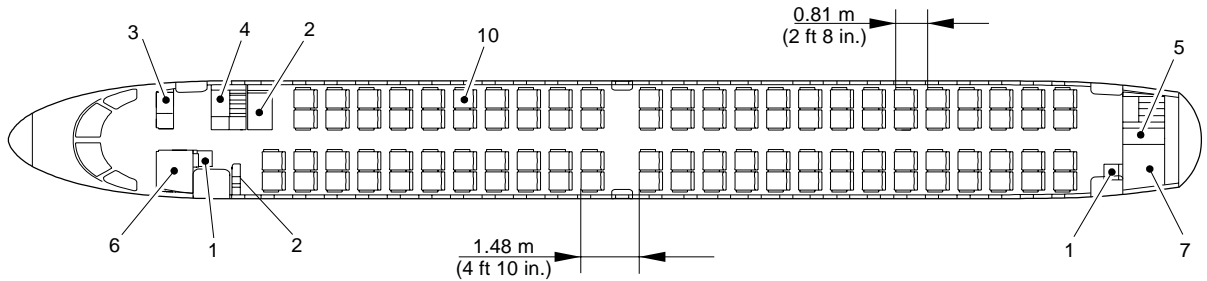
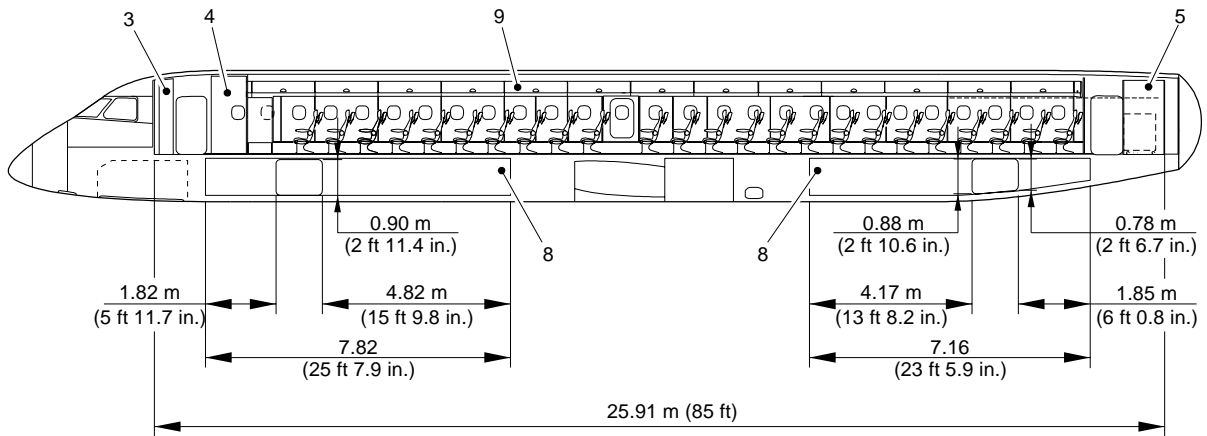

- 1 – FLIGHT ATTENDANT SEAT
- 2 – WARDROBE
- 3 – FWD RH G1 GALLEY
- 4 – FWD RH G2 GALLEY
- 5 – AFT RH GALLEY
- 6 – FWD LAVATORY
- 7 – AFT LAVATORY
- 8 – CARGO COMPARTMENT
- 9 – OVERHEAD BIN
- 10 – PASSENGER SEAT

CARGO/BAGGAGE VOLUME	
CARGO COMPARTMENT	22.63 m <sup>3</sup> (799.18 ft <sup>3</sup> )
OVERHEAD BIN	0.06 m <sup>3</sup> / pax (2.0 ft <sup>3</sup> / pax)
UNDERSEAT VOLUME	0.04 m <sup>3</sup> / pax (1.4 ft <sup>3</sup> / pax)

Typical Interior Arrangements  
Figure 2.4

EFFECTIVITY: ALL



## 2.4.2. Cargo Compartments

Two cargo compartments are available, located underfloor, one forward of the wing, and another aft of the wing.

The cargo compartments comply with the FAR-25/JAR-25/RBHA-25 “class C” compartment classification.

The table below contain the capacity for the cargo compartment:

Table 2.5 - Capacity for the Cargo Compartment

CARGO COMPARTMENT	LOADING	VOLUME
FWD <sup>[1]</sup>	1850 kg (4078 lb)	12.41 m <sup>3</sup> (438.26 ft <sup>3</sup> )
Aft	1650 kg (3638 lb)	10.22 m <sup>3</sup> (360.92 ft <sup>3</sup> )
Total	3500 kg (7716 lb)	22.63 m <sup>3</sup> (799.18 ft <sup>3</sup> )

1. Standard configuration (loading and volume may vary according to optional equipment installed).

The cargo compartments are provided with the following features:

- Optional vertical nets - to avoid damage due to cargo shifting (two for each cargo compartments). Also, there are provisions for two extra vertical nets in the forward cargo compartment and one in the aft cargo compartment;
- Door net at each cargo door.

## 2.4.3. Cockpit

The cockpit is acoustically and thermally insulated for appearance and durability. It follows the worldwide trend of rounded edges, which avoids harm to the flight crew.

The cockpit is separated from the passenger cabin by a bulkhead with a lockable door. The cockpit door is provided with lockable means operable only from the cockpit side, spy hole and escape mechanism on the cockpit side.





**2.5. PASSENGER CABIN CROSS SECTION**

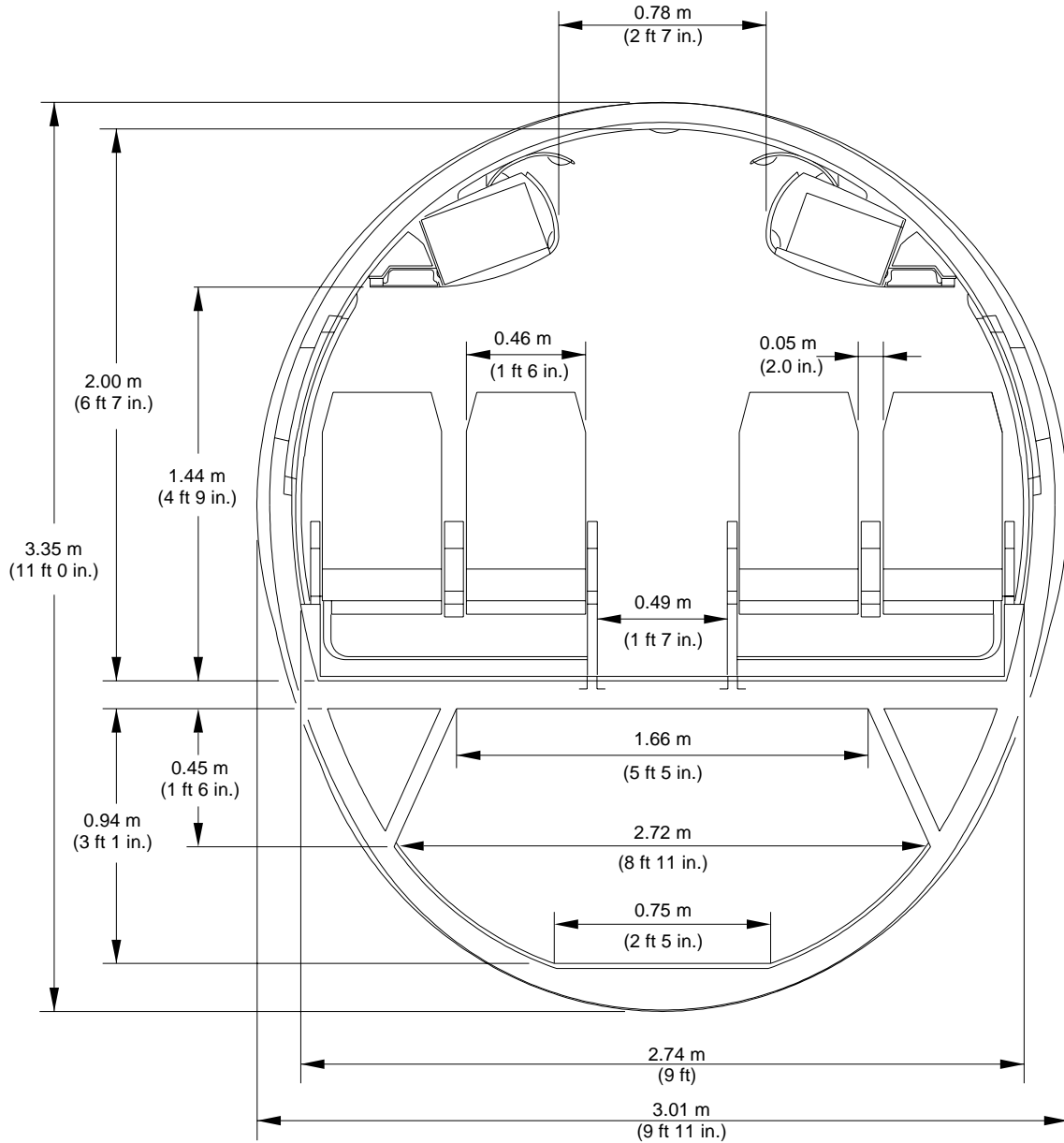

EM170APM020001A.DGN

Economy Class Passenger Cabin Cross-Section  
Figure 2.5

EFFECTIVITY: ALL



# EMBRAER 190 AIRPORT PLANNING MANUAL

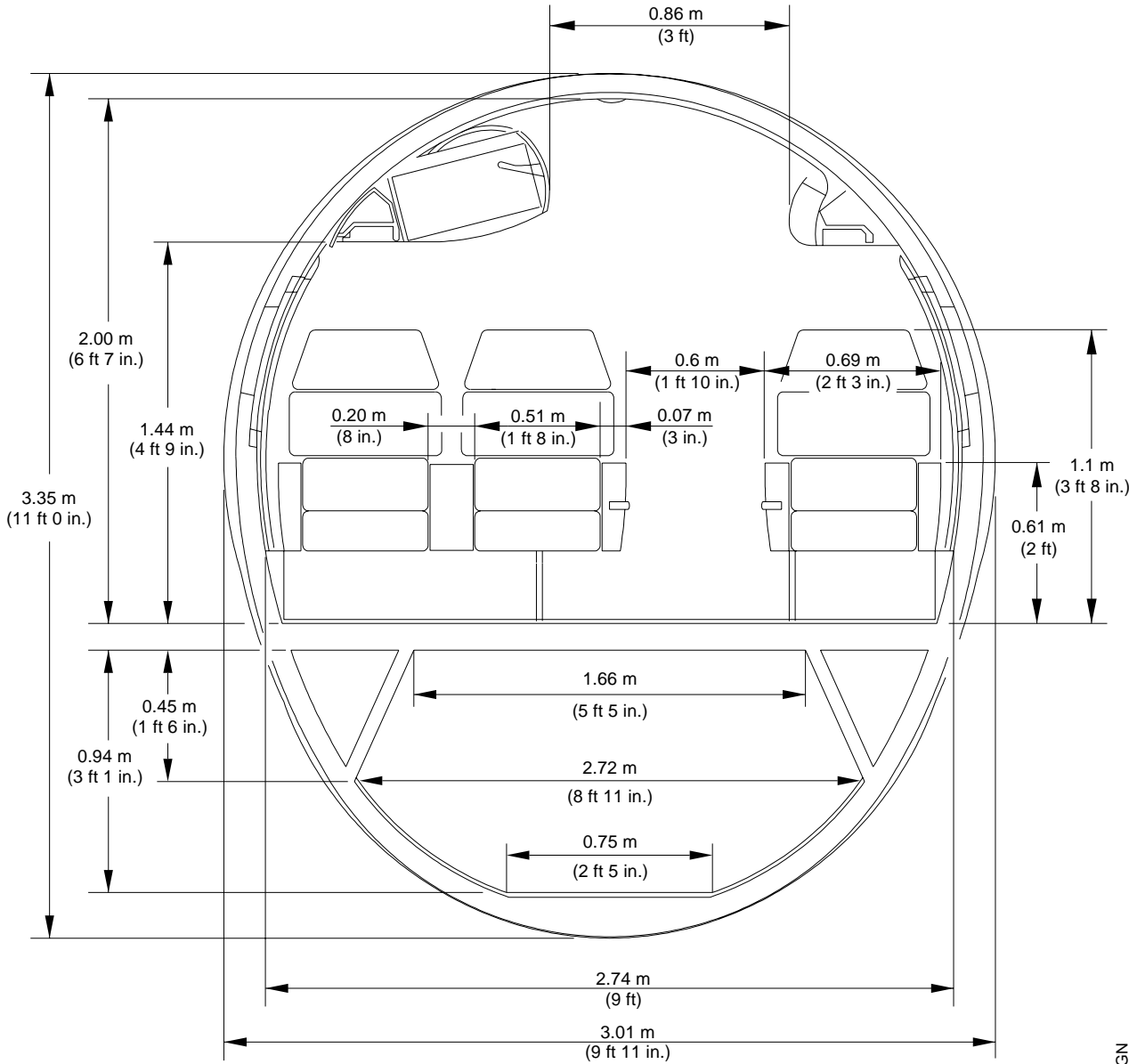

EM170APM020002A.DGN

First Class Passenger Cabin Cross-Section  
Figure 2.6

EFFECTIVITY: ALL



2.6. LOWER COMPARTMENT CONTAINERS

Not Applicable

EFFECTIVITY: ALL



# EMBRAER 190 AIRPORT PLANNING MANUAL

## 2.7. DOOR CLEARANCES

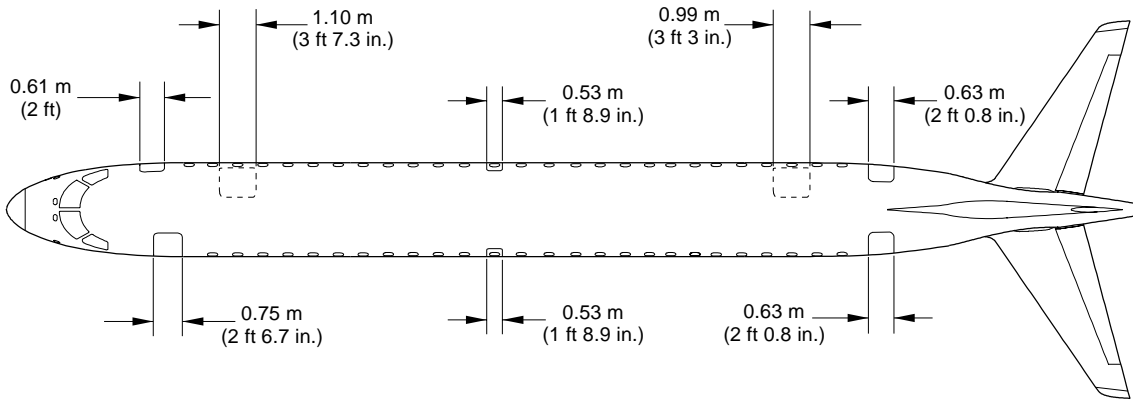
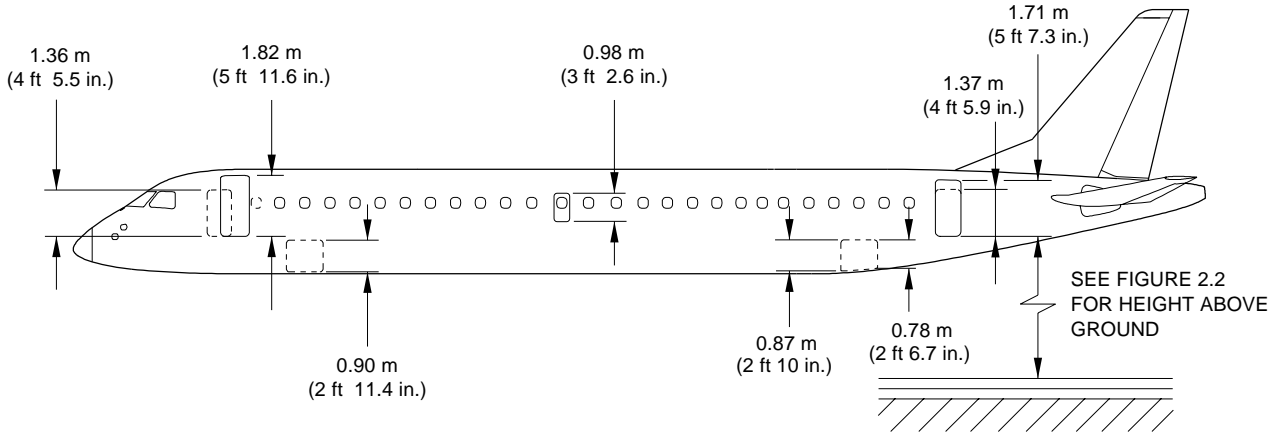

**NOTE:** FOR DIMENSIONS OF ALL DOORS, CONSIDER THAT AIRCRAFT IS IN OPERATION, THAT IS, EQUIPPED WITH DOOR LININGS AND DOOR SURROUNDS.

EM170APM020014C.DGN

Door Dimensions  
Figure 2.7

EFFECTIVITY: ALL



### 3. AIRCRAFT PERFORMANCE

#### 3.1. GENERAL INFORMATION

The performance of the aircraft and engine depends on the generation of forces by the interaction between the aircraft or engine and the air mass through which it flies. The atmosphere has a pronounced effect on the temperature, pressure and density of the air.

The ICAO establishes standard basics for estimating and comparing aircraft and engine performance. Some ICAO standard basics are shown below:

1. Sea level standard day:  
 Standard Temperature  $T_0 = 15\text{ }^{\circ}\text{C}$  (288.15 K)  
 Standard Pressure  $P_0 = 101.3\text{ kPa}$  (29.92 inHg)  
 Standard Density  $\rho_0 = 0.002377\text{ slug per cubic feet}$
2. ISA

Table 3.1 - ISA

ALTITUDE		TEMPERATURE	
m	ft	$^{\circ}\text{C}$	$^{\circ}\text{F}$
0	0	15.0	59.0
305	1000	13.0	55.4
610	2000	11.0	51.9
915	3000	9.1	48.3
1220	4000	7.1	44.7
1524	5000	5.1	41.2
3049	10000	-4.8	23.3
4573	15000	-14.7	5.5
6098	20000	-24.6	-12.3
7622	25000	-34.5	-30.2
9146	30000	-44.4	-48.0
11003	36089	-56.5	-69.7
12195	40000	-56.5	-69.7

NOTE: The performance data shown in this section must not be used for operations.

NOTE: For further information about performance, refer to AOM and AFM.

Tire speed limits are not applicable to this specific aircraft.  
 This section provides the following information:

- The payload x range charts.
- The takeoff field length charts.
- The landing field length charts.

NOTE: For other charts containing payload x ranges, takeoff field lengths and/or landing field lengths with conditions different from those presented in this section, Embraer should be contacted so that these charts can be obtained.

EFFECTIVITY: ALL



### 3.2. PAYLOAD X RANGE

The Payload x Range charts are based on the following conditions:

- CF34 - 10E engine models;
- Aircraft carrying passengers at 100 kg (220 lb) each one;
- Flight level 350, that represents the cruising altitude equal to 10668 m (35000 ft);
- Atmosphere according to ISA or ISA + 10 °C conditions;
- MTOW.



# EMBRAER 190 AIRPORT PLANNING MANUAL

**PAYLOAD VS RANGE**  
 CF34 -10E5A, -10E5A1, -10E6A, -10E6A1 & -10E7 ENGINES  
 FLIGHT LEVEL 370  
 ISA  
 RESERVE : 100 nm ALTERNATE + 45 min FLIGHT  
 MTOW = 47790 kg (105359 lb)

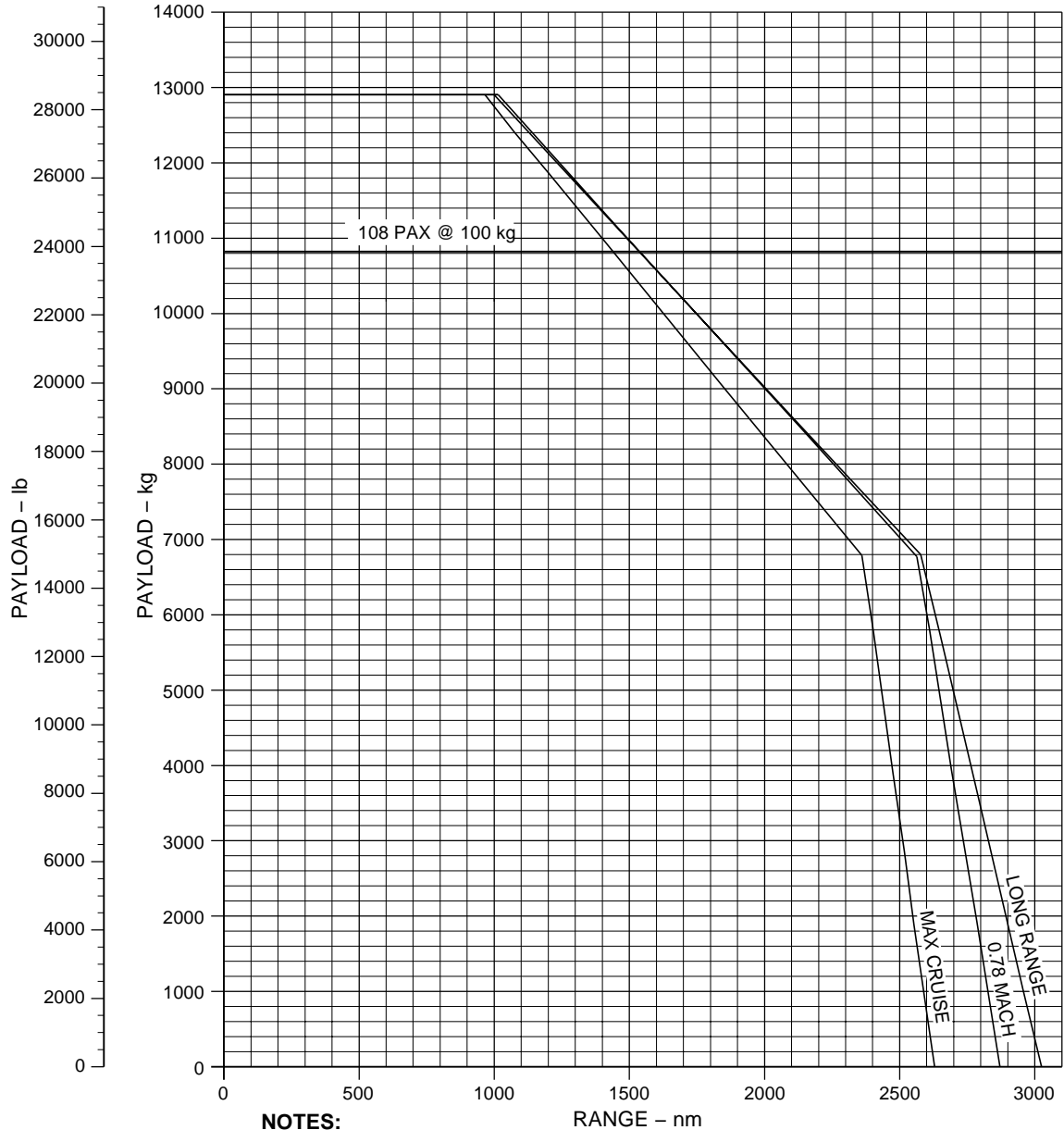
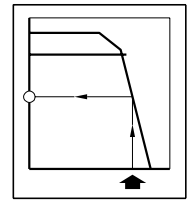

- NOTES:**
- MAX TAKEOFF WEIGHT - - - - - 47790 kg (105359 lb)
  - MAX ZERO FUEL WEIGHT - - - - - 40800 kg (89948 lb)
  - BASIC OPERATING WEIGHT - - - - - 27900 kg (61509 lb)
  - MAX USABLE FUEL - - - - - 13100 kg (28880 lb)

EM170APM030030E.DGN

Payload x Range - ISA Conditions  
 Figure 3.1

EFFECTIVITY: EMBRAER 190 STD ACFT MODEL



# EMBRAER 190 AIRPORT PLANNING MANUAL

**PAYLOAD VS RANGE**  
 CF34 -10E5A, -10E5A1, -10E6A, -10E6A1 & -10E7 ENGINES  
 FLIGHT LEVEL 370  
 ISA + 10°C  
 RESERVE : 100 nm ALTERNATE + 45 min FLIGHT  
 MTOW = 47790 kg (105359 lb)

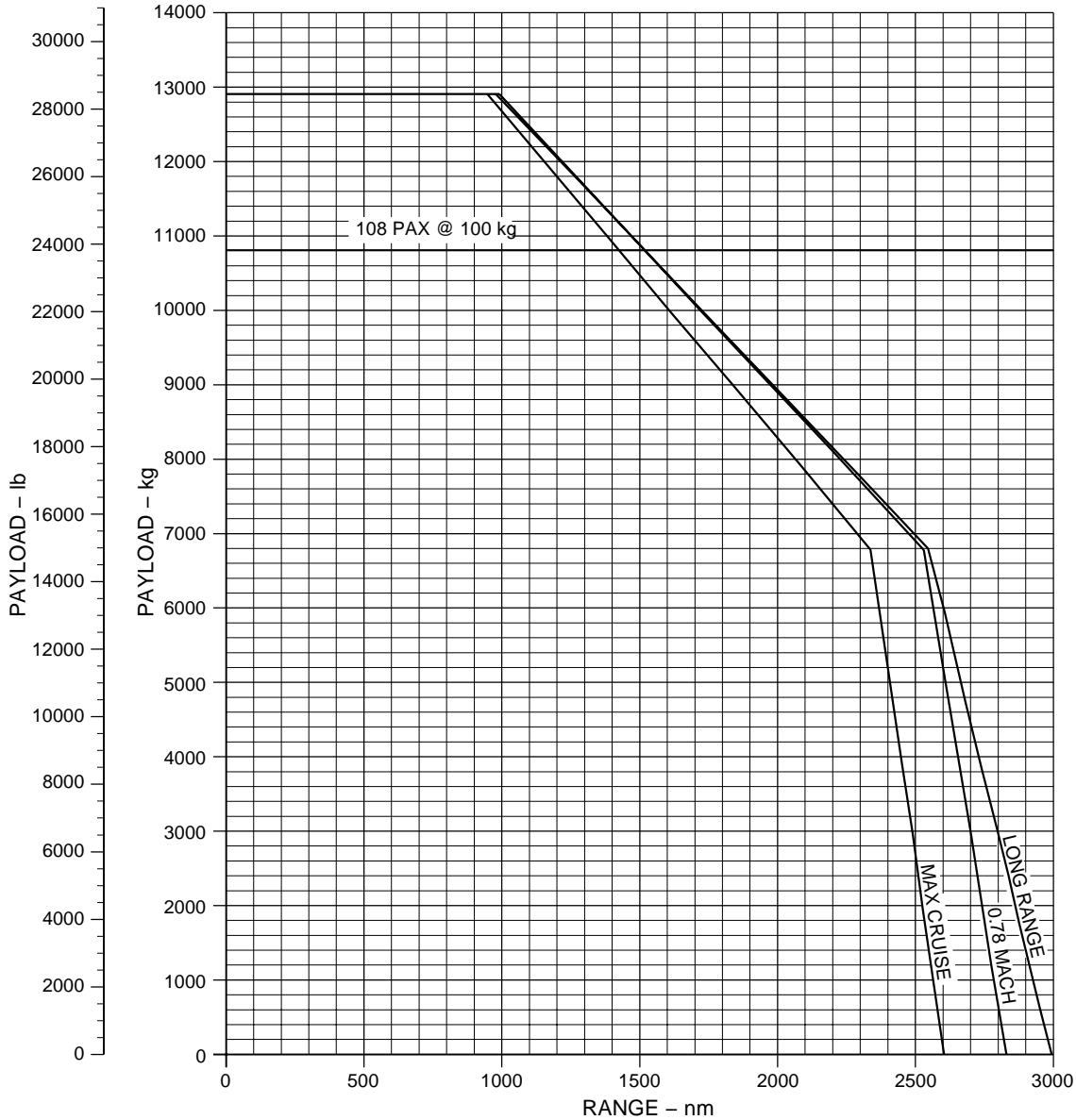
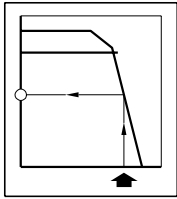

- NOTES:**
- MAX TAKEOFF WEIGHT - - - - - 47790 kg (105359 lb)
  - MAX ZERO FUEL WEIGHT - - - - - 40800 kg (89948 lb)
  - BASIC OPERATING WEIGHT - - - - - 27900 kg (61509 lb)
  - MAX USABLE FUEL - - - - - 13100 kg (28880 lb)

Payload x Range - ISA + 10 °C Conditions  
 Figure 3.2

EM170APM030031E.DGN

EFFECTIVITY: EMBRAER 190 STD ACFT MODEL





# EMBRAER 190 AIRPORT PLANNING MANUAL

**PAYLOAD VS RANGE**  
 CF34 -10E5A, -10E5A1, -10E6A, -10E6A1 & -10E7 ENGINES  
 FLIGHT LEVEL 370  
 ISA  
 RESERVE : 100 nm ALTERNATE + 45 min FLIGHT  
 MTOW = 50300 kg (110893 lb)

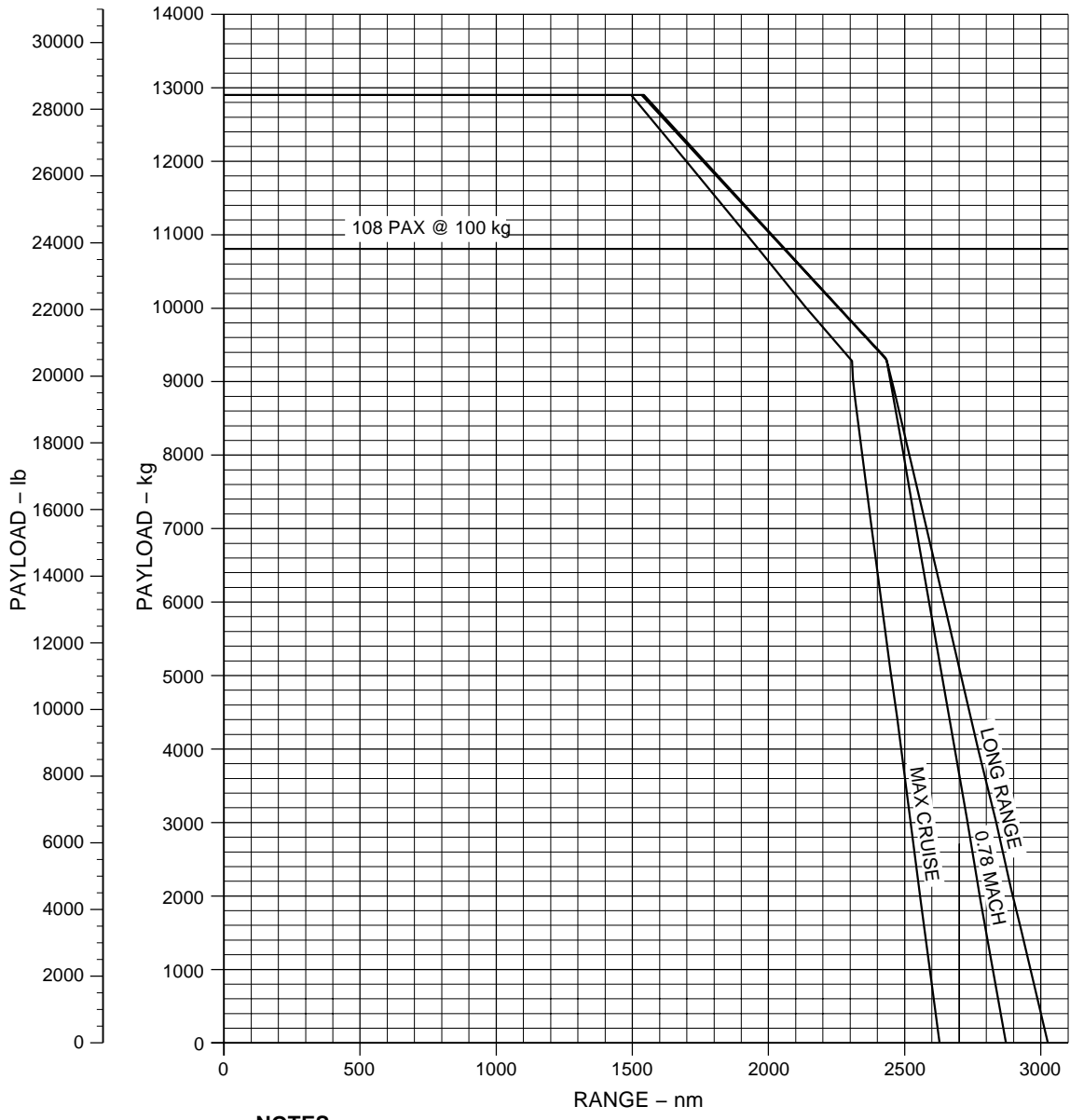
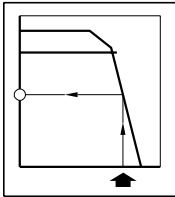

**NOTES:**  
 MAX TAKEOFF WEIGHT - - - - - 50300 kg (110893 lb)  
 MAX ZERO FUEL WEIGHT - - - - - 40800 kg (89949 lb)  
 BASIC OPERATING WEIGHT - - - - - 27900 kg (61509 lb)  
 MAX USABLE FUEL - - - - - 13100 kg (28880 lb)

Payload x Range - ISA Conditions  
 Figure 3.3

EM170APM030032D.DGN

EFFECTIVITY: EMBRAER 190 LR ACFT MODEL



# EMBRAER 190 AIRPORT PLANNING MANUAL

**PAYLOAD VS RANGE**  
 CF34 -10E5A, -10E5A1, -10E6A, -10E6A1 & -10E7 ENGINES  
 FLIGHT LEVEL 370  
 ISA + 10°C  
 RESERVE : 100 nm ALTERNATE + 45 min FLIGHT  
 MTOW = 50300 kg (110893 lb)

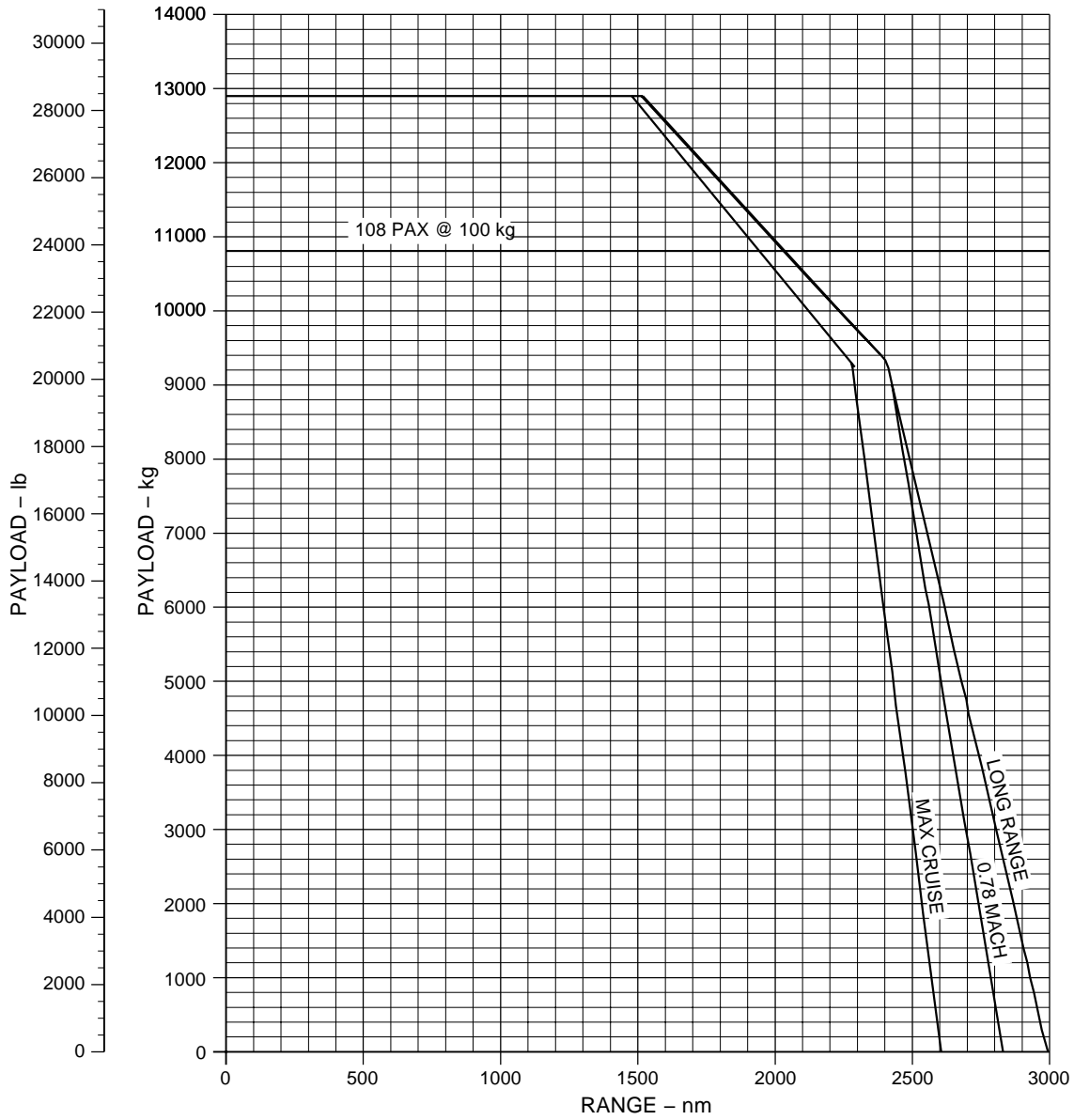
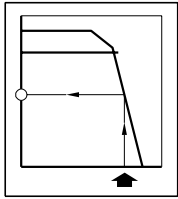

- NOTES:**
- MAX TAKEOFF WEIGHT - - - - - 50300 kg (110893 lb)
  - MAX ZERO FUEL WEIGHT - - - - - 40800 kg (89949 lb)
  - BASIC OPERATING WEIGHT - - - - - 27900 kg (61509 lb)
  - MAX USABLE FUEL - - - - - 13100 kg (28880 lb)

Payload x Range - ISA + 10 °C Conditions  
 Figure 3.4

EM170APM030033D.DGN

EFFECTIVITY: EMBRAER 190 LR ACFT MODEL



# EMBRAER 190 AIRPORT PLANNING MANUAL

**PAYLOAD VS RANGE**  
 CF34 -10E5A, -10E5A1, -10E6A, -10E6A1 & -10E7 ENGINES  
 FLIGHT LEVEL 370  
 ISA  
 RESERVE : 100 nm ALTERNATE + 45 min FLIGHT  
 MTOW = 51800 kg (114199 lb)

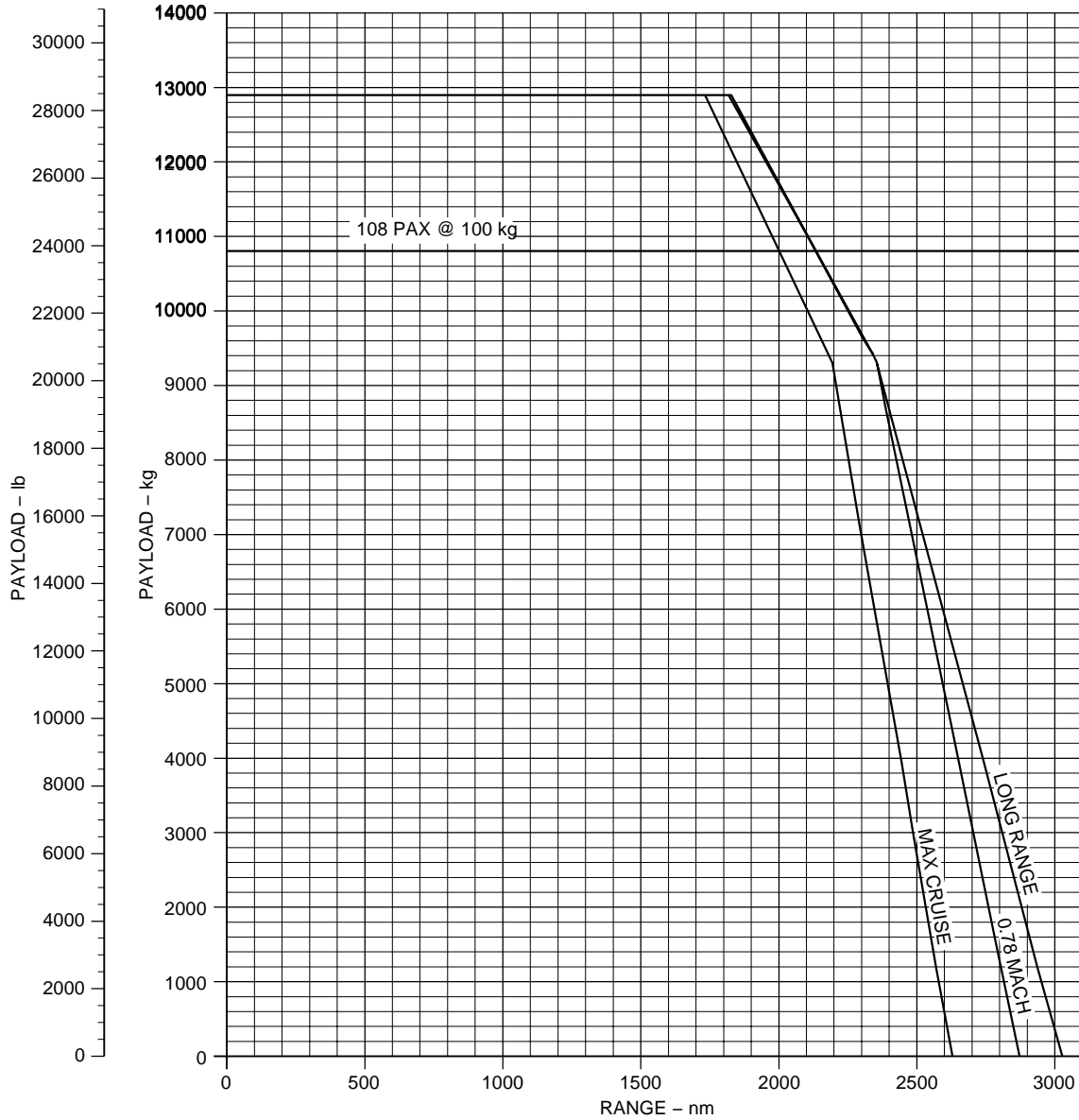
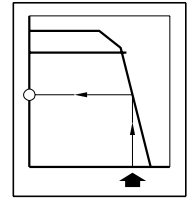

- NOTES:**
- MAX TAKEOFF WEIGHT - - - - - 51800 kg (114199 lb)
  - MAX ZERO FUEL WEIGHT - - - - - 40900 kg (90169 lb)
  - BASIC OPERATING WEIGHT - - - - - 27900 kg (61509 lb)
  - MAX USABLE FUEL - - - - - 13100 kg (28880 lb)

Payload x Range - ISA Conditions  
 Figure 3.5

EM170APM030060C.DGN

EFFECTIVITY: EMBRAER 190 AR ACFT MODEL



# EMBRAER 190 AIRPORT PLANNING MANUAL

**PAYLOAD VS RANGE**  
 CF34 -10E5A, -10E5A1, -10E6A, -10E6A1 & -10E7 ENGINES  
 FLIGHT LEVEL 370  
 ISA+10  
 RESERVE : 100 nm ALTERNATE + 45 min FLIGHT  
 MTOW = 51800 kg (114199 lb)

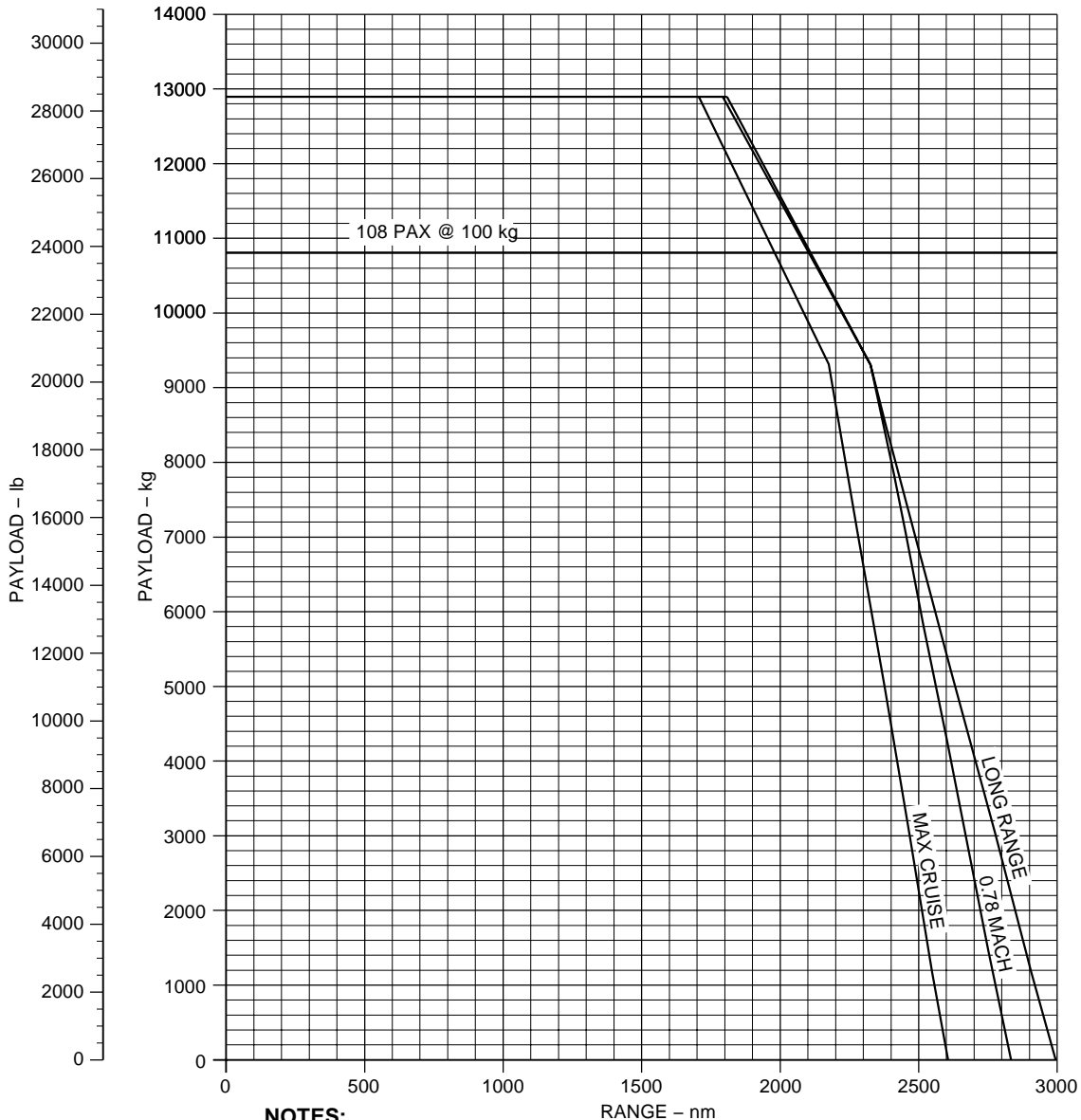
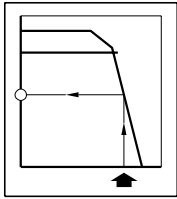

**NOTES:**  
 MAX TAKEOFF WEIGHT - - - - - 51800 kg (114199 lb)  
 MAX ZERO FUEL WEIGHT - - - - - 40900 kg (90169 lb)  
 BASIC OPERATING WEIGHT - - - - - 27900 kg (61509 lb)  
 MAX USABLE FUEL - - - - - 13100 kg (28880 lb)

EM170APM030061C.DGN

Payload x Range - ISA + 10 °C Conditions  
 Figure 3.6

EFFECTIVITY: EMBRAER 190 AR ACFT MODEL



### **3.3. TAKEOFF FIELD LENGTHS**

The takeoff performance is based on the requirements of JAR 25, Change 14, plus amendment 25/96/1. The takeoff field lengths charts provide data about the maximum takeoff weights for compliance with the operating regulations relating to takeoff field lengths.

Data are presented according to the following associated conditions:

- CF34 - 10E engine models;
- Takeoff Mode: 1;
- ATTCS positioning: ON and OFF;
- Flaps setting position: 1, 2 and 4;
- Pavement conditions: dry, hard paved and level runway surface with no obstacles;
- Zero wind and atmosphere according to ISA or ISA + 10 °C conditions;
- Pack OFF: No engine bleed extraction for air conditioning packs was considered in the takeoff and landing charts.



# EMBRAER 190 AIRPORT PLANNING MANUAL

**TAKEOFF FIELD LENGTH**  
 CF 34-10E5 & -10E6 ENGINE @ T/O-1 MODE  
 ATTCS OFF / ECS OFF  
 DRY, SMOOTH, HARD PAVED AND LEVEL RUNWAY  
 ISA

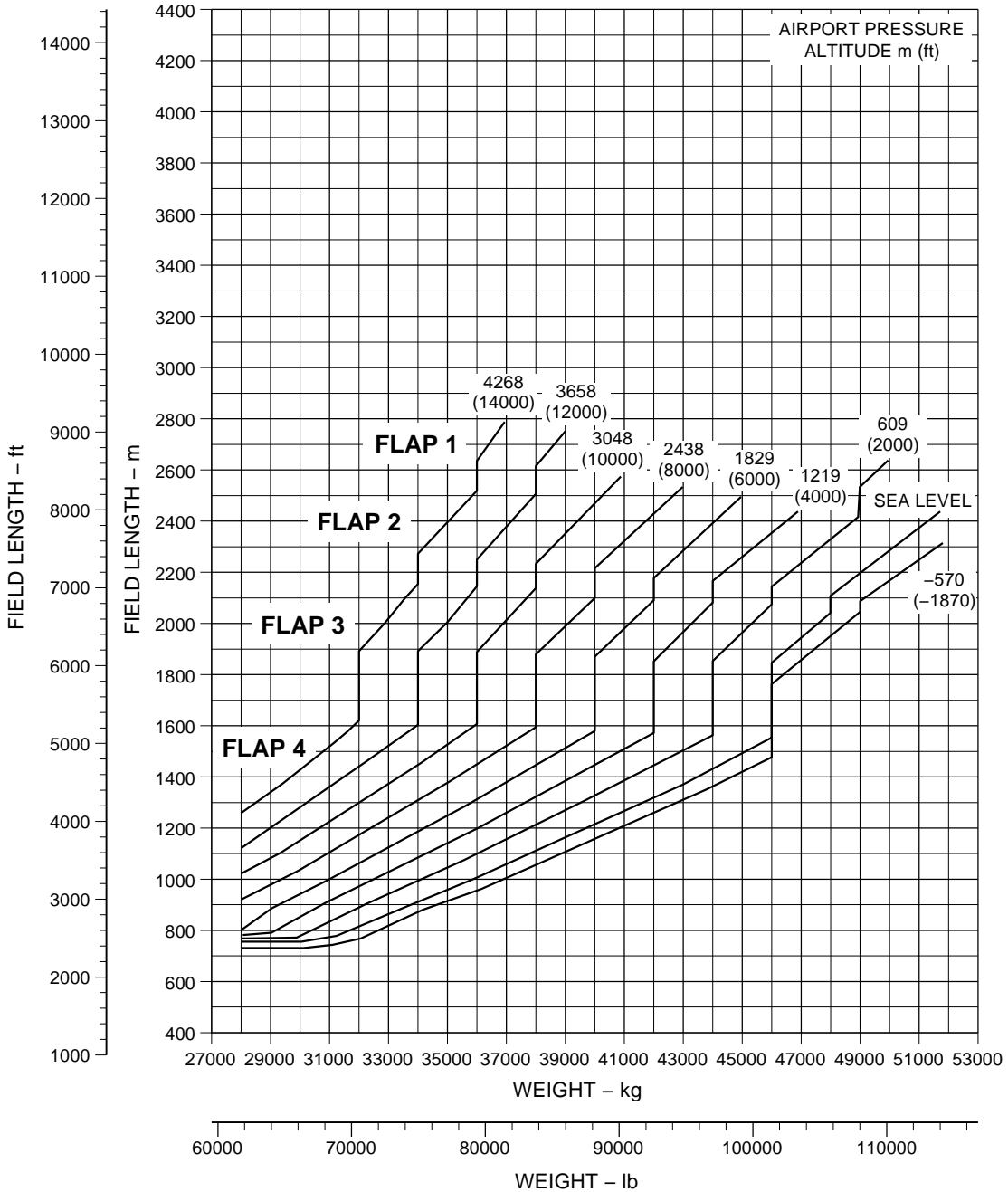
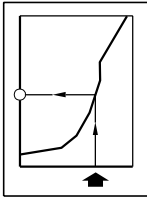

Takeoff Field Lengths - ISA Conditions  
 Figure 3.7

EM170APM030036E.DGN

EFFECTIVITY: ALL



# EMBRAER 190 AIRPORT PLANNING MANUAL

**TAKEOFF FIELD LENGTH**  
 CF34-10E5 & -10E6 Engines @ T/O-1 MODE  
 ATTCS OFF / ECS OFF  
 DRY, SMOOTH, HARD PAVED AND LEVEL RUNWAY  
 ISA + 15°C

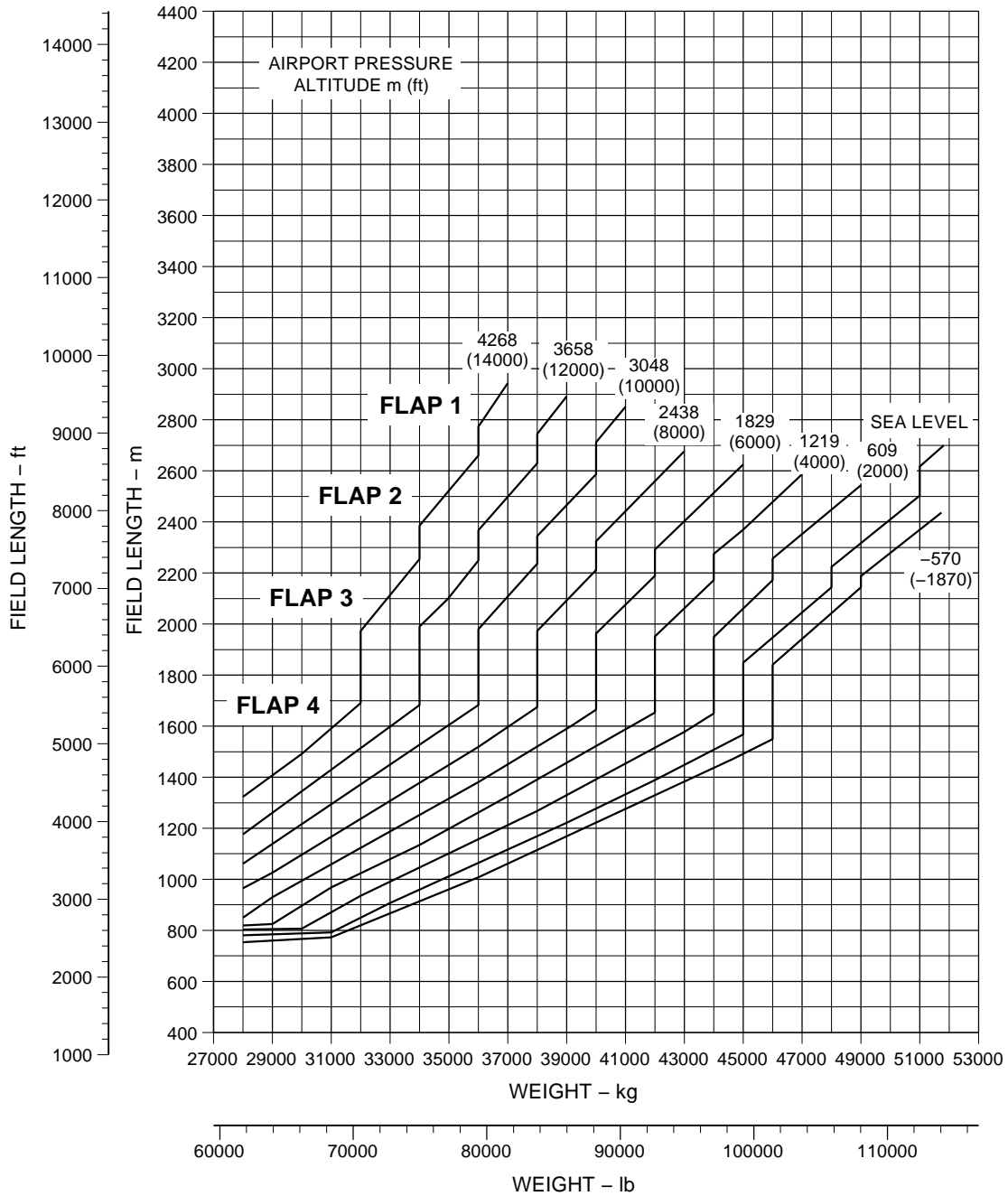
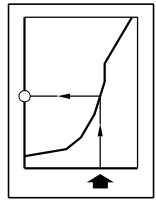

Takeoff Field Lengths - ISA + 15 °C Conditions  
 Figure 3.8

EM170APM030037E.DGN

EFFECTIVITY: ALL



# EMBRAER 190 AIRPORT PLANNING MANUAL

**TAKEOFF FIELD LENGTH**  
 CF34-10E5 & -10E6 Engines @ T/O-1 MODE  
 ATTCS ON / ECS OFF  
 DRY, SMOOTH, HARD PAVED AND LEVEL RUNWAY  
 ISA

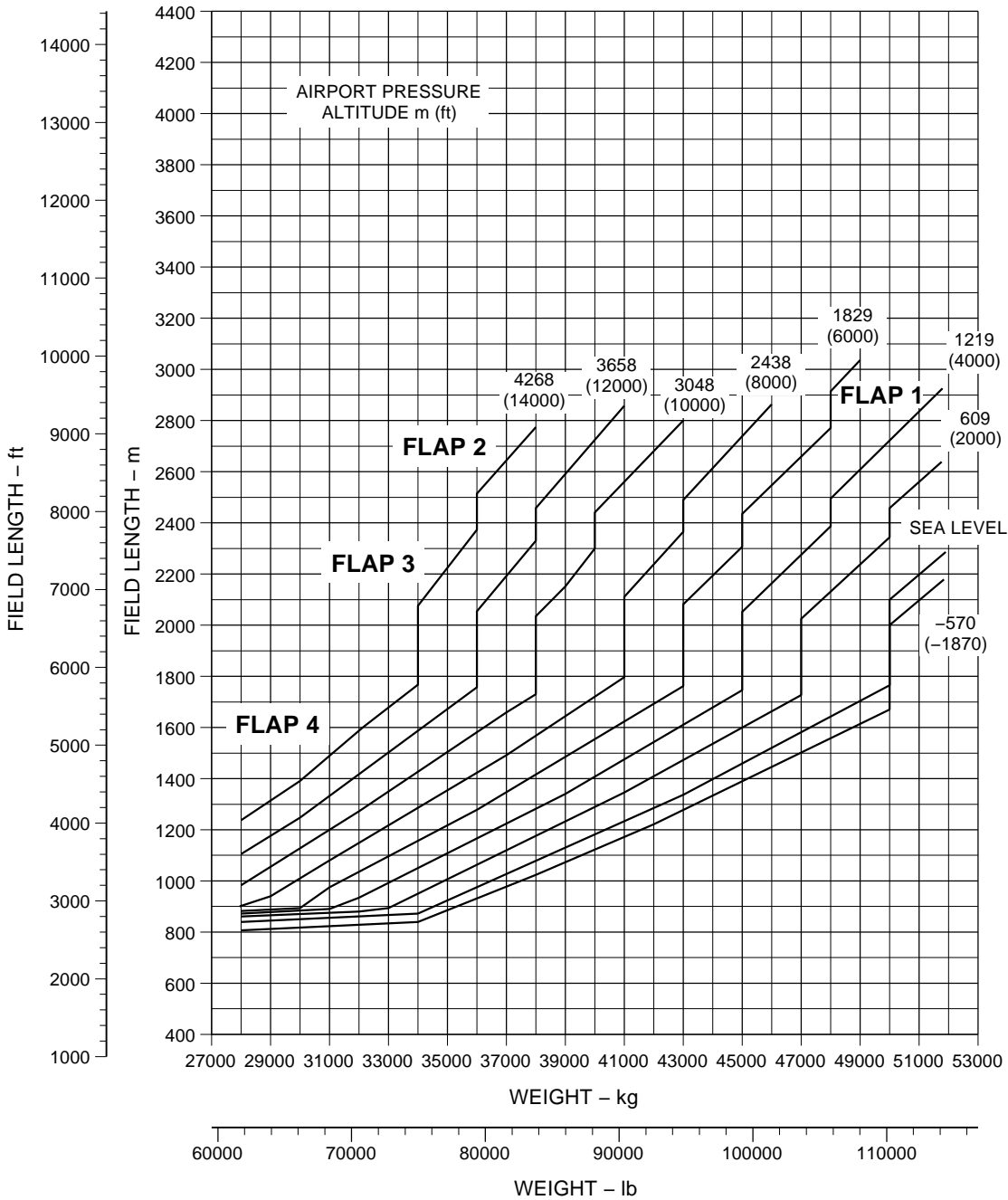
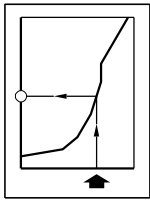

EM170APM030038E.DGN

Takeoff Field Lengths - ISA Conditions  
 Figure 3.9

EFFECTIVITY: ALL





# EMBRAER 190 AIRPORT PLANNING MANUAL

**TAKEOFF FIELD LENGTH**  
 CF34-10E5 & -10E6 Engines @ T/O-1 MODE  
 ATTCS ON / ECS OFF  
 DRY, SMOOTH, HARD PAVED AND LEVEL RUNWAY  
 ISA + 15°C

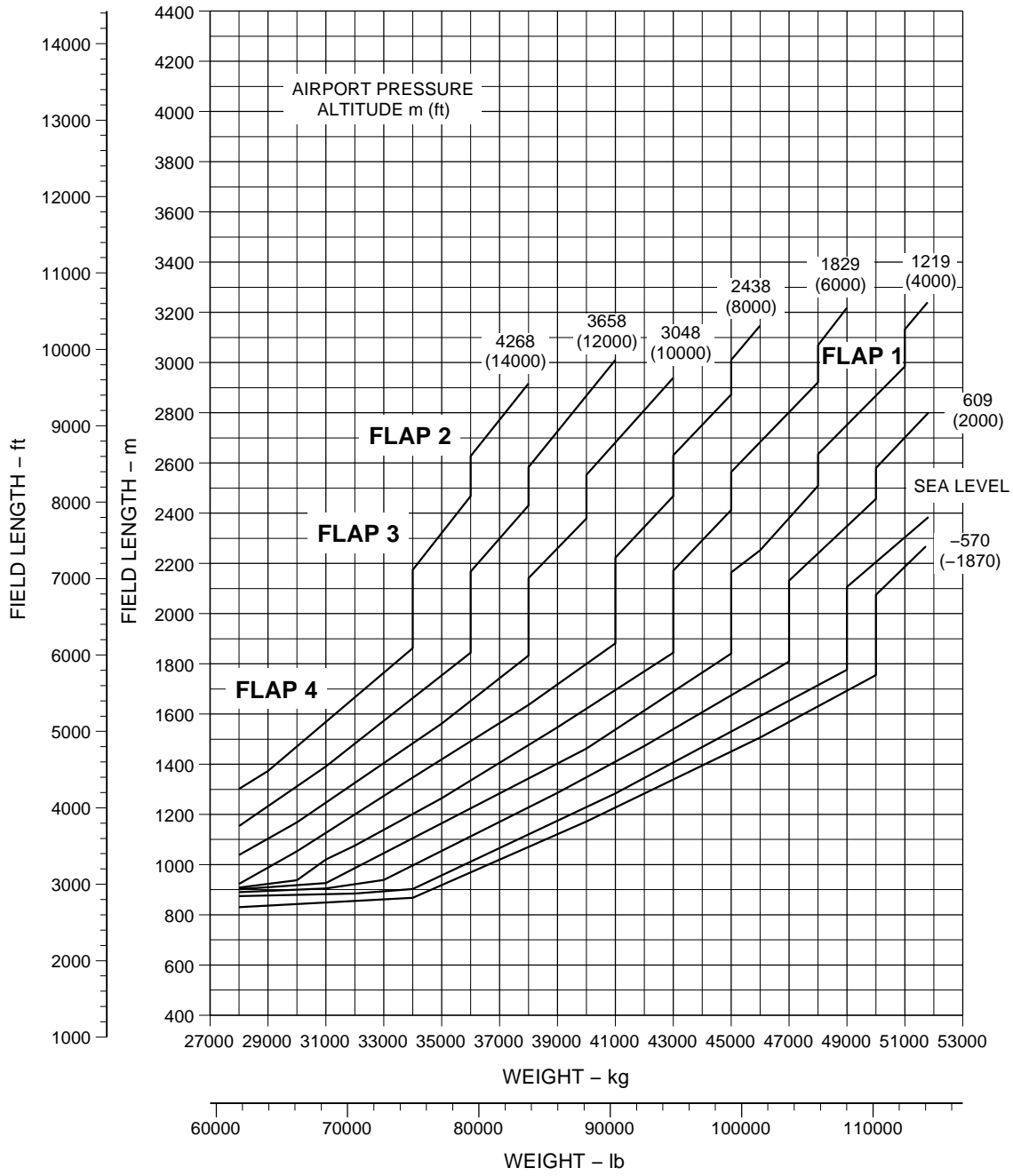
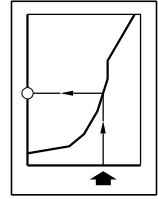

Takeoff Field Lengths - ISA + 15 °C Conditions  
 Figure 3.10

EFFECTIVITY: ALL

EM170APM030039E.DGN



# EMBRAER 190 AIRPORT PLANNING MANUAL

**TAKEOFF FIELD LENGTH**  
 CF34-10E5A1 & 10E6A1 ENGINES@T/O-1 MODE  
 DRY, SMOOTH, HARD PAVED AND LEVEL RUNWAY  
 ISA

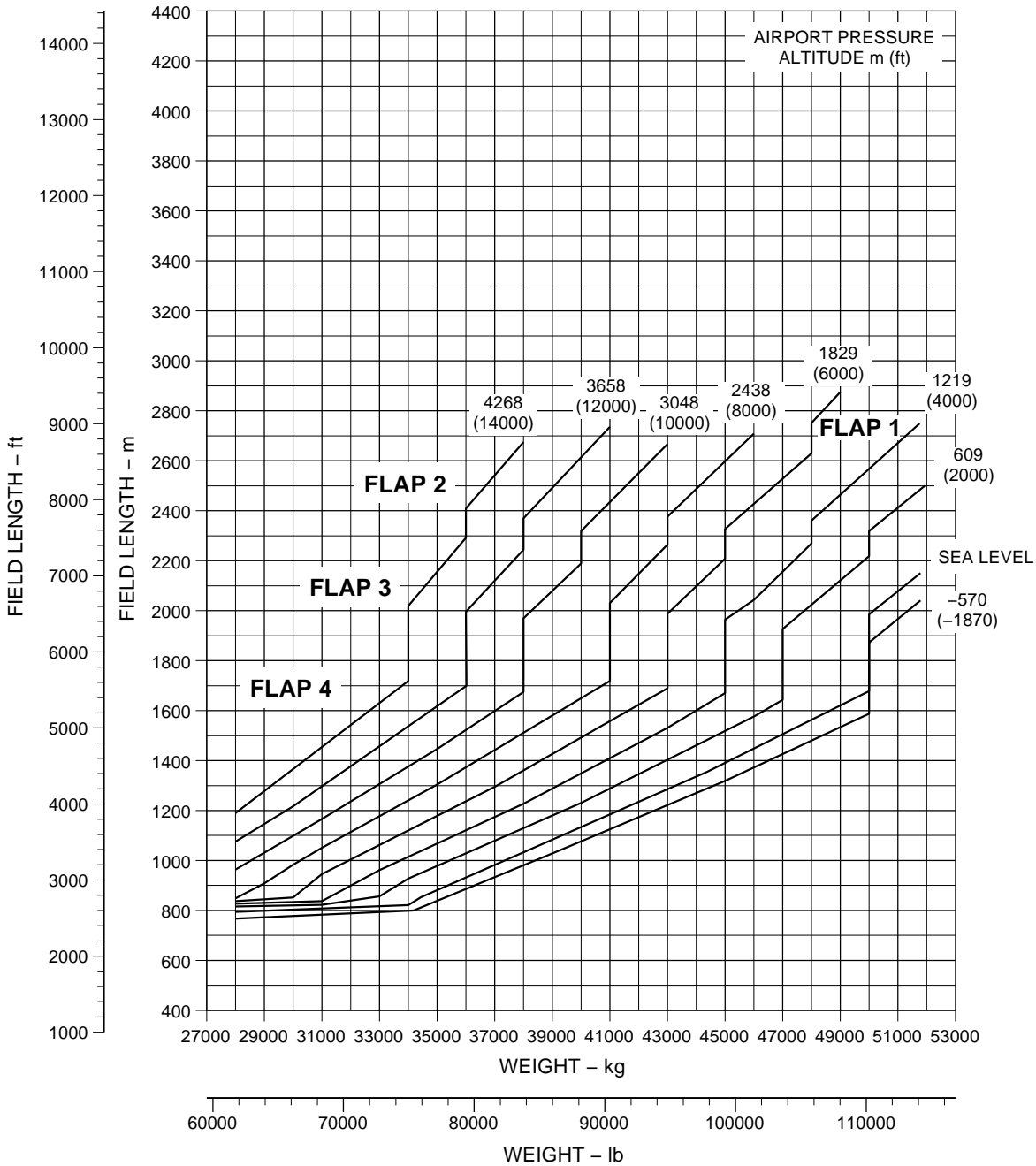
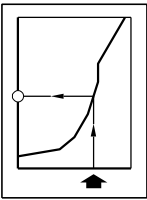

Takeoff Field Lengths - ISA Conditions  
 Figure 3.11

EM170APM030034D.DGN

EFFECTIVITY: ALL



# EMBRAER 190 AIRPORT PLANNING MANUAL

**TAKEOFF FIELD LENGTH**  
 CF34-10E5A1 & 10E6A1 ENGINES@T/O-1 MODE  
 DRY, SMOOTH, HARD PAVED AND LEVEL RUNWAY  
 ISA + 15°C

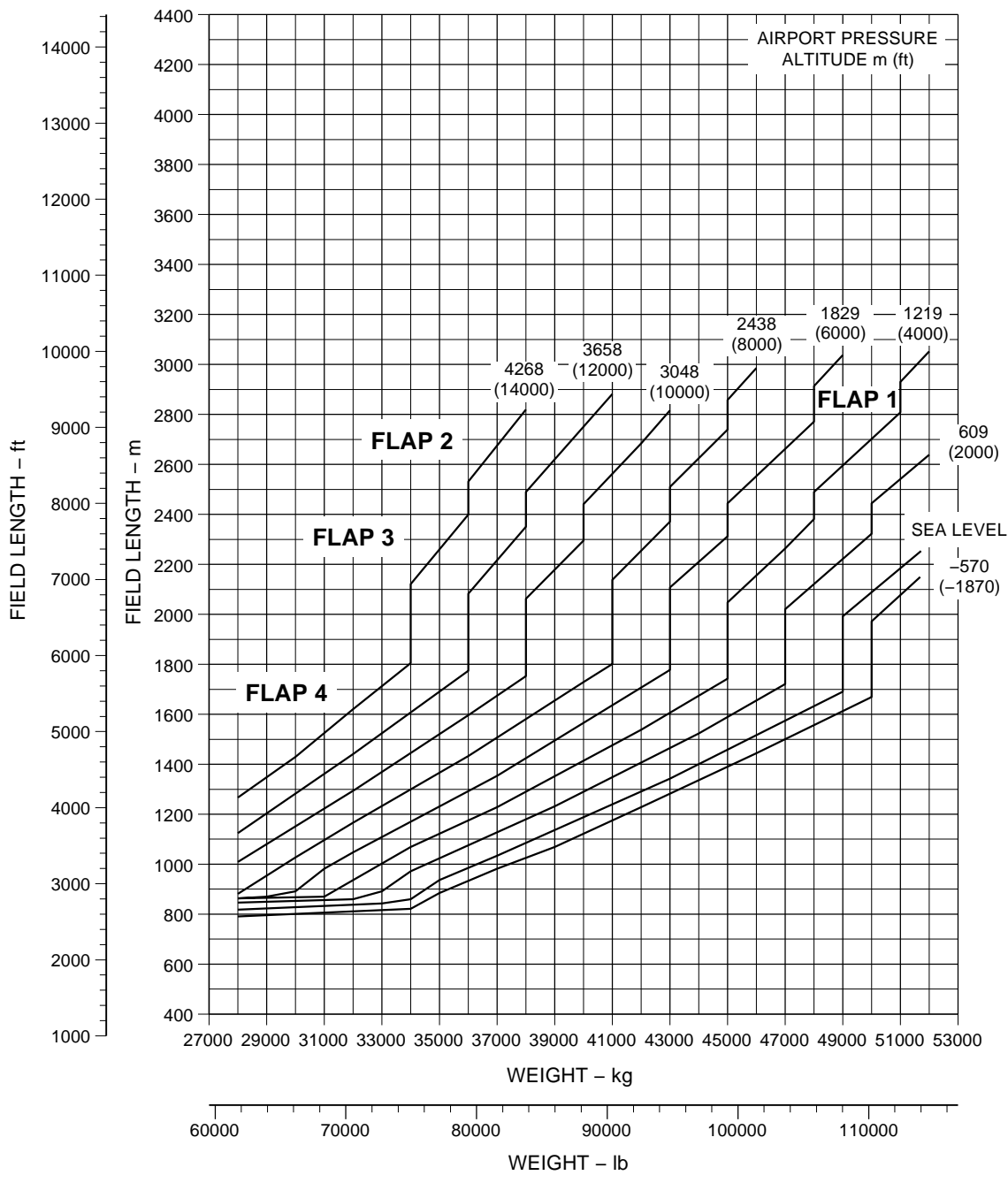
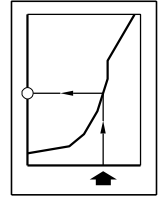

Takeoff Field Lengths - ISA + 15 °C Conditions  
 Figure 3.12

EFFECTIVITY: ALL

EM170APM030035D.DGN

w-apm1901



# EMBRAER 190 AIRPORT PLANNING MANUAL

**TAKEOFF FIELD LENGTH**  
 CF 34-10E7 ENGINE @ T/O-1 MODE  
 ATTCS ON / ECS OFF  
 DRY, SMOOTH, HARD PAVED AND LEVEL RUNWAY  
 ISA

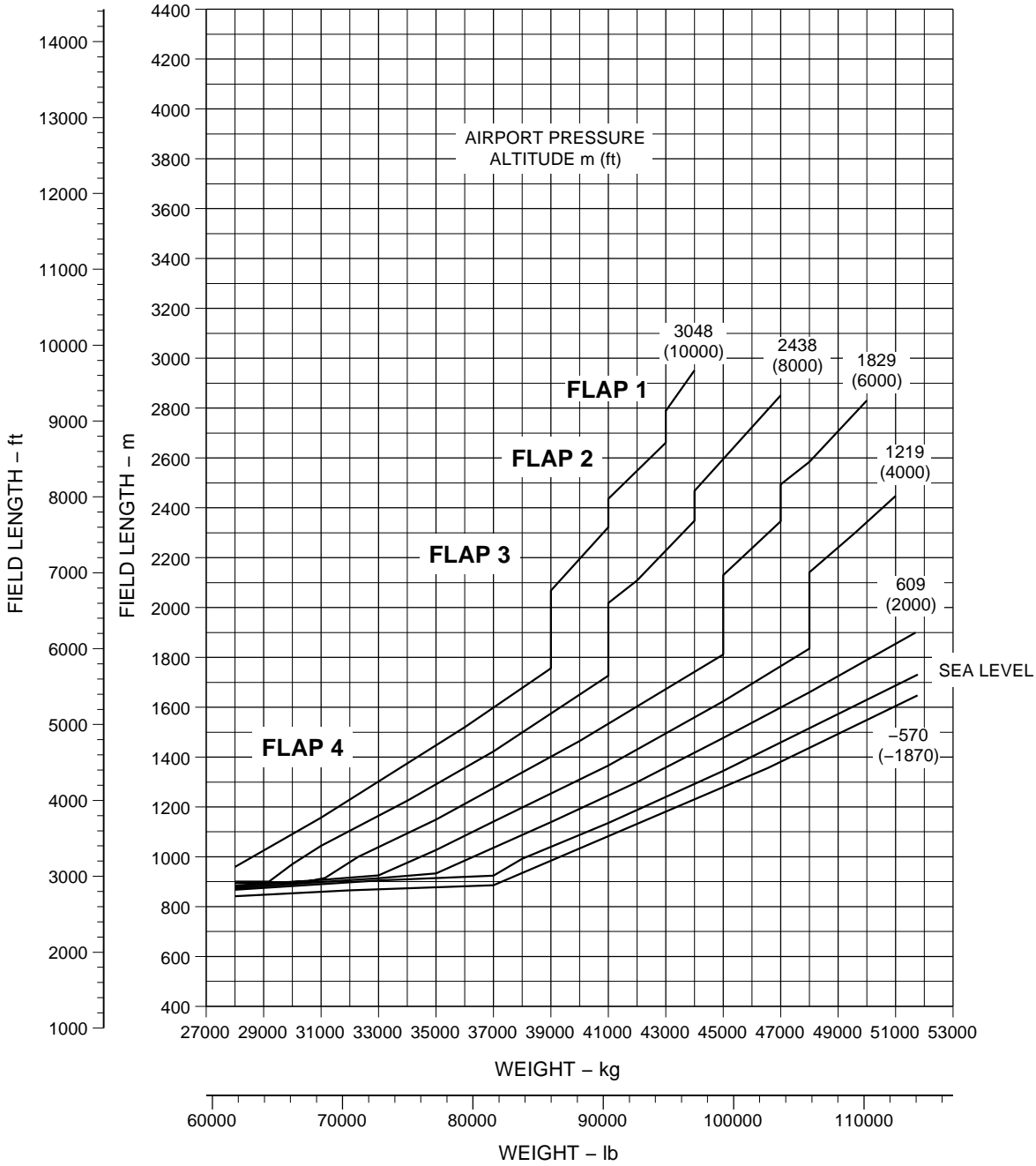
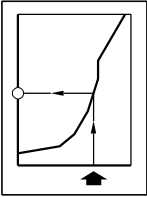

Takeoff Field Lengths - ISA Conditions  
 Figure 3.13

EM170APM030040D.DGN

EFFECTIVITY: ALL



# EMBRAER 190 AIRPORT PLANNING MANUAL

**TAKEOFF FIELD LENGTH**  
 CF 34-10E7 ENGINE @ T/O-1 MODE  
 ATTCS ON / ECS OFF  
 DRY, SMOOTH, HARD PAVED AND LEVEL RUNWAY  
 ISA + 15°C

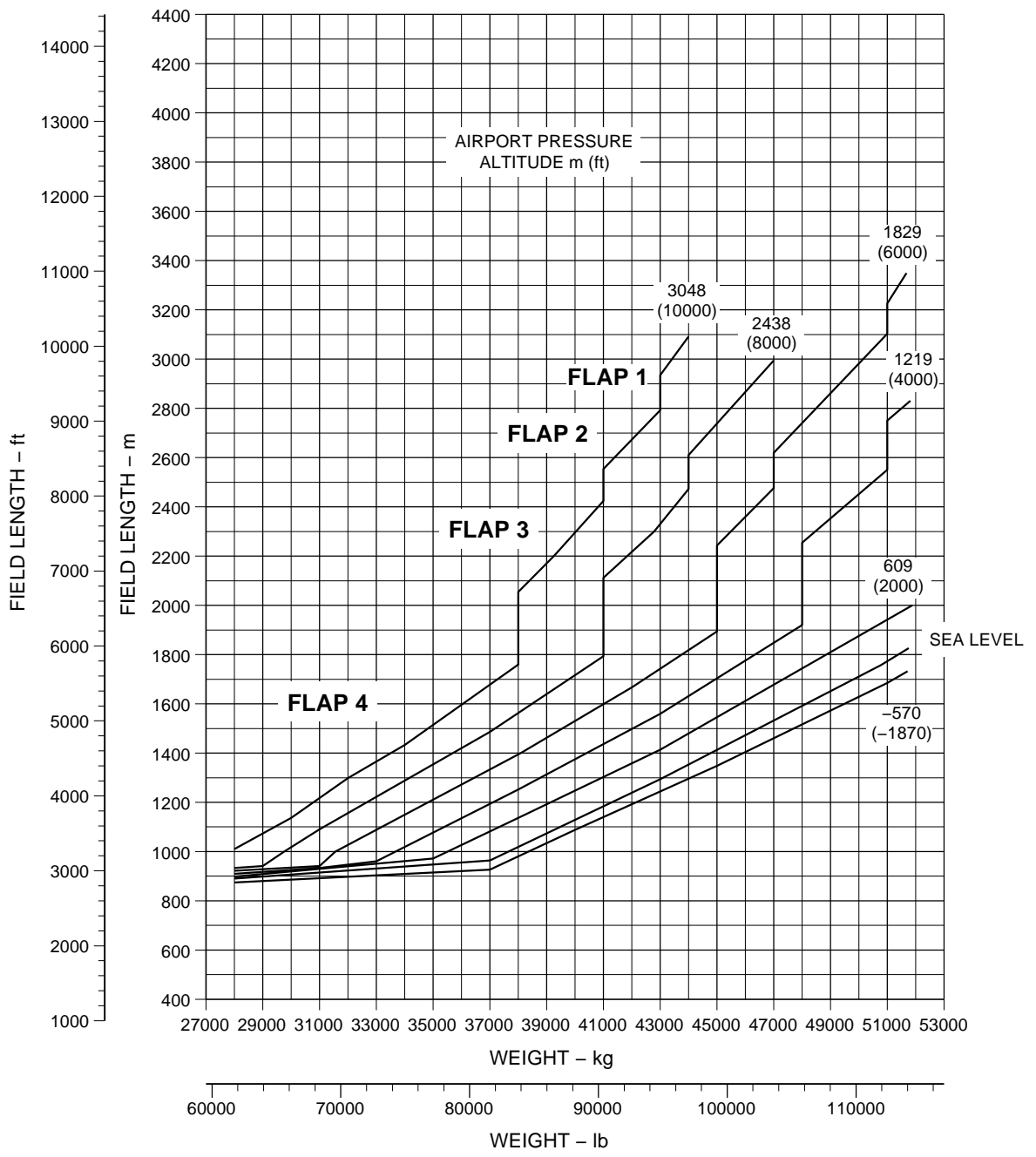
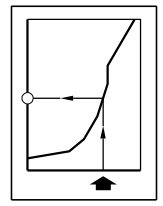

Takeoff Field Lengths - ISA + 15 °C Conditions  
 Figure 3.14

EFFECTIVITY: ALL



# EMBRAER 190 AIRPORT PLANNING MANUAL

**TAKEOFF FIELD LENGTH**  
 CF 34-10E7 ENGINE @ T/O-1 MODE  
 ATTCS OFF / ECS OFF  
 DRY, SMOOTH, HARD PAVED AND LEVEL RUNWAY  
 ISA

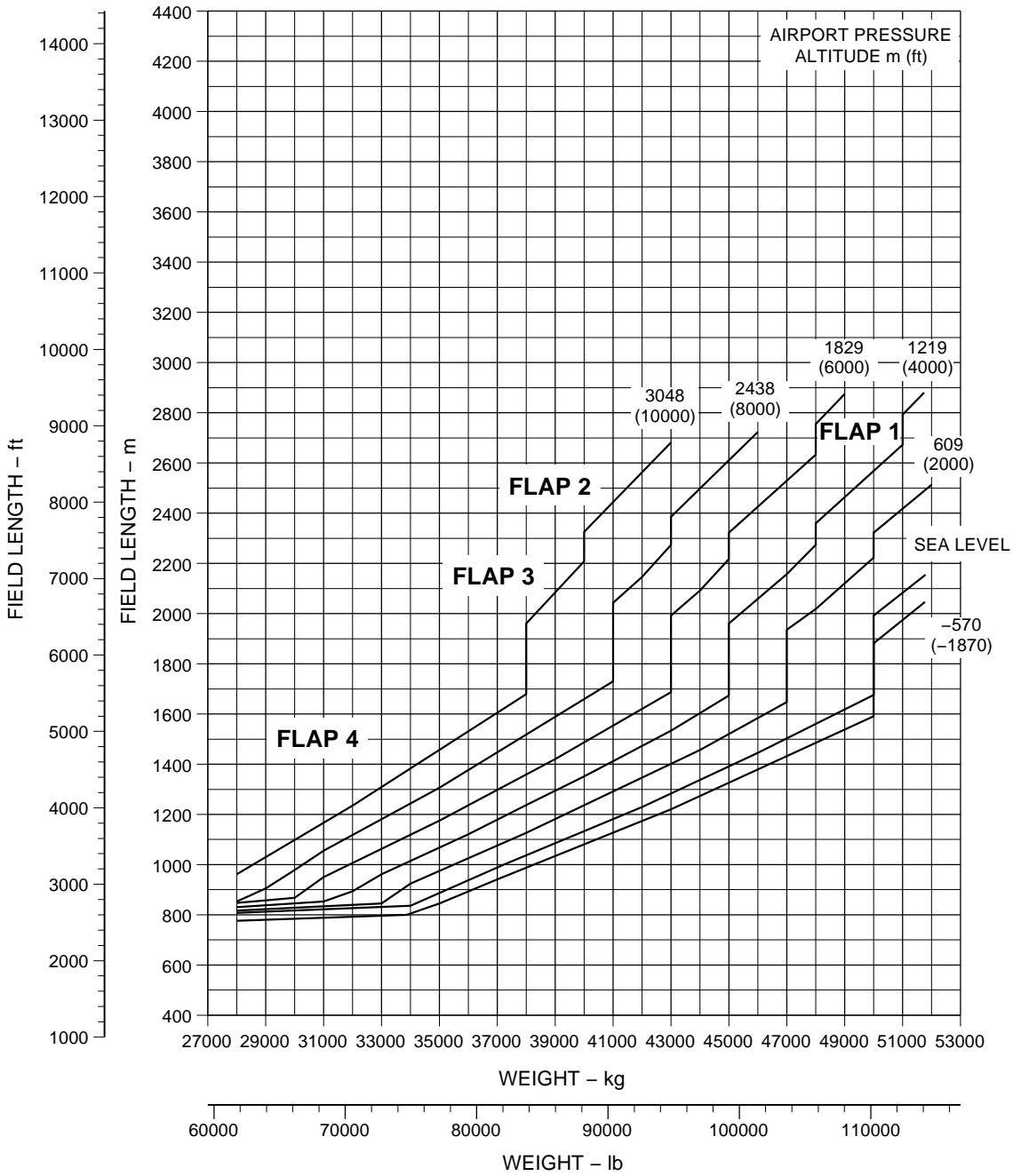
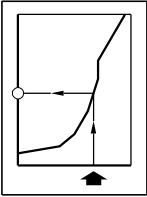

Takeoff Field Lengths - ISA Conditions  
 Figure 3.15

EM170APM030105A.DGN

EFFECTIVITY: ALL



# EMBRAER 190 AIRPORT PLANNING MANUAL

**TAKEOFF FIELD LENGTH**  
 CF 34-10E7 ENGINE@T/O-1 MODE  
 ATTCS OFF / ECS OFF  
 DRY, SMOOTH, HARD PAVED AND LEVEL RUNWAY  
 ISA+15

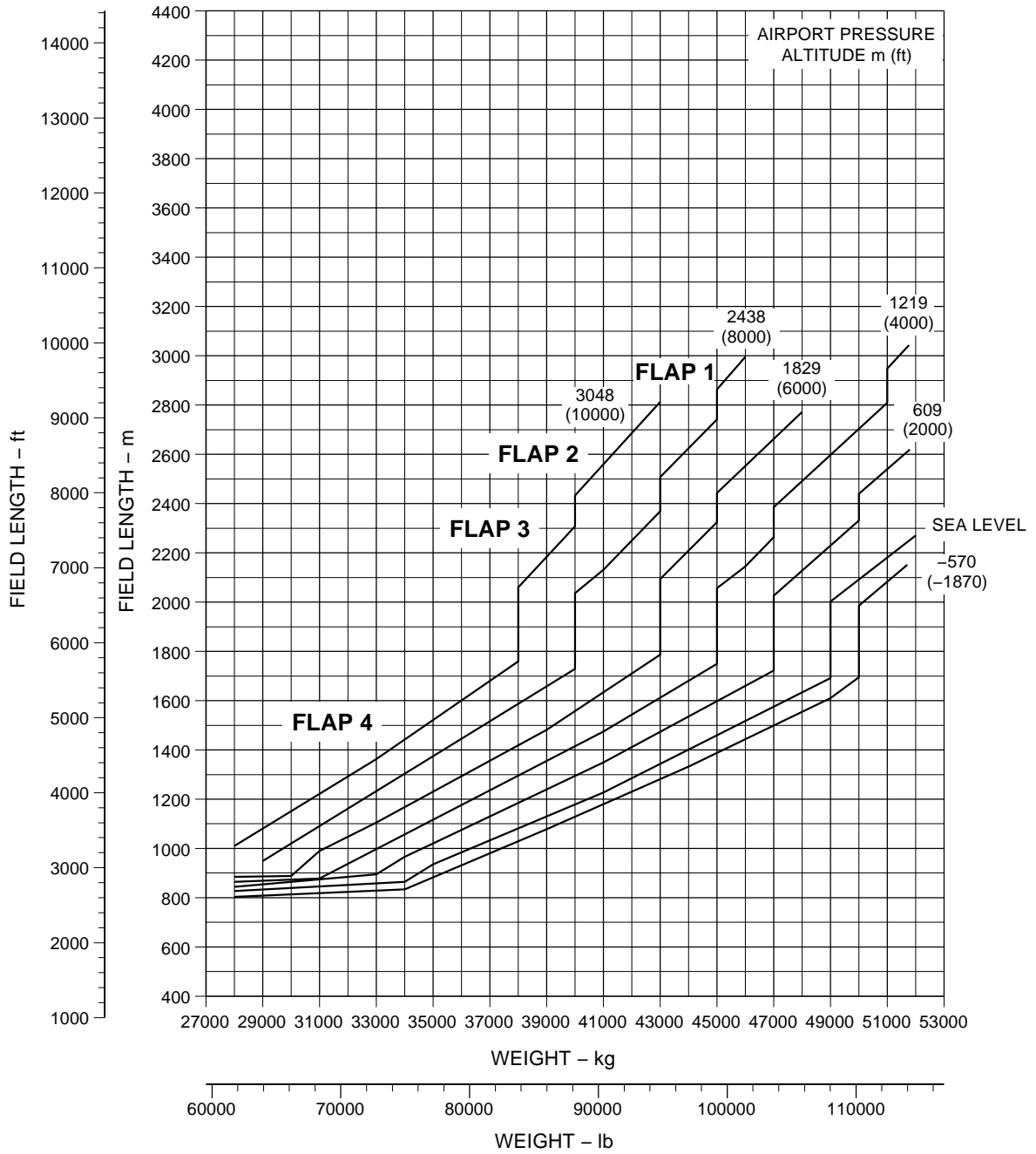
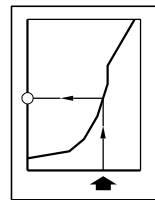

Takeoff Field Lengths - ISA + 15 °C Conditions  
 Figure 3.16

EM170APM030106A.DGN

EFFECTIVITY: ALL



### **3.4. LANDING FIELDS LENGTHS**

The landing field lengths charts provide data about the maximum landing weights for compliance with the operating regulations relating to landing field lengths.

Data is presented according to the following associated conditions:

- Landing gear: down;
- Flaps setting position: 5 or full;
- Pavement conditions: dry, hard paved and level runway surface with no obstacles;
- Zero wind and atmosphere according to ISA conditions;
- Pack OFF: No engine bleed extraction for air conditioning packs was considered in the takeoff and landing charts.





# EMBRAER 190 AIRPORT PLANNING MANUAL

**LANDING FIELD LENGTH**  
 CF 34-10E5-10E5A1-10E6 & -10E6A1 ENGINES  
 DRY, SMOOTH, HARD PAVED AND LEVEL RUNWAY  
 FLAP 5  
 ISA

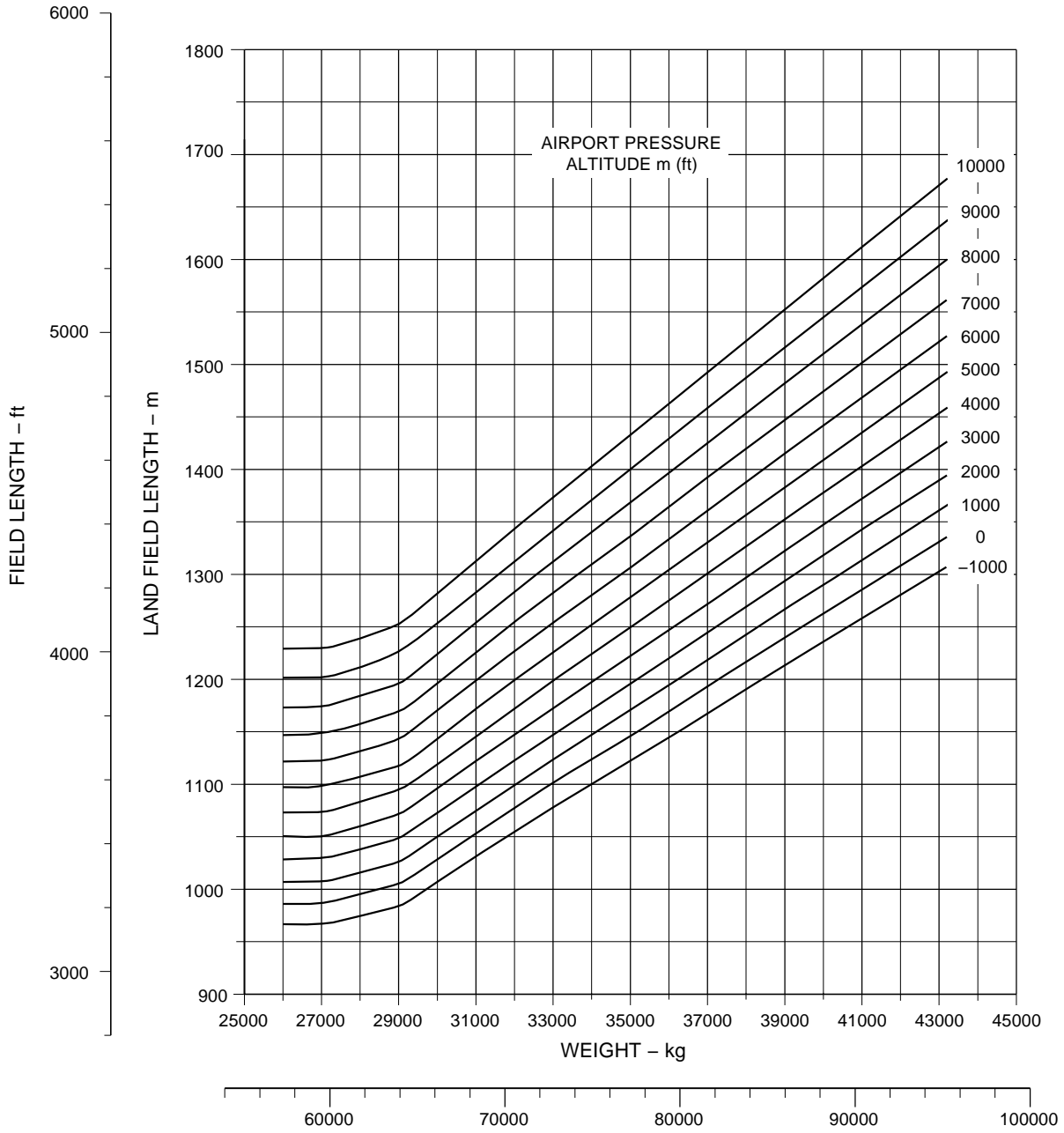
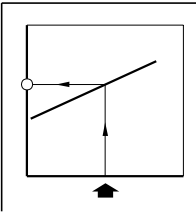

EM170APM030046C.DGN

Landing Field Lengths - Flaps 5  
Figure 3.17

EFFECTIVITY: EASA-CERTIFIED ACFT



# EMBRAER 190 AIRPORT PLANNING MANUAL

**LANDING FIELD LENGTH**  
 CF34-10E5-10E5A1-10E6 & -10E6A1 ENGINES  
 DRY, SMOOTH, HARD PAVED AND LEVEL RUNWAY  
 FLAP FULL  
 ISA

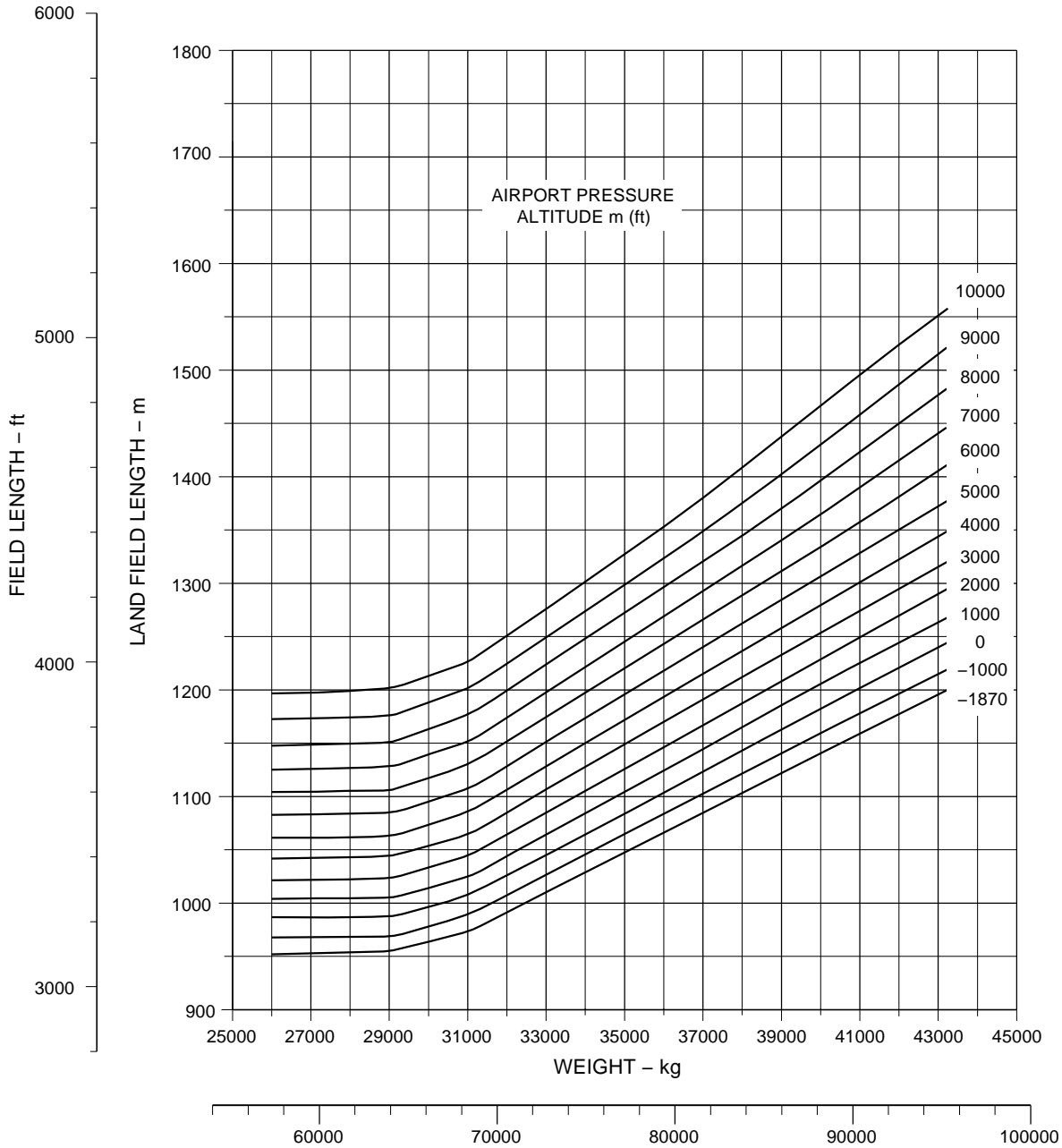
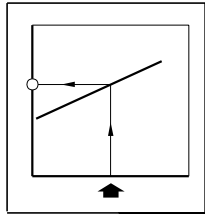

EM170APM030047C.DGN

Landing Field Lengths - Flaps Full  
 Figure 3.18

EFFECTIVITY: EASA-CERTIFIED ACFT



# EMBRAER 190 AIRPORT PLANNING MANUAL

**LANDING FIELD LENGTH**  
 CF 34-10E7 ENGINE  
 DRY, SMOOTH, HARD PAVED AND LEVEL RUNWAY  
 FLAP 5  
 ISA

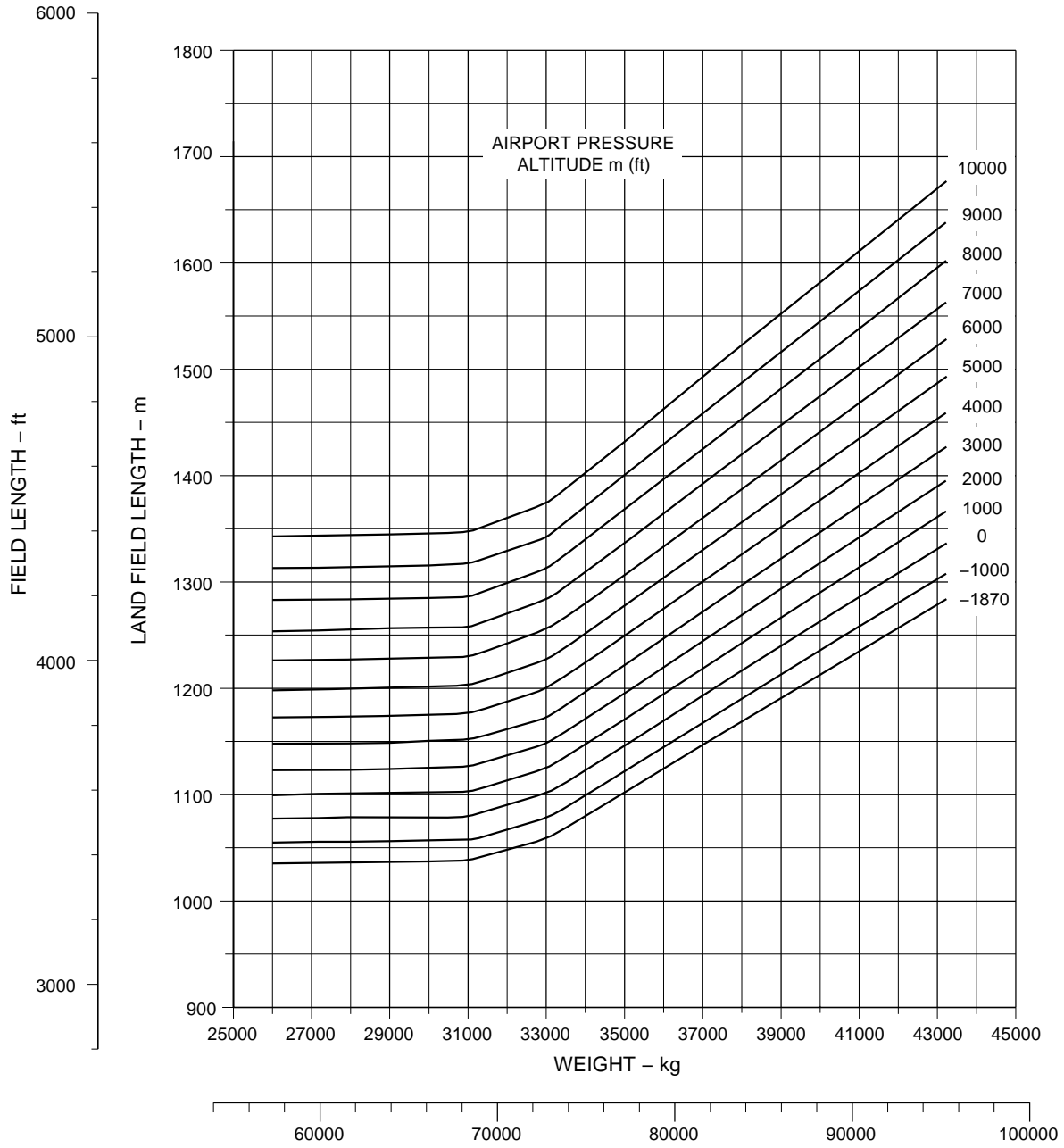
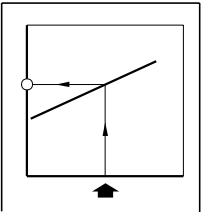

Landing Field Lengths - Flaps 5  
 Figure 3.19

EFFECTIVITY: EASA-CERTIFIED ACFT

EM170APM030062B.DGN

w-apm1901



# EMBRAER 190 AIRPORT PLANNING MANUAL

**LANDING FIELD LENGTH**  
 CF 34-10E7 ENGINE  
 DRY, SMOOTH, HARD PAVED AND LEVEL RUNWAY  
 FLAP FULL  
 ISA

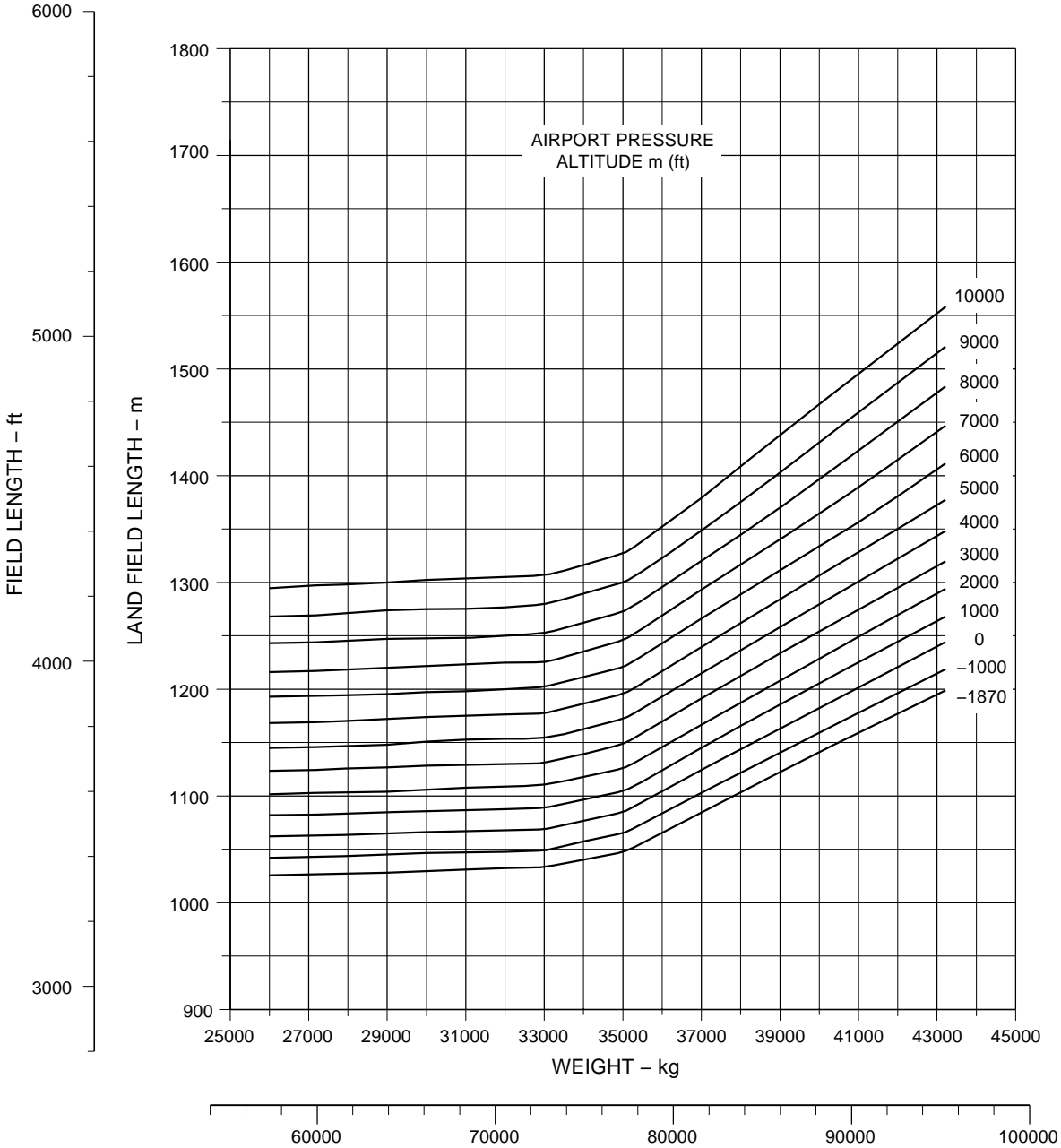
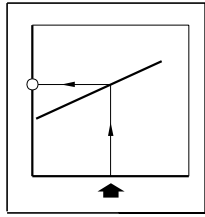

EM170APM030063B.DGN

Landing Field Lengths - Flaps Full  
 Figure 3.20

EFFECTIVITY: EASA-CERTIFIED ACFT



# EMBRAER 190 AIRPORT PLANNING MANUAL

**LANDING FIELD LENGTH**  
 CF 34-10E5-10E5A1-10E6 & -10E6A1 ENGINES  
 DRY, SMOOTH, HARD PAVED AND LEVEL RUNWAY  
 FLAP 5  
 ISA

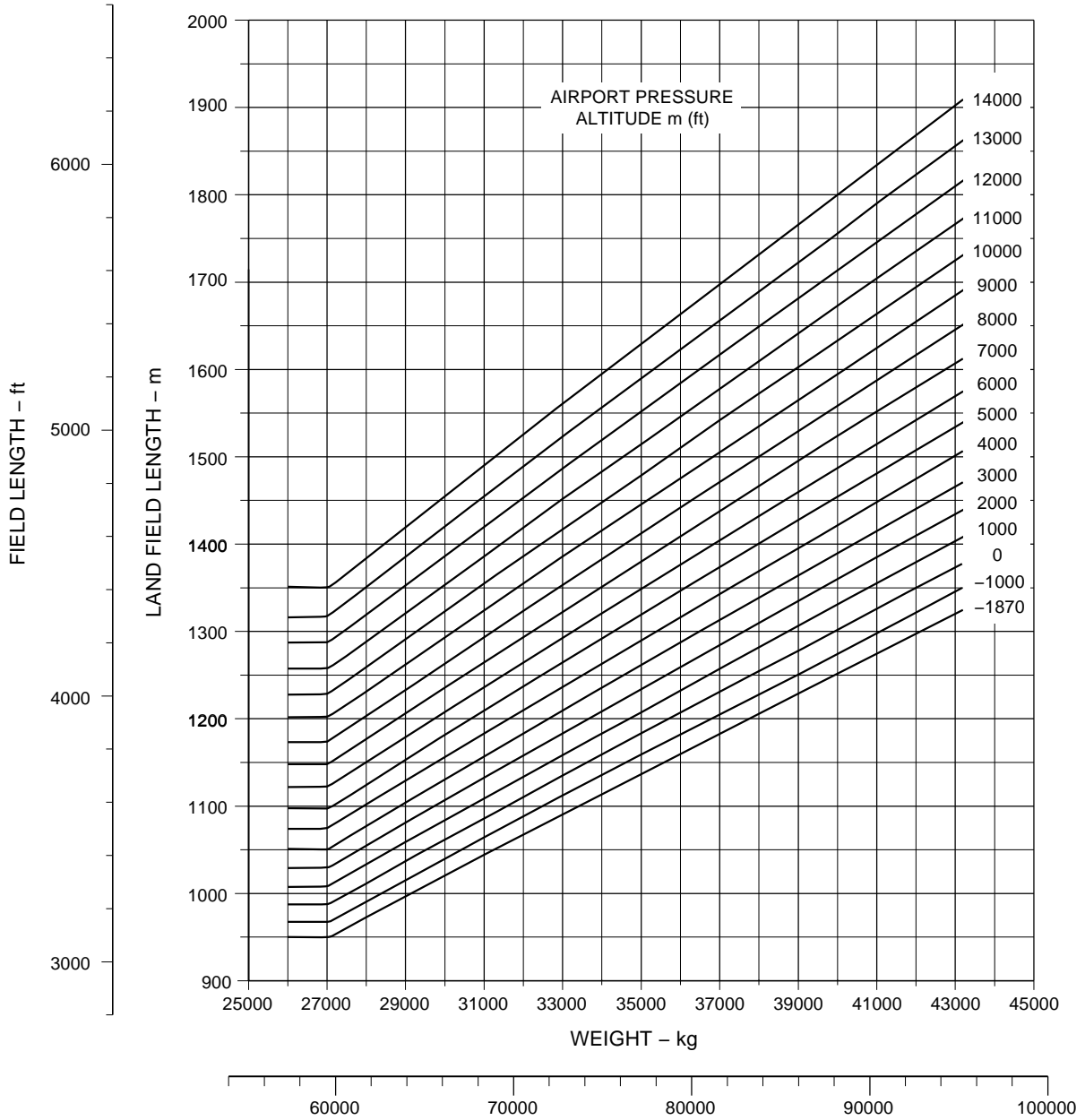
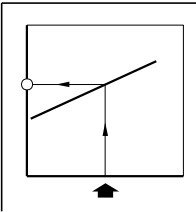

EM170APM030017A.DGN

Landing Field Lengths - Flaps 5  
 Figure 3.21

EFFECTIVITY: FAA-CERTIFIED ACFT



# EMBRAER 190 AIRPORT PLANNING MANUAL

**LANDING FIELD LENGTH**  
 CF 34-10E5-10E5A1-10E6 & -10E6A1 ENGINES  
 DRY, SMOOTH, HARD PAVED AND LEVEL RUNWAY  
 FLAP FULL  
 ISA

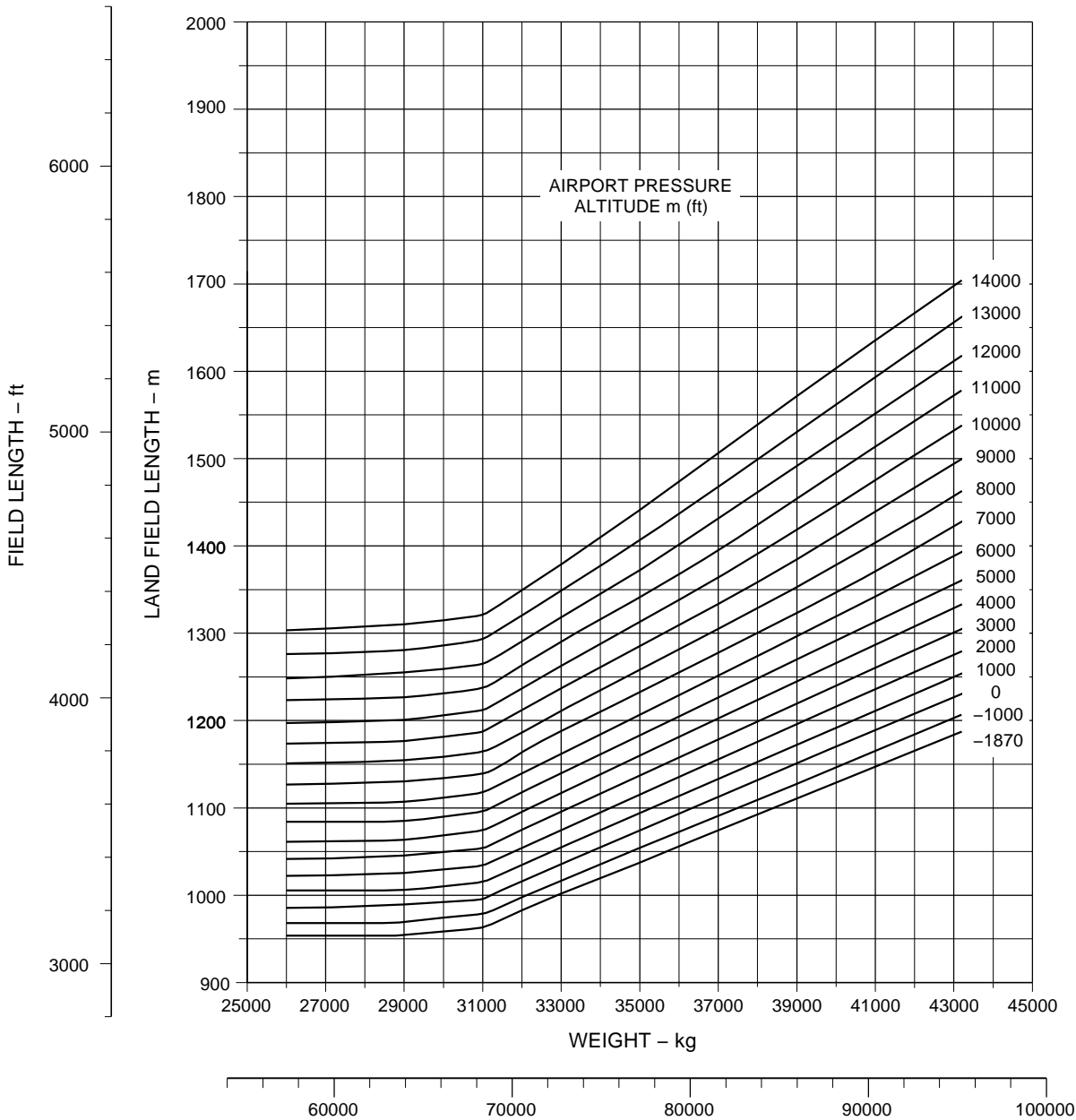
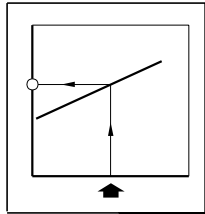

EM170APM030018A.DGN

Landing Field Lengths - Flaps Full  
 Figure 3.22

EFFECTIVITY: FAA-CERTIFIED ACFT



# EMBRAER 190 AIRPORT PLANNING MANUAL

**LANDING FIELD LENGTH**  
 CF 34-10E7 ENGINES  
 DRY, SMOOTH, HARD PAVED AND LEVEL RUNWAY  
 FLAP 5  
 ISA

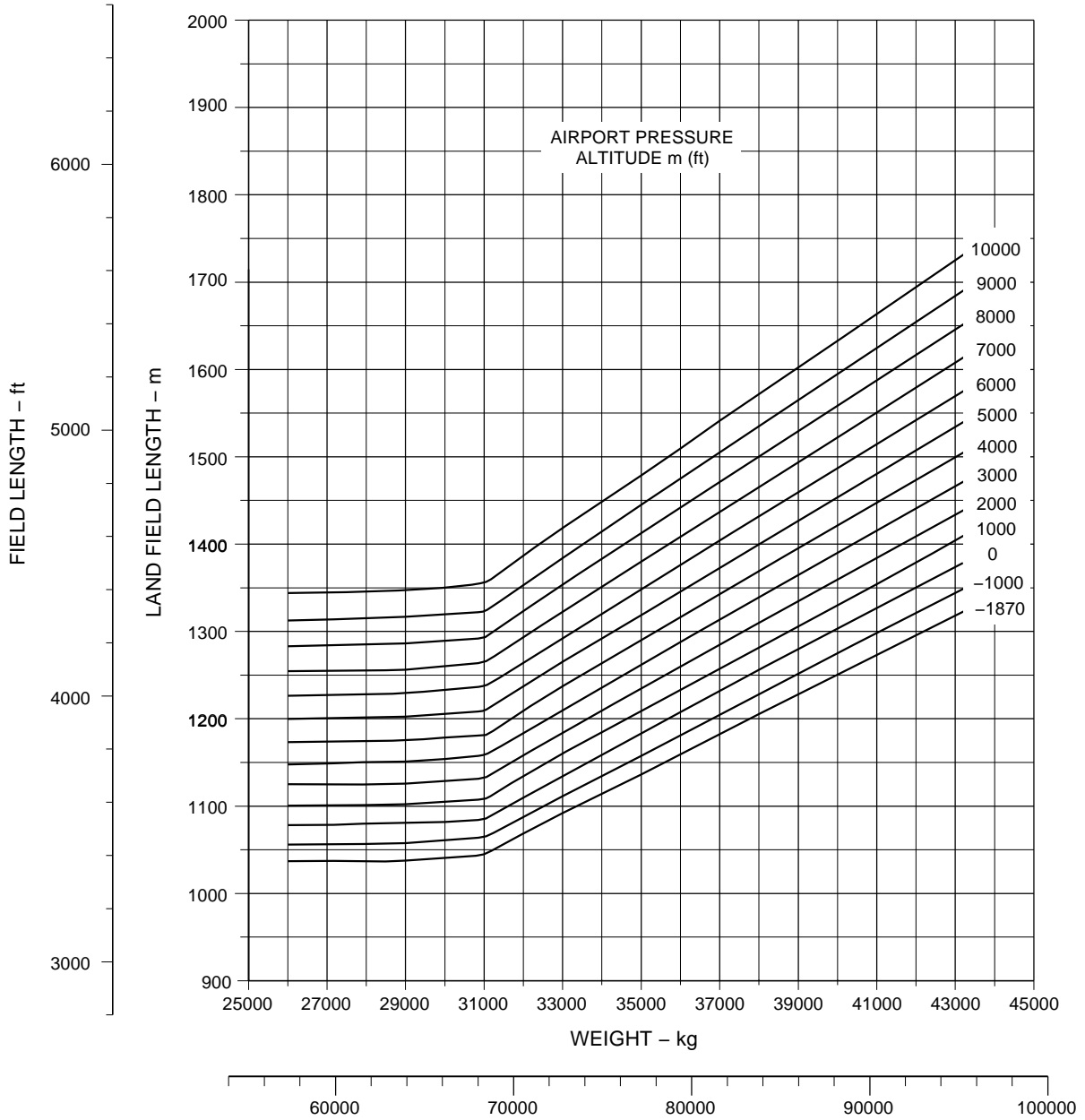
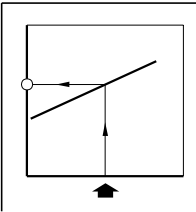

Landing Field Lengths - Flaps 5  
 Figure 3.23

EFFECTIVITY: FAA-CERTIFIED ACFT



# EMBRAER 190 AIRPORT PLANNING MANUAL

**LANDING FIELD LENGTH**  
 CF 34-10E7 ENGINES  
 DRY, SMOOTH, HARD PAVED AND LEVEL RUNWAY  
 FLAP FULL  
 ISA

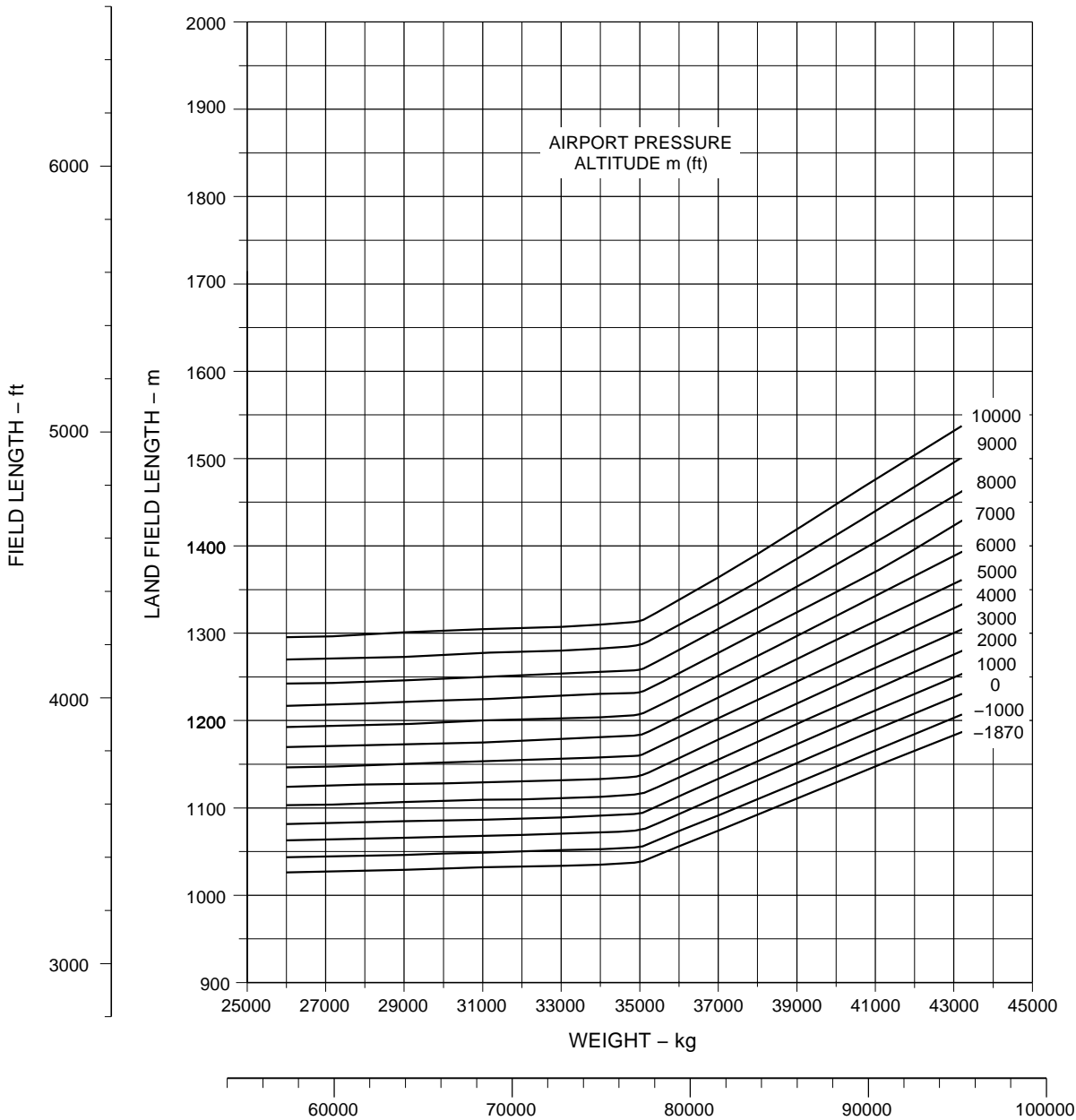
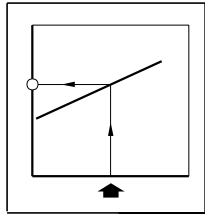

EM170APM030020A.DGN

Landing Field Lengths - Flaps Full  
 Figure 3.24

EFFECTIVITY: FAA-CERTIFIED ACFT





## **4. GROUND MANEUVERING**

### **4.1. GENERAL INFORMATION**

This section provides the aircraft turning capability and maneuvering characteristics. To facilitate the presentation, these data have been determined from theoretical limits imposed by the geometry of the aircraft.

As such, they reflect the turning capability of the aircraft in favorable operating circumstances. These data should be used only as guidelines for the method of determining such parameters and for the maneuvering characteristics of the aircraft.

In the ground operating mode, varying airline practices may demand that more conservative turning procedures be adopted, to avoid excessive tire wear and reduce possible maintenance problems.

Variations from standard aircraft operating patterns may be necessary to satisfy physical constants within the maneuvering area, such as adverse grades, limited area, or high risk of jet blast damage. For these reasons, the ground maneuvering requirements should be coordinated with the using airline prior to the layout planning.

This section is presented as follows:

- The turning radii for nose landing gear steering angles.
- The pilot's visibility from the cockpit and the limits of ambinocular vision through the windows. Ambinocular vision is defined as the total field of vision seen by both eyes at the same time.
- The performance of the aircraft on runway-to-taxiway, taxiway-to-taxiway and runway holding bays dimensions.

### **4.2. TURNING RADII**

This subsection presents the following information:

- The turning radii for various nose landing gear steering angles. The minimum turning radius is determined, considering that the maximum nose landing gear steering angle is 76 degrees left and right.
- Data on the minimum width of the pavement for a 180° turn.



# EMBRAER 190 AIRPORT PLANNING MANUAL

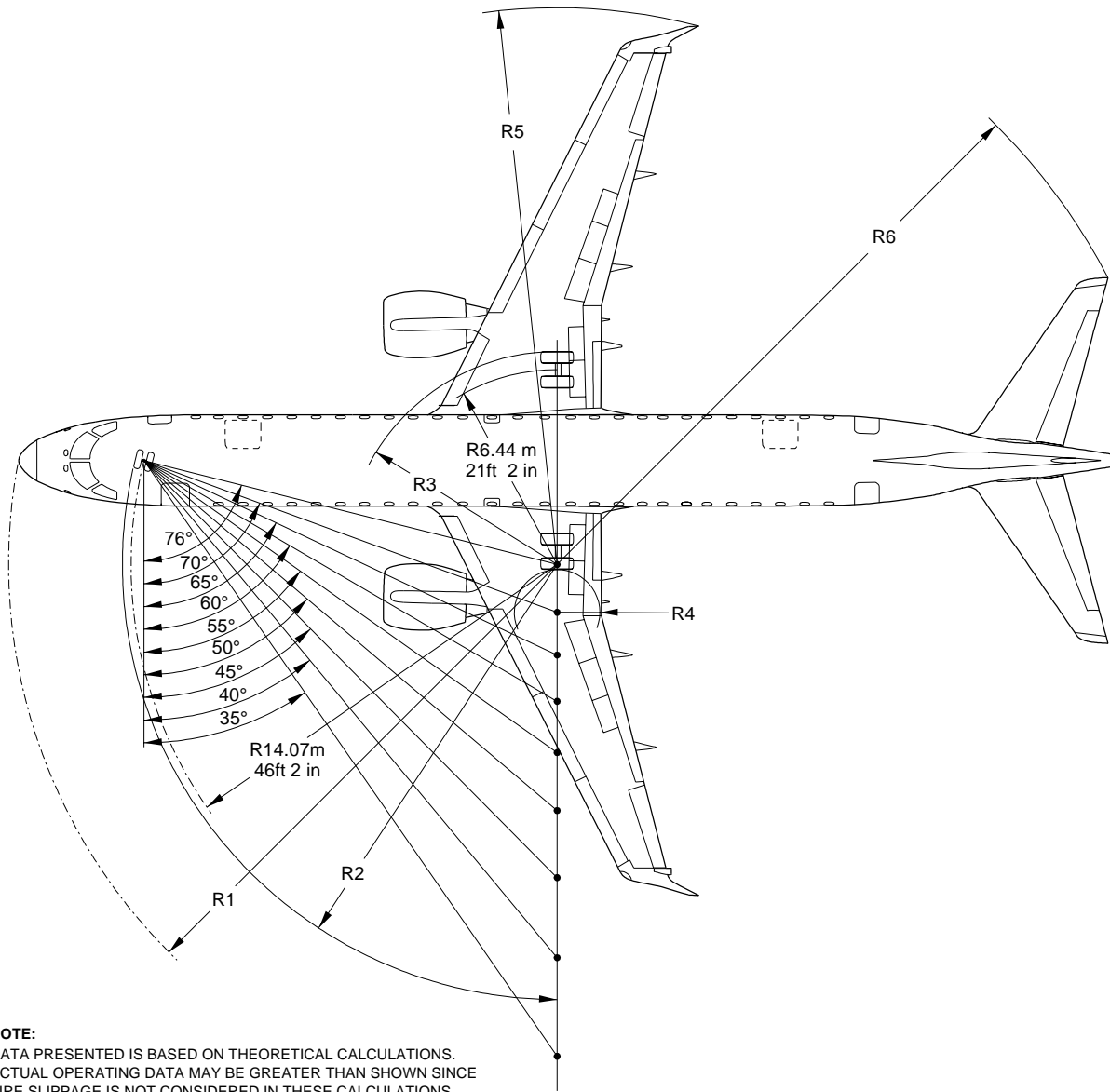

**NOTE:**  
 DATA PRESENTED IS BASED ON THEORETICAL CALCULATIONS.  
 ACTUAL OPERATING DATA MAY BE GREATER THAN SHOWN SINCE  
 TIRE SLIPPAGE IS NOT CONSIDERED IN THESE CALCULATIONS.

STEERING STEEL	NOSE		NOSE GEAR		OUTBOARD GEAR		INBOARD GEAR		RIGHT WINGLET		RIGHT TAILTIP	
	R1	R2	R3	R4	R5	R6						
35°	26.53 m / 87 ft	24.16 m / 79 ft 3 in	23.28 m / 76 ft 5 in	16.08 m / 52 ft 9 in	34.35 m / 112 ft 8 in	31.50 m / 103 ft 4 in						
40°	24.21 m / 79 ft 5 in	21.58 m / 70 ft 10 in	20.03 m / 65 ft 9 in	12.82 m / 42 ft 1 in	31.13 m / 102 ft 2 in	28.91 m / 94 ft 10 in						
45°	22.50 m / 73 ft 10 in	19.64 m / 64 ft 5 in	17.38 m / 57 ft	10.18 m / 35 ft 5 in	28.52 m / 93 ft 7 in	26.90 m / 88 ft 3 in						
50°	21.22 m / 69 ft 7 in	18.14 m / 59 ft 6 in	15.17 m / 49 ft 9 in	7.96 m / 26 ft 1 in	26.33 m / 86 ft 5 in	25.32 m / 83 ft 1 in						
55°	20.24 m / 66 ft 5 in	16.98 m / 55 ft 9 in	13.25 m / 43 ft 6 in	6.05 m / 19 ft 10 in	24.45 m / 80 ft 3 in	24.02 m / 78 ft 10 in						
60°	19.49 m / 63 ft 11 in	16.07 m / 52 ft 9 in	11.56 m / 37 ft 11 in	4.35 m / 14 ft 3 in	22.79 m / 74 ft 9 in	22.95 m / 75 ft 4 in						
65°	18.91 m / 63 ft	15.36 m / 50 ft 5 in	10.03 m / 32 ft 11 in	2.82 m / 9 ft 3 in	21.30 m / 69 ft 10 in	22.05 m / 72 ft 4 in						
70°	18.48 m / 60 ft 8 in	14.82 m / 48 ft 7 in	8.62 m / 28 ft 3 in	1.41 m / 4 ft 8 in	19.93 m / 65 ft 5 in	21.29 m / 69 ft 10 in						
76°	18.12 m / 59 ft 5 in	14.36 m / 47 ft 1 in	7.04 m / 23 ft 1 in	0.17 m / 7 in	18.39 m / 60 ft 4 in	20.51 m / 67 ft 3 in						

EM170APM040008B.DGN

Turning Radii - No Slip Angle  
 Figure 4.1

EFFECTIVITY: ALL



**4.3. MINIMUM TURNING RADII**

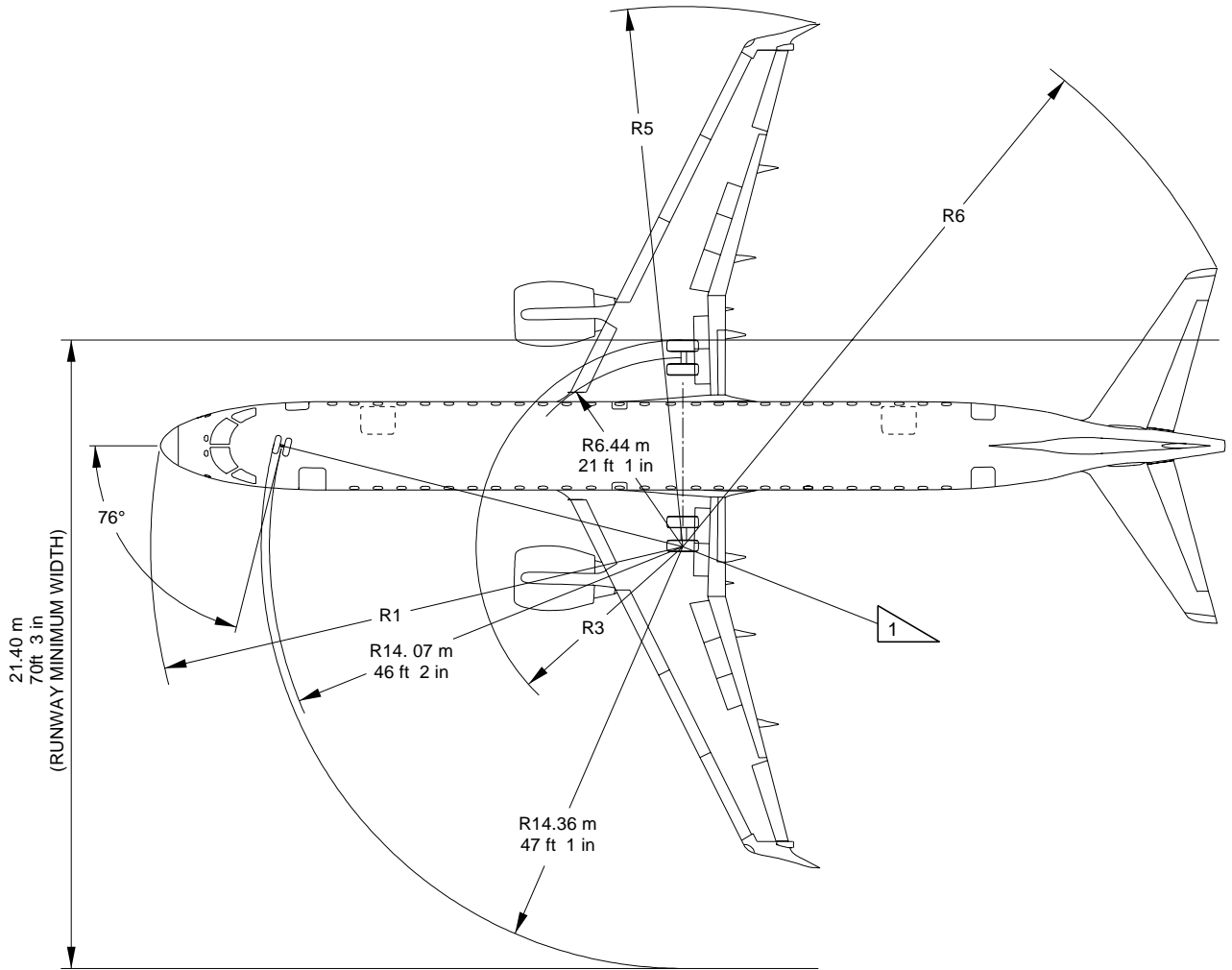

**NOTE:**  
ACTUAL OPERATING DATA MAY BE GREATER THAN VALUES SHOWN  
SINCE TIRE SLIPPAGE IS NOT CONSIDERED IN THESE CALCULATIONS.

STEERING STEEL	NOSE		NOSE GEAR		OUTBOARD GEAR		INBOARD GEAR		RIGHT WINGLET		RIGHT TAILTIP	
	R1	R2	R3	R4	R5	R6						
76°	18.12 m 59 ft 5 in	14.36 m 47 ft 1 in	7.04 m 23 ft 1 in	0.17 m 7 in	18.39 m 60 ft 4 in	20.51 m 67 ft 3 in						

**1** THEORETICAL CENTER OF TURN FOR MINIMUM RADIUS.  
SHOWS CONTINUOUS TURNING WITH ENGINE THRUST AS REQUIRED.  
NO DIFFERENTIAL BRAKING.

EM170APM040009B.DGN

Minimum Turning Radius  
Figure 4.2

EFFECTIVITY: ALL



# EMBRAER 190 AIRPORT PLANNING MANUAL

## 4.4. VISIBILITY FROM COCKPIT

VISUAL ANGLE IN PLANE PARALLEL TO LONGITUDINAL AXIS THROUGH PILOT'S EYE POSITION

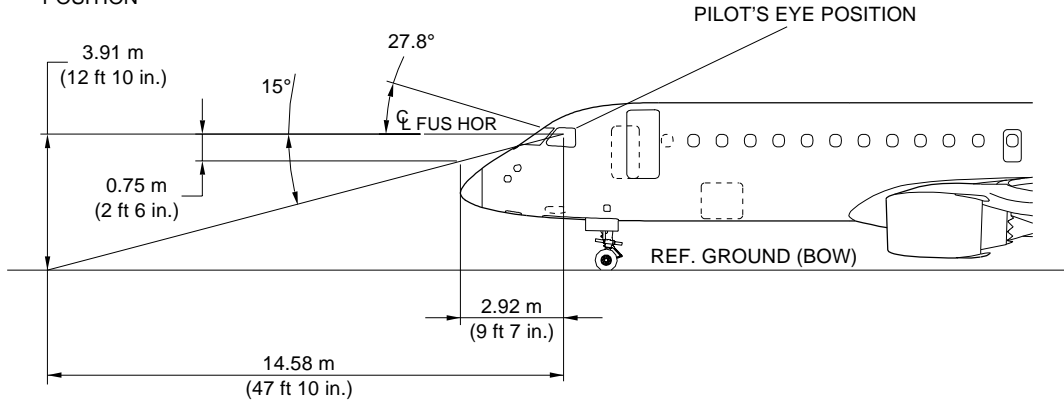

MAXIMUM AFT VISION WITH HEAD ROTATED ABOUT SPINAL COLUMN

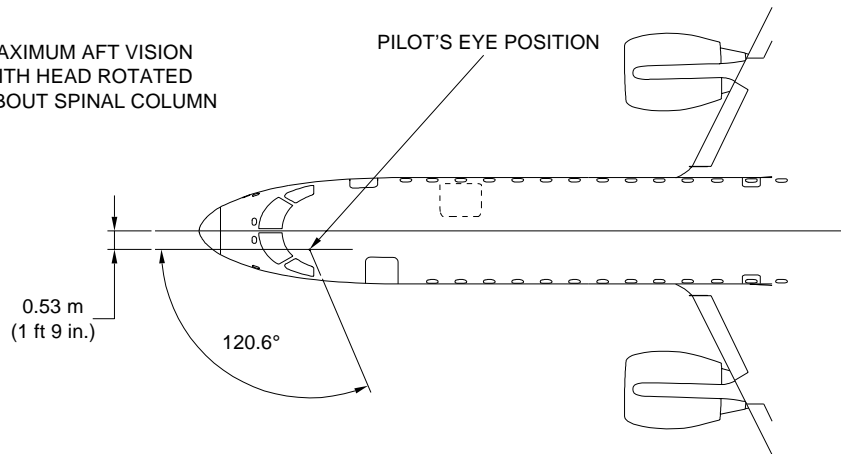

VISUAL ANGLE IN PLANE PERPENDICULAR TO LONGITUDINAL AXIS THROUGH PILOT'S EYE POSITION

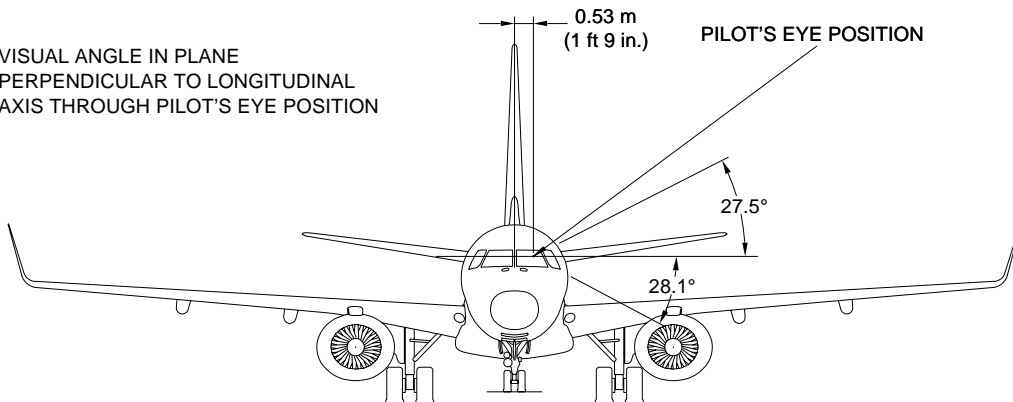

EM170APM040010.DGN

Visibility from Cockpit in Static Position  
Figure 4.3

EFFECTIVITY: ALL



**4.5. RUNWAY AND TAXIWAY DIMENSIONS**

To determine the minimum dimensions for runway and taxiway where the aircraft can be operated, the reference code of the aircraft must be determined.

The reference code of a specific aircraft is obtained in accordance with the Aerodrome Design and Operations - Volume 1, by the ICAO.

The code is composed of two elements which are related to the aircraft performance characteristics and dimensions:

- Element 1 is a number based on the aircraft reference field length;
- Element 2 is a letter based on the aircraft wingspan and outer main landing gear wheel span.

The table below shows the reference codes:

Table 4.1 - Reference Codes

CODE ELEMENT 1		CODE ELEMENT 2		
CODE NUMBER	AIRCRAFT REFERENCE FIELD LENGTH	CODE LETTER	WING SPAN	OUTER MAIN LANDING GEAR WHEEL SPAN
1	less than 800 m (2624 ft 8 in)	A	Up to 15 m (49 ft 3 in)	Up to 4.5 m (14 ft 9 in)
2	800 m (2624 ft 8 in) up to 1200 m (3937 ft)	B	15 m (49 ft 3 in) to 24 m (78 ft 9 in)	4.5 m (14 ft 9 in) to 6 m (19 ft 8 in)
3	1200 m (3937 ft) up to 1800 m (5905 ft 6 in)	C	24 m (78 ft 9 in) to 36 m (118 ft 1 in)	6 m (19 ft 8 in) to 9 m (29 ft 6 in)
4	1800 m (5905 ft 6 in) and over	D	36 m (118 ft 1 in) to 52 m (170 ft 7 in)	9 m (29 ft 6 in) to 14 m (45 ft 11 in)
5	–	E	52 m (170 ft 7 in) to 65 m (213 ft 3 in)	9 m (29 ft 6 in) to 14 m (45 ft 11 in)

In accordance with the table, the reference code is 3C for EMBRAER 190STD, EMBRAER 190LR and EMBRAER 190AR.

**NOTE:**

- This classification may change depending on aircraft engine model and takeoff weight.
- For further information, refer to AOM.

With the reference code it is possible to obtain the limits of the runway and taxiway where the aircraft can be operated.

For reference code 3C the limits are:

- The width of a runway should be not less than 30 m (98 ft 5 in);
- The width of a taxiway should be not less than 15 m (49 ft 2 in);
- The design of the curve in a taxiway should be such that, when the cockpit remains over the taxiway centre line marking, the clearance distance between the outer main landing gear wheels of the aircraft and the edge of the taxiway should not be less than 3 m (9 ft 10 in);
- The clearance between a parked aircraft and one moving along the taxiway in a holding bay should

EFFECTIVITY: ALL



# **EMBRAER 190** AIRPORT PLANNING MANUAL

not be less than 15 m (49 ft 2 in).

For reference code 4C the limits are:

- The width of a runway should be not less than 30 m (147 ft 7.6 in);
- The width of a taxiway should be not less than 15 m (49 ft 2 in);
- The design of the curve in a taxiway should be such that, when the cockpit remains over the taxiway centre line marking, the clearance distance between the outer main landing gear wheels of the aircraft and the edge of the taxiway should not be less than 3 m (9 ft 10 in);
- The clearance between a parked aircraft and one moving along the taxiway in a holding bay should not be less than 15 m (49 ft 2 in).

EFFECTIVITY: ALL

**Section 4**

Page 4-6

May 25/18



# EMBRAER 190 AIRPORT PLANNING MANUAL

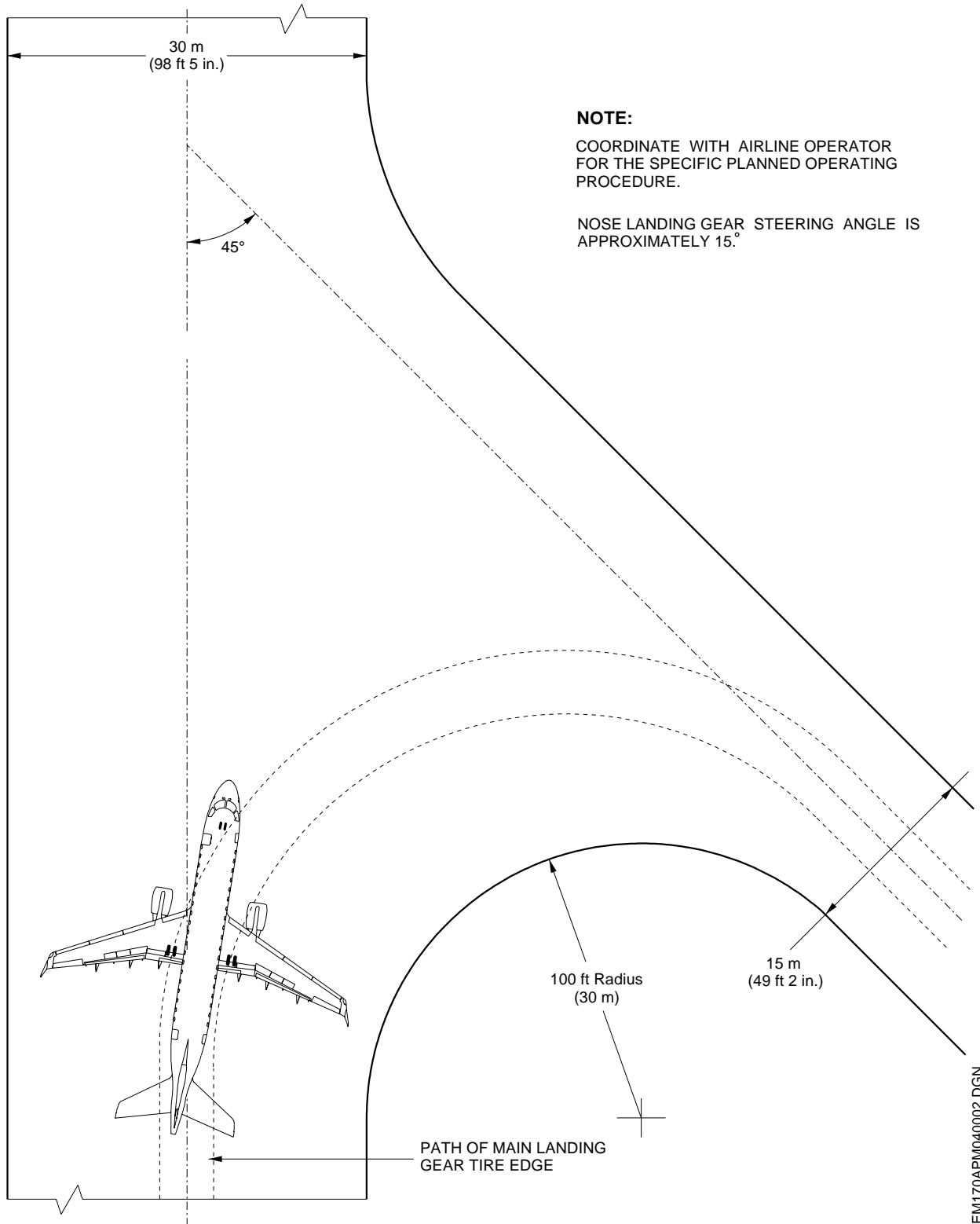

More than 90° Turn - Runway to Taxiway  
Figure 4.4

EFFECTIVITY: EMBRAER 190 STD ACFT MODEL



# EMBRAER 190 AIRPORT PLANNING MANUAL

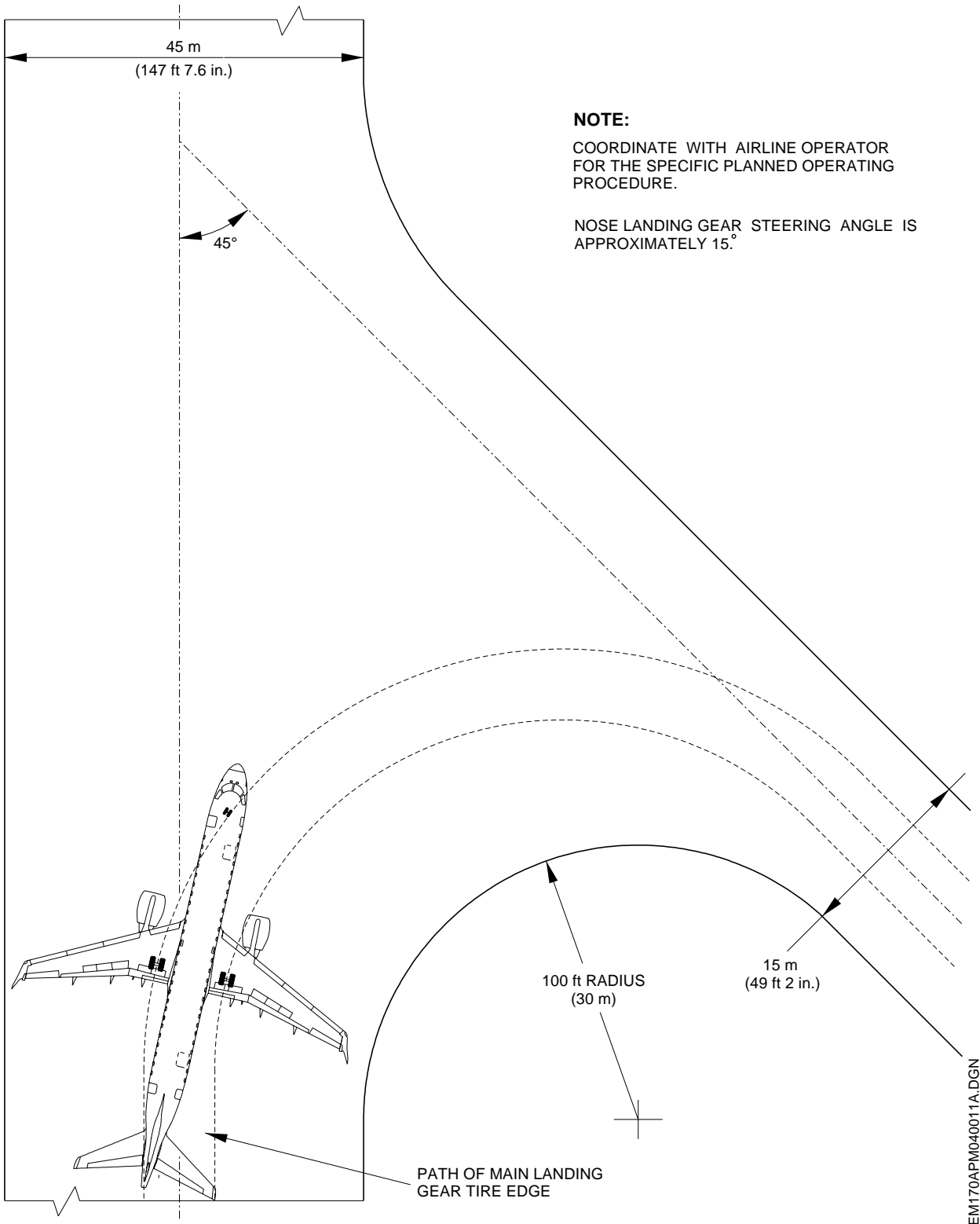

More than 90° Turn - Runway to Taxiway  
Figure 4.5

EFFECTIVITY: EMBRAER ACFT 190 LR OR AR MODEL





# EMBRAER 190 AIRPORT PLANNING MANUAL

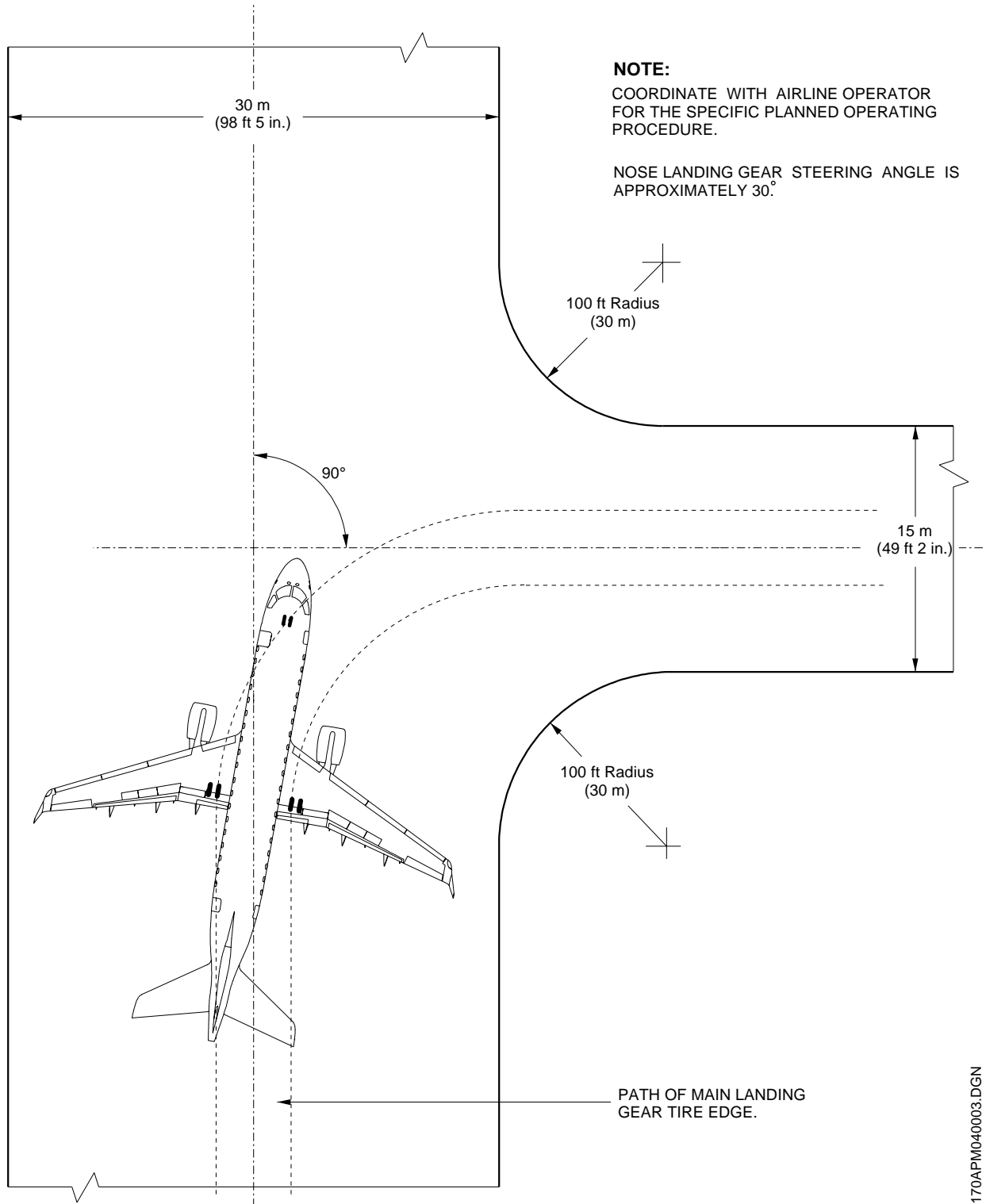

EM170APM040003.DGN

90° Turn - Runway to Taxiway  
Figure 4.6

EFFECTIVITY: EMBRAER 190 STD ACFT MODEL



# EMBRAER 190 AIRPORT PLANNING MANUAL

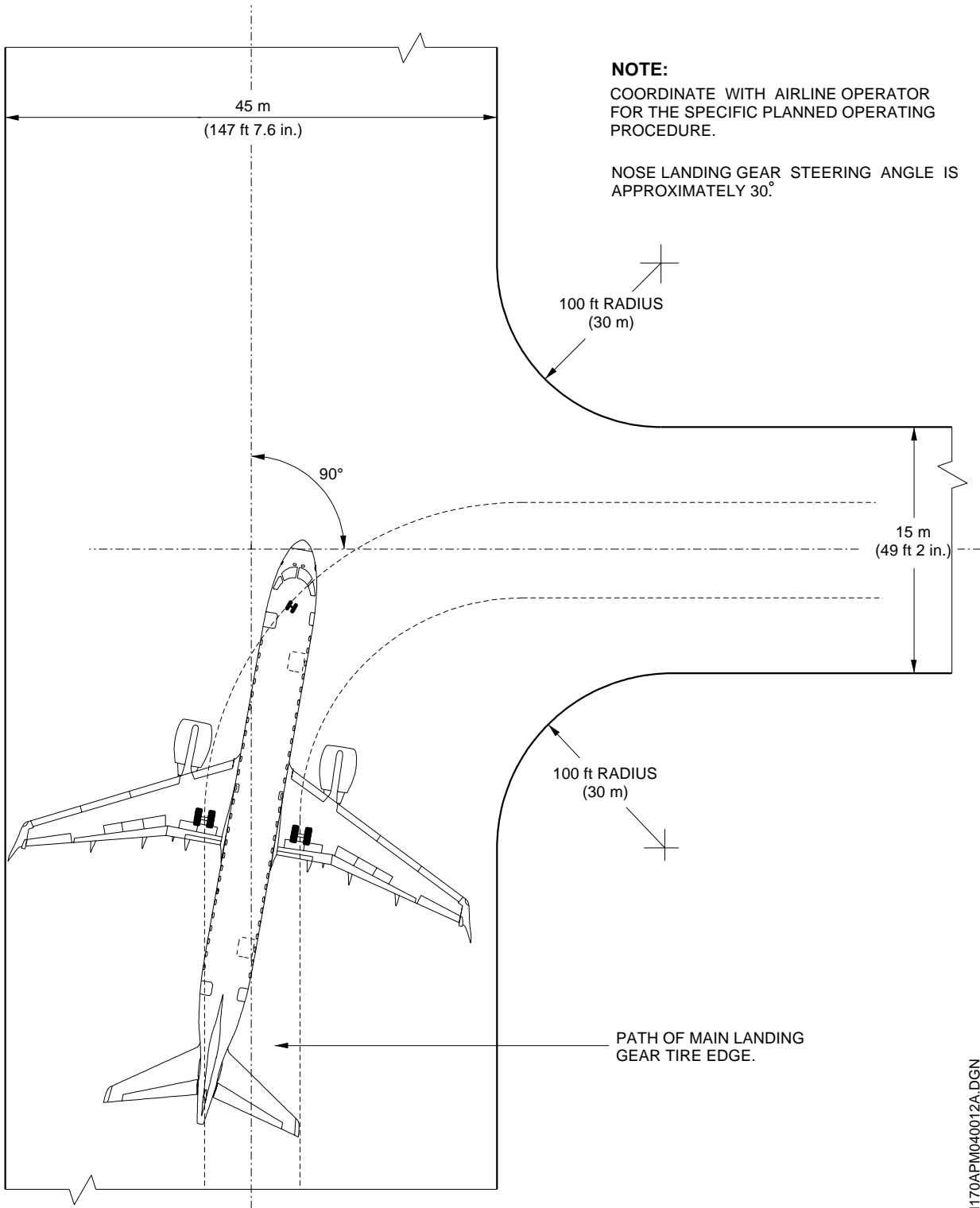

EM170APM040012A.DGN

90° Turn - Runway to Taxiway  
Figure 4.7

EFFECTIVITY: EMBRAER ACFT 190 LR OR AR MODEL



# EMBRAER 190 AIRPORT PLANNING MANUAL

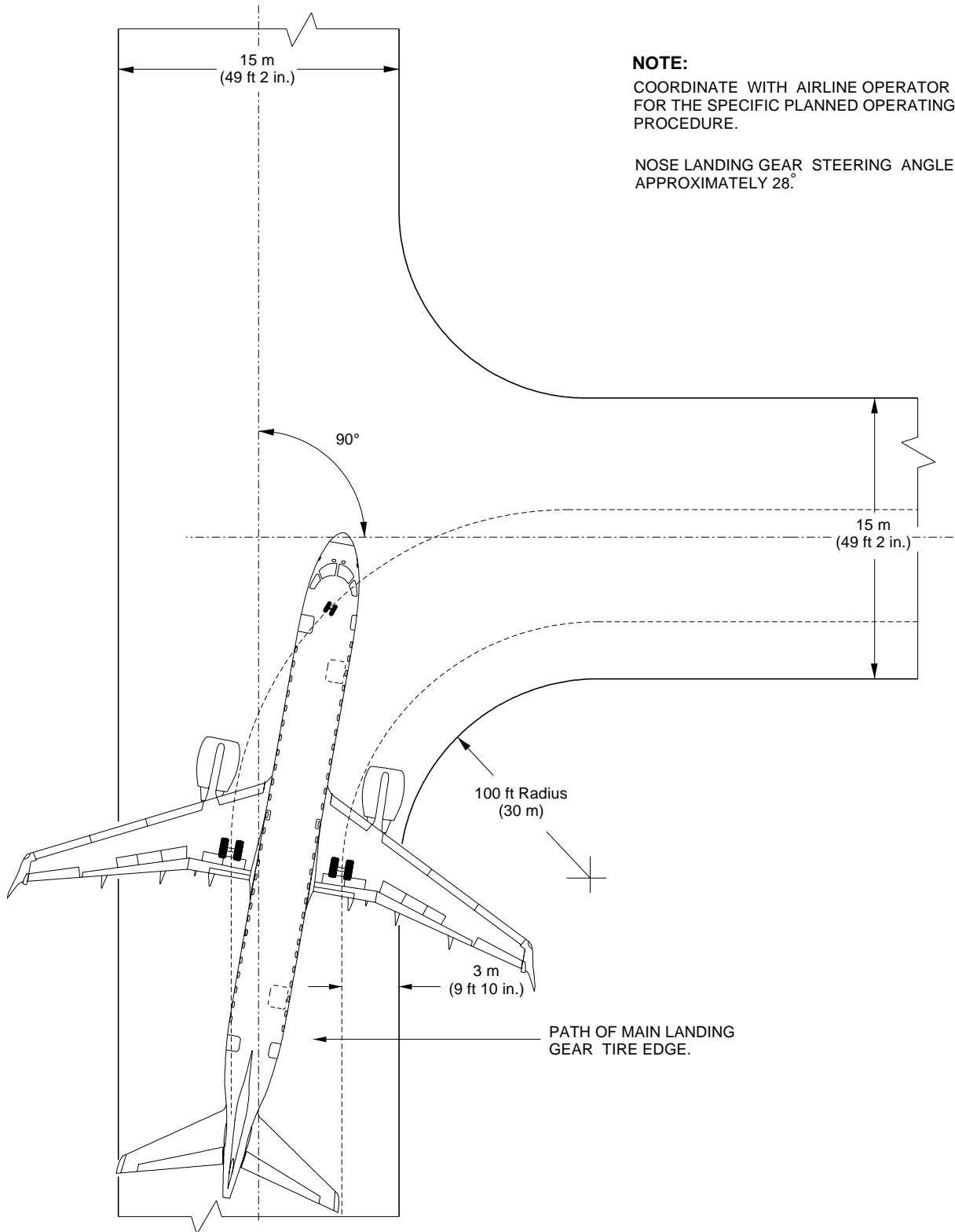

90° Turn - Taxiway to Taxiway  
Figure 4.8

EFFECTIVITY: ALL



## 4.6. RUNWAY HOLDING APRON

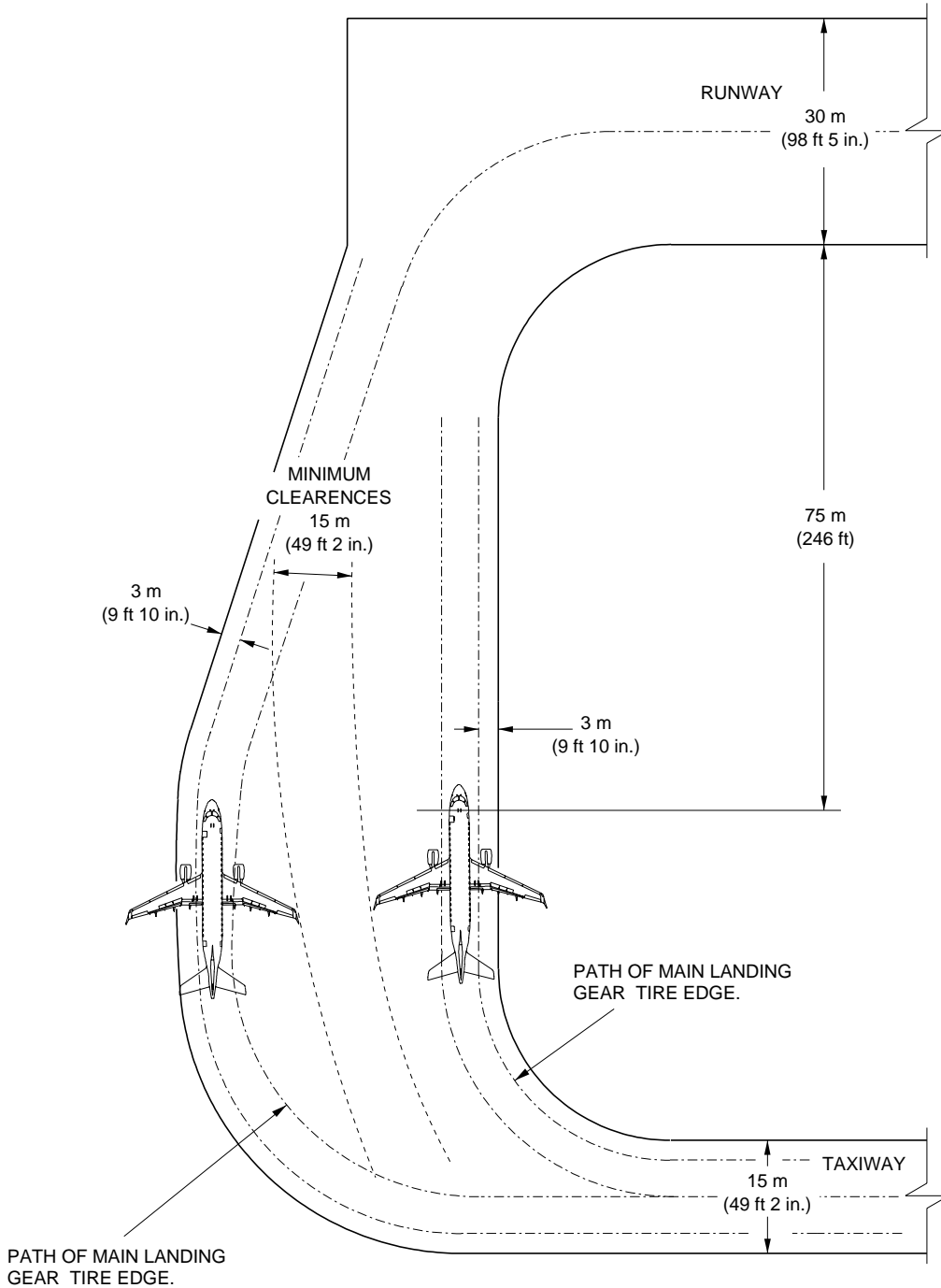

EM170APM040005.DGN

Runway Holding Bay  
Figure 4.9

EFFECTIVITY: EMBRAER 190 STD ACFT MODEL



# EMBRAER 190 AIRPORT PLANNING MANUAL

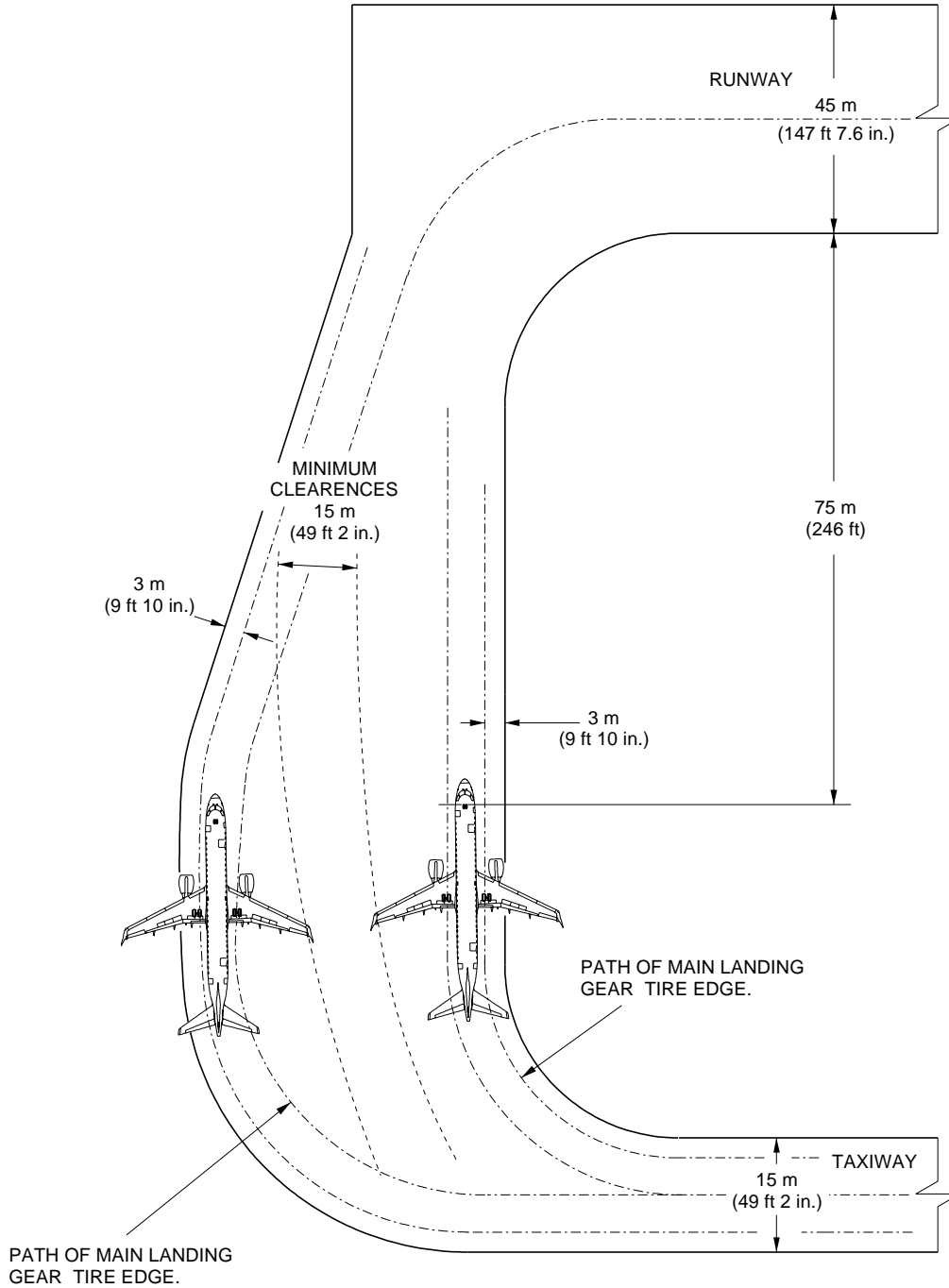

Runway Holding Bay  
Figure 4.10

EFFECTIVITY: EMBRAER ACFT 190 LR OR AR  
MODEL





## 5. TERMINAL SERVICING

During turnaround at the air terminal, certain services must be performed on aircraft, usually within a given time to meet flight schedules. This section shows service vehicle arrangements, schedules, locations of servicing points, and typical servicing requirements. The data presented herein reflect ideal conditions for a single aircraft. Servicing requirements may vary according to the aircraft condition and airline operational (servicing) procedures.

This section provides the following information:

- The typical arrangements of equipments during turnaround;
- The typical turnaround servicing time at an air terminal;
- The locations of ground servicing connections in graphic and tabular forms;
- The typical sea level air pressure and flow requirements for starting the engine;
- The air conditioning requirements;
- The ground towing requirements for various towing conditions. Towbar pull and total traction wheel load may be determined by considering aircraft weight, pavement slope, coefficient of friction, and engine idle thrust.



# EMBRAER 190 AIRPORT PLANNING MANUAL

## 5.1. AIRCRAFT SERVICING ARRANGEMENT

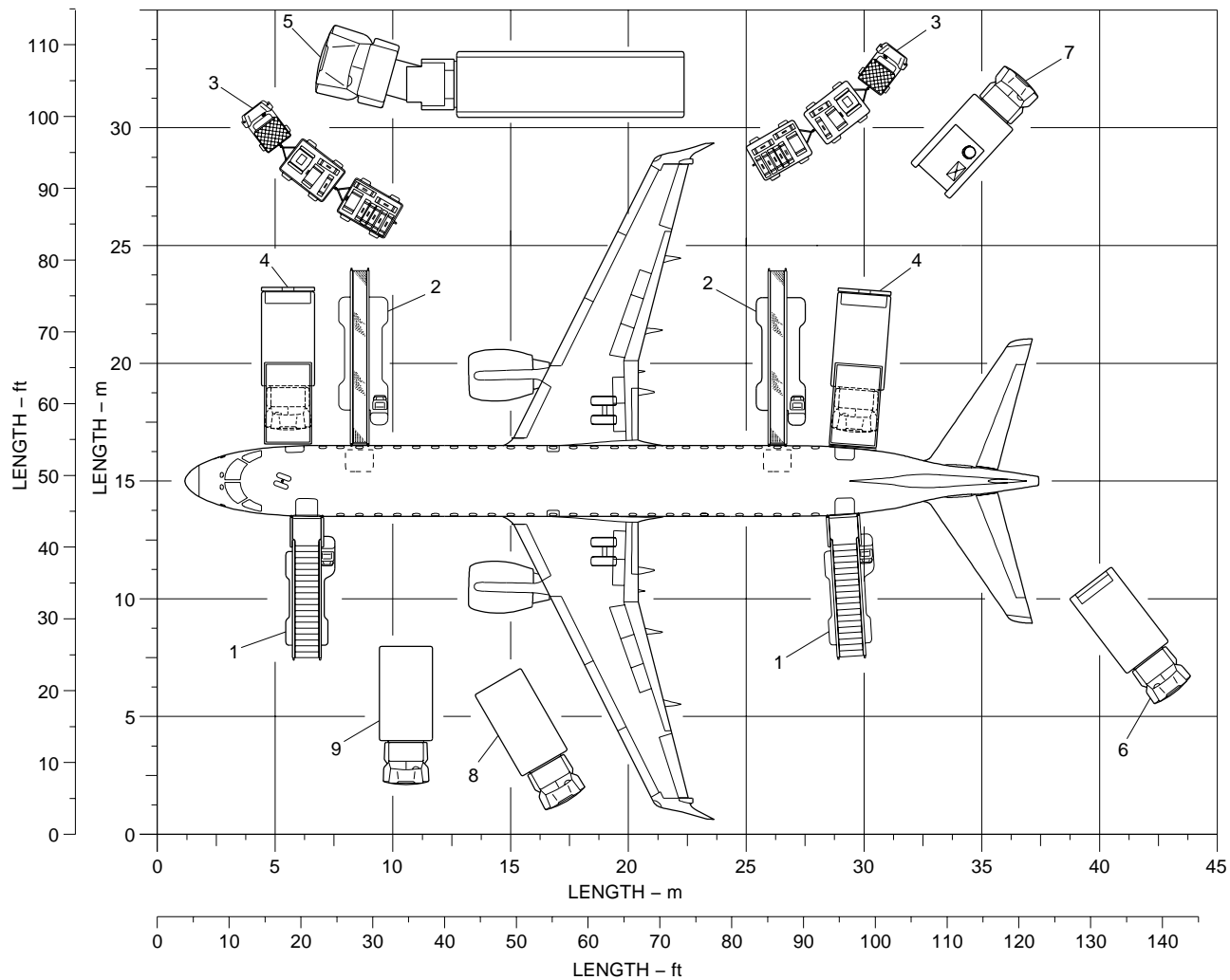

### SERVICING ARRANGEMENT

- 01 - PASSENGER STAIRS
- 02 - BAGGAGE LOADER
- 03 - BAGGAGE / CARGO
- 04 - GALLEY SERVICE
- 05 - FUEL SERVICE
- 06 - POTABLE WATER
- 07 - LAVATORY SERVICE
- 08 - AIR CONDITIONING
- 09 - PNEUMATIC STARTER

EM170APM050011A.DGN

Aircraft Servicing Arrangement With Passenger Stairs  
Figure 5.1

EFFECTIVITY: ALL





# EMBRAER 190 AIRPORT PLANNING MANUAL

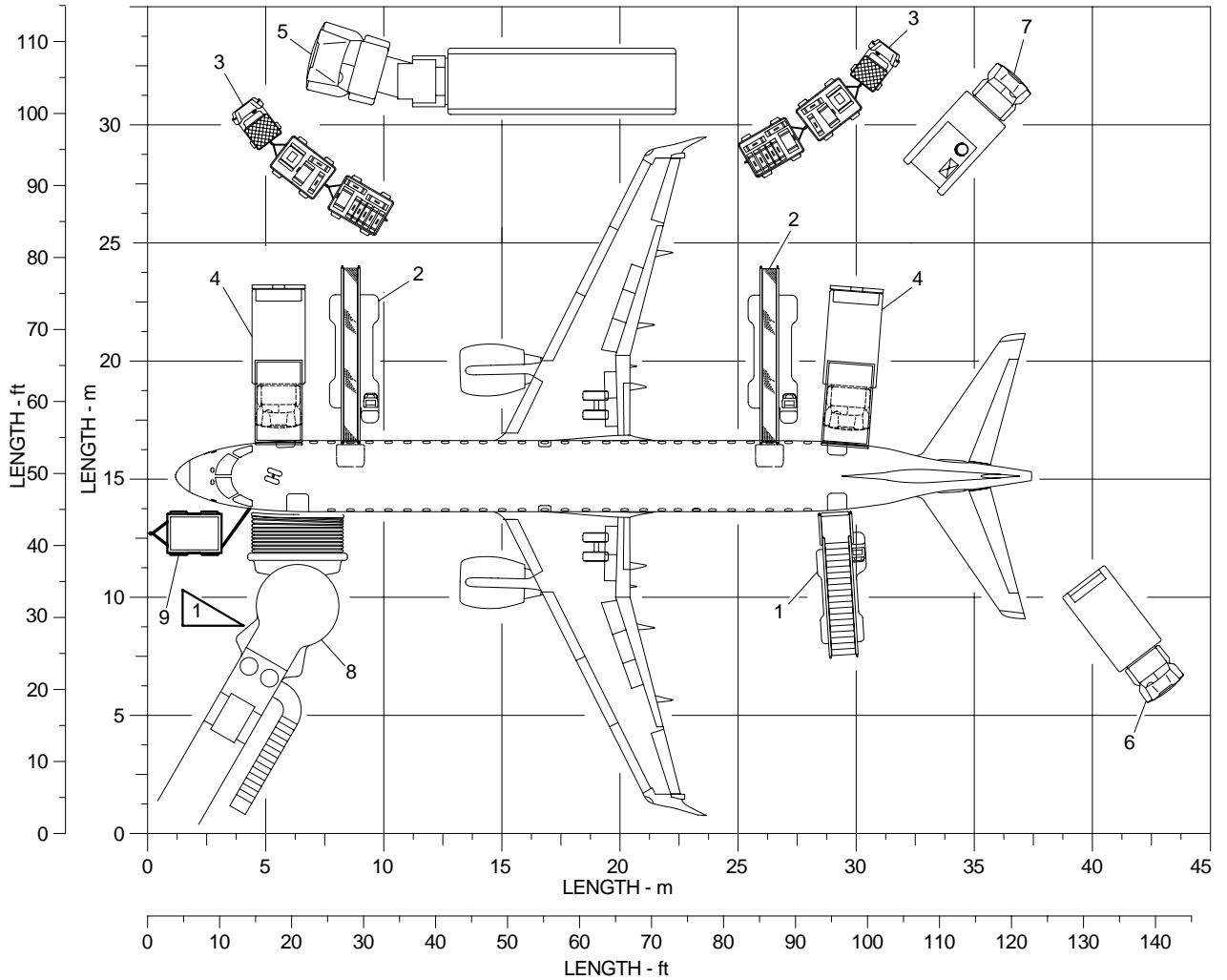

### SERVICING ARRANGEMENT

- 01 - PASSENGER STAIRS
- 02 - BAGGAGE LOADER
- 03 - BAGGAGE / CARGO
- 04 - GALLEY SERVICE
- 05 - FUEL SERVICE
- 06 - POTABLE WATER
- 07 - LAVATORY SERVICE
- 08 - PASSENGER BRIDGE
- 09 - GROUND POWER UNIT

 THE GPU CAN BE MOVED TO BETTER POSITION CONSIDERING THE GROUND CONNECTION AND THE CABLE EXTENSION.

Aircraft Servicing Arrangement With Passenger Bridge  
Figure 5.2

EIM170APM050012A.IDR

EFFECTIVITY: ALL



## **5.2. TERMINAL OPERATIONS - TURNAROUND STATION**

This section presents the typical turnaround servicing time at an air terminal. The chart gives typical schedules for performing servicing on the aircraft within a given time.

The time of each service in the chart was calculated taking the following into consideration:

- Load factor - 100%;
- Passenger deplane - 24 pax/min;
- Passenger enplane - 16 pax/min;
- Baggages checked per passenger - 1,2;
- Refuel (fuel quantity) - 80%;
- Flow - 290 gpm;
- Potable water - 70% to be refilled (56 ℓ);
- Galley service FWD and aft sequence - in parallel;
- Toilet type - vacuum;
- Baggages unloading/loading FWD/aft sequence - in parallel;
- Only FWD passenger door to be used to deplane and enplane passengers.

Servicing times could be rearranged to suit availability of personnel, aircraft configuration, and degree of servicing required.

The data illustrates the general scope and tasks involving airport terminal operations. Airline particular practices and operating experience will result in different sequences and intervals.



# EMBRAER 190 AIRPORT PLANNING MANUAL

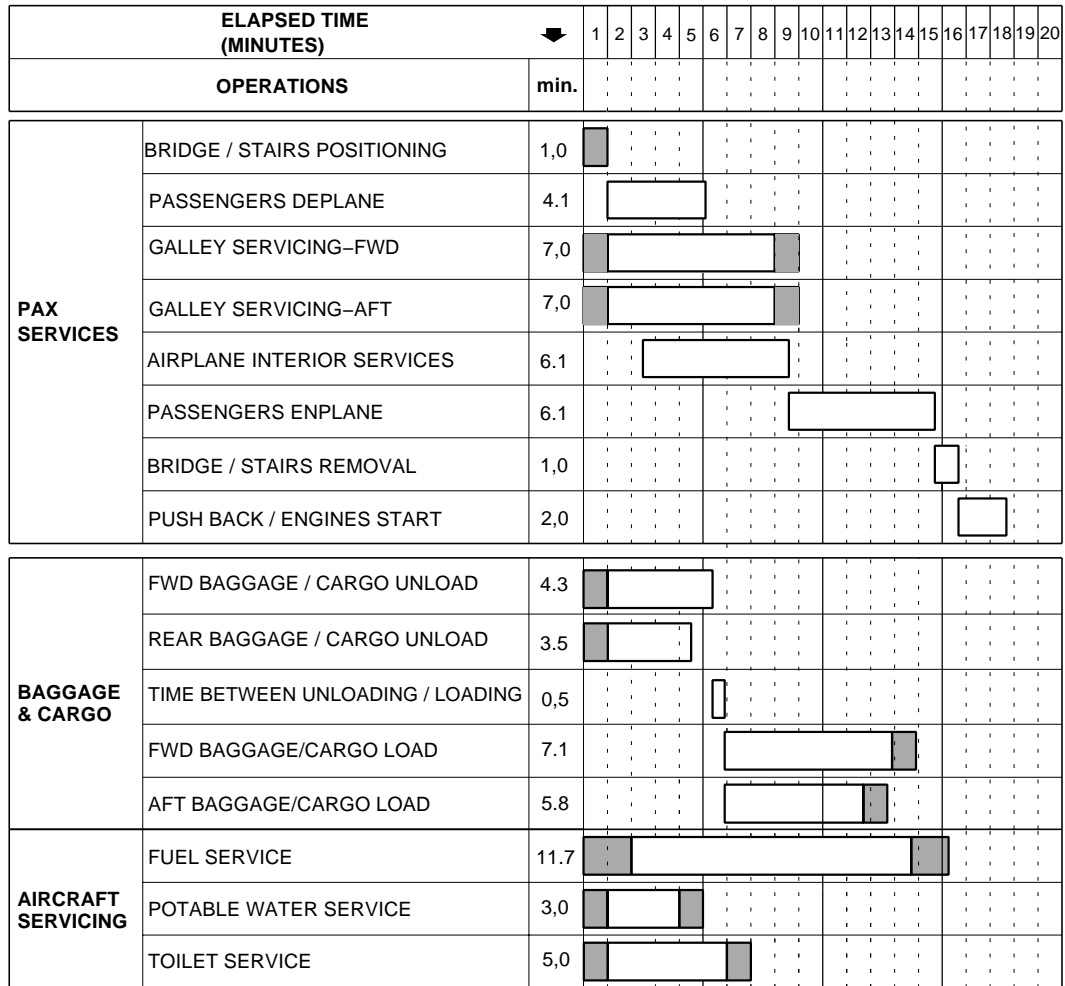

**LEGEND:**

█ TRUCK POSITIONING/REMOVAL/SETTINGS

**NOTE:**

THIS DATA ILLUSTRATES THE GENERAL SCOPE AND TASKS INVOLVING AIRPORT TERMINAL OPERATIONS. AIRLINE PARTICULAR PRACTICES AND OPERATING EXPERIENCE WILL RESULT IN DIFFERENT SEQUENCES AND INTERVALS.

Air Terminal Operation - Turnaround Station  
Figure 5.3

EM170APM050013A.DGN

EFFECTIVITY: ALL



# **EMBRAER 190** AIRPORT PLANNING MANUAL

## **5.3. TERMINAL OPERATIONS - EN ROUTE STATION**

Not Applicable

EFFECTIVITY: ALL

**Section 5**

Page 5-6

Oct 07/13



# EMBRAER 190 AIRPORT PLANNING MANUAL

## 5.4. GROUND SERVICING CONNECTIONS

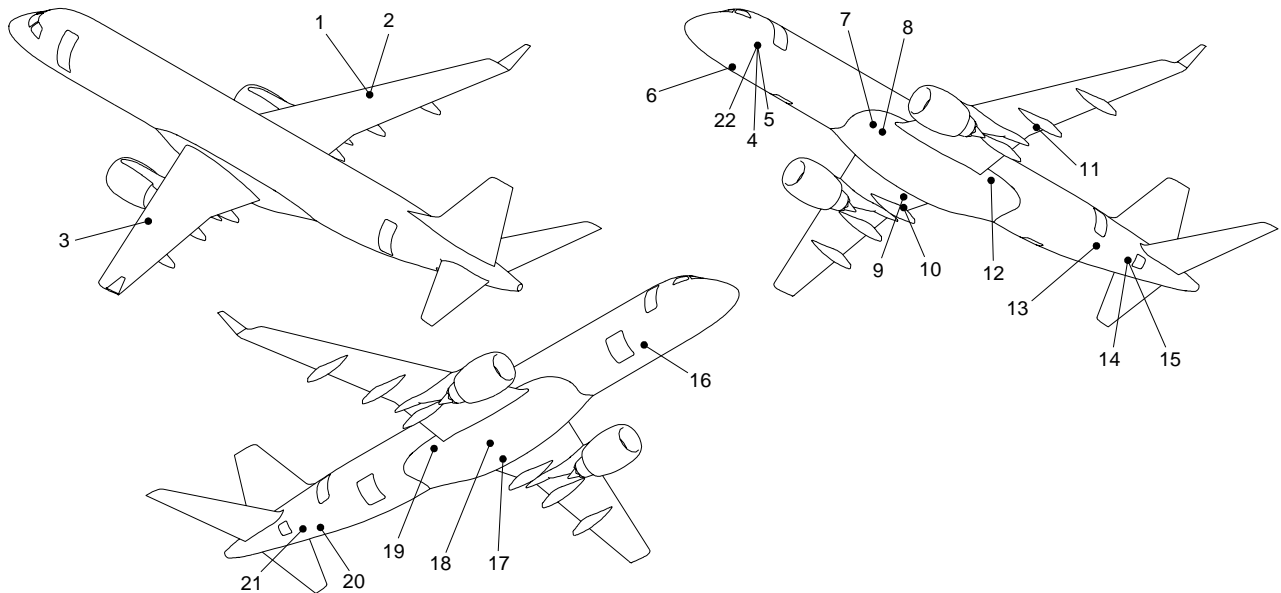

ITEM	DESCRIPTION	COORD. X (mm)	COORD. Y (mm)	COORD. Z (mm)	HEIGHT ABOVE GROUND (mm)
1	PRESSURE REFUELING PANEL	17316.95	7803.78	-543.75	2862.76
2	GRAVITY REFUELING PORT (RH)	17695.04	7774.46	-310.92	3104.19
3	GRAVITY REFUELING PORT (LH)	17932.67	-7646.75	-308.24	3112.32
4	FORWARD RAMP HEADSET	4164.44	-936.13	-1262.71	1842.51
5	STEERING SWITCH DISENGAGE	4136.97	-951.46	-1279.29	1825.31
6	WHEEL JACK POINT – NLG	4125.32	0.00	-2854.38	250.36
7	AIR COND. GROUND CONNECTION	13268.52	0.00	-1979.71	1334.39
8	ENGINE AIR STARTING (LOW PRESSURE UNIT)	13629.01	57.25	-1952.83	1369.51
9	GROUNDING POINT (ELECTRICAL)	18052.28	2930.25	-1744.67	1679.01
10	WHEEL JACK POINT– MLG (RH)	18078.03	2970.00	-2988.86	435.73
11	WHEEL JACK POINT– MLG (LH)	18078.03	-2970.00	-2988.86	435.73
12	HYD. SYS # 1 SERVICE PANEL	20139.16	-808.01	-1602.04	1869.43
13	WATER SERVICING PANEL	27861.83	-329.37	-1178.74	2469.64
14	EXTERNAL POWER SUPPLY 28 VDC / 400A	30421.65	-471.73	-605.30	3101.60
15	AFT RAMP HEADSET	30562.26	-449.47	-585.54	3124.58
16	OXYGEN SERVICING PANEL / BOTTLE	6562.14	1159.87	-961.05	2109.06
17	FUEL TANK DRAIN VALVE (LH)	16444.90	-691.60	-1611.45	1775.35
18	FUEL TANK DRAIN VALVE (RH)	16476.65	526.50	-1611.45	1776.08
19	HYD. SYS # 2 SERVICE PANEL	20139.16	808.01	-1602.04	1869.43
20	WASTE SERVICING PANEL	28784.01	349.20	-991.80	2677.66
21	HYD. SYS # 3 SERVICE PANEL	30398.86	519.15	-590.09	3116.29
22	EXTERNAL POWER SUPPLY 115 VAC	4146.90	-810.70	-1339.53	1765.31

**NOTE:**

THE GROUND CLEARANCES IN THE TABLE REFER TO THE AIRCRAFT WITH THE MINIMUM OPERATING WEIGHT (MOW) = 29500 kg (CG FWD 4.0% CMA)

EM170APM050014E.DGN

Ground Servicing Connections  
Figure 5.4

EFFECTIVITY: ALL



# EMBRAER 190 AIRPORT PLANNING MANUAL

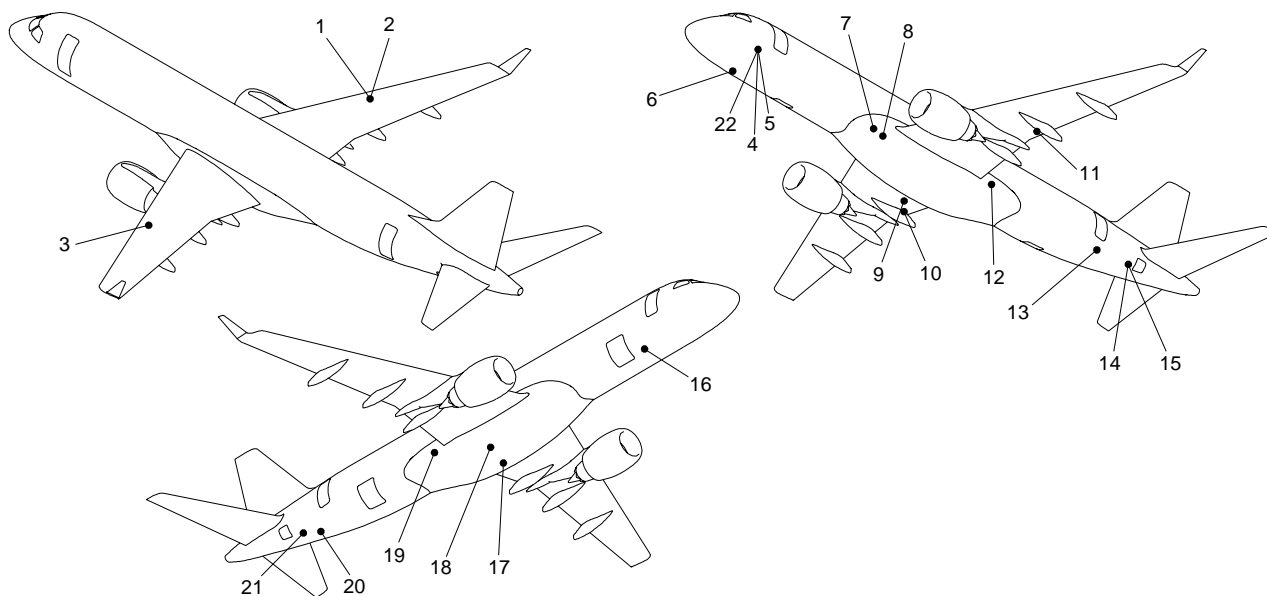

ITEM	DESCRIPTION	COORD. X (mm)	COORD. Y (mm)	COORD. Z (mm)	HEIGHT ABOVE GROUND (mm)
1	PRESSURE REFUELING PANEL	17316.95	7803.78	-543.75	2849.66
2	GRAVITY REFUELING PORT (RH)	17695.04	7774.46	-310.92	3088.37
3	GRAVITY REFUELING PORT (LH)	17932.67	-7646.75	-308.24	3094.78
4	FORWARD RAMP HEADSET	4146.44	-936.13	-1262.71	1924.92
5	STEERING SWITCH DISENGAGE	4136.97	-951.46	-1279.29	1907.92
6	WHEEL JACK POINT - NLG	4125.32	0.00	-2854.38	250.48
7	AIR COND. GROUND CONNECTION	13268.52	0.00	-1979.71	1350.51
8	ENGINE AIR STARTING (LOW PRESSURE UNIT)	13629.01	57.25	-1952.83	1383.02
9	GROUNDING POINT (ELECTRICAL)	18052.28	2930.25	-1744.67	1660.39
10	WHEEL JACK POINT- MLG (RH)	18077.02	2970.00	-2969.64	428.34
11	WHEEL JACK POINT- MLG (LH)	18077.02	-2970.00	-2969.64	428.34
12	HYD. SYS # 1 SERVICE PANEL	20139.16	-808.01	-1602.04	1835.66
13	WATER SERVICING PANEL	27861.83	-329.37	-1178.74	2379.79
14	EXTERNAL POWER SUPPLY 28 VDC / 400A	30421.65	-471.73	-605.30	2993.22
15	AFT RAMP HEADSET	30562.26	-449.47	-585.54	3015.18
16	OXYGEN SERVICING PANEL / BOTTLE	6562.14	1159.87	-961.05	2264.08
17	FUEL TANK DRAIN VALVE (LH)	16444.90	-691.60	-1611.45	1768.43
18	FUEL TANK DRAIN VALVE (RH)	16476.65	526.50	-1611.45	1768.43
19	HYD. SYS # 2 SERVICE PANEL	20139.16	808.01	-1602.04	1835.66
20	WASTE SERVICING PANEL	28784.01	349.20	-991.80	2581.13
21	HYD. SYS # 3 SERVICE PANEL	30398.86	519.15	-590.09	3008.07
22	EXTERNAL POWER SUPPLY 115 VAC	4146.90	-810.70	-1339.53	1847.84

**NOTE:**

THE GROUND CLEARANCES IN THE TABLE REFER TO THE AIRCRAFT WITH THE MINIMUM OPERATING WEIGHT (MOW) = 29500 kg (CG REAR 29.0% CMA)

EM170APM050024.DGN

Ground Servicing Connections  
Figure 5.5

EFFECTIVITY: ALL



**5.5. ENGINE STARTING PNEUMATIC REQUIREMENTS**

TABLE 1 – PNEUMATIC ENGINE START REQUIREMENTS

Altitude ft	Ambient Temp		Minimum Pressure psia	Minimum Flow lb/min
	°C	(°F)		
SL	-40	(-40)	48.0	95.1
SL	15	(59)	43.7	82.0
SL	49	(120)	40.7	73.7
9000	-40	(-40)	37.7	74.5
9000	- 5	(23)	30.0	57.3
9000	13	(86)	28.9	53.4
13,000	-40	(-40)	36.0	71.3
13,000	-11	(12)	27.2	52.2
13,000	21.7	(71)	26.7	49.6
15,000	-40	(-40)	32.9	66.6
15,000	-15	(5)	25.3	49.0
15,000	15	(59)	24.4	46.1

Engine Starting Pneumatic Requirements  
Figure 5.6

EFFECTIVITY: ALL

EM170APM050030B.DGN



# EMBRAER 190 AIRPORT PLANNING MANUAL

## 5.6. GROUND PNEUMATIC POWER REQUIREMENTS

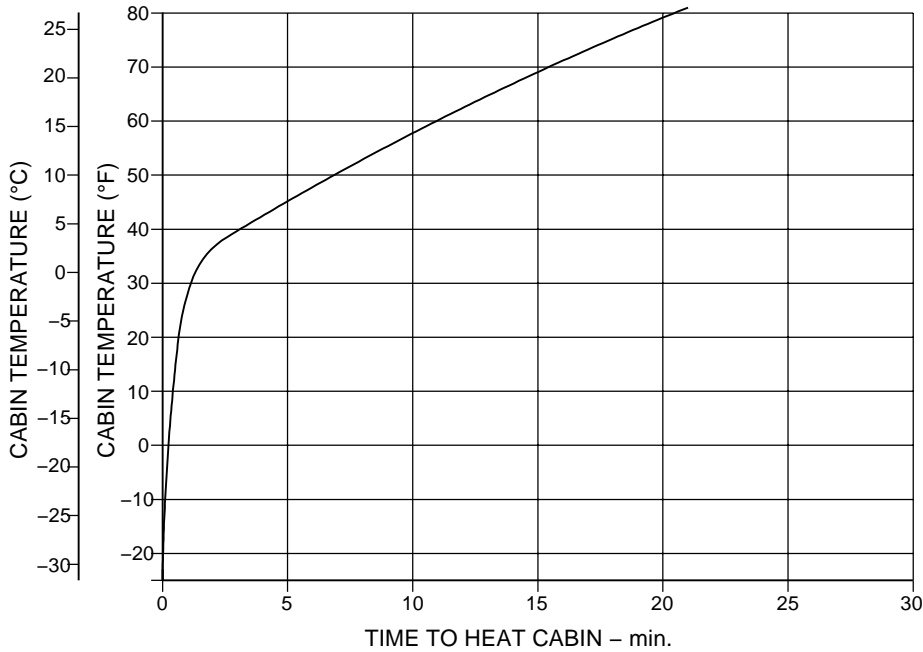

### HEATING

Initial cabin temp: -32°C (-25°F)  
 Outside air temp: -40°C (-40°F)  
 Relative Humidity: 0%  
 No crew or passengers  
 No other heat load

Bleed air from APU:  
 87 kg/min. (192.0 lb/min.)  
 452 kPa (65.5 psia)  
 2 operating packs (ECS)

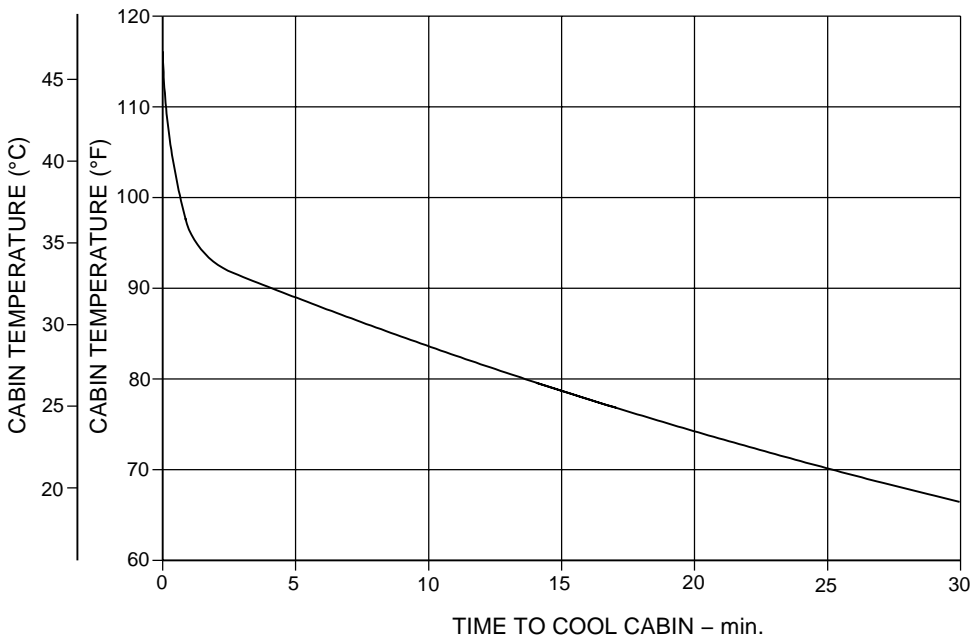

### COOLING

Initial cabin temp: 47°C (116°F)  
 Outside air temp: 40°C (104°F)  
 Relative Humidity: 40%  
 No crew or passengers  
 No other heat load

Bleed air from APU:  
 56 kg/min. (122.9 lb/min.)  
 413 kPa (59.9 psia)  
 2 operating packs (ECS)

EM170APM050007B.DGN

Ground Pneumatic Power Requirements  
 Figure 5.7

EFFECTIVITY: ALL





**5.7. PRECONDITIONED AIRFLOW REQUIREMENTS**

This subsection presents the following information:

- The air conditioning requirements for heating and cooling using ground conditioned air. The curves show airflow requirements to heat or cool the aircraft within a given time at ambient conditions.
- The air conditioning requirements for heating and cooling to maintain a constant cabin air temperature using low-pressure conditioned air. This conditioned air is supplied through a ground air connection directly to the passenger cabin, bypassing the air cycle machines.



# EMBRAER 190 AIRPORT PLANNING MANUAL

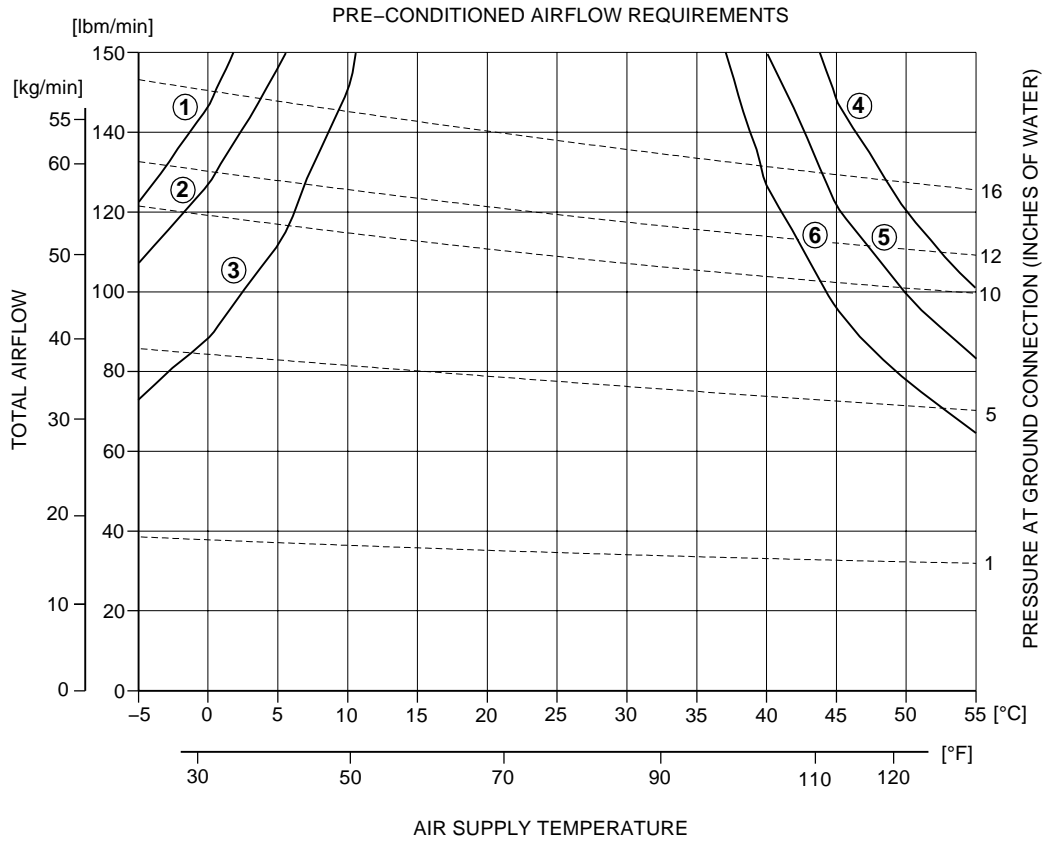

**LEGEND:**

- ① CABIN AT 24°C (74°F), 97 OCCUPANTS, BRIGHT DAY (SOLAR IRRADIATION), 39°C (103°F) DAY.
- ② SAME AS 1 EXCEPT CABIN 27°C (81°F)
- ③ SAME AS 1 EXCEPT CABIN 24°C (74°F), NO CABIN OCCUPANTS, FOUR CREWS MEMBERS ONLY.
- ④ CABIN AT 24°C (74°F), NO CABIN OCCUPANTS, FOUR CREW MEMBERS ONLY, OVERCAST DAY (NO SOLAR IRRADIATION), -40°C (-40°F) DAY.
- ⑤ SAME AS 4 EXCEPT -29°C (-20°F) DAY.
- ⑥ SAME AS 4 EXCEPT -18°C (-0°F) DAY.

**NOTES:**

MAXIMUM ALLOWABLE TEMPERATURE 88°C (190°F) (UPPER LIMIT DURING PULL UP OPERATION).

MAXIMUM ALLOWABLE PRESSURE AT GROUND CONNECTION 406mmH2O (16 INCHES OF WATER).

EM170MFEFP040070B.DGN

Preconditioned Airflow Requirements  
Figure 5.8

EFFECTIVITY: ALL



**5.8. GROUND TOWING REQUIREMENTS**

**GROUND PUSHBACK / TOWING REQUIREMENTS**

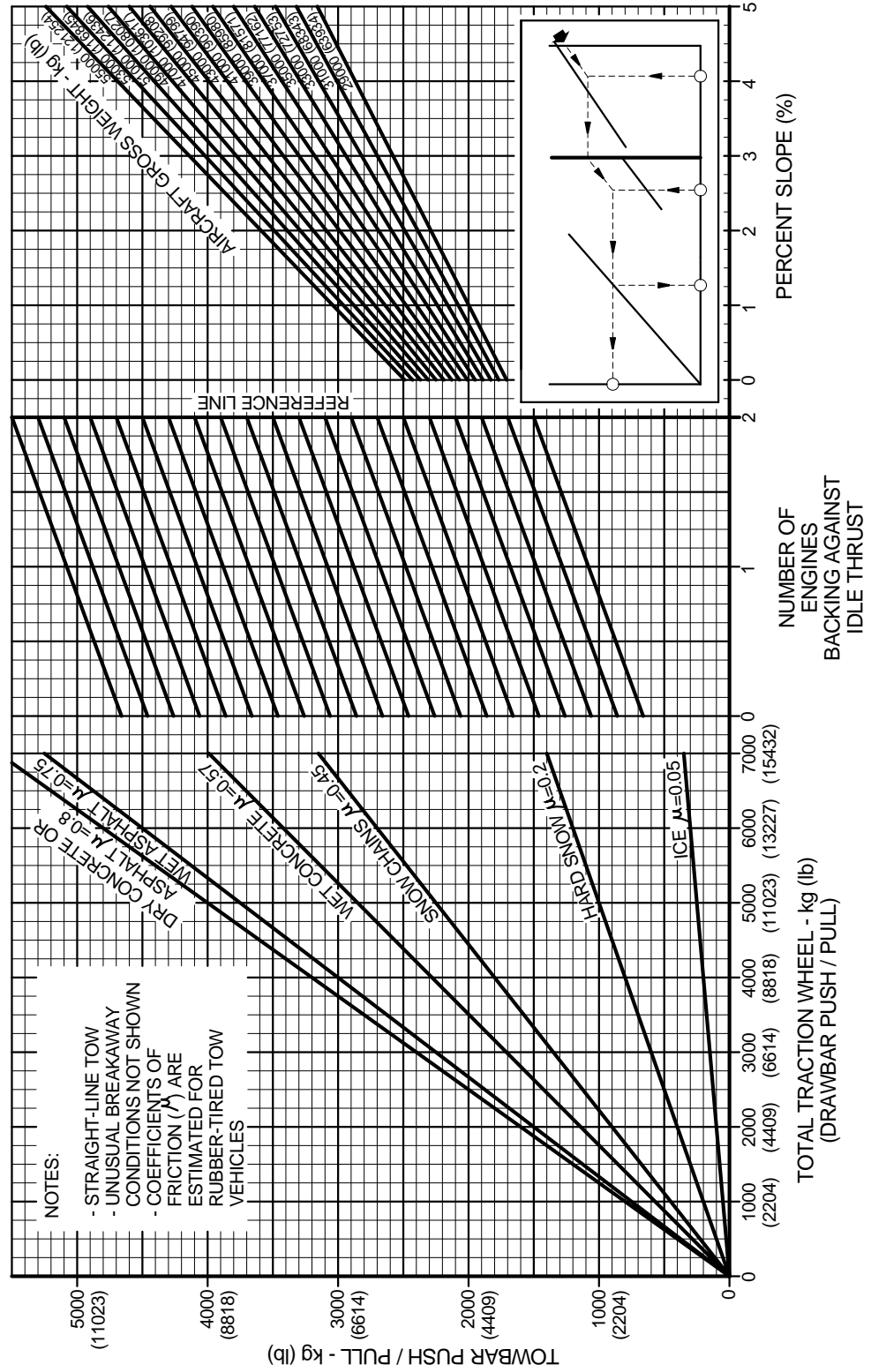

Ground Towing Requirements  
Figure 5.9

EM170MFEP040066C.IDR

EFFECTIVITY: ALL





## 6. OPERATING CONDITIONS

This section provides the following information:

- The jet engine exhaust velocities and temperatures;
- The airport and community noise levels;
- The hazard areas.



# EMBRAER 190 AIRPORT PLANNING MANUAL

## 6.1. ENGINE EXHAUST VELOCITIES AND TEMPERATURES

TAKEOFF POWER, SEA LEVEL, T<sub>amb</sub> = ISA +20°C, FNIN1 = 84347 N (18962 lbf)

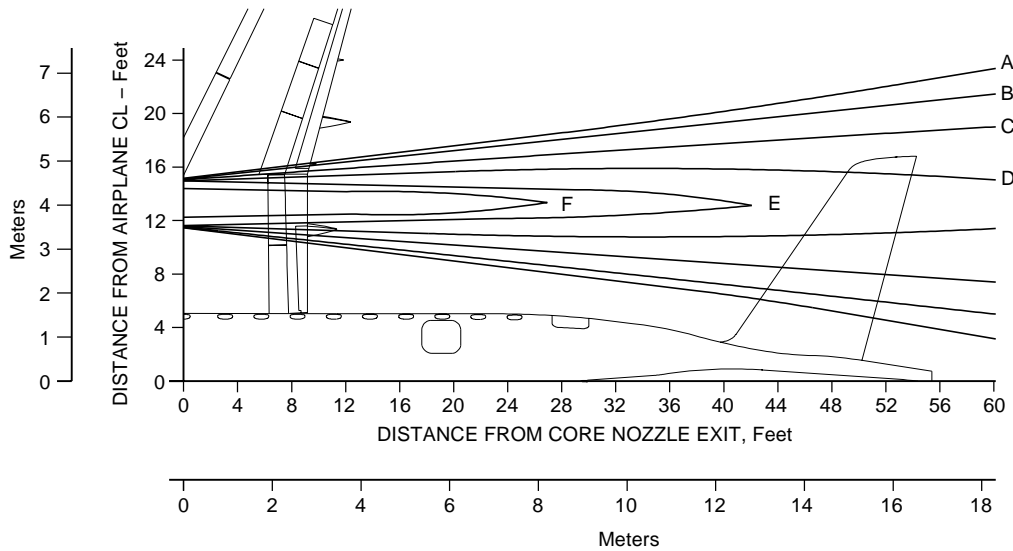
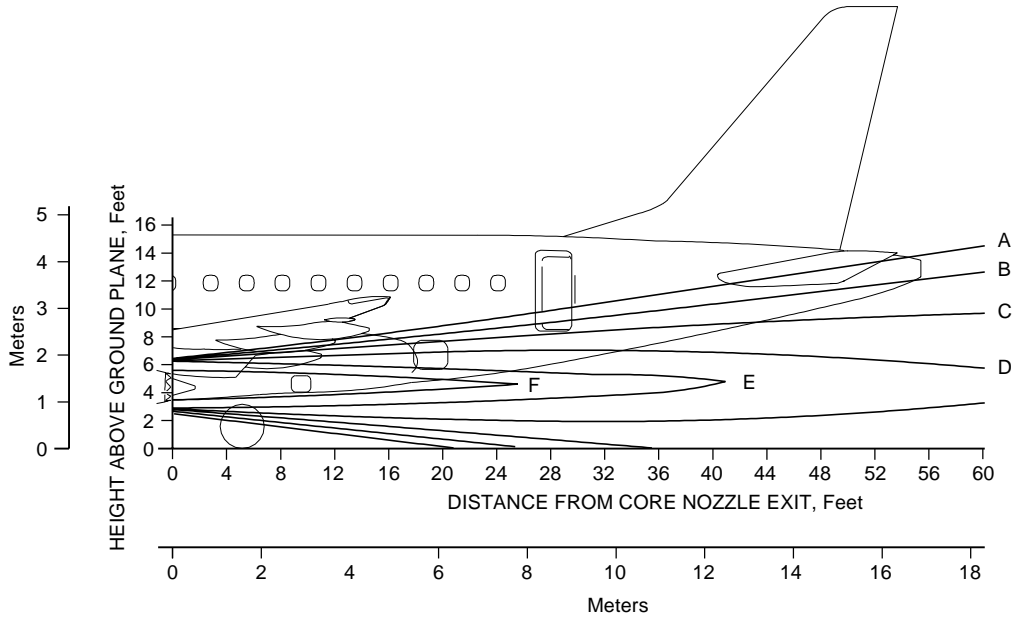

VELOCITY m/s (ft/s)	
MAX = 482.5 (1583)	
A	15.2 (50)
B	30.5 (100)
C	60.9 (200)
D	121.9 (400)
E	243.8 (800)
F	396.2 (1300)

**NOTE:**  
EXHAUST VELOCITY CONTOURS INCLUDE WORST CASE 20 kn HEADWIND WITH GROUND EFFECTS.

EM170MFEF020014A.DGN

Jet Wake Velocity Profile - Takeoff Power  
Figure 6.1

EFFECTIVITY: ALL



# EMBRAER 190 AIRPORT PLANNING MANUAL

TAKEOFF POWER, SEA LEVEL, Tamb = ISA +20°C, FNIN1 = 84347 N (18962 lbf)

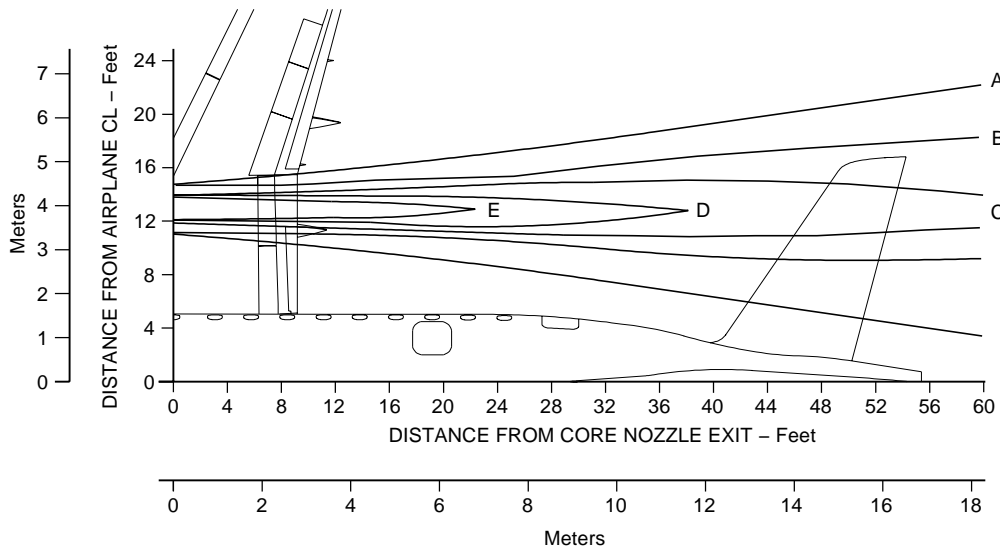
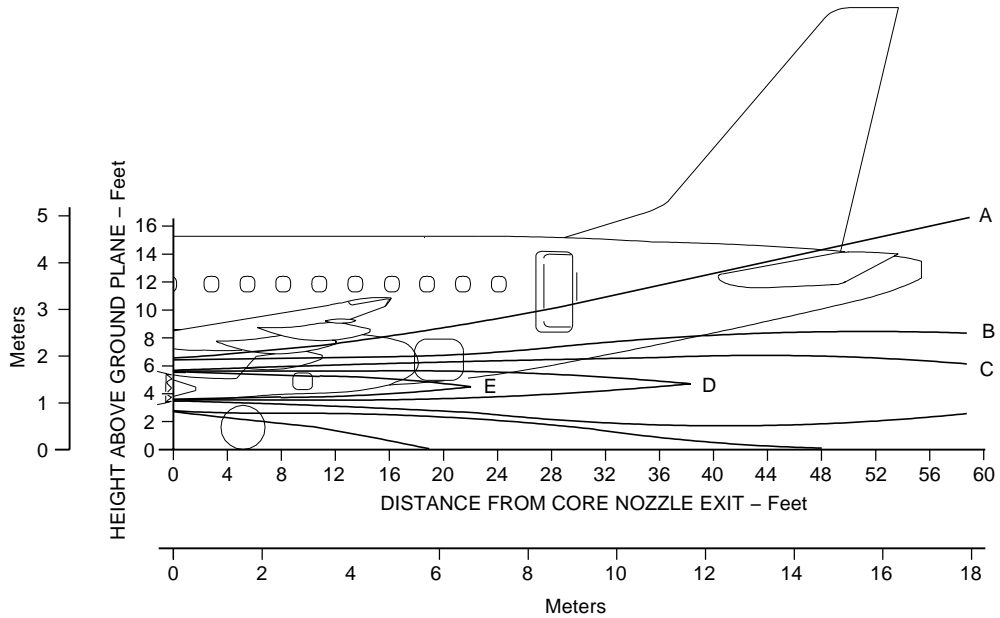

TOTAL TEMPERATURE MAX = 689°C (1273°F)		
	°C	°F
A	38	100
B	66	150
C	93	200
D	204	400
E	582	900

**NOTE:**  
EXHAUST TEMPERATURE CONTOURS INCLUDE WORST CASE 20 kn HEADWIND.

Jet Wake Temperature Profile - Takeoff Power  
Figure 6.2

EM170MFEP020016B.DGN

EFFECTIVITY: ALL



# EMBRAER 190 AIRPORT PLANNING MANUAL

**GROUND IDLE, SEA LEVEL, Tamb = ISA +15°C, FNIN1 = 2558 N (575 lbf)**

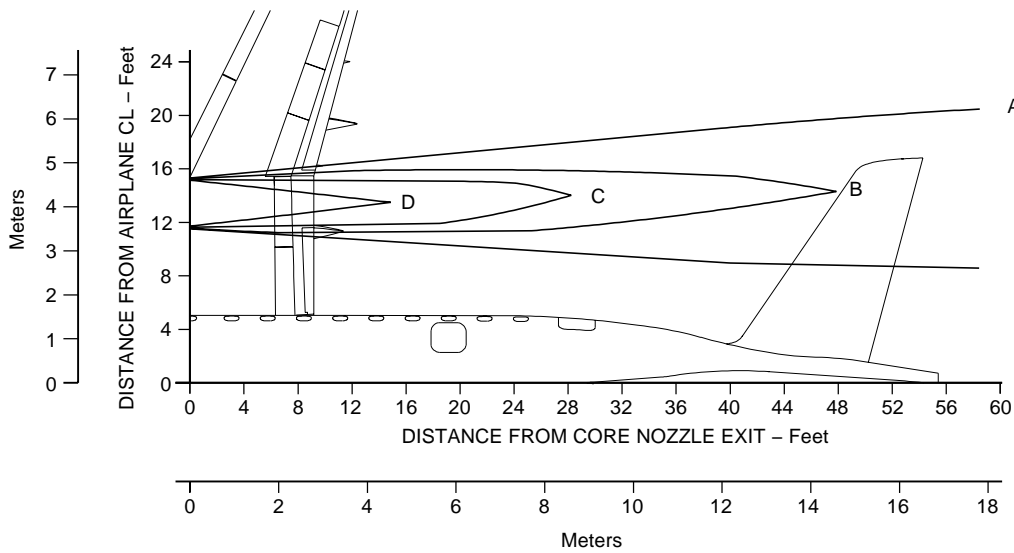
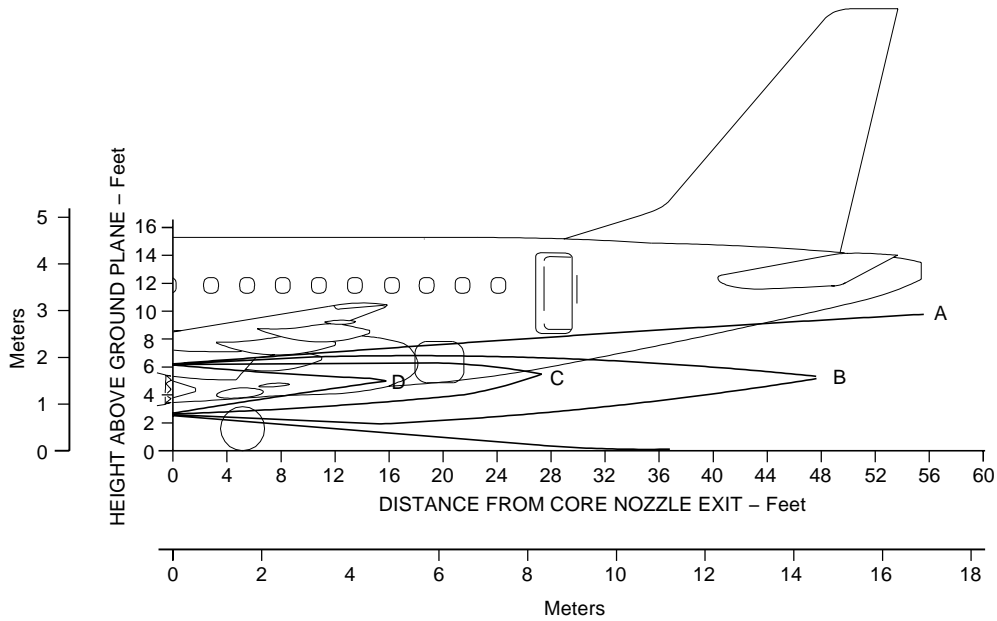

VELOCITY m/s (ft/s)	
<b>MAX = 89.0 (292)</b>	
A	15.2 (50)
B	30.5 (100)
C	45.7 (150)
D	57.9 (190)

**NOTE:**  
EXHAUST VELOCITY CONTOURS INCLUDE WORST CASE 20 kn HEADWIND WITH GROUND EFFECTS.

EM170MFE020015A.DGN

Jet Wake Velocity Profile - Ground Idle  
Figure 6.3

EFFECTIVITY: ALL





# EMBRAER 190 AIRPORT PLANNING MANUAL

GROUND IDLE, SEA LEVEL, Tamb = ISA +15°C, FNIN1 = 2558 N (575 lbf)

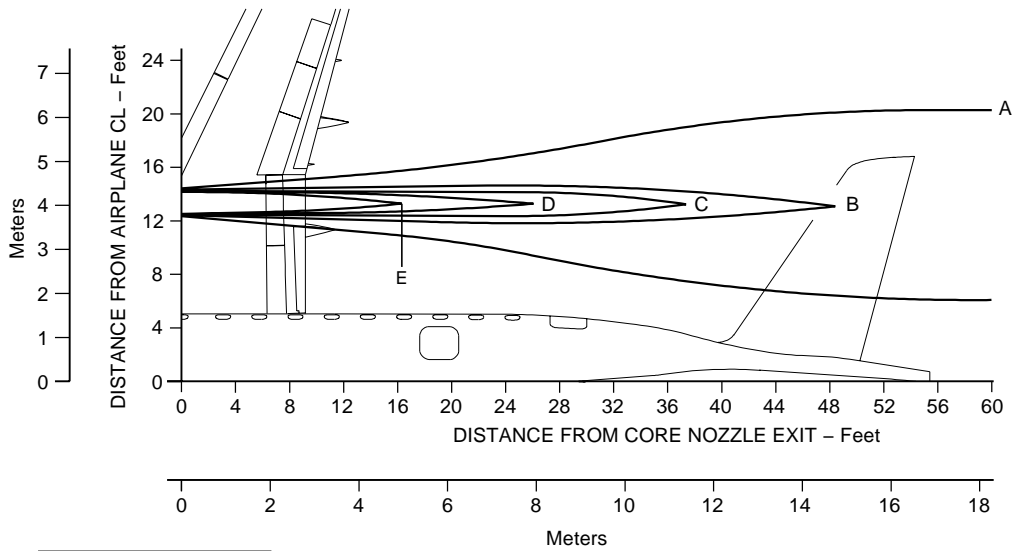
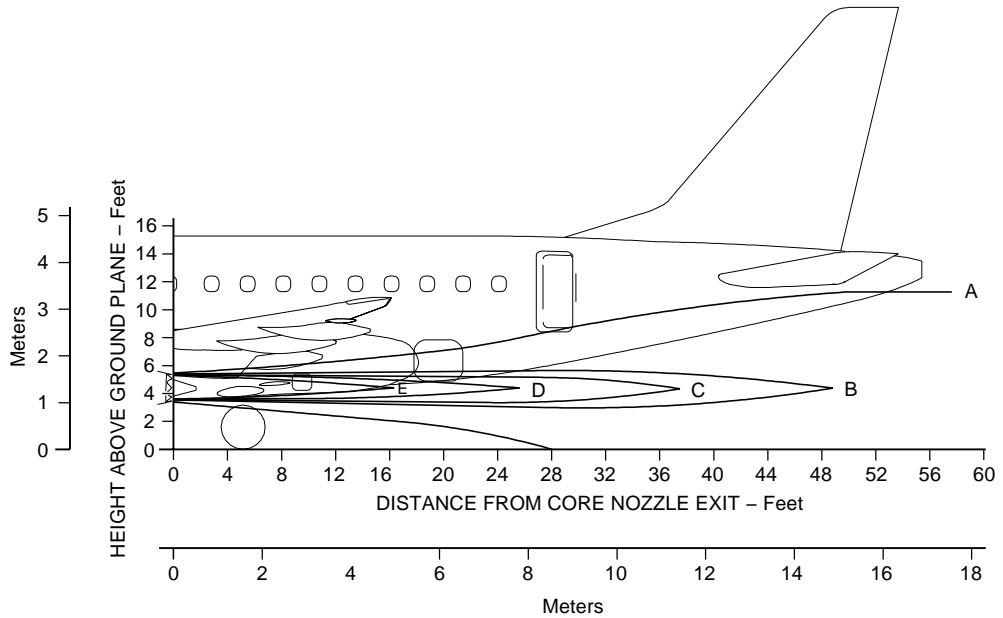

TOTAL TEMPERATURE MAX = 519°C (966°F)		
	°C	°F
A	38	100
B	66	150
C	93	200
D	204	400
E	582	900

**NOTE:**  
EXHAUST TEMPERATURE CONTOURS INCLUDE WORST CASE 20 kn HEADWIND.

Jet Wake Temperature Profile - Ground Idle  
Figure 6.4

EM170MFEP020017A.DGN

EFFECTIVITY: ALL



# EMBRAER 190 AIRPORT PLANNING MANUAL

BREAKAWAY POWER, SEA LEVEL, Tamb = ISA +0°C, FNIN1 = 40660 N (9139 lbf)

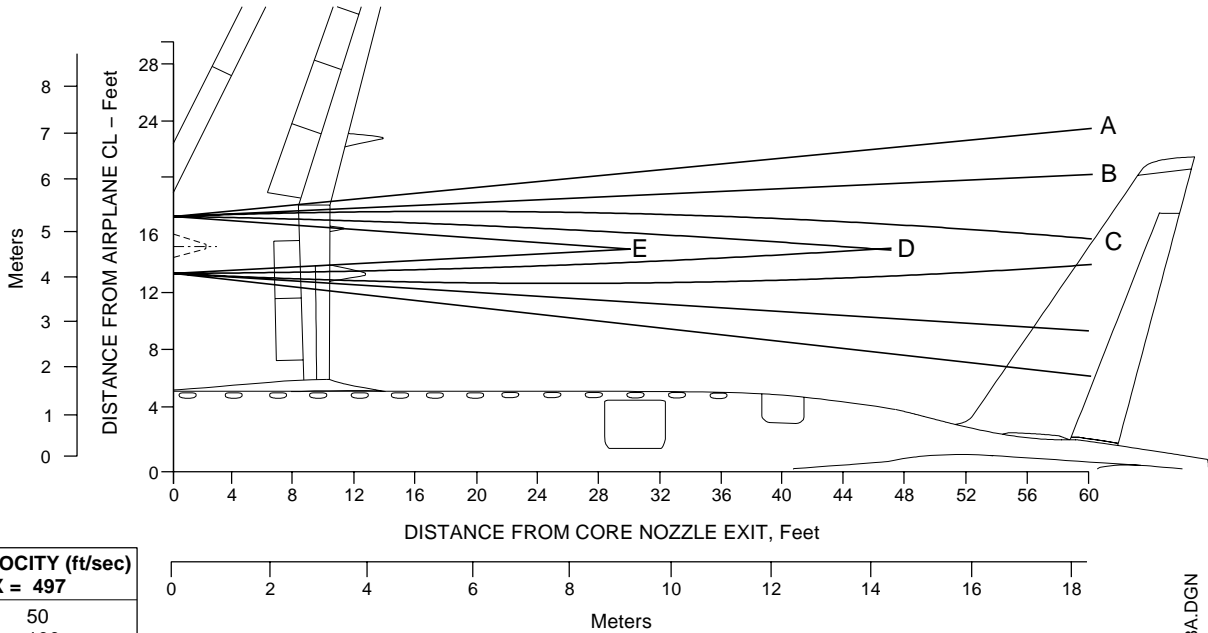
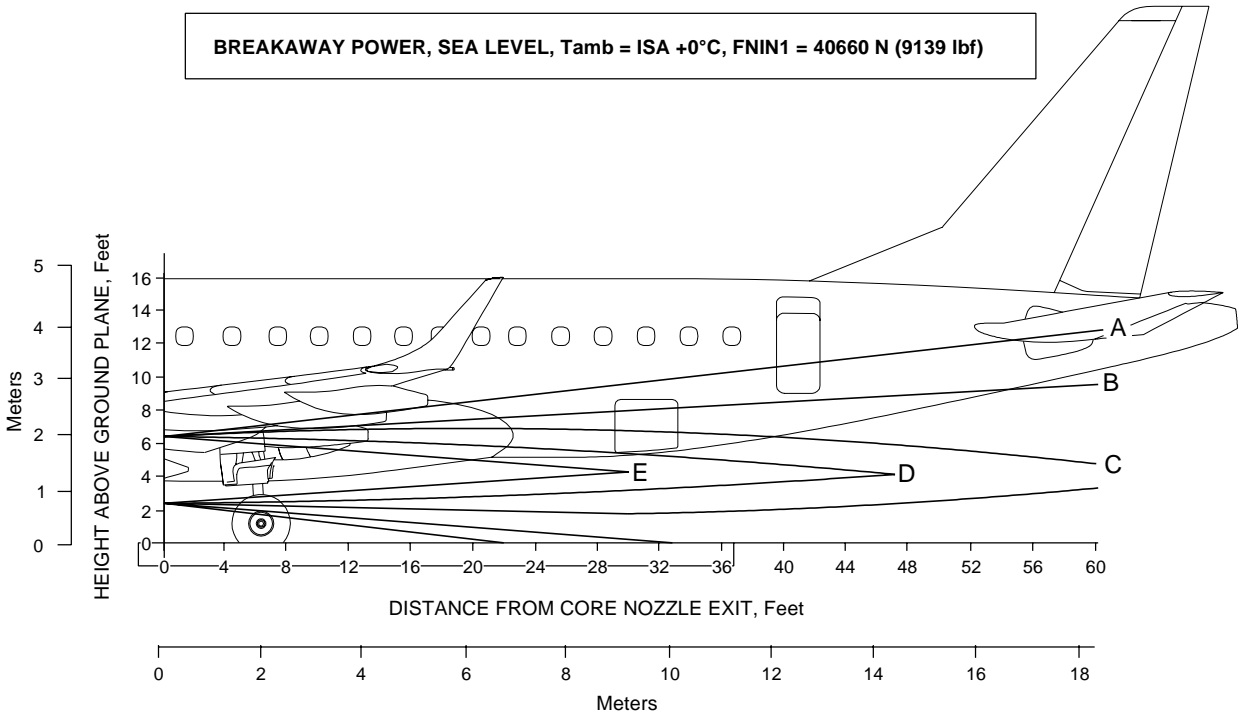

VELOCITY (ft/sec)	
MAX = 497	
A	50
B	100
C	200
D	300
E	450

**NOTE:**  
EXHAUST VELOCITY CONTOURS INCLUDE WORST CASE 20 knot HEADWIND WITH GROUND EFFECTS.

EM170APM060008A.DGN

Jet Wake Velocity Profile - Breakaway Power  
Figure 6.5  
Sheet 1

EFFECTIVITY: ALL



# EMBRAER 190 AIRPORT PLANNING MANUAL

BREAKAWAY POWER, SEA LEVEL, Tamb = ISA +0°C, FNIN1 = 40660 N (9139 lbf)

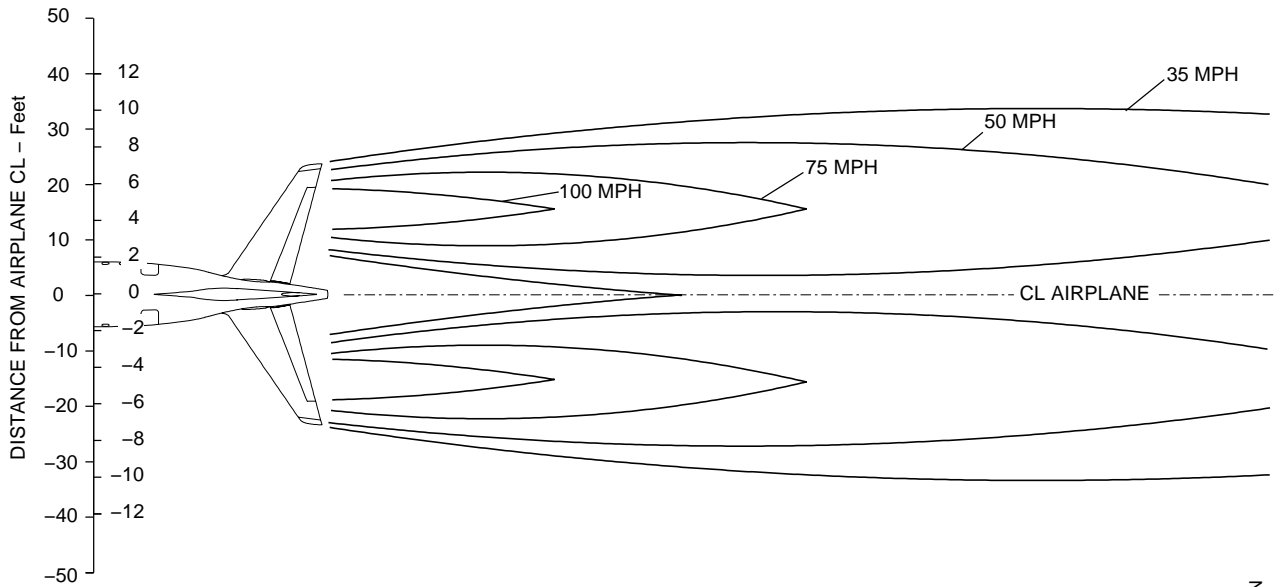
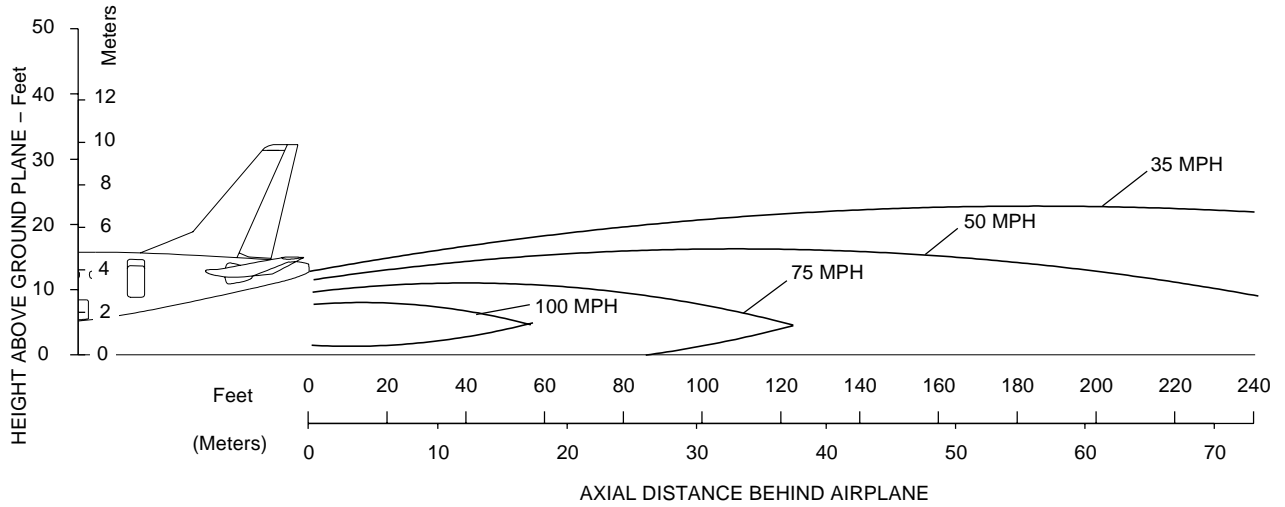

EM170APM060010A.DGN

Jet Wake Velocity Profile - Breakaway Power  
Figure 6.5  
Sheet 2

EFFECTIVITY: ALL



# EMBRAER 190 AIRPORT PLANNING MANUAL

BREAKAWAY POWER, SEA LEVEL, Tamb = ISA +0°C, FNIN1 = 40660 N (9139 lbf)

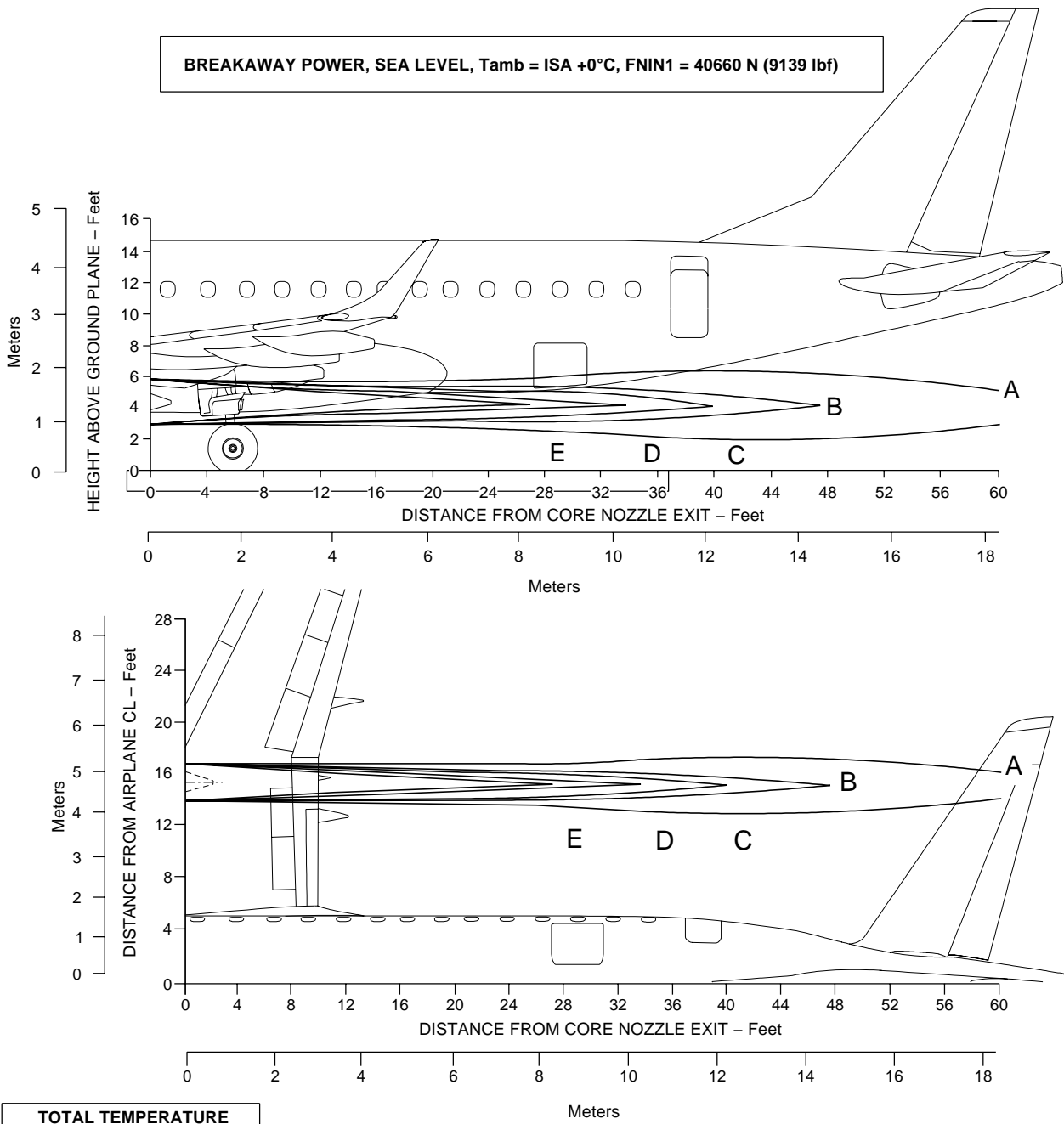

TOTAL TEMPERATURE MAX = 697 °F (369 °C)		
	°F	°C
A	100	38
B	150	66
C	200	93
D	400	204
E	650	343

**NOTE:**  
EXHAUST TEMPERATURE CONTOURS INCLUDE WORST CASE 20 knot HEADWIND.

Jet Wake Temperature Profile - Breakaway Power  
Figure 6.6

EM170APM060009A.DGN



## **6.2. AIRPORT AND COMMUNITY NOISE**

Aircraft noise is a major concern for the airport and community planner. The airport is a basic element in the community's transportation system and, thus, is vital to its growth. However, the airport must also be a good neighbor, and this can only be accomplished with proper planning. Since aircraft noise extends beyond the boundaries of the airport, it is vital to consider the noise impact on the surrounding communities.

Many means have been devised to provide the planner with a tool to estimate the impact of airport operations. Too often they oversimplify noise to the point where the results become erroneous. Noise is not a simple matter; therefore, there are no simple answers.

The cumulative noise contour is an effective tool. However, care must be exercised to ensure that the contours, used correctly, estimate the noise resulting from aircraft operations conducted at an airport. The size and shape of the single-event contours, which are inputs into the cumulative noise contours, are dependent upon numerous factors. They include operational factors (aircraft weight, engine power setting, airport altitude), atmospheric conditions (wind, temperature, relative humidity, surface condition), and terrain.

### **6.2.1. External Certification Noise Levels**

The aircraft comply with the Stage 3 / Chapter 3 noise limits set forth in 14 CFR Part 36, ICAO Annex 16, Volume 1, Chapter 3, Amendment 7 and CTA RBHA 36.

### **6.2.2. Ramp Noise Levels**

The ramp noise will not exceed 80 dBA (maximum) and 77 dBA (average) on the rectangular perimeter of 20 m (65 ft 7 in) from the aircraft centerline, nose and tail, 90 dBA on the service positions and 80 dBA on the passenger entrance positions resulting from operation of the APU (if fitted), ECS, equipment cooling fans and vent fans, in any combination.



## 6.3. HAZARD AREAS

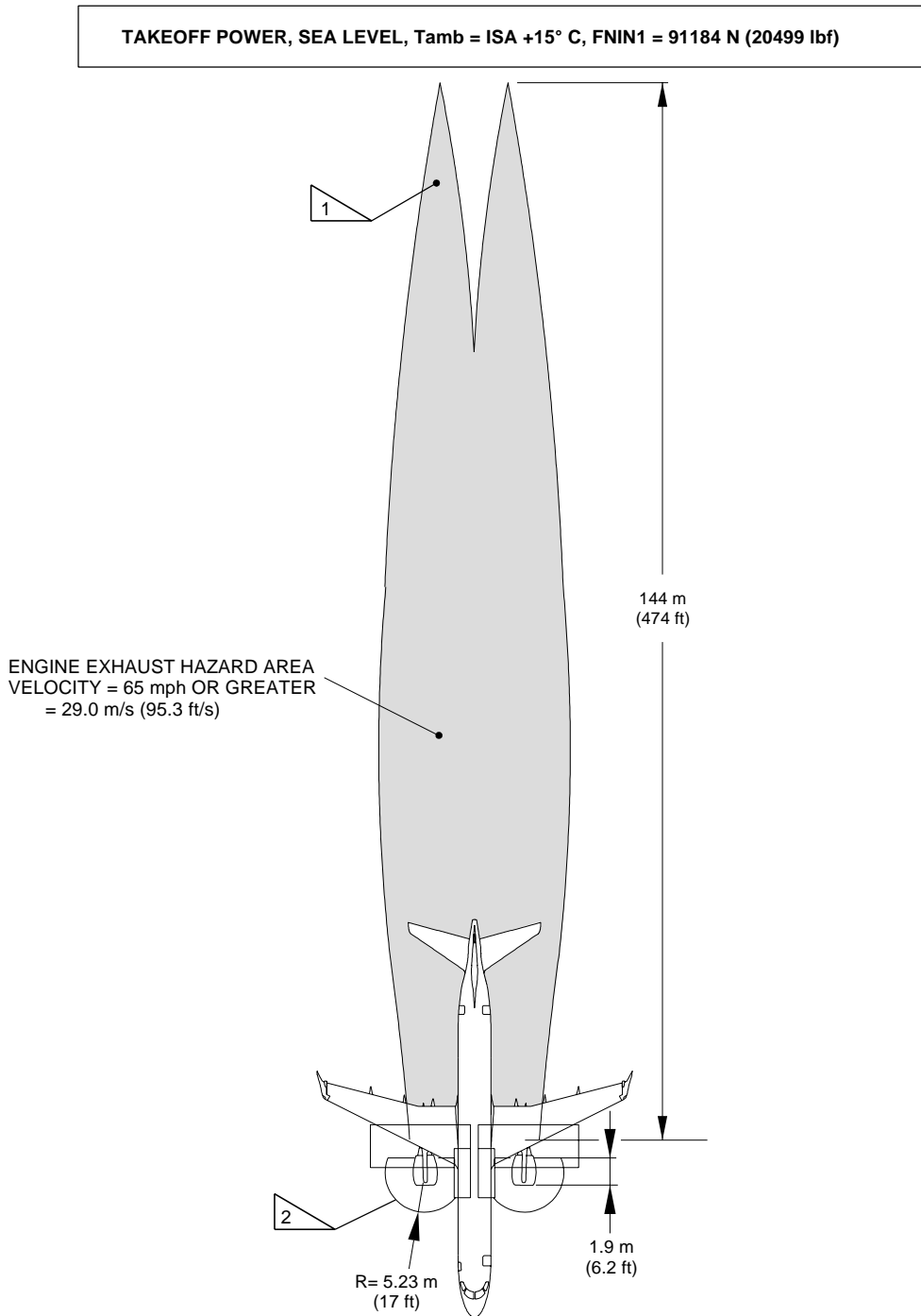

**NOTE:**  
NO ACCESS TO ENGINE ACCESSORIES AT TAKEOFF POWER.

1 EXHAUST HAZARD AREA – CONDITION: 20 kn HEADWIND WITH GROUND EFFECTS.

2 INLET HAZARD AREA – CONDITION: 20 kn HEADWIND/CROSSWIND BASED ON 12.2 m/s (40 ft/s) CRITICAL VELOCITY WITH 0.9 m (3 ft) CONTINGENCY FACTOR.

EM170APM060004B.DGN

Hazard Areas - Takeoff Power  
Figure 6.7

EFFECTIVITY: ALL



# EMBRAER 190 AIRPORT PLANNING MANUAL

GROUND IDLE, SEA LEVEL, Tamb = ISA+15° C, FNIN1 = 3768 N (847 lbf)

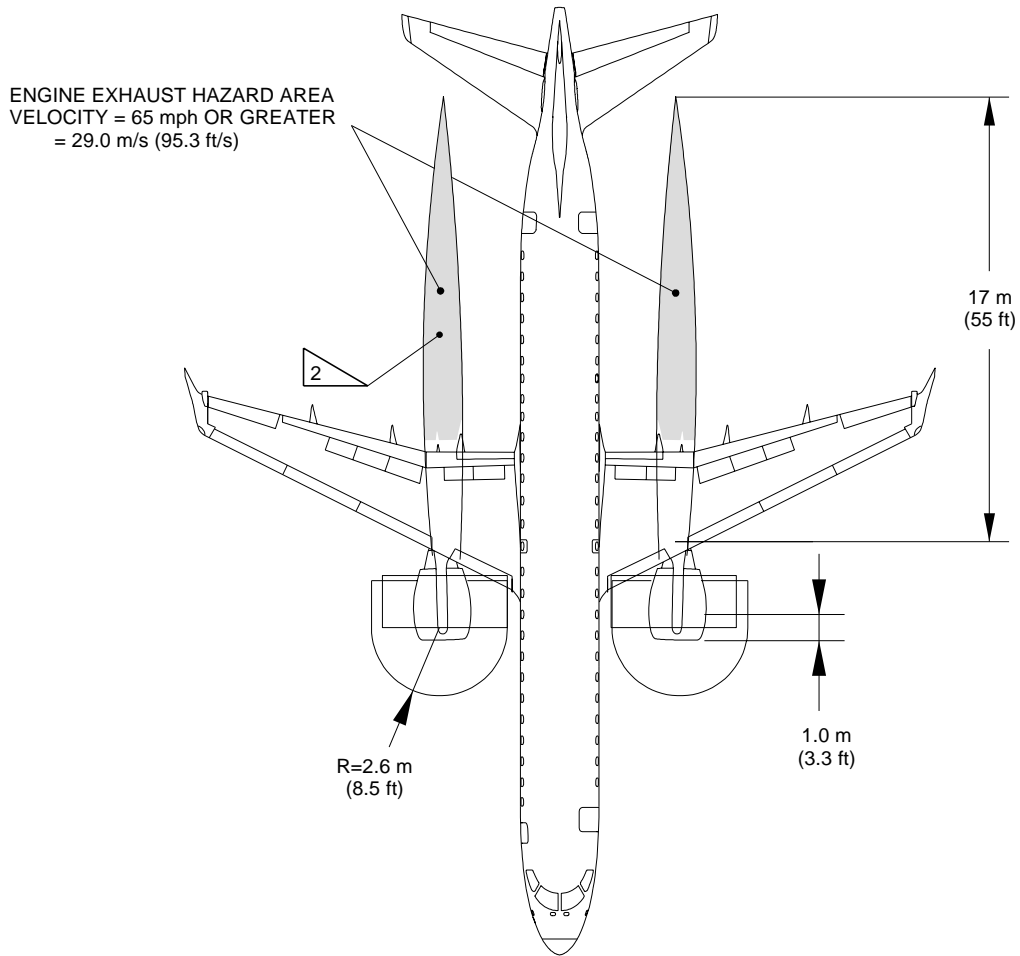

1 INLET HAZARD AREA – CONDITION: 20 kn HEADWIND/CROSSWIND/TAILWIND BASED ON 12.2 m/s (40 ft/s) CRITICAL VELOCITY WITH 0.9 m (3 ft) CONTINGENCY FACTOR.

2 EXHAUST HAZARD AREA – CONDITION: 20 kn HEADWIND WITH GROUND EFFECTS.

Hazard Areas - Ground Idle  
Figure 6.8

EM170APM060005C.DGN

EFFECTIVITY: ALL







## **7. PAVEMENT DATA**

### **7.1. GENERAL INFORMATION**

Pavement is defined as a structure consisting of one or more layers of processed materials.

The primary function of a pavement is to distribute concentrated loads so that the supporting capacity of the subgrade soil is not exceeded. The subgrade soil is defined as the material on which the pavement rests, whether embankment or excavation.

Several methods for design of airport pavements have been developed that differ considerably in their approach.

The design methods are derived from observation of pavements in service or experimental pavements. Thus, the reliability of any method is proportional to the amount of experimental verification behind the method, and all methods require a considerable amount of common sense and judgment on the part of the engineer who applies them.

A brief description of the following pavement charts will be helpful in their use for airport planning. Each aircraft configuration is depicted with a minimum range of five loads imposed on the main landing gear to aid in the interpolation between the discrete values shown. The tire pressure used for the aircraft charts will produce the recommended tire deflection with the aircraft loaded to its maximum ramp weight and with center of gravity position. The tire pressure, where specifically designated in tables and on charts, are values obtained under loaded conditions as certificated for commercial use.

This section is presented as follows:

- The basic data on the landing gear footprint configuration, maximum design ramp loads, and tire sizes and pressures.
- The maximum pavement loads for certain critical conditions at the tire-ground interfaces.
- A chart in order to determine the loads throughout the stability limits of the aircraft at rest on the pavement. Pavement requirements for commercial aircraft are customarily derived from the static analysis of loads imposed on the main landing gear struts. These main landing gear loads are used to enter the pavement design charts which follow, interpolating load values where necessary.
- The flexible pavement curves prepared in accordance with the US Army Corps of Engineers Design Method and the LCN Method.
- The rigid pavement design curves in accordance with the Portland Cement Association Design Method and the LCN Method.
- The aircraft ACN values for flexible and rigid pavements.



# EMBRAER 190 AIRPORT PLANNING MANUAL

## 7.2. FOOTPRINT

	AIRCRAFT MODELS		
	STD	LR	AR
MAXIMUM RAMP WEIGHT	47950 kg (105712 lb)	50460 kg (111245 lb)	51960 kg (114552 lb)
NOSE GEAR TIRE SIZE	24 x 7.7 16PR		
NOSE GEAR TIRE PRESSURE	9.21 – 0/+0.7 kg/cm <sup>2</sup> (131 – 0/+10 psi)		
MAIN GEAR TIRE SIZE	H41 x 16–20 22PR		
MAIN GEAR TIRE PRESSURE	10.34 – 0/+0.7 kg/cm <sup>2</sup> (147 – 0/+10 psi)		

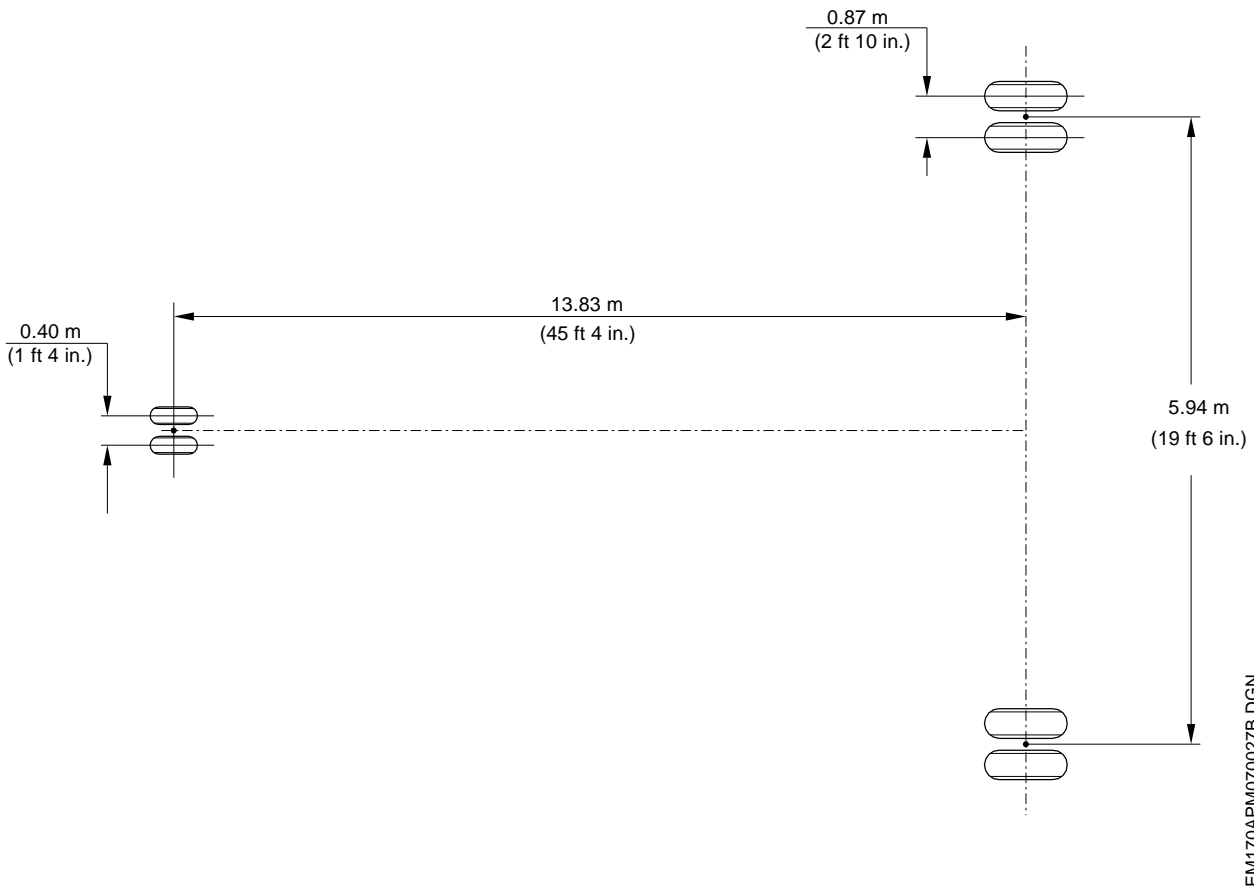

Footprint  
Figure 7.1

EFFECTIVITY: ALL

Section 7

Page 7-2

Oct 07/13



# EMBRAER 190 AIRPORT PLANNING MANUAL

## 7.3. MAXIMUM PAVEMENT LOADS

LEGEND:  $V_{NG}$  =MAXIMUM VERTICAL NOSE GEAR GROUND LOAD AT MOST FORWARD C.G.  
 $V_{MG}$  =MAXIMUM VERTICAL MAIN GEAR GROUND LOAD AT MOST FORWARD C.G.  
 $H$ =MAXIMUM HORIZONTAL GROUND LOAD FROM BRAKING

NOTE: ALL LOADS CALCULATED USING AIRCRAFT MAXIMUM RAMP WEIGHT

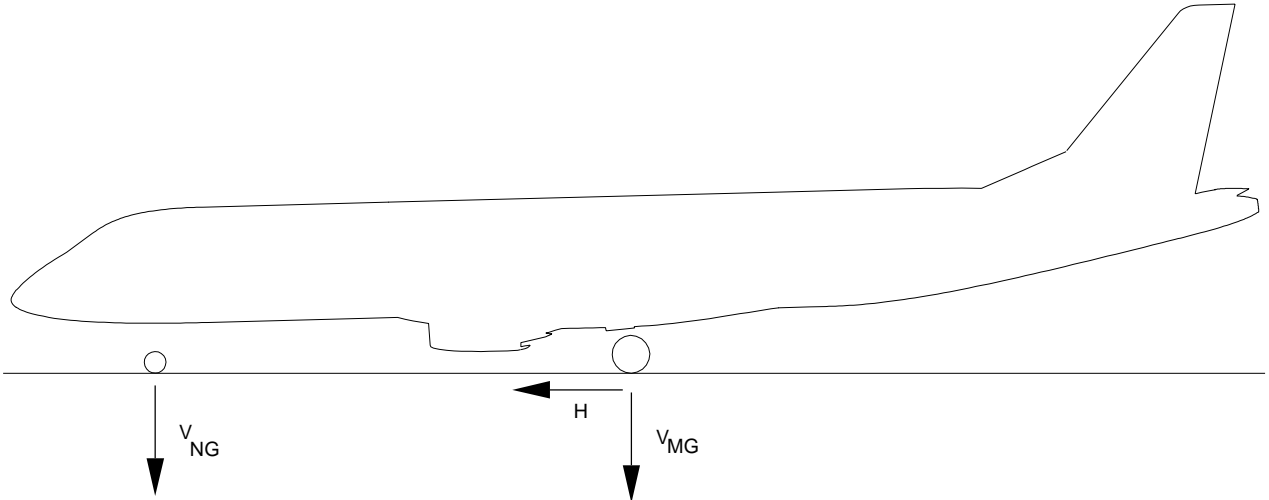

MODEL	MAXIMUM RAMP WEIGHT	$V_{NG}$		$V_{MG}$ (PER STRUT)	$H$ (PER STRUT)	
		STATIC AT MOST FORWARD C.G.	STEADY BRAKING WITH DECELERATION OF 3,0 m/sec <sup>2</sup>	STATIC AT MOST AFT C.G.	STEADY BRAKING WITH DECELERATION OF 3,0 m/sec <sup>2</sup>	INSTANTANEOUS BRAKING (FRICTION COEF. OF 0.8)
LR	50460 kg (111245 lb)	6424 kg (14162 lb)	8917 kg (19659 lb)	23301 kg (51370 lb)	6814 kg (15022 lb)	16138 kg (35578 lb)
STD	47950 kg (105712 lb)	6470 kg (14264 lb)	8820 kg (19445 lb)	22213 kg (48971 lb)	6494 kg (14317 lb)	15376 kg (33898 lb)
AR	51960 kg (114552 lb)	6347 kg (13993 lb)	8927 kg (19681 lb)	23952 kg (52805 lb)	7005 kg (15443 lb)	16593 kg (36581 lb)
SR	46150 kg (101743 lb)	6229 kg (13732 lb)	8498 kg (18735 lb)	21181 kg (46696 lb)	6255 kg (13790 lb)	14807 kg (32644 lb)

EM170APM070028D.DGN

Maximum Pavement Loads  
Figure 7.2

EFFECTIVITY: ALL



# EMBRAER 190 AIRPORT PLANNING MANUAL

## 7.4. LANDING GEAR LOADING ON PAVEMENT

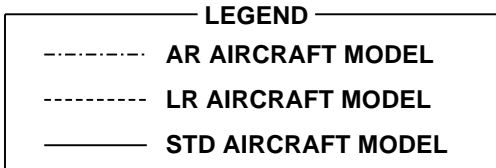
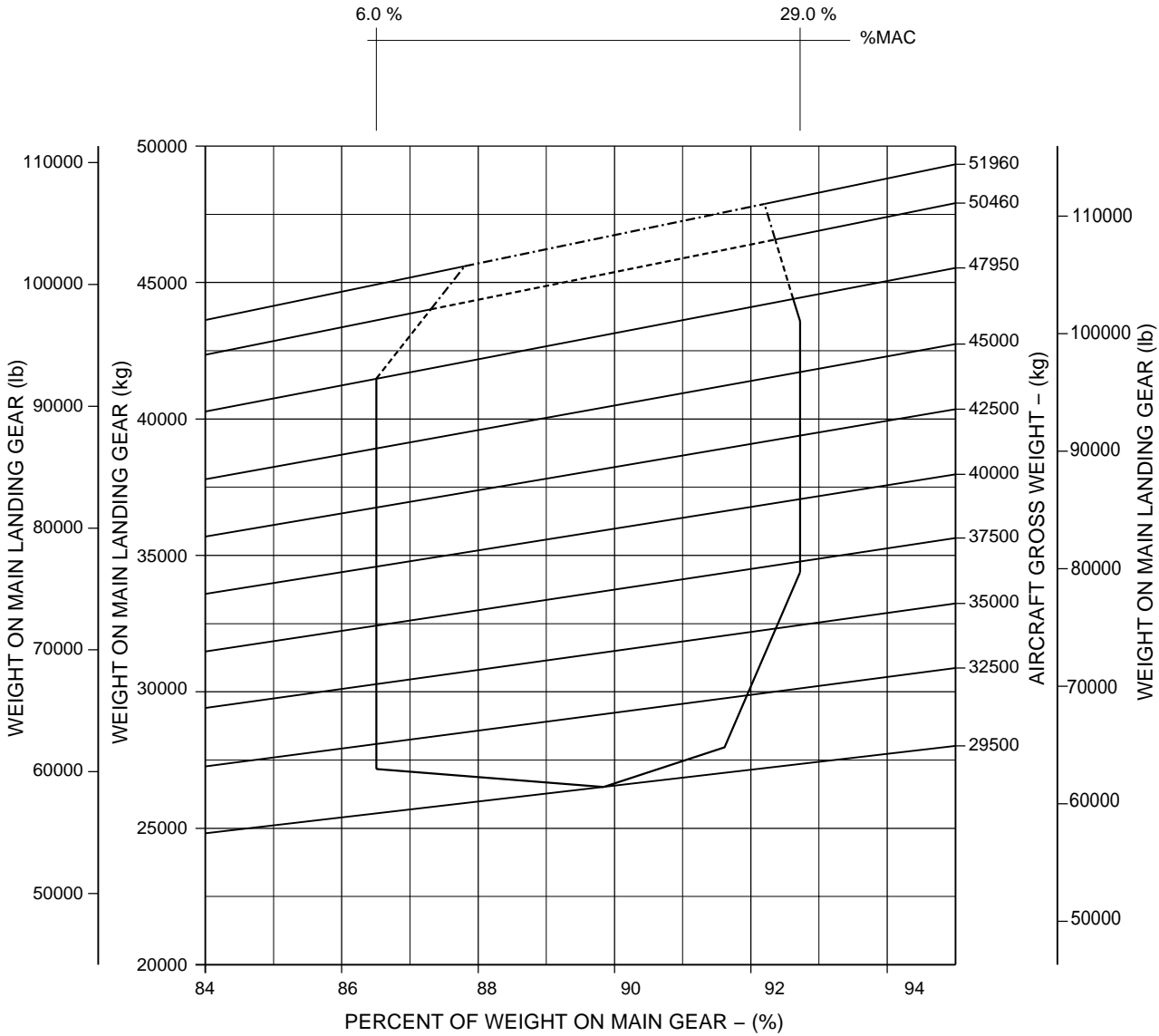

EM170APM070029B.DGN

Landing Gear Loading on Pavement  
Figure 7.3

EFFECTIVITY: ALL



# **EMBRAER 190 AIRPORT PLANNING MANUAL**

## **7.5. FLEXIBLE PAVEMENT REQUIREMENTS, US CORPS OF ENGINEERS DESIGN METHOD**

The flexible pavement curves that are based on procedures set forth in Instruction Report No. S-77-1, "Procedures for Development of CBR Design Curves", dated June 1977, and as modified according to the methods described in FAA Advisory Circular 150/5320-6D, "Airport Pavement Design and Evaluation", dated July 7, 1995. Instruction Report No. S-77-1 was prepared by the US Army Corps of Engineers Waterways Experiment Station, Soils and Pavements Laboratory, Vicksburg, Mississippi. The line showing 10,000 coverages is used to calculate ACN.



# EMBRAER 190 AIRPORT PLANNING MANUAL

## SUBGRADE STRENGTH – CBR MODEL

- NOTES:
- TIRE SIZE: H41 x 16-20 22 PR<sub>2</sub>
  - TIRE PRESSURE: 10.34 kgf/cm<sup>2</sup> (147 psi)

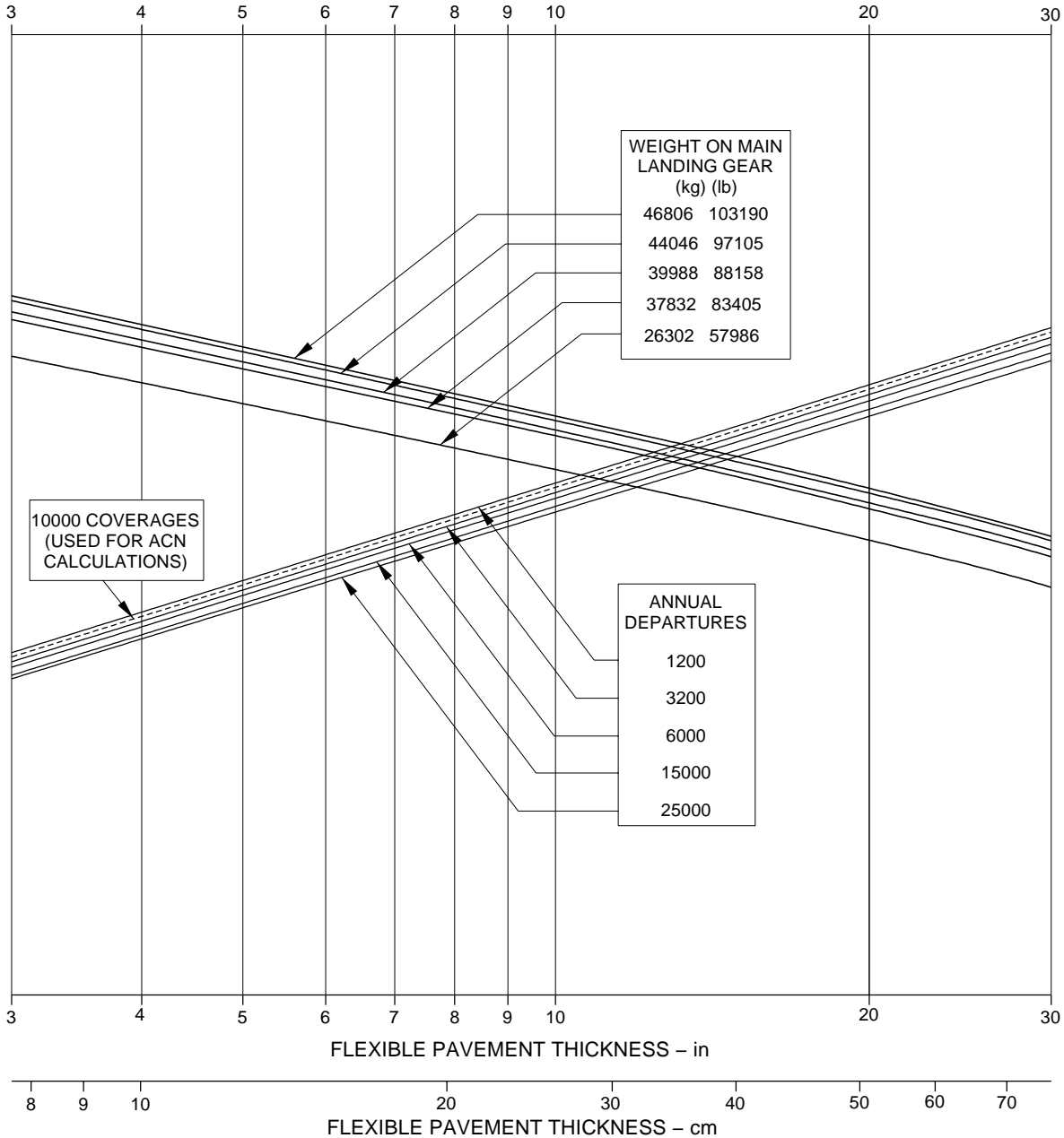
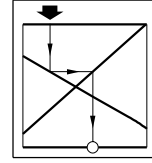

EM170APM070031A.DGN

Flexible Pavement Requirements - US Army Corps of Engineers Design Method  
Figure 7.4

EFFECTIVITY: EMBRAER 190 LR ACFT MODEL

Section 7

Page 7-6

Oct 07/13



**7.6. FLEXIBLE PAVEMENT REQUIREMENTS, LCN METHOD**

The LCN Method curves for flexible pavements. They have been built using procedures and curves in the ICAO Aerodrome Design Manual, Part 3 - Pavements, Document 9157-AN/901, 1983. The same chart includes the data of equivalent single-wheel load versus pavement thickness.



# EMBRAER 190 AIRPORT PLANNING MANUAL

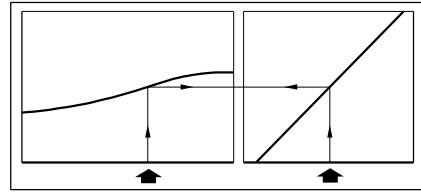

- NOTES:
- TIRE SIZE: H41x16-20 22PR<sub>2</sub>
  - TIRE PRESSURE: 10.34 kg/cm<sup>2</sup> (147 psi)

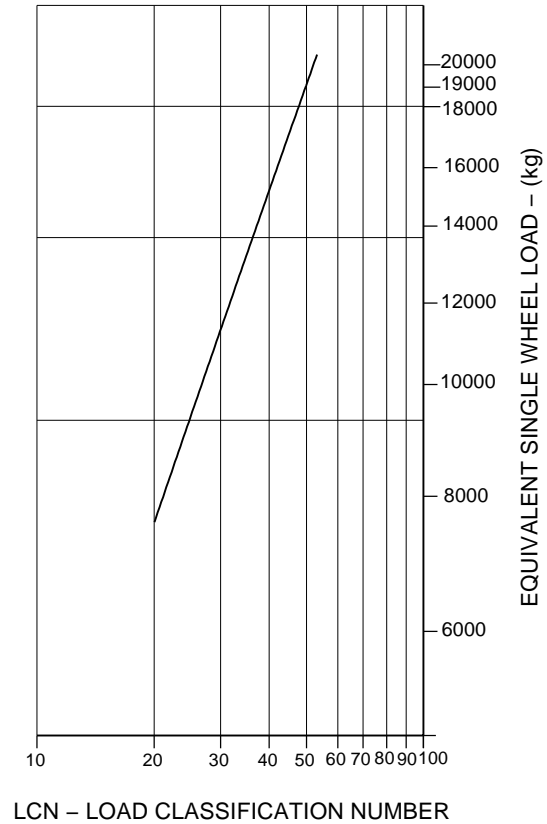
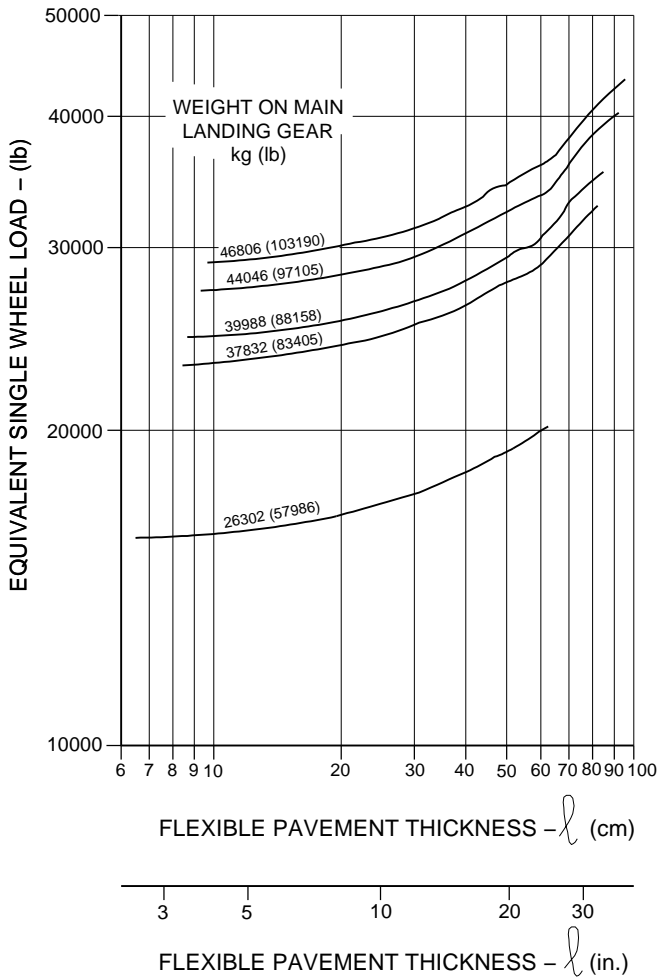

- NOTES:
- EQUIVALENT SINGLE WHEEL LOADS ARE DERIVED BY METHODS SHOWN IN ICAO AERODROME MANUAL. PART 2, PAR. 4.1.3

EM170APM070033A.DGN

Flexible Pavement Requirements - LCN Method  
Figure 7.5

EFFECTIVITY: EMBRAER 190 LR ACFT MODEL





**7.7. RIGID PAVEMENT REQUIREMENTS, PORTLAND CEMENT ASSOCIATION DESIGN METHOD**

This method has a chart that have been prepared with the use of the Westergaard Equation in general accordance with the procedures outlined in the 1955 edition of “Design of Concrete Airport Pavement” published by the Portland Cement Association, 33 W. Grand Ave., Chicago 10, Illinois, but modified to the new format described in the 1968 Portland Cement Association publication, “Computer Program for Concrete Airport Pavement Design” by Robert G. Packard. The following procedure is used to develop rigid pavement design curves such as that shown in the chart:

- Once the scale for the pavement thickness to the left and the scale for allowable working stress to the right have been established, an arbitrary load line is drawn representing the main landing gear maximum weight to be shown.
- All values of the subgrade modulus (k-values) are then plotted.
- Additional load lines for the incremental values of weight on the main landing gear are then established on the basis of the curve for  $k=300$ , already established.



# EMBRAER 190 AIRPORT PLANNING MANUAL

## RIGID PAVEMENT REQUIREMENTS

- NOTES:**
- TIRE SIZE: H41 x 16-20 22PR
  - TIRE PRESSURE: 10.34 kgf/cm<sup>2</sup> (147 psi) (UNLOADED)

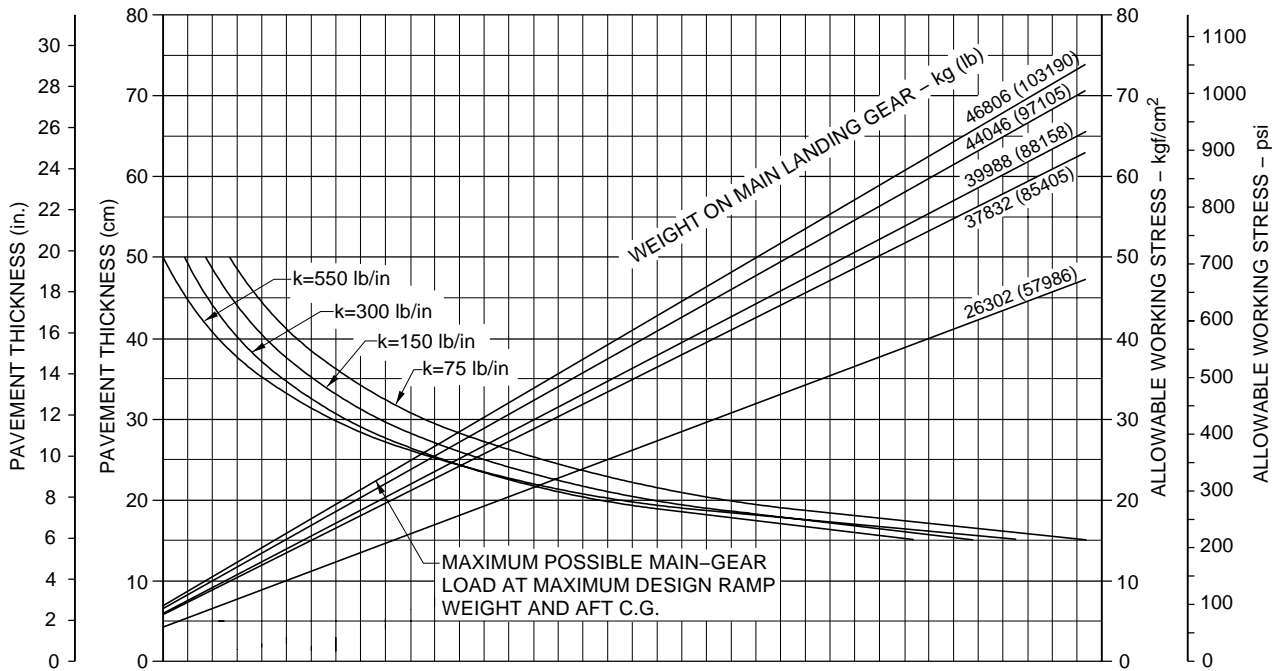
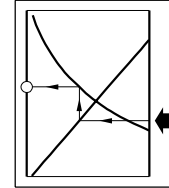

**NOTE:** THE VALUES OBTAINED BY USING THE MAXIMUM LOAD REFERENCE LINE AND ANY VALUE OF "K" ARE EXACT. FOR LOADS LESS THAN MAXIMUM, THE CURVES ARE EXACT FOR K=300 BUT DEVIATE SLIGHTLY FOR OTHER VALUES OF "K".

EM170APM070035A.DGN

Rigid Pavement Requirements - Portland Cement Association Design Method  
Figure 7.6

EFFECTIVITY: EMBRAER 190 LR ACFT MODEL



**7.8. RIGID PAVEMENT REQUIREMENTS, LCN METHOD**

This LCN Method presents curves for rigid pavements. They have been built using procedures and curves in ICAO Aerodrome Design Manual, Part 3 - Pavements, Document 9157-AN/901, 1983. The same chart includes the data of equivalent single-wheel load versus radius of relative stiffness.

To determine the aircraft weight that can be accommodated on a particular rigid airport pavement, both the LCN of the pavement and the radius of relative stiffness must be known.

The radius of relative stiffness values is obtained from a table. This table presents the radius of relative stiffness values that are based on Young's modulus (E) of 4,000,000 psi and Poisson's ratio ( $\mu$ ) of 0.15. For convenience in finding this radius based on other values of E and  $\mu$ , the curves are included. For example, to find an RRS value based on an E of 3,000,000 psi, the "E" factor of 0.931 is multiplied by the RRS value found in figure 7.6.3. The effect of the variations of  $\mu$  on the RRS value is treated in a similar manner.



# EMBRAER 190 AIRPORT PLANNING MANUAL

RADIUS OF RELATIVE STIFFNESS ( $\ell$ )  
VALUES IN INCHES

$$\ell = \sqrt[4]{\frac{Ed^3}{12(1-\mu^2)k}} = 24.1652 \sqrt[4]{\frac{d^3}{k}}$$

WHERE: E = YOUNG'S MODULUS =  $4 \times 10^6$  psi  
 k = SUBGRADE MODULUS, lb/in.<sup>3</sup>  
 d = RIGID-PAVEMENT THICKNESS, in.  
 $\mu$  = POISSON'S RATIO = 0.15

d(in)	k=75	k=100	k=150	k=200	k=250	k=300	k=350	k=400	k=500	k=550
6.0	31.48	29.30	26.47	24.63	23.30	22.26	21.42	20.72	19.59	19.13
6.5	33.43	31.11	28.11	26.16	24.74	23.64	22.74	22.00	20.80	20.31
7.0	35.34	32.89	29.72	27.65	26.15	24.99	24.04	23.25	21.99	21.47
7.5	37.22	34.63	31.29	29.12	27.54	26.32	25.32	24.49	23.16	22.61
8.0	39.06	36.35	32.85	30.57	28.91	27.62	26.58	25.70	24.31	23.74
8.5	40.88	38.04	34.37	31.99	30.25	28.91	27.81	26.90	25.44	24.84
9.0	42.67	39.71	35.88	33.39	31.58	30.17	29.03	28.08	26.55	25.93
9.5	44.43	41.35	37.36	34.77	32.89	31.42	30.23	29.24	27.65	27.00
10.0	46.18	42.97	38.83	36.14	34.17	32.65	31.42	30.39	28.74	28.06
10.5	47.90	44.57	40.28	37.48	35.45	33.87	32.59	31.52	29.81	29.11
11.0	49.60	46.16	41.71	38.81	36.71	35.07	33.75	32.64	30.87	30.14
11.5	51.28	47.72	43.12	40.13	37.95	36.26	34.89	33.74	31.91	31.16
12.0	52.94	49.27	44.52	41.43	39.18	37.44	36.02	34.84	32.95	32.17
12.5	54.59	50.80	45.90	42.72	40.40	38.60	37.14	35.92	33.97	33.17
13.0	56.22	52.32	47.27	43.99	41.61	39.75	38.25	36.99	34.99	34.16
13.5	57.83	53.82	48.63	45.26	42.80	40.89	39.35	38.06	35.99	35.14
14.0	59.43	55.31	49.98	46.51	43.98	42.02	40.44	39.11	36.99	36.12
14.5	61.02	56.78	51.31	47.75	45.16	43.15	41.51	40.15	37.97	37.08
15.0	62.59	58.25	52.63	48.98	46.32	44.26	42.58	41.19	38.95	38.03
15.5	64.15	59.70	53.94	50.20	47.47	45.36	43.64	42.21	39.92	38.98
16.0	65.69	61.13	55.24	51.41	48.62	46.45	44.70	43.23	40.88	39.92
16.5	67.23	62.56	56.53	52.61	49.75	47.54	45.74	44.24	41.84	40.85
17.0	68.75	63.98	57.81	53.80	50.88	48.61	46.77	45.24	42.78	41.78
17.5	70.26	65.38	59.08	54.98	52.00	49.68	47.80	46.23	43.72	42.70
18.0	71.76	66.78	60.34	56.15	53.11	50.74	48.82	47.22	44.66	43.61
18.5	73.25	68.17	61.60	57.32	54.21	51.80	49.84	48.20	45.59	44.51
19.0	74.73	69.54	62.84	58.48	55.31	52.84	50.84	49.17	46.51	45.41
19.5	76.20	70.91	64.08	59.63	56.39	53.88	51.84	50.14	47.42	46.30
20.0	77.66	72.27	65.30	60.77	57.47	54.91	52.84	51.10	48.33	47.19
20.5	79.11	73.62	66.52	61.91	58.55	55.94	53.83	52.06	49.23	48.07
21.0	80.55	74.96	67.74	63.04	59.62	56.96	54.81	53.01	50.13	48.95
21.5	81.99	76.30	68.94	64.16	60.68	57.97	55.78	53.95	51.02	49.82
22.0	83.41	77.63	70.14	65.28	61.73	58.98	56.75	54.89	51.91	50.69
22.5	84.83	78.95	71.34	66.38	62.78	59.99	57.72	55.82	52.79	51.55
23.0	86.24	80.26	72.52	67.49	63.83	60.98	58.68	56.75	53.67	52.41
23.5	87.64	81.56	73.70	68.59	64.86	61.97	59.63	57.67	54.54	53.26
24.0	89.04	82.86	74.87	69.68	65.90	62.96	60.58	58.59	55.41	54.11
24.5	90.43	84.15	76.04	70.76	66.92	63.94	61.52	59.50	56.28	54.95
25.0	91.81	85.44	77.20	71.84	67.95	64.92	62.46	60.41	57.14	55.79

Radius of Relative Stiffness  
Figure 7.7

EM170APM070007.DGN

EFFECTIVITY: ALL



# EMBRAER 190 AIRPORT PLANNING MANUAL

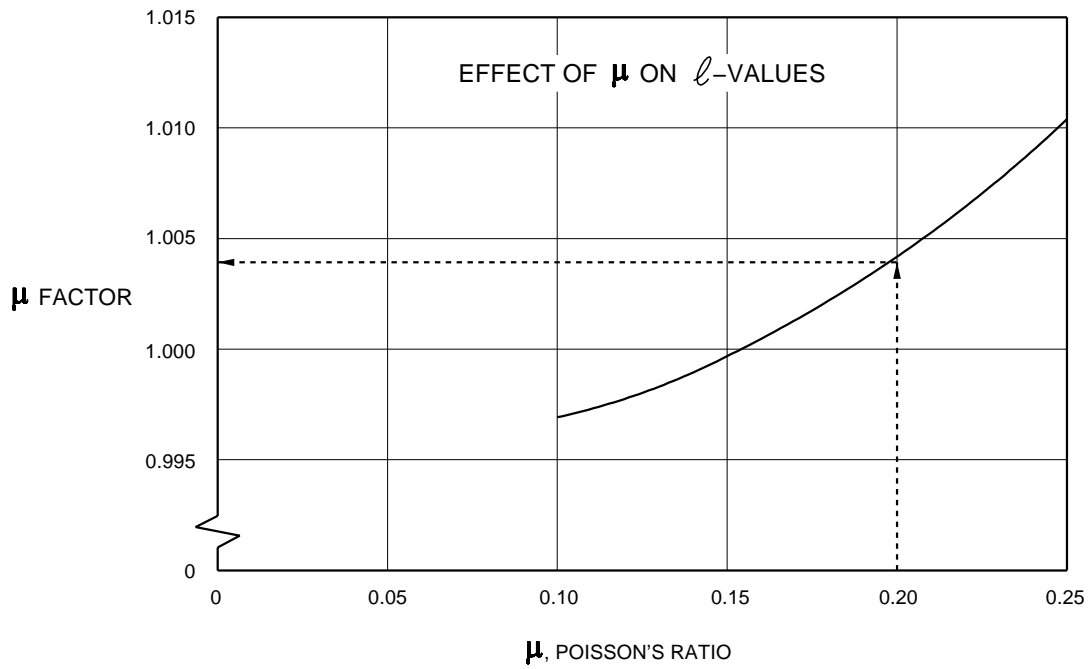
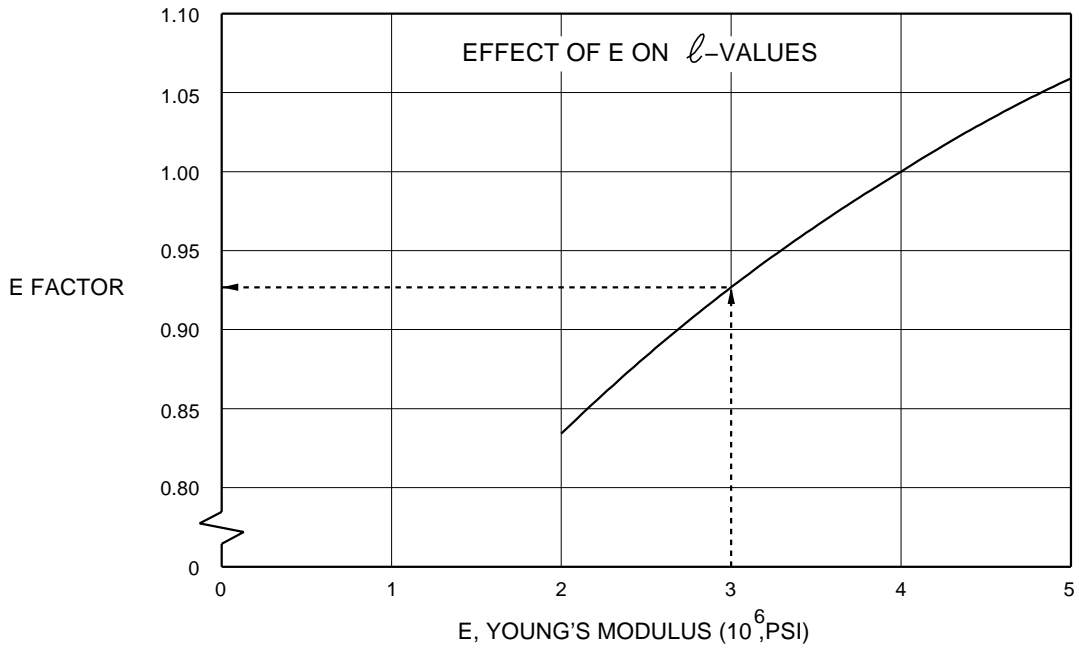

**NOTE:** BOTH CURVES ON THIS PAGE ARE USED TO ADJUST THE  $l$ -VALUES.

Radius of Relative Stiffness (other values)  
Figure 7.8

EM170APM070008.DGN

EFFECTIVITY: ALL



# EMBRAER 190 AIRPORT PLANNING MANUAL

- NOTES:
- TIRE SIZE: H41 x 16-20 22 PR<sub>2</sub>
  - TIRE PRESSURE: 10.34 kgf/cm<sup>2</sup> (147 psi)

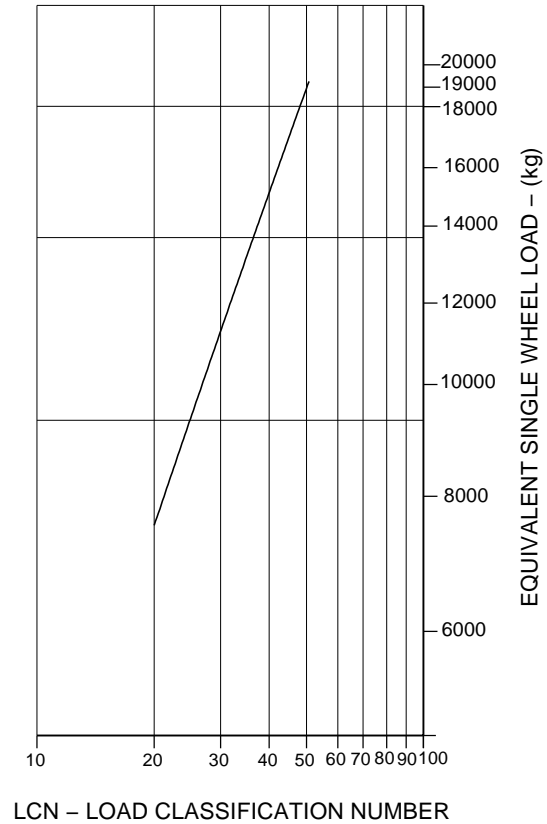
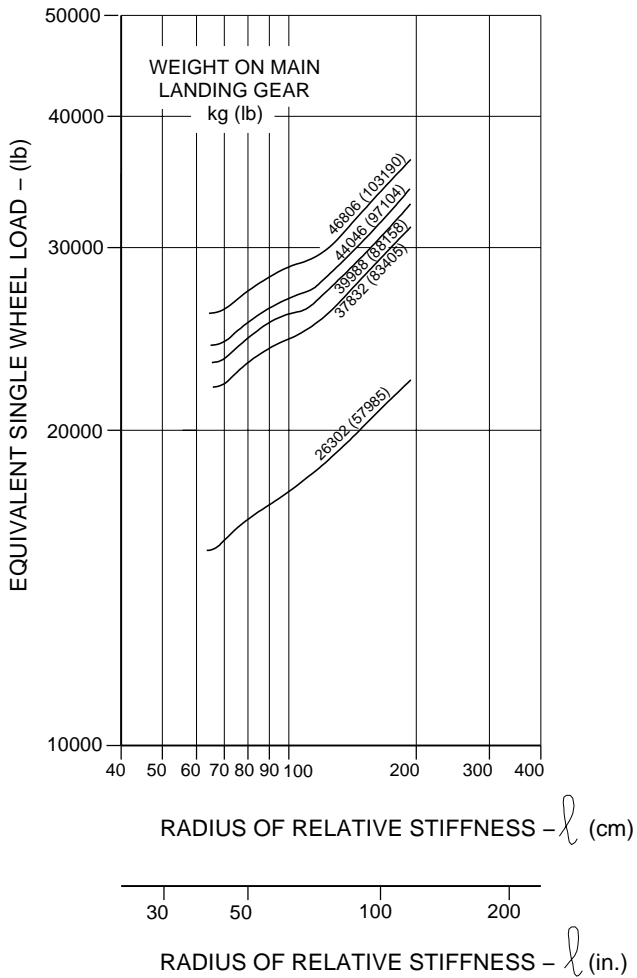
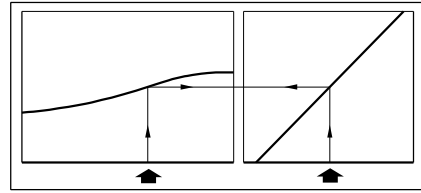

**NOTES:**  
EQUIVALENT SINGLE WHEEL LOADS ARE DERIVED BY METHODS SHOWN IN ICAO AERODROME MANUAL. PART 2, PAR. 4.1.3

EM170APM070037A.DGN

Rigid Pavement Requirements - LCN Method  
Figure 7.9

EFFECTIVITY: EMBRAER 190 LR ACFT MODEL



**7.9. ACN - PCN SYSTEM - FLEXIBLE AND RIGID PAVEMENTS**

The ACN/PCN system as referenced in Amendment 35 to ICAO Annex 14, “Aerodromes”, provides a standardized international aircraft/pavement rating system.

The PCN is an index rating of the mass which an evaluation shows can be borne by the pavement when applied by a standard single wheel. The ACN established for the particular pavement type and subgrade category of the rated pavement as well as for the particular aircraft mass and characteristics.

An aircraft shall have an ACN equal to or less than the PCN to operate without restriction on the pavement.

The method of pavement evaluation is left up to the airport with the results of their evaluation presented as follows:

Table 7.1 - Pavement Evaluation

PAVEMENT TYPE	SUBGRADE CATEGORY	TIRE PRESSURE CATEGORY	METHOD
R – Rigid	A – High	W – No Limit	T – Technical
F – Flexible	B – Medium	X – to 1.75 Mpa (254 psi)	U – Using aircraft
	C – Low	Y – to 1.25 Mpa (181 psi)	
	D – Ultra Low	Z – to 0.5 Mpa (73 psi)	
Report example: PCN 80/R/B/X/T, where: 80 = PCN R = Pavement Type: Rigid B = Subgrade Category: Medium X = Tire Pressure Category: Medium (limited to 1.5 Mpa) T = Evaluation Method: Technical			

The flexible pavements have four subgrade categories:

- A. High Strength - CBR 15.
- B. Medium Strength - CBR 10.
- C. Low Strength - CBR 6.
- D. Ultra Low Strength - CBR 3.

The rigid pavements have four subgrade categories:

- A. High Strength - Subgrade  $k = 150 \text{ MN/m}^3$  (550 lb/in<sup>3</sup>).
- B. Medium Strength -  $k = 80 \text{ MN/m}^3$  (300 lb/in<sup>3</sup>).
- C. Low Strength -  $k = 40 \text{ MN/m}^3$  (150 lb/in<sup>3</sup>).
- D. Ultra Low Strength -  $k = 20 \text{ MN/m}^3$  (75 lb/in<sup>3</sup>).



# EMBRAER 190 AIRPORT PLANNING MANUAL

## FLEXIBLE PAVEMENT SUBGRADE

- NOTES:
- TIRE SIZE: H41 x 16-20 22 PR<sub>2</sub>
  - TIRE PRESSURE: 10.34 kgf/cm<sup>2</sup> (147 psi) (UNLOADED)

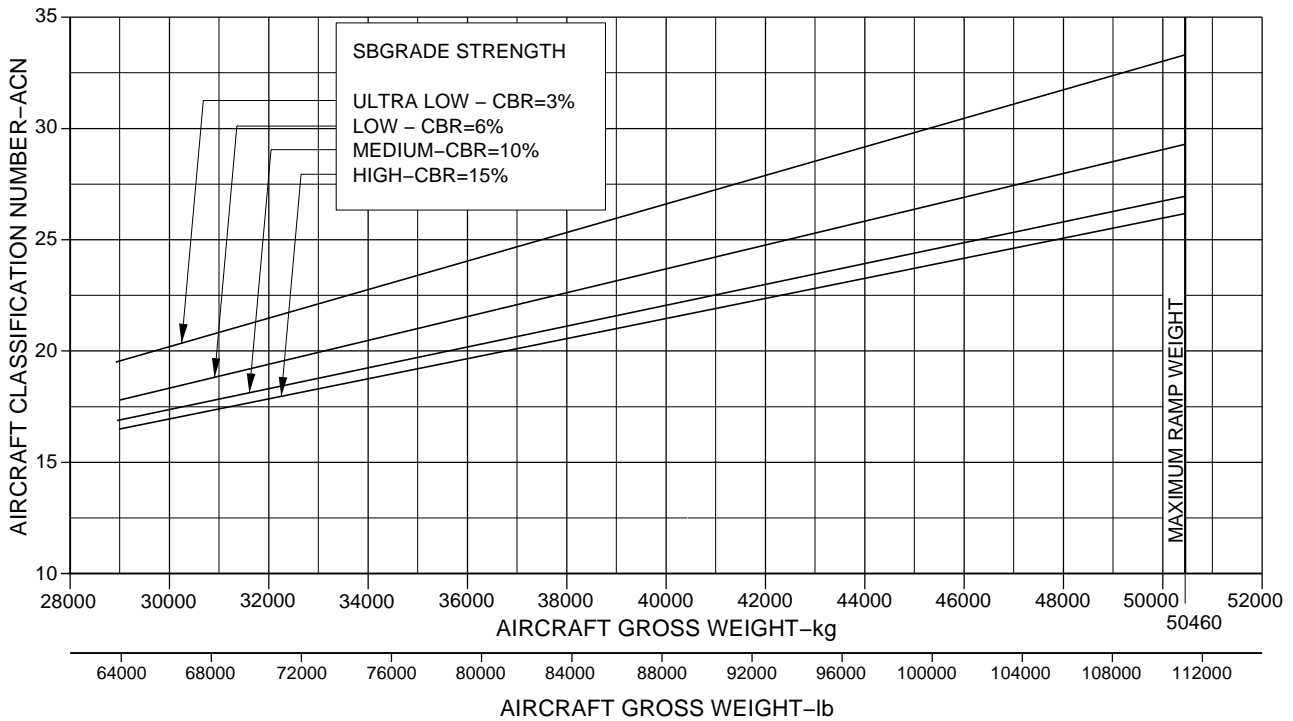
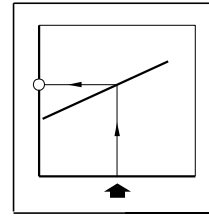

EM170APM070039A.DGN

ACN For Flexible Pavement  
Figure 7.10

EFFECTIVITY: EMBRAER 190 LR ACFT MODEL





# EMBRAER 190 AIRPORT PLANNING MANUAL

## RIGID PAVEMENT SUBGRADE

- NOTES:
- TIRE SIZE: H41 x 16-20 22 PR<sub>2</sub>
  - TIRE PRESSURE: 10.34 kgf/cm<sup>2</sup> (147 psi) (UNLOADED)

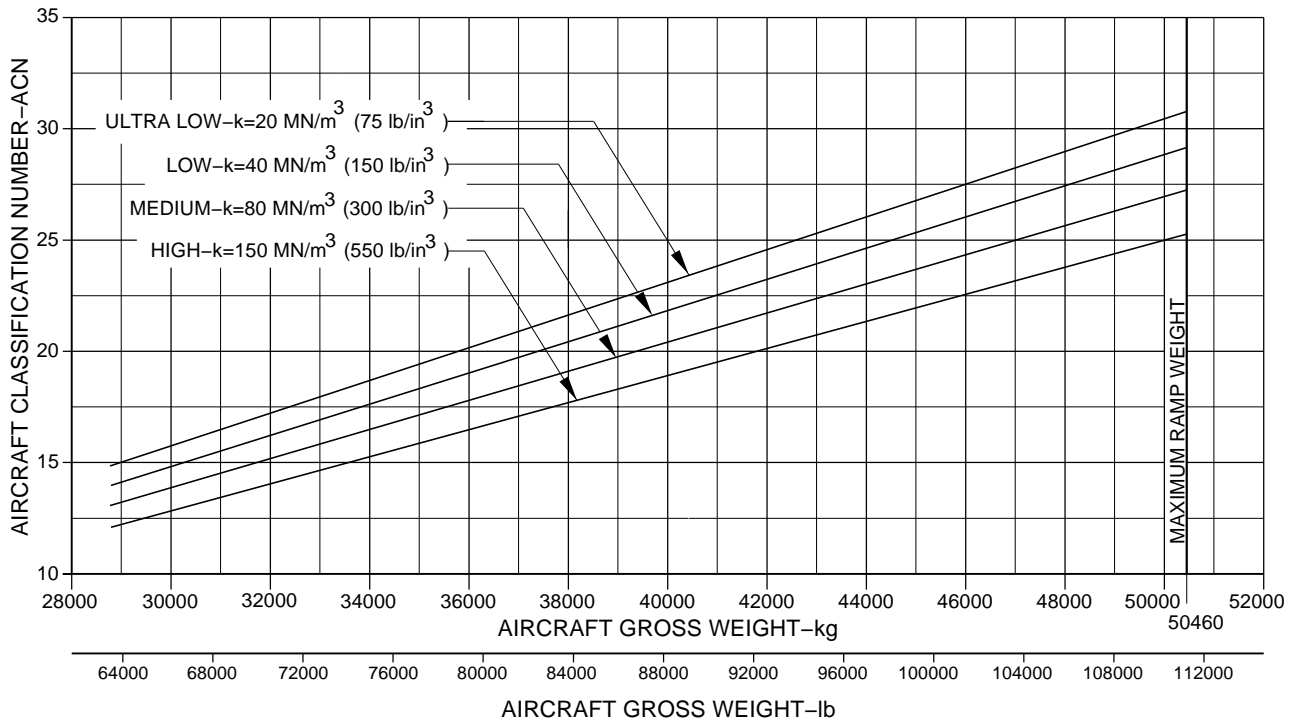
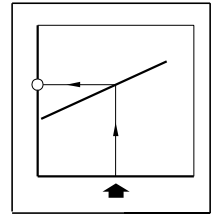

ACN For Rigid Pavement  
Figure 7.11

EFFECTIVITY: EMBRAER 190 LR ACFT MODEL





# **EMBRAER 190** AIRPORT PLANNING MANUAL

- 8. POSSIBLE EMBRAER 190 DERIVATIVE AIRCRAFT**
- 8.1. NOT APPLICABLE**

EFFECTIVITY: ALL





## **9. SCALED DRAWINGS**

### **9.1. GENERAL**

This section provides plan views to the following scales:

- English/American Customary Weights and Measures
  - 1 inch = 32 feet
  - 1 inch = 50 feet
  - 1 inch = 100 feet
- Metric
  - 1:500
  - 1:1000



# EMBRAER 190 AIRPORT PLANNING MANUAL

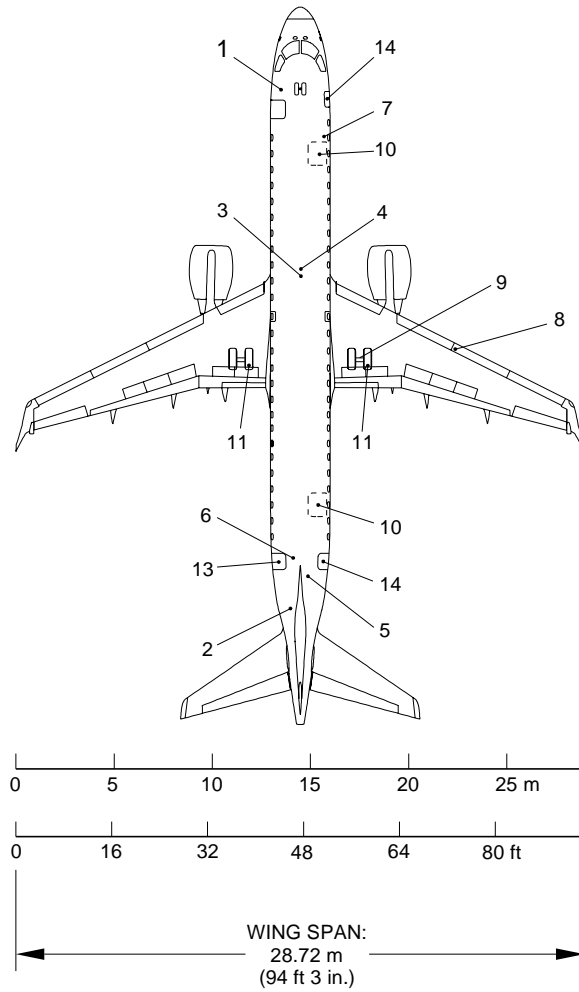

ITEM	DESCRIPTION	ITEM	DESCRIPTION
1	EXTERNAL POWER SUPPLY 115 VAC	8	PRESSURE REFUELING / DEFUELING
2	EXTERNAL POWER SUPPLY 28 VDC	9	GROUNDING POINT (RIGHT MLG)
3	ENGINE AIR STARTING	10	CARGO DOOR
4	AIR CONDITIONING LOW PRESSURE	11	MAIN LANDING GEAR
5	WASTE SERVICING PANEL	12	NOSE LANDING GEAR
6	POTABLE WATER SERVICING PANEL	13	PASSENGER DOOR
7	OXYGEN REFILL / REPLACE BOTTLE	14	SERVICE DOOR

EM170APM090006.DGN

Scale: 1 Inch Equals 32 Feet  
Figure 9.1

EFFECTIVITY: ALL



# EMBRAER 190 AIRPORT PLANNING MANUAL

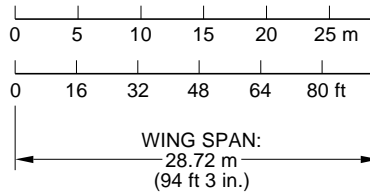
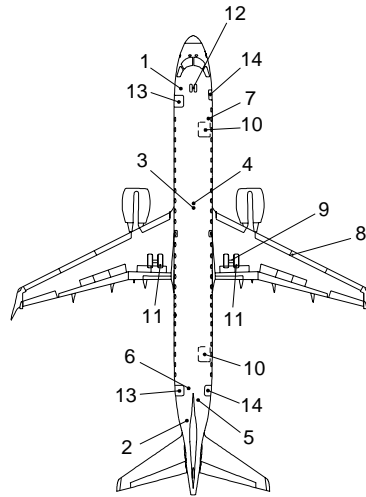

ITEM	DESCRIPTION	ITEM	DESCRIPTION
1	EXTERNAL POWER SUPPLY 115 VAC	8	PRESSURE REFUELING / DEFUELING
2	EXTERNAL POWER SUPPLY 28 VDC	9	GROUNDING POINT (RIGHT MLG)
3	ENGINE AIR STARTING	10	CARGO DOOR
4	AIR CONDITIONING LOW PRESSURE	11	MAIN LANDING GEAR
5	WASTE SERVICING PANEL	12	NOSE LANDING GEAR
6	POTABLE WATER SERVICING PANEL	13	PASSENGER DOOR
7	OXYGEN REFILL / REPLACE BOTTLE	14	SERVICE DOOR

Scale: 1 Inch Equals 50 Feet  
Figure 9.2

EM170APM090007.DGN

EFFECTIVITY: ALL



# EMBRAER 190 AIRPORT PLANNING MANUAL

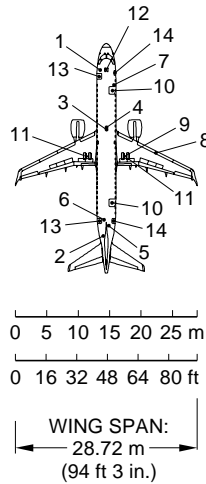

ITEM	DESCRIPTION	ITEM	DESCRIPTION
1	EXTERNAL POWER SUPPLY 115 VAC	8	PRESSURE REFUELING / DEFUELING
2	EXTERNAL POWER SUPPLY 28 VDC	9	GROUNDING POINT (RIGHT MLG)
3	ENGINE AIR STARTING	10	CARGO DOOR
4	AIR CONDITIONING LOW PRESSURE	11	MAIN LANDING GEAR
5	WASTE SERVICING PANEL	12	NOSE LANDING GEAR
6	POTABLE WATER SERVICING PANEL	13	PASSENGER DOOR
7	OXYGEN REFILL / REPLACE BOTTLE	14	SERVICE DOOR

EM170APM090008.DGN

Scale: 1 Inch Equals 100 Feet  
Figure 9.3

EFFECTIVITY: ALL

**Section 9**

Page 9-4

Oct 07/13





# EMBRAER 190 AIRPORT PLANNING MANUAL

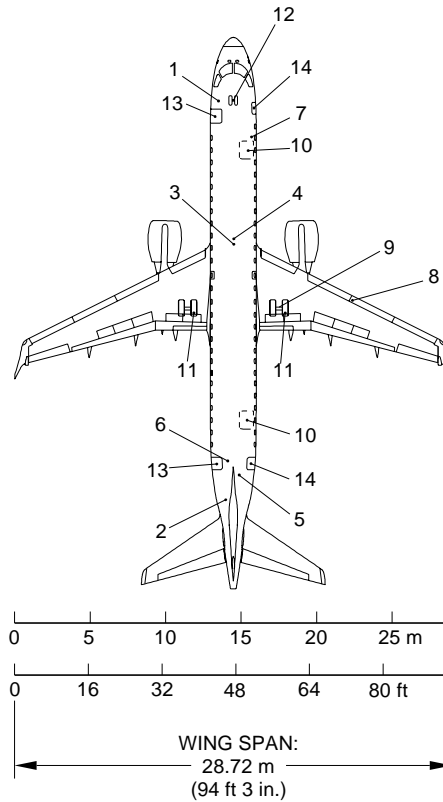

ITEM	DESCRIPTION	ITEM	DESCRIPTION
1	EXTERNAL POWER SUPPLY 115 VAC	8	PRESSURE REFUELING / DEFUELING
2	EXTERNAL POWER SUPPLY 28 VDC	9	GROUNDING POINT (RIGHT MLG)
3	ENGINE AIR STARTING	10	CARGO DOOR
4	AIR CONDITIONING LOW PRESSURE	11	MAIN LANDING GEAR
5	WASTE SERVICING PANEL	12	NOSE LANDING GEAR
6	POTABLE WATER SERVICING PANEL	13	PASSENGER DOOR
7	OXYGEN REFILL / REPLACE BOTTLE	14	SERVICE DOOR

EM170APM090009.DGN

Scale: 1 to 500  
Figure 9.4

EFFECTIVITY: ALL



# EMBRAER 190 AIRPORT PLANNING MANUAL

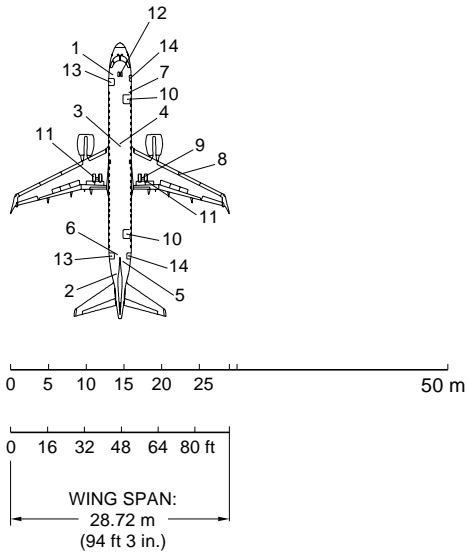

ITEM	DESCRIPTION	ITEM	DESCRIPTION
1	EXTERNAL POWER SUPPLY 115 VAC	8	PRESSURE REFUELING / DEFUELING
2	EXTERNAL POWER SUPPLY 28 VDC	9	GROUNDING POINT (RIGHT MLG)
3	ENGINE AIR STARTING	10	CARGO DOOR
4	AIR CONDITIONING LOW PRESSURE	11	MAIN LANDING GEAR
5	WASTE SERVICING PANEL	12	NOSE LANDING GEAR
6	POTABLE WATER SERVICING PANEL	13	PASSENGER DOOR
7	OXYGEN REFILL / REPLACE BOTTLE	14	SERVICE DOOR

EM170APM090010.DGN

Scale: 1 to 1000  
Figure 9.5

EFFECTIVITY: ALL