

EMB120 **Brasilia**

STANDARD OPERATING PROCEDURES MANUAL

EMPRESA BRASILEIRA DE AERONÁUTICA S.A.

THIS MANUAL IS APPLICABLE TO ALL EMB-120.

SOP – 120/1624

MAY 31, 2002



CUSTOMER COMMENT FORM

Standard Operating Procedures Manual SOP – 120/1624

Please use this Customer Comment Form to notify us of any discrepancies or problems you find in the Standard Operating Procedures. We would also welcome constructive suggestions on how we can further improve our documentation or service.

Your feedback will be acknowledged, and we will advise you of the action we intend to take.

Sincerely,
Embraer Operations Support

Please return this form to:

Embraer - DST/GSO/SEO - PC176
Av. Brigadeiro Faria Lima, 2170
CEP 12227-901
São José dos Campos - SP - BRASIL
P.O. Box 8050

Phone: +55 12 3927-1706
Fax: +55 12 3927-2477
E-mail: opereng@embraer.com.br



LIST OF EFFECTIVE PAGES

ORIGINAL0 MAY 31, 2002

Title	ORIGINAL	3-8	ORIGINAL
A	ORIGINAL	4-1	ORIGINAL
B	ORIGINAL	4-2	ORIGINAL
		4-3	ORIGINAL
i	ORIGINAL	4-4	ORIGINAL
ii	ORIGINAL	4-5	ORIGINAL
		4-6	ORIGINAL
1-1	ORIGINAL	4-7	ORIGINAL
1-2	ORIGINAL	4-8	ORIGINAL
1-3	ORIGINAL	4-9	ORIGINAL
1-4	ORIGINAL	4-10	ORIGINAL
		4-11	ORIGINAL
		4-12	ORIGINAL
2-1	ORIGINAL		
2-2	ORIGINAL		
2-3	ORIGINAL	5-1	ORIGINAL
2-4	ORIGINAL	5-2	ORIGINAL
2-5	ORIGINAL	5-3	ORIGINAL
2-6	ORIGINAL	5-4	ORIGINAL
		5-5	ORIGINAL
3-1	ORIGINAL	5-6	ORIGINAL
3-2	ORIGINAL	5-7	ORIGINAL
3-3	ORIGINAL	5-8	ORIGINAL
3-4	ORIGINAL	5-9	ORIGINAL
3-5	ORIGINAL	5-10	ORIGINAL
3-6	ORIGINAL	5-11	ORIGINAL
3-7	ORIGINAL	5-12	ORIGINAL

* Asterisk indicates pages revised, added or deleted by the current revision.



5-13	ORIGINAL	5-53	ORIGINAL
5-14	ORIGINAL	5-54	ORIGINAL
5-15	ORIGINAL	5-55	ORIGINAL
5-16	ORIGINAL	5-56	ORIGINAL
5-17	ORIGINAL	5-57	ORIGINAL
5-18	ORIGINAL	5-58	ORIGINAL
5-19	ORIGINAL	5-59	ORIGINAL
5-20	ORIGINAL	5-60	ORIGINAL
5-21	ORIGINAL	5-61	ORIGINAL
5-22	ORIGINAL	5-62	ORIGINAL
5-23	ORIGINAL	5-63	ORIGINAL
5-24	ORIGINAL	5-64	ORIGINAL
5-25	ORIGINAL	5-65	ORIGINAL
5-26	ORIGINAL	5-66	ORIGINAL
5-27	ORIGINAL	5-67	ORIGINAL
5-28	ORIGINAL	5-68	ORIGINAL
5-29	ORIGINAL	5-69	ORIGINAL
5-30	ORIGINAL	5-70	ORIGINAL
5-31	ORIGINAL	5-71	ORIGINAL
5-32	ORIGINAL	5-72	ORIGINAL
5-33	ORIGINAL		
5-34	ORIGINAL	6-1	ORIGINAL
5-35	ORIGINAL	6-2	ORIGINAL
5-36	ORIGINAL	6-3	ORIGINAL
5-37	ORIGINAL	6-4	ORIGINAL
5-38	ORIGINAL	6-5	ORIGINAL
5-39	ORIGINAL	6-6	ORIGINAL
5-40	ORIGINAL	6-7	ORIGINAL
5-41	ORIGINAL	6-8	ORIGINAL
5-42	ORIGINAL	6-9	ORIGINAL
5-43	ORIGINAL	6-10	ORIGINAL
5-44	ORIGINAL	6-11	ORIGINAL
5-45	ORIGINAL	6-12	ORIGINAL
5-46	ORIGINAL		
5-47	ORIGINAL		
5-48	ORIGINAL		
5-49	ORIGINAL		
5-50	ORIGINAL		
5-51	ORIGINAL		
5-52	ORIGINAL		

* Asterisk indicates pages revised, added or deleted by the current revision.

MAY 31, 2002



TABLE OF CONTENTS

Introduction	1-1
Basic Definitions.....	2-1
Philosophy of Operation.....	3-1
Operating Policies	4-1
Normal Procedures	5-1
Patterns and Techniques	6-1



THIS PAGE IS LEFT BLANK INTENTIONALLY



SECTION 1

INTRODUCTION

General	1-3
The On Board Checklist Concept	1-4



THIS PAGE IS LEFT BLANK INTENTIONALLY



INTRODUCTION

GENERAL

The purpose of this manual is to serve as a guideline for the implementation of safe and efficient operation procedures for EMB-120 airplane.

The use of this manual is optional. It is not a replacement for any of the operational manuals required by applicable regulations such as the Airplane Flight Manual or the Company Operations Manual.

The underlying philosophy behind the operating framework of this Manual is based on reducing as much as possible the operational shortcomings related to human factors, namely:

- Improper coordination among flight crewmembers
- Improper coordination between flight and cabin crewmembers
- Distraction from basic flying tasks
- Misunderstandings
- Perplexity
- Tunneling
- Obsession

The Philosophy of Operation Section has directives that are principles relating to how the operation should be conducted in its broadest sense. Topics like Task Delegation, Teamwork principles and Prerogatives of a Copilot are included therein.

The Operating Policies Section has operating guidelines that are not procedures to be followed. They are rather rules to be observed should a specific situation arise regardless of when and where it occurs during the flight. Topics such as handling of the autopilot and task sharing when hand flying the aircraft are covered there.

The Normal Procedures Section basically presents the AFM Normal Procedures in a far more detailed manner. The intention is to eliminate any doubts regarding Flight Standards that may arise during the operation of the aircraft or during simulator sessions.



This SOP is optimized for passenger-carrying operation in a regional airline environment. It assumes that the cabin crew is on board and that there are passengers.

Each procedure phase is started presenting a proposed checklist followed by a thorough explanation of the procedures for that phase.

The checklist is supposed to be routinely used on board and its conception was based on the following principles:

THE ON BOARD CHECK LIST CONCEPT

The use of the on board check list is based on the assumption that both pilots have been properly trained on the type of aircraft and therefore have a thorough knowledge of the airplane's systems and procedures. It further assumes that they know the consequences of their actions (or the consequences of not performing the right actions at the right time).

The on board check list is just a memory aid to assist the pilots so they do not forget actions which, if not carried out, can in one way or another result in some type of risk to the aircraft, to the operational environment, to any of its systems, to its occupants or to the passengers comfort.

The procedures to be carried out in each phase are not restricted to the checklist. These procedures are explained in detail after each phase checklist and are consistent with the procedures set forth in the AFM.

Should any discrepancy between the SOP and the AFM be detected, the AFM prevails.



SECTION 2

BASIC DEFINITIONS

Introduction	2-3
Definitions	2-3



THIS PAGE IS LEFT BLANK INTENTIONALLY



BASIC DEFINITIONS

INTRODUCTION

The Definitions herein exist for the sole purpose of making the text in this Manual unequivocal and clear. They do not replace or invalidate any Operating Rules in force. Should there be differences between these Definitions and the Regulations, the Regulations must prevail.

DEFINITIONS

AREAS OF RESPONSIBILITY

Cockpit panel and console areas that are operated by a specific pilot. These areas exist for the sake of crew coordination and a pilot must always advise the other pilot if he is intending to operate something in the other pilot's Area of Responsibility. Refer to the Operating Policies Section to determine what areas are assigned to which pilot.

CABIN CREW

Crewmembers that handle all the occupants of the aircraft, with the exception of other crewmembers, during a flight operation. The cabin crew is composed of Cabin Attendants.

CHALLENGE AND RESPONSE

A Check List usage technique that consists of completing all the check list actions by memory and verifying them item by item afterwards by reading and replying.

CHIEF CABIN ATTENDANT

Crewmember that reports to the Pilot-in-Command and is in charge of assuring the safety of the occupants that are not crewmembers in all circumstances. The Chief Cabin Attendant is responsible for coordinating with other cabin attendants the efficient handling of non-crewmember occupants.

COPILOT

Pilot that is not in command but can carry out the duty of flying the aircraft under circumstances established by company rules.



FLIGHT CREW

Crewmembers that conduct the airplane's flight operation.

FLIGHT OPERATION

An operation whose intention is to fly the aircraft.

IN FLIGHT ABNORMALITY

A situation that, if not handled with the appropriate procedures, may develop into an imminent flight safety risk.

IN FLIGHT EMERGENCY

A situation where there is an imminent flight safety risk.

INSTRUCTOR PILOT

Pilot that acts both as Safety Pilot and as Flight Instructor to a not-yet-qualified pilot or to a qualified pilot undergoing flight instruction for refreshment or for any other reason.

LOFT (LINE ORIENTED FLIGHT TRAINING)

Simulator training session where the focus is on reproducing an environment as similar as possible to the airline operating environment with similar workload, including all chores that are part of the normal revenue routine. The objective of these sessions is to identify areas of difficulty related to crew coordination and ergonomics. LOFT sessions may include abnormal and emergency situations that require rule-based action or knowledge-based action by the crew.

MEMORY ITEMS

Items of the Check List that must be memorized by the Flight Crew and whose execution must be carried out immediately should the corresponding Check List become applicable.

PILOT-IN-COMMAND

Pilot legally responsible for the operation of the aircraft and who commands the operation of the aircraft. He has the power to take action, to request action by the other pilot or to prevent the other pilot from acting as he finds appropriate for the sake of flight safety.



READ AND DO

A Check List usage technique that consists of reading and accomplishing each of the check list items.

REFERENCE TO CREWMEMBERS

CPT : Pilot-in-command
F/O : Copilot
C/F : Refers to both pilots in general
PF : Flying Pilot
PNF : Non-Flying Pilot
F/A : Any Cabin Attendant in general
CCA : Chief Cabin Attendant

SAFETY PILOT

The pilot in charge of ensuring that no flight operational situation ever develops that places flight safety at risk.

STERILE COCKPIT

The principle of restricting cockpit and cockpit/cabin talk strictly to what is required for the Flight Operation and for the safety of the occupants.



THIS PAGE IS LEFT BLANK INTENTIONALLY



SECTION 3

PHILOSOPHY OF OPERATION

Company Rules.....	3-3
Authority	3-3
Coordination and Relationship	3-4
Training	3-6
Law and Security.....	3-8



THIS PAGE IS LEFT BLANK INTENTIONALLY



PHILOSOPHY OF OPERATION

COMPANY RULES

COMPLIANCE WITH OPERATING DIRECTIVES

Crewmembers must abide by the operating rules and directives that are in force. Not being in agreement does not entitle any Crewmember to disobey or deviate from them.

However crewmembers can depart from them if flight or passenger safety is negatively affected by their compliance.

Rules and directives can not be disregarded in the name of the friendliness to passengers or to anybody. So as an example any Official Rule or Company Rule regarding admission of passengers to the cockpit must be strictly followed.

AUTHORITY

AUTHORITY MUST BE BEYOND DOUBT

If this Manual is not clear about who does what or who has the authority to act in any situation that may arise during Flight Operation, then the Manual must be revised so that this omission is eliminated.

AUTHORITY OF THE PILOT-IN-COMMAND

He is always the Safety Pilot. He is ultimately responsible for whatever happens to the occupants, to the aircraft or to any goods or persons outside the aircraft as result of the flight operation under his command.

The Pilot-in-Command must use crew resources in the most effective way and must encourage the other crewmembers to engage in teamwork by allowing them to participate and give suggestions whenever useful for the execution of the flight.

He must treat all crewmembers with respect and consideration at all times.

COPILOT RIGHTS AND DUTIES

The Copilot can be designated as PF for any flight leg if the Pilot-in-Command finds it appropriate.



The Copilot can and should immediately advise the Pilot-in-Command of any operational discrepancy that may develop into a flight safety problem. This entitlement to intervene must be practiced extensively in the Simulator so that the Copilots understand how and to what extent this intervention is to be exercised. Should the Pilot-in-command become incapacitated, the Copilot acquires all the rights and duties of the Pilot-in-Command.

COORDINATION AND RELATIONSHIP

FLIGHT CREW COORDINATION WITH CABIN CREW

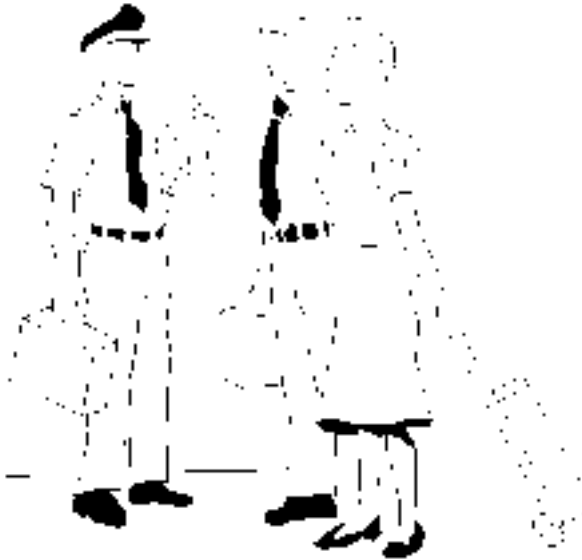

EMB120-1624

**MORE THAN A COURTESY, BRIEFING OTHER CREWMEMBERS
IS INSTRUMENTAL TO EFFICIENT TEAMWORK**



The Flight Crew must be trained on coordination with the Cabin Crew. Cabin Crewmembers must understand situations such as sterile cockpit, calls from the cockpit, pilot incapacitation and other specific in-flight situations where the participation of the Cabin Crew is instrumental. It is recommended that joint training sessions be carried out to practice this coordination. These joint training sessions can be LOFT sessions.

INTERPERSONAL RELATIONSHIP

Crewmembers should never be rude or harsh to anybody when on duty unless there is an undeniable practical reason to act in such a way for the sake of the passengers or for reasons of flight safety of since bad temper and intimidation undermine the teamwork motivation.

EMPHASIS ON COMMUNICATION WITH CABIN CREW

All members of the crew have the right to be informed regarding matters that affect their functions. Therefore preflight briefings with the Cabin Crew are highly recommended, as are inflight briefings when special non-routine procedures are to be carried out. Examples are: briefing for a landing that may possibly end up with an evacuation, or when an intermediate stop is to be prolonged for maintenance reasons, or when turbulent weather is expected enroute, etc.



TRAINING

EMPHASIS ON SITUATION AWARENESS

Pilots must undergo extensive simulator training to efficiently manage their workload and prioritize flying the aircraft. Critical high workload situations must be simulated to make sure that the pilots are capable of avoiding distraction from the basic tasks.

If the pilot is faced with too many things to be managed single-handedly, he must be trained to delegate and seek help as necessary.

TRAINING OF COPILOTS

Copilots must be trained to be fully proficient in all maneuvers and actions that they are entitled to carry out. As an example they must be fully capable of continuing a takeoff with an engine failure after V1 carrying out all procedures that are required.

Therefore, it is a Company obligation to make sure that this level of proficiency is reached. If there are facts that indicate that the required proficiency is absent, a training review process must be started by the Company to develop changes to correct this deficiency.

TAKING PROCEDURES SERIOUSLY

It is recommended that all Flight Crewmembers develop the habit of pointing at or looking at an item that is being mentioned in the Check List as they read it . This technique helps to prevent the loss of attention due to absent-minded, mechanical reading of procedures. Flight Crewmembers reading a check list must also make sure that the other pilot heard and is aware of each read item. Should any doubt persist, the item must be called out again until it is clear that it was grasped.

Full knowledge of the Memory Items is mandatory. A Flight Crewmember unable to recall Memory Items of the Check List can not be considered proficient.

CLOSELY MONITORING OPERATIONAL PERFORMANCE

All effort must be made to encourage crewmembers to report any difficulty that is related to human factors. This is fundamental to spot potential Flight Standard deficiencies before they result in incidents or accidents. Granting confidentiality and negotiating participation of pilot



unions and associations in this process are techniques that may be used to boost the importance of these reports.

Using difficulty reports to correct and improve the Flight Standards is an important process of assuring the quality of the Flight Operation.

Operational difficulties related to Human Factors observed during simulator sessions, during enroute supervision or anytime during normal operation must be collected and a review board of assigned pilots should periodically examine these reports. When the occurrence of a difficulty in statistically significant numbers is detected, this board must suggest changes in the training procedures or in the operating procedures to prevent this difficulty from happening.

If it becomes evident that crewmember or a group of them needs additional training he or they must be immediately removed from flight duty.

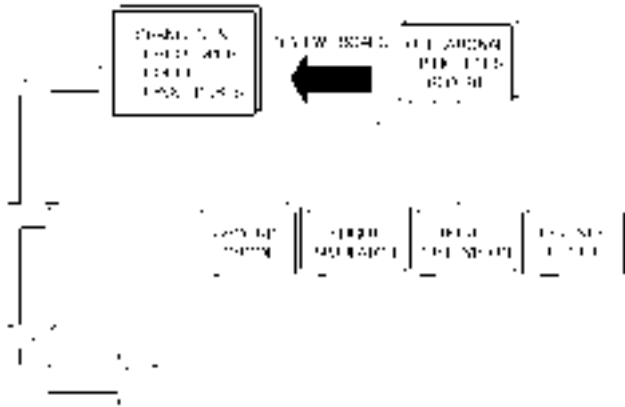

FIG. 10.10.1

OPERATIONAL QUALITY ASSURANCE PROCESS



LAW AND SECURITY

LEGAL COVERAGE

The Company must provide information regarding legal responsibilities of the crewmembers, especially that of the pilot-in-command, when it comes to liabilities resulting from legal violations, incidents and accidents. The crewmembers must be informed about the legal implications of their acts and statements as well as how to proceed in case of abnormal situations such as in case of incidents and accidents as well as in situations involving law enforcement authorities.

The information made available to crewmembers is especially important in case of flights to countries other than the country the company is located in.

Should a legal dispute arise as a consequence of the operation of a company aircraft, the company must take all measures to make sure that the crewmembers are not unfairly or improperly charged and do not suffer negative consequences that are unduly or unfairly imposed upon them.

This company attitude is important to encourage flight crew to act in a rightful rather than in a "trouble-avoiding" manner.

SECURITY ISSUES

The flight and the cabin crew members must be trained to handle unruly passengers or passengers demonstrating offensive or anti social behavior. Additionally, they must be trained to know when special passengers such as deportees and criminals can be accepted on board and on how to proceed in such cases (when to board, request for law enforcement escort, etc.).



SECTION 4

OPERATING POLICIES

Task Sharing	4-3
Description of the Areas of Responsibility	4-6
Automation	4-7
Approach and Landing	4-9
Miscellaneous Items	4-11



THIS PAGE IS LEFT BLANK INTENTIONALLY



OPERATING POLICIES

TASK SHARING

The PF/PNF task sharing concept applies from start of takeoff to after landing only.

On ground procedures are shared between the Captain and the Copilot as per the pertinent procedures in this Manual.

The copilot is responsible for reading the checklist and the captain in answering.

In flight :

The PF is in charge of:

- Throttles;
- Controlling flight path and speed;
- Carrying out the required actions at his areas of responsibility (normal, abnormal and emergency procedures);
- Aircraft configuration;
- Navigation;
- Annunciating the mode of operation displayed in the FMA (Flight Mode Annunciator) on the PFD.

The PNF is in charge of:

- Check List reading;
- Carrying out the required actions at his areas of responsibility (normal, abnormal and emergency procedures);
- Engine Shut down (Coordinated with the PF);
- ATC communications;
- Monitoring the flight and alerting the PF for any abnormal condition ;
- Call outs.

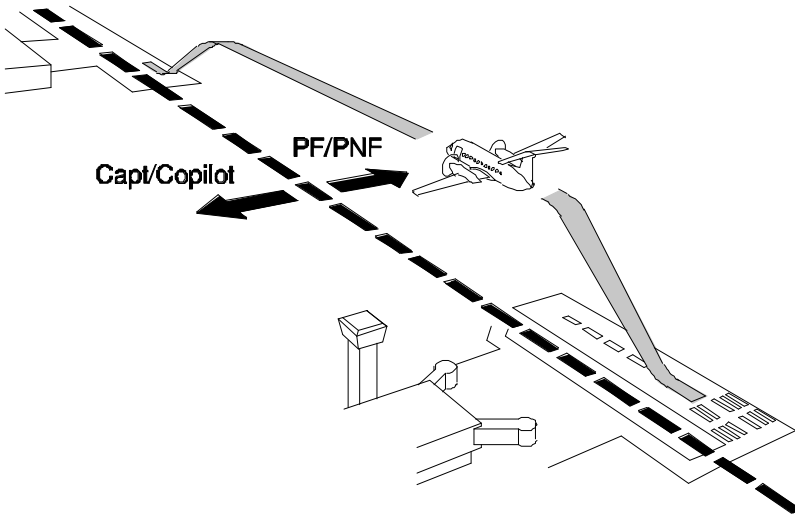

120CM080012.MCE

TASK SHARING

If the airplane is being hand-flown, then such actions as selecting heading or course, preselecting altitude, switching to another FD mode or changing the configuration of the aircraft must be asked for by the PF and executed by the PNF and any system management action such as flipping switches or turning knobs desired by the PF must be asked for by him and acted upon by the PNF.

If the aircraft is on a coupled flight (autopilot engaged) then such actions as selecting heading or course, preselecting altitude or switching to another FD mode is carried out by the PF. Changing the configuration of the aircraft must still be asked for by the PF and executed by the PNF, while system management can be carried out by the PF provided that it does not distract him from the task of monitoring flight path, speed, angle of attack and attitude.

The PNF must also check the limit speeds for configuration change before complying with any request from the PF.



NOTE: Any communication with cabin crew or with the passengers is a prerogative of the Pilot-in-Command. He may however delegate this task to the Copilot if he finds it appropriate.

All the normal procedures are to be carried out using the Challenge and Respond technique. The actions in this case are carried out according to the procedures check list; the inflight reading of the items is done by the PNF while the on ground reading is done by the F/O. The pilot that responds is specified to the right of the check list item.

All Abnormal and Emergency Procedures other than the Memory Items are to be carried out using the Read and Do technique.

The Copilot is entitled to carry out the following flight maneuvers:

- Instrument approaches, coupled or not, down to CAT I minima;
- Circle to Land maneuvers on right hand circuits;
- Profile Descents and STARS;
- SIDS;
- Visual departures and arrivals;
- Takeoff with engine failure after takeoff; Contingency Departures;
- Emergency Descent;
- Engine Out en route flight;
- Engine Out approach and landing.

The Copilot is not entitled to abort a takeoff nor is he entitled to take any action that can make an abort unavoidable.

The Copilot is not entitled to decide about what is to be communicated to the passengers unless specifically authorized by the Pilot-in-Command.



DESCRIPTION OF THE AREAS OF RESPONSIBILITY

A brief description of the Areas of Responsibility in the cockpit is necessary. Refer to the definition of Areas of Responsibility in the Basic Definitions Section for more details.

The flow below must be used during the Internal Safety inspection and the Before Start phase.

The numbers, letters and arrows show the recommended flow sequence.

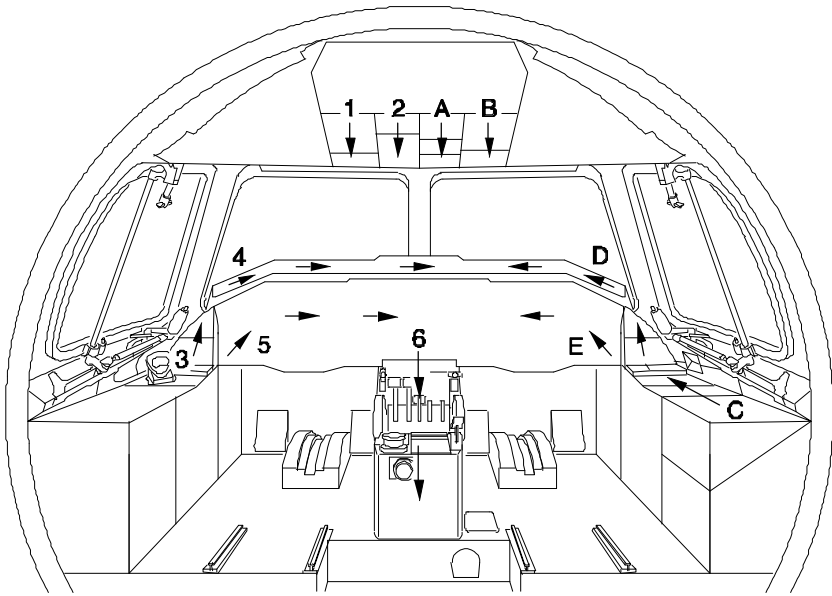

1200M060011.MCE

RECOMMENDED FLOW SEQUENCE

The numbers and arrows show the recommended flow sequence. The CPT must follow the numbers, and the F/O must follow the letters.



AUTOMATION

FLIGHT DIRECTOR

Either is consistent with what the aircraft is doing or must be taken out of view.

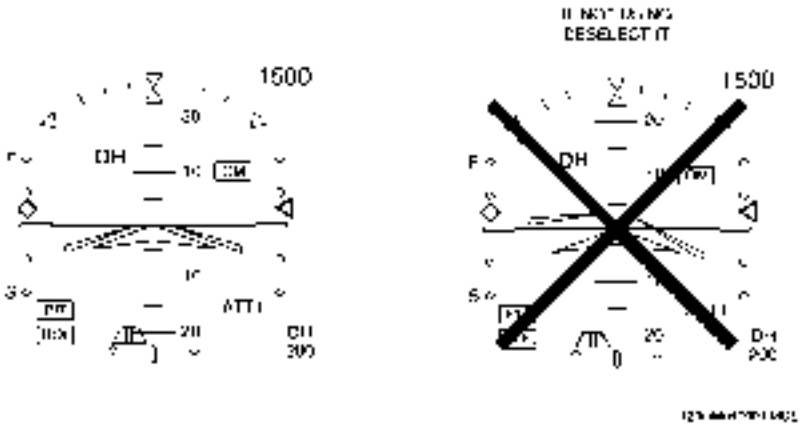

FLIGHT DIRECTOR



AUTOPILOT

Pilots must never try to counteract the autopilot. Should any undesirable autopilot behavior develop it must be immediately disconnected.

If during the autopilot-engaged flight the aircraft flies out of the FD/AP-commanded attitude the autopilot must be immediately disconnected.

The PF must keep one hand on the yoke at all times when the autopilot is coupled below 1500 ft AGL.



APPROACH AND LANDING

STABILIZED APPROACHES

Pilots must be on a stabilized approach (on track, on slope, at the target speed and configured to land) when on a three-mile final. A stabilized final approach increases touchdown precision.

Non stabilized approaches increase the risk of high sink rate at touch down or an excessive flare.

Additionally and equally important it also gives the flying pilot the opportunity to set his mind on the missed approach procedure and be prepared if he needs to do so.

Stabilized approaches do burn some extra fuel when compared with power off approaches and some other non-orthodox techniques. But trading safety for near insignificant fuel economy is not acceptable.

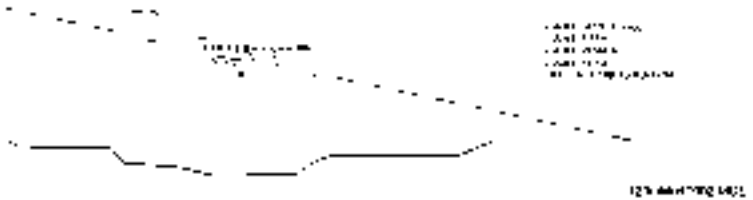

STABILIZED APPROACHES

Circle-to-land approaches are very critical because they contain a portion that lacks instrument reference and are not stabilized. These approaches must be exhaustively trained in the simulator and if the copilots are allowed to fly circle-to-land procedures in marginal weather they must be trained to do so proficiently.

Sidestepping to a parallel runway can be done if airplane is at more than three miles from touch down. Obviously there are many pilots that can do it closer to the runway and do safely, but as a safety rule to be applied to all pilots tight sidesteps must be avoided.



EFIS AND NAV USAGE DURING APPROACH

An approach based on NAV aids should never be performed based solely on GPS position. Direct NAV aid indication should always be used as primary means. However in case of a non-precision approach the GPS-based course/vertical path indication, along with the MAP mode on the MFD, can be used on the PNF side as a reference.

ILS approaches must always be performed with direct ILS indications on both sides.

MISSED APPROACH MENTALITY

There have been many accidents in commercial aviation caused by the decision to land when all evidence signaled that the safest alternative was a missed approach.

The approach must be planned with the missed approach in mind. In other words: the crew must plan a missed approach and not a landing. Landing is the alternative. This statement may not seem significant but it is. This mentality must be emphasized during training and during normal operation. The missed approach must be briefed in detail and both pilots must be totally aware of what will happen if a missed approach is carried out.

LOW SINK RATE NEAR THE GROUND

High sink rates during approach, be it an IFR approach, a visual approach or a circle-to-land maneuver, should be avoided. As a rule of thumb, two thirds of the height can be used as a target maximum sink rate when at heights of 2000 ft or less and not on the final approach segment. Therefore, as an example, at a height of 1500 ft the maximum sink rate would be 1000 ft/min, while at a height of 2000 ft the maximum sink rate would be 1300 ft/min.

Capturing the Glide Slope from above should be avoided when possible. If it is possible to alternate to a GS interception from below, the alternate procedure must be chosen.

No attempt should be made to intercept the Glide Slope from above under IMC conditions after having passed the outer marker .

Should such a situation ever arise, a missed approach should be carried out.

In the case of special unconventional procedures in critical airports, the Operations Management must decide on a case to case basis, calling for specific training and enroute instructor-assisted familiarization.



MISCELLANEOUS ITEMS

STERILE COCKPIT

Must be on below 10000 ft. This must be called out by the PF and must be advised to the cabin crew by the PNF.

SHOULDER HARNESS

Must be on during climb and descent.

ADMISSION OF CABIN CREW INTO THE COCKPIT

Only the Chief Cabin Attendant is allowed to enter the cockpit when sterile cockpit is on, and exclusively to report cabin status or for some operationally significant reason.

Cabin crew can be contacted using the following procedures:

- Via interphone: Pressing the Cab button on the audio panel in the cockpit, generates a “ding-dong” sound in the cabin, and illuminates the white CAB light on the Attendant’s Panels and headset. Cabin crew answers through the interphone;
- Via “Atdt Call”: Pressing momentarily the respective ATDT CALL button on the audio panel in the cockpit generates two “ding-dong” sound and no light on in the cabin, thus signaling the cabin attendant to come to the cockpit.

MEALS

Each flight crewmember must have his meal separately. It is recommended that they choose different menus whenever possible.

READING

In flight reading activity by the flight crew should be restricted to what is relevant and necessary for the current flight operation.



THIS PAGE IS LEFT BLANK INTENTIONALLY



SECTION 5

NORMAL PROCEDURES

Preflight Procedures.....	5-3
External Safety Inspection	5-4
Internal Safety Inspection.....	5-9
Airplane Power-Up	5-15
Normal Checklists	5-21
Detailed Checklist Description	5-26



THIS PAGE IS LEFT BLANK INTENTIONALLY



NORMAL PROCEDURES

The normal procedures are broken down into the following phases:

- PREFLIGHT PROCEDURES
- EXTERNAL SAFETY INSPECTION
- INTERNAL SAFETY INSPECTION
- AIRPLANE POWER-UP
- BEFORE START (FIRST FLIGHT)
- BEFORE START (THROUGH FLIGHT)
- CLEARED TO START
- AFTER START
- BEFORE TAKE-OFF
- CLEARED INTO POSITION
- AFTER TAKE-OFF
- CRUISE
- DESCENT
- APPROACH
- BEFORE LANDING
- AFTER LANDING
- SHUTDOWN
- LEAVING AIRPLANE

PREFLIGHT PROCEDURES

It is recommended that the Operational Dispatch personnel brief both the CPT and the F/O well before the intended operation start time.

All the weather data, TAF's, NOTAM's, intended airplane loading and other operational restrictions as applicable must be thoroughly discussed.

Briefings where both pilots participate and exchange ideas are much more effective as mind setting than for instance a briefing where only the Captain or only the Operational Dispatcher speaks.

Informing the cabin crew is important.

The Chief Cabin Attendant must be briefed on:

- Name of the flight crewmembers;
- The expected number of passengers and about any special procedure regarding passengers;
- Flight time;



- Any airplane operational restriction that affects cabin safety procedures; area to be overflown (whether overwater or not, etc.);
- Possible rough weather during which cabin service will possibly be discontinued;
- Crew meal serving and sequence if such is the case.
- The Chief Cabin Attendant must report to the flight crew:
- His (her) name;
- If cabin safety and medical equipment condition imposes restrictions or not;
- If any delay is expected regarding catering loading or passenger boarding;
- If there is any regulatory restriction regarding flight time or duty time that may cause problems at any time during the intended operation;
- If any passenger will require special handling at the destination or at any stopover;
- If the health of any passenger requires special operating care, such as a passenger with respiratory insufficiency that may require a lower cabin altitude, or a passenger that carries medical devices that may interfere with the avionics.

EXTERNAL SAFETY INSPECTION

Take time to watch the area where the airplane is parked. Evaluate if there is sufficient maneuvering room to taxi-out or perform a push-back. Make sure that there will be enough clearance throughout the required maneuver.

Also take time to inspect the airplane as a whole from a reasonable distance. See if the airplane looks good, level and normal. Experience has shown that this "initial look" can reveal details that will otherwise go unnoticed such as fluid spots on the ground, unexpected things attached to the airplane, bent or unaligned airframe components, etc.

If icing is an issue, examine the airplane external surface to determine the exact nature and extent of the airplane icing. A close inspection of critical areas such as the wing upper surface is recommended since clear ice however critical is not always visible at a distance. Advise the other pilot immediately if it helps having de-ice equipment available in a timely manner. Frost-like ice along the wing lower surface where the fuel tank stations are located comes as a result of fuel cooling during a previous long flight. This phenomenon does not have a significant effect on the airplane flight characteristics provided that frost thickness is no more than 3 mm.



If evidence is found that the airplane was anti-iced with type IV fluid before the previous flight and is not clean, a fluid residue cleanup is required.

Make sure that the airplane has the blocks and safety pins on as required. If not, advise the ground staff immediately.

The External Safety Inspection must be carried out prior to every flight.

The inspection can be done as per the checklist below:

Wheel Chocks.....	IN PLACE
NOSE SECTION	
Passenger Door	CONDITION
Battery Compartment.....	CLOSED
Air intakes and Vents	CONDITION, NO OBSTRUCTION
AOA sensors.....	CONDITION
Pitot Tubes.....	CONDITION, NO OBSTRUCTION
Static Ports.....	NO OBSTRUCTION
Ice Detector Sensor	CONDITION
Windshield Wipers	CONDITION
Radome.....	CLOSE
Nose Gear.....	CONDITION
Wheels and Tires	CONDITION
Gear/Wheelwell/Doors	CONDITION, NO LEAKS
Steering Jack Overtravel Indicator	INSIDE HOUSING
Ground Locking Pin.....	REMOVE
Nose Gear Static Discharge Wicks.....	CONDITION
Service Door	CLOSED
Taxi Lights.....	CONDITION
Hydraulic Compartment (right side)	SECURED, NO LEAKS
Oxygen Pressure Green Disc	IN PLACE
Oxygen Recharge Panel	CHECKED & SECURED
Nacelle Inspection Lights	CONDITION
Toilet Service Doors (FWD Toilet)	SECURED

SOP-120/1624



FUSELAGE

Inspection Doors and Panels	SECURED
Wing/Fuselage	CONDITION
Cabin Windows	CONDITION
Emergency Exits	CONDITION
Red Beacon.....	CONDITION
Antennas	CONDITION

WINGS

Inboard Leading Edge	CONDITION
Inboard Nacelle Vents	CONDITION
Engines.....	CONDITION, NO LEAKS
Oil Quantity.....	CHECK
Nacelle Air Intakes	NO OBSTRUCTION
Propellers and Spinners	CHECK
Outboard Nacelle Vents and Drains.....	CONDITION
Landing Light.....	CONDITION
Outboard Leading Edge	CONDITION
Fueling Compartment Doors	CLOSE
Pressure Fueling Adapter.....	CLOSE
Service Doors	CLOSE
Pneumatics Deicers (leading edge/engine air inlet)	CONDITION
Main Gear.....	CONDITION, NO LEAKS
Wheels and Tires	CONDITION
Brake Wear Indicators.....	CHECK
Gear Ground Locking Pins	REMOVE
Static Dischargers	CONDITION
Fire Extinguisher Red Disc (if installed)	INTACT, IN PLACE
Dripless Sticks.....	PUSHED IN
Flight Controls Surfaces & Fairings.....	CONDITION
Vortex Generators	CONDITION
Navigation and Strobe Lights	CONDITION



TAIL CONE SECTION

Service Doors.....	CLOSE
APU Fire Extinguisher Red Disc	INTACT, IN PLACE
APU Air Inlets.....	NO OBSTRUCTION
APU.....	NO LEAKS
Lights.....	CONDITION
Pneumatic Leading Edge Deicers.....	CONDITION
Flight Controls Surfaces.....	CONDITION
Static Discharges	CONDITION
Pressurization Static Ports	NO OBSTRUCTION
Fuselage Drain (if installed)	NO OBSTRUCTION
Baggage Door	LATCHED



The illustration below shows the walkaround sequence:

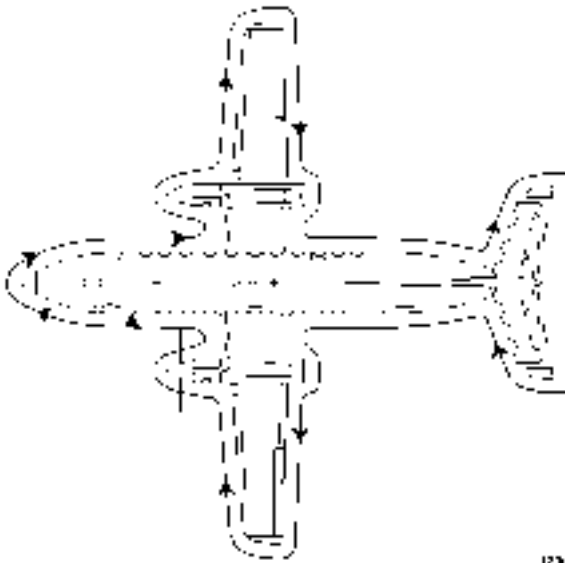

125 444 700 1401

WALKAROUND SEQUENCE



INTERNAL SAFETY INSPECTION

COCKPIT

Maintenance Status	CKD
Manuals & Documents	CKD
Cockpit Emergency Equipment.....	CKD
Gear Override & Free Fall.....	CKD
Gear Pins, Covers & Chocks	ON BOARD
Circuit Brakes.....	PRESSED
Overhead Panel	CKD
Fire Extg Handles 1 & 2	IN
Landing Gear Lever	DOWN
Radar	OFF
Radio Master.....	OFF
GPS.....	OFF
Elev/Aileron Disconnect	PUSHED IN
Passenger Oxygen Switch.....	AUTO/ GUARDED
Passenger Oxygen Rotary Switch (If installed)	AUTO/ GUARDED
Gust Lock.....	RELEASED
External Inspection.....	COMPLETED

PASSENGER CABIN

Cabin Emergency Equipment	CKD
Emergency Exits/Pax Signs	CKD
Passenger Seats and Belts.....	CKD
Galley and Toilet	CKD

The copilot prior to the first flight of the day must carry out the Internal Safety Inspection or whenever the crew-airplane combination changes. The copilot must advise the Captain when it is complete.

MAINTENANCE STATUS..... CHECKED

Check the Aircraft Log Book to ensure that all discrepancies are corrected or deferred, and that a maintenance release has been signed off. Determine any MEL restrictions.



AIRPLANE MANUAL & DOCUMENTS ON BOARD

Check the local regulations and company policy for the required on board operational documents.

For Embraer operations the following documentation must be on board:

EMB-120 MANUALS:

- Aircraft Flight Manual (AFM);
- Operations Manual (OM);
- Quick Reference Handbook (QRH);
- Normal Checklist;
- Minimum Equipment List (MEL);
- Dispatch Deviations Procedures Manual (DDPM);
- Supplementary Performance Manual;
- Route technical data for the intended operation (Runway and Drift down Analysis);
- Cruise Power Setting Tables;
- Jeppesen Manuals.

DOCUMENTS:

- Certificate of Registration;
- Certificate of Airworthiness;
- Weighing Form;
- Balance Chart;
- Certificate of Radio Station;
- Copy of the Insurance Policy;
- Accidents Reporting Forms;
- The Cabin Crew handles documents such as General Declaration and Passenger documentation, unless in specific cases when the passenger documents must legally be handed to the Captain.

COCKPIT EMERGENCY EQUIPMENT CKD

Check for the availability, status and proper location of the following Equipment:

- Escape Ropes;
- Portable Oxygen Bottle & Constant Flow Mask;
- Full Face Mask;
- Quick-donning Masks;
- Smoke Goggles;
- Flashlights;

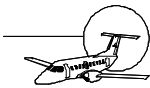

- Fire Extinguisher;
- Crash axes;
- Life vests;
- Free Fall Actuation Lever stowed.

GEAR OVERRIDE & FREE FALL..... CKD

The gear electrical override switch in the free fall lever compartment must be in the NORMAL position and guarded. The Emerg Selector must be in the NORMAL position. Each Gear Socket must be in the forward position.

CIRCUIT BRAKERS PRESSED

Verify all circuit breakers. Any breakers that are popped should be investigated. Secured Breakers should be noted in the deferred log.

OVERHEAD PANEL CKD

Overhead panel switches and knobs must be set as follows:

Inverters	ON
Bus Ties 1 & 2.....	ON
Auxiliary Generators.....	ON
Electrical Emergency Switch.....	NORMAL
Main Generators	OFF
Power Select.....	OFF
Emerg LT	OFF
Exterior & Internal Lights.....	OFF
APU Master Switch	OFF
APU Shutoff/Extg.....	GUARDED/ OPEN
APU GEN.....	OFF
APU Bleed.....	CLOSED
Electric Fuel Pumps	OFF
Electric Feather	OFF/ GUARDED
Auto Feather	OFF
Prop Sync.....	OFF
EEC.....	ON/ TO
Ignition Switches	AUTO
Rudder System	ON
Pax Cabin Air Cond SOV.....	OPEN
Anti-Skid.....	ON
Electric Hydraulic Pumps	OFF
Ice/Rain Protection.....	OFF
Prop De-ice	OFF
Eng Air Inlet.....	OFF
TAT	OFF

SOP-120/1624



- Pitot/Static OFF
- Slip Sensor OFF
- AOA Sensor OFF
- Smoke DET OFF
- Windshield Wipers OFF
- Windshield Heat OFF
- Cockpit Temp Control AUTO
- Cabin Temp Control AUTO
- W/S Defog OFF
- Recirc & Gasper OFF
- Packs 1 & 2 OFF
- Ram Air Inlet CLOSE
- Eng Bleed & Crossbleed CLOSE

- FIRE EXTG HANDLES PUSHED IN**
 Verify that Fire Extg Handles 1 and 2 are pushed IN.
- LANDING GEAR LEVER DOWN**
 Verify that Landing Gear Lever is in the DOWN position.
- RADAR & TRANSPONDER OFF**
 Check Radar & Transponder Switch to OFF position.
- RADIO MASTER OFF**
 Check Radio Master Switch to OFF position. Check NAV, COM and ADF to ON position.
- GPS OFF**
 Check GPS Switch to OFF position.
- ELEV/AILERON DISC. HANDLE IN**
 Check that handles are pushed IN.
- PASSENGER OXYGEN SWITCH AUTO/
 GUARDED**
 Check Passenger Oxygen Switch in the AUTO position and GUARDED.
- PASSENGER OXYGEN ROTARY
 SWITCH (if installed) AUTO/
 GUARDED**
 Check Passenger Oxygen Rotary Switch in the AUTO position and GUARDED.



PASSENGER CABIN

The **Flight Attendant** is responsible for checking the following equipment on the preflight inspection. The Captain will be informed if equipment is missing, not working, broken seal, or is not stored properly.

The copilot is responsible for the PASSENGER CABIN Inspection for flights without Flight Attendants.

Cabin Emergency Equipment CKD

***Fire Extinguishers**

Located below Flight Attendant's seat. Verify for validity, mounting straps are safe tied and check pressure gauge for proper charge.

***Portable Oxygen Bottle**

Verify mask condition and pressure gauge, minimum for dispatch 1200 PSI.

***First Aid Kit**

Verify validity, seal or contents/stowed.

***Medical Kit**

Verify validity and seal.

***Escape Ropes**

Verify that hand hope/snap hooks are stowed in the left rack.

***Life Rafts**

Verify validity and general condition.

***Life Vests**

Verify validity and availability for dispatch.

***Pax Adrs**

Check for proper operation of Attendant's Interphone.

Gear Pins

Check on board.

Emergency Exits/Pax Signs CKD

***Emergency Exit Lights**

Verify operation.

* (Crew or Airplane – First Flight of the Day).



***Cabin Lights & Signs**

Check operation of Cabin Lights (DIM & BRT, OFF); PSU (Reading Lights, NO SMOKING & FASTEN BELTS). The Cabin Lights must be OFF before Engines Start in order to prolong the lifetime of the cabin lights.

Emergency Exits

Verify closed.

Passenger Seats and Belts CKD

Seat Belts and Flotation Cushion

Verify condition.

***Seat Belts Extension**

Verify condition.

Emergency Evacuation Cards

Check on board.

Motion Sickness Bags

Check on board.

***Entertainment System**

Verify normal operation.

Galley and Toilet..... CKD

Toilet

General condition and cleaned.

Galley Equipment

Galley Master switch, Hot Jug switches and Galley Lighting switch to OFF (Select all switches to OFF before engine start and before engine shutdown). Verify that Trolleys, Drawers, and Closets are closed and locked. Check for general condition and cleaning.

*** (Crew or Airplane – First Flight of the Day).**



AIRPLANE POWER-UP

APU START WITH BATTERY

Battery Voltage.....	CKD
PWR Select Switch.....	BATTERY
Back-up Battery.....	CKD/ARMED
Fire Warning System	CKD
Fuel Pumps.....	ON
APU.....	ON/START
APU GEN.....	ON
Radio Master.....	ON
Air Conditioning.....	AS REQD

After completing the External and Cockpit Safety Inspection the First Officer may start the APU using the aircraft batteries as follows:

BATTERY VOLTAGE CKD

Select the Voltammeter Selector to BATTERY and check the voltage. The minimum recommended battery voltage for APU start is 22 V.

PWR SELECT SWITCH BATTERY

Select to BATTERY position.

BACK-UP BATTERY..... CKD/ARMED

Hold the Back-up Battery Switch in the TEST position, check that the Standby Horizon and Back-up Battery Indicating light illuminate, then return to ARM position.

NOTE: At test position the Back-up Battery is checked and a loss of the Emerg DC Bus 1 is simulated. The Back-up Battery will feed the Standby Horizon and Indicating light will illuminate as long as the switch is kept in the test position.

During Engine & APU start, the bus voltage may drop to 12 V DC for a few seconds and some milliseconds of power interruption may be observed on power transfer, such as EXT PWR to BATTERY or EXT PWR to GENERATOR, therefore the Back-up Battery is very important to eliminate the detrimental effect of these transients.



FIRE WARNING SYSTEM.....CKD

Press the TEST button in the glareshield to check the fire detection and extinguishing circuits. If the button is pressed for more than 10 seconds, APU is shutdown, if it is running. The following lights must illuminate:

- All lights in eng/gear wheelwell, pipe zone and APU fire control panels.
- CLOSED/fuel shutoff valve light, on the APU panel.

The following lights must flash:

- WARNING and CAUTION lights.
- FIRE APU and APU lights on the multiple alarm panel.

Aural warning must sound continuously. During test, ALARM LT switch should be selected to BRT to check the integrity of both lamps on each annunciator module.

FUEL PUMPS.....ON

Select right fuel pumps: 1 ON, 1 AUTO (or left fuel pumps: 1 ON, 1 AUTO and Crossfeed OPEN).

APUON/START

NOTE: For APU starting on ground the RADIO MASTER switches must be turned off. Set the APU MASTER switch to START momentarily, check the START CONTACTOR light illuminated till 50% RPM (APU Garret) or 70% (APU Sundstrand) and monitor EGT & RPM. After APU RPM reaches 100% check low OIL PRESS light off.



APU GEN ON

After 10 seconds the APU RPM exceeds 95%, the APU Generator will be ready to come on line. Select APU generator to ON and check if the APU Voltammeter is indicating 28 V.

RADIO MASTER ON

Select both Radio Master switches to ON.

NOTE: The AHRS 1 & 2 are energized as soon as the aircraft is energized direct from the DC BUS 1 & DC BUS 2 even with the Radio Master Switch to OFF. Check that the Bay Cooling Fans circuit breakers are IN in order to allow proper cooling of the AHRS.

AIR CONDITIONING AS REQD

Allow 3 minutes of APU warm up before adding pneumatic load.

NOTE: This procedure will reduce the thermal fatigue in the turbine wheel and consequently extend the life of major APU components.

- Switch APU Bleed to ON.
- Switch both Packs ON.
- Switch XBLEED to OPEN.
- Set both temperature controls to AUTO.
- Set Pack 2 temperature control to ATTD, if the control by the cabin attendant is desired.



APU START WITH GPU

PWR Select Switch	EXT PWR
Back-up Battery	CKD/ARMED
Fire Warning System	CKD
Fuel Pumps	ON
APU	ON/START
APU GEN	ON
Radio Master	ON
Nav Light	ON
Air Conditioning	AS REQD

After completing the External and Cockpit Safety Inspection the First Officer may start the APU using the GPU as follows:

BATTERY VOLTAGE.....CKD

Select the Voltammeter Selector to BATTERY and check the voltage. The minimum recommended battery voltage for APU start is 22 V.

PWR SELECT SWITCHEXT PWR

Select to EXT PWR position and check for proper voltage of 28 V.

NOTE: For engine starts verify GPU minimum output current of 1600 A (peak) and the recommended GPU output current is 1800 A (peak) or up.

BACK-UP BATTERY.....CKD/ARMED

Hold the Back-up Battery Switch in the TEST position, check that the Standby Horizon and Back-up Battery Indicating light illuminate, then return to ARM position.

NOTE: At test position the Back-up Battery is checked and a loss of the Emerg DC Bus 1 is simulated. The Back-up Battery will feed the Standby Horizon and Indicating light will illuminate as long as the switch is kept in the test position. During Engine & APU start, the bus voltage may drop to 12 V DC for a few seconds and some milliseconds of power interruption may be observed on power transfer, such as EXT PWR to BATTERY or EXT PWR to Generator, therefore the Back-up Battery is very important to eliminate the detrimental effect of these transients.



FIRE WARNING SYSTEM..... CKD

Press the TEST button in the glareshield to check the fire detection and extinguishing circuits. If the button is pressed for more than 10 seconds, APU is shutdown, if it is running.

The following lights must illuminate:

- All lights in eng/gear wheelwell, pipe zone and APU fire control panels.
- CLOSED/fuel shutoff valve light, on the APU panel.

The following lights must flash:

- WARNING and CAUTION lights.
- FIRE APU and APU lights on the multiple alarm panel.

Aural warning must sound continuously. During test, ALARM LT switch should be selected to BRT, to check the integrity of both lamps on each annunciator module.

FUEL PUMPS ON

Select one of the right fuel pumps ON (or one of the left fuel pumps ON and the Cross Feed switch OPEN).

APU..... ON/START

Set the APU MASTER switch to START momentarily, check the START CONTACTOR light illuminated till 50% RPM (APU Garret) or 70% (APU Sundstrand) and monitor EGT & RPM.

APU GEN ON

Select APU generator to ON.

NOTE: When APU RPM exceeds 95% +10 seconds, the APU Generator will be ready to come on-line, but as the electrical system ensures priority to the external power the APU Generator will remain off-line.

PWR SELECT SWITCH BATTERY

Select to BATTERY position and check if APU Generator comes on-line with proper voltage of 28 V.

NOTE: These procedures will minimize electrical transients.



RADIO MASTER ON

Select both Radio Master switches to ON.

NOTE: The AHRS 1 & 2 are energized as soon as the aircraft is energized direct from the DC BUS 1 & DC BUS 2 even with the Radio Master Switch to OFF. Check that the Bay Cooling Fans circuit breakers are IN in order to allow proper cooling of the AHRS.

AIR CONDITIONING AS REQD

Allow 3 minutes of APU warm up before adding pneumatic load.

NOTE: This procedure will reduce the thermal fatigue in the turbine wheel and consequently extend the life of major APU components.

- Switch APU Bleed to ON.
- Switch both Packs ON.
- Switch XBLEED to OPEN.
- Set both temperature controls to AUTO.
- Set Pack 2 temperature control to ATTD, if the control by the cabin attendant is desired.

GPU POWER (NO APU)

INTERNAL SAFETY INSPECTION.....	COMPLETED
GPU VOLTAGE.....	CKD
BATTERY SWITCH	EXT

Check the GPU voltage selecting the voltmeters to read Central Bus. The voltage should be at 28 V.



NORMAL CHECH LIST LAYOUT:

BEFORE START

Inverters	*CKD/ON.....	CPT
Battery Overtemperature.....	*CKD	CPT
Alarm Lights	*CKD	CPT
◆ Pax Signs	ON.....	CPT
Emergency Lights	*CKD&ARM.....	CPT
Prop. Aux/Elec Feather	*CKD	CPT
◆ Flaps Bit	CKD	CPT
Rudder System	*CKD/ON.....	CPT
Brakes	*CKD	C/F
Elec Hyd Pumps.....	*CKD&OFF	CPT
Ice Protection	*CKD/OFF	CPT
Air Conditioning.....	SET	CPT
Oxygen Masks	*CKD/100%.....	C/F
FD & Auto Pilot.....	*CKD&OFF	CPT
Low Speed Alarm.....	CKD	CPT
Fire Detection.....	*CKD	CPT
GPWS	*CKD	CPT
◆ Flight Instruments.....	SET&X-CKD	CPT
◆ Nav & Radios	SET	CPT
◆ Radar & Transponder.....	STBY.....	CPT
◆ Fuel Tot & Qty	SET/_Kg.....	CPT
Voice Recorder	*CKD.....	CPT
T.O. Aural Warning	*CKD.....	CPT
◆ Power Levers	G.IDLE	CPT
◆ Condition Levers	F.CUTOFF	CPT
Pax´s Oxygen.....	AUTO.....	CPT
◆ Parking Brake.....	ON.....	CPT
◆ Pressurization.....	SET	CPT
Stall Warning.....	*CKD.....	CPT
◆ Flight Recorder.....	SET	CPT
Ail & Rud Trim	ZERO	CPT
Safety Pins	ON BOARD.....	CPT
-----SHORTLY BEFORE START UP-----		
◆ Take Off Data.....	CKD/SET	CPT
◆ Elevator Trim.....	SET	CPT

◆ ON THROUGH FLIGHTS CHECKLIST



CLEARED TO START

Doors & Windows.....	CLOSED	CPT/F/O
Rotate Beacon.....	ON	CPT
Fuel Pumps	ON	CPT
Air Conditioning	OFF	CPT
Radio Master	OFF	CPT
Volt & Amp (Max 150 A).....	CKD.....	CPT

AFTER START

Electrical Panel.....	*CKD/SET	CPT
Fuel System.....	*CKD/AUTO	CPT
*Auto Feather	CKD/ON	CPT
*Prop Sync.....	ON	CPT
*EEC.....	CKD/ON	CPT
Elec Hyd Pumps.....	AUTO	CPT
Ice Protection	AS REQD	CPT
Pitot Static	ON	CPT
Air Conditioning	SET	CPT
Radio Master	ON	CPT
Ground Equipment	REMOVED	CPT
* Crew or Airplane first flight of the day		

BEFORE TAKE-OFF

Takeoff Briefing	COMPLETED	CPT
Condition Levers.....	CKD.....	CPT
Flight Director	SET	CPT
Flaps.....	15 SET	CPT
Flight Contros	CKD.....	CPT
Cabin	READY	CPT

CLEARED INTO POSITION

External Lights.....	ON	CPT
Air Conditioning	SET	CPT
Transponder	ALT	CPT
Multiple Alarm Panel.....	CKD.....	CPT
-----BELOW THE LINE-----		
Condition Levers.....	MAX RPM	CPT



AFTER TAKEOFF

AutoFeather	OFF	PNF
Air Conditioning/APU	SET	PNF
Altimeters	SET&X-CKD	PNF
Landing Gear	UP	PNF
Flaps	0	PNF
Pressurization	CKD	PNF
-----Above 10000 ft-----		
External Lights	OFF	PNF
Fasten Belts	AS REQD	PNF

CRUISE

Power Levers	SET	PF
Pressurization	CHECK	PF

DESCENT

Windshield Heat & Defog	AS REQD	PNF
Air Conditioning	SET	PNF
Landing Data	SET	PNF
Pressurization	SET	PNF
Approach Briefing	COMPLETED	PNF
-----Below 10000 ft-----		
External Lights	ON	PNF
Fasten Belts	ON	PNF

APPROACH

Windshield Heat	AS REQD	PNF
AutoFeather	ON	PNF
Altimeters	SET& X-CKD	PNF
Approach Aids	SET& X-CKD	PNF



BEFORE LANDING

Landing Gear.....	DOWN.....	PF
Flaps.....	_ SET	PF
Condition Levers.....	MAX RPM	PF
Autopilot & Yaw Damper	OFF	PF

AFTER LANDING

External Lights	SET	F/O
Fuel Pumps	SET	F/O
ICE Protection/Pitot.....	OFF	F/O
Radar & Transponder.....	STBY	F/O
Flaps.....	0°	F/O
Trim Controls.....	SET	F/O
APU	AS REQD	F/O



SHUTDOWN

Main Generators	OFF	CPT
Pax Signs	OFF	CPT
Rotate Beacon	OFF	CPT
Elec Hyd Pumps.....	OFF	CPT
Air Conditioning.....	SET	CPT
Power Levers	GND IDLE	CPT
Condition Levers	F.CUT OFF	CPT
Parking Brake	SET& X-CKD	CPT

LEAVING THE AIRPLANE

Emergency Lights	OFF	CPT
External & Internal Lights	OFF	CPT
Auto Feather	OFF	CPT
Prop Sync.....	OFF	CPT
APU/GPU	OFF	CPT
Air Conditioning.....	OFF	CPT
Back-up Battery.....	OFF	CPT
Radar	OFF	CPT
Radio Master.....	OFF	CPT
Gust Lock	LOCKED	CPT
Power Select Switch	OFF	CPT
Standby Horizon.....	CAGED	CPT



DETAILED CHECK LIST DESCRIPTION

- NOTE:**
- Read all the items in the checklist on first flight of the day or on first flight by the crew/airplane combination read only the items marked with “♦” on through flights.
 - The Daily Checks are marked with “ * ”, and are to be performed by flight crew or maintenance personnel, at operators discretion.

BEFORE START

Inverters	*CKD/ON	CPT
Battery Overtemperature	*CKD	CPT
Alarm Lights	*CKD	CPT
♦ Pax Signs	ON	CPT
Emergency Lights	*CKD&ARM	CPT
Prop. Aux/Elec Feather	*CKD	CPT
♦ Flaps Bit	CKD	CPT
Rudder System	*CKD/ON	CPT
Brakes	*CKD	C/F
Elec Hyd Pumps	*CKD&OFF	CPT
Ice Protection	*CKD/OFF	CPT
Air Conditioning	SET	CPT
Oxygen Masks	*CKD/100%	C/F
FD & Auto Pilot	*CKD&OFF	CPT
Low Speed Alarm	CKD	CPT
Fire Detection	*CKD	CPT
GPWS	*CKD	CPT
♦ Flight Instruments	SET&X-CKD	CPT
♦ Nav & Radios	SET	CPT
♦ Radar & Transponder	STBY	CPT
♦ Fuel Tot & Qty	SET/ _Kg	CPT

(Continued)



Voice Recorder	*CKD	CPT
T.O. Aural Warning	*CKD	CPT
◆ Power Levers	G.IDLE	CPT
◆ Condition Levers	F.CUTOFF	CPT
Pax´s Oxygen.....	AUTO	CPT
◆ Parking Brake.....	ON.....	CPT
◆ Pressurization.....	SET	CPT
Stall Warning.....	*CKD	CPT
◆ Flight Recorder.....	SET	CPT
Ail & Rud Trim	ZERO	CPT
Safety Pins	ON BOARD.....	CPT
-----SHORTLY BEFORE START UP-----		
◆ Take Off Data.....	CKD/SET	CPT
◆ Elevator Trim.....	SET	CPT

INVERTERS..... CKD/ON

Inverters transference:

INVERTER 2 SWITCH OFF
 Check only inverter 2 INOP light illuminated.

INVERTER 1 SWITCH OFF
 Check AC panel lights illuminated.

INVERTER 2 SWITCH ON
 Check only inverter 1 INOP light illuminated.

INVERTER 1 SWITCH ON
 Check AC panel lights OFF.

BATTERY OVERTEMPERATURE..... CKD

Press the test button on the Battery Temperature Indicator which will simulate a rising indication. When passing 70°C will trigger "BATTERY" aural warning.



ALARM LIGHTSCKD..... CPT

Hold the Alarm Lights switch in the TEST position and check flashing of the following lights and aural warning:

- WARNING light;
- CAUTION light;
- Multiple Alarm Panel (MAP);
- Aural Warning will issue a single chime.

Cancel flashing lights and aural warning by pressing the alarm cancel switch.

Check illumination of all advisory lights except for:

- APU/Engines Fire Detection & Extinguishing System lights;
- Engine Shutoff Valve lights;
- Flap Annunciator Light Bars lights;
- Emergency Battery Indication lights;
- Landing Gear Position Indication lights;
- PRESS TO TEST lights;
- FD & Autopilot lights;
- Parking Brake "ON" light (on certain aircraft).

◆PAX SIGNSON..... CPT

Once all disembarking passengers have left the airplane, turn on the FASTEN BELTS sign.

The NO SMOKING sign should be always ON.

EMERGENCY LIGHTSCKD&ARM CPT

Turn the Emergency Lights switch to ON position and check the illumination of all emergency lights and the EMERG LT NOT ARMED on the MAP.

Select the Emergency Lights switch to ARM position and check that the EMERG LT NOT ARMED light in the Multiple Alarm Panel and Emergency Lights are not illuminated.



PROP.AUX/ELEC FEATHER CKD CPT

Proceed as follow:

Condition Levers MIN RPM

Power Levers MAX REV

PROP AUX PUMP button PRESS

Press one button at a time and visually observe propeller pitch.

Decreasing or BETA light illumination, then release button.

Power Levers GND IDLE

Actuate one ELEC FEATHER switch at a time until BETA light extinguishes and propeller pitch increasing is observed.

Re-guard ELEC FEATHER switch.

Condition Levers FUEL CUTOFF

◆ FLAPS BIT CKD CPT

The flap selector lever must be at 0 position. Press Built-In Test (BIT) pushbutton and check for the normal test indication within 3 seconds:

- All light bars illuminate steady (flashing is a fault indication).
- Control Fault light illuminates.
- Flap and ADVANCED S.W.S light on MAP illuminates.
- Caution lights flashing.
- Analog indicator deenergized (the pointer of the flap position indicator moves out of its operational range).
- Press Reset (RST) pushbutton to rearm the system. It clears all memories and fault indications.



RUDDER SYSTEMCKD/ON CPT

- Ensure that the area around the landing gear doors is clear.
- Turn on Elec Hydraulic Pumps and proceed as follow:
- Steering Disengage Pushbutton.....PRESS&HOLD
- Green System Isolation SwitchOFF
 - Check INOP light on the overhead panel and RUDDER light on MAP illuminated and RUDDER light on MAP illuminated.
- Blue System Isolation Switch.....OFF
 - Check INOP light illuminated.
- Separately for each system and simultaneously for both systems, check pedals for freedom throughout full travel and centering.
- After completing the check:
- Steering Disengage Pushbutton.....RELEASE
- Green and Blue Systems Isolation Switches.....ON
 - Check both INOP lights extinguished.

BRAKESCKD CPT

Proceed as follow:

CAUTION: DO NOT RELEASE PARKING BRAKE.

- OUTBD and INBD TEST Buttons.....PRESS
- Brake Pedals (pilot and copilot's).....PRESS
 - Check respective left and right OUTBD & INBD line pressure lights illuminated.
- OUTBD and INBD TEST Buttons.....RELEASE

ELEC HYD PUMPCKD&OFF CPT

- Check fluid quantity and pressure in the green arc. Turn off the Elec Hyd Pumps.



ICE PROTECTION CKD/OFF CPT

Check the Ice Protection systems as follow:

Deicing System Monitor:

Select momentarily the MONITOR switch to TEST position. The INOP light on the monitor panel and the DEICE light on the Multiple Alarm Panel will illuminate for 2 seconds. During the next 3 seconds all lights on the deicing panels will illuminate for 2 seconds. After test time (7 seconds) all deicing systems will be revalidated. If a failure is detected in the monitor, only the monitor INOP light and Multiple Alarm Panel DEICE light will illuminate and will remain illuminated until the failure ceases.

Pitot/static 1, 2 & aux ports and SLIP, AOA, TAT sensors heating:

Turn on all on sensors and check the respective INOP light extinguished. Turn off all sensors.

Windshield heating:

Press and hold the WINDSHIELD TEST switch to left or right.

Check the illumination of:

- **INOP** light on Overhead Panel and **DEICE** on Multiple Alarm Panel (for airplanes Post-Mod. SB 120-030-0022 or S/N 120.216 and on, only the respective ON green light on the over head panel).
- **RWS** or **LWS OVERHEAT** red lights on Multiple Alarm Panel and triggering of aural warning message "**WINDSHIELD**".

Release the WINDSHIELD TEST switch.

Repeat the test to the other side.

Ice Detection System:

Press momentary the Ice Detector Test switch and check for:

- Illumination of the ice detection system **INOP** light.
- Illumination of the **ICE CONDITION** and **DE-ICE** amber lights on the multiple alarm panel.
- Triggering of the aural warning.

The complete test last approximately 3 seconds



AIR CONDITIONING.....SET CPT

If air conditioning is desired and the APU has been running for more than 3 minutes, open the APU BLEED on the APU panel and the CROSSBLEED on the air conditioning panel. Select PACKS to LOW or NORM and check that the APU EGT is within limits.

Select the recirculation fans to LOW or HIGH, as desired. Select the Gasper fan to AUTO or MIX, as desired.

NOTE: On hot days, while on ground, the recirculation fans and gasper fan should be kept off to reduce the cool-down period.

OXYGEN MASKS.....CKD/100% CPT

Both pilots must check their respective masks for oxygen supply and for microphone functionality. Check the oxygen pressure gauge on copilot's panel indicating proper pressure:

- Minimum pressure for dispatch at 21°C:
- Pilot and Copilot: 1270 psi
- Pilot, Copilot and observer: 1780 psi

Carry out the test as follow:

- Select QUICK DONNING on Crew Mask Microphone Select Switch (if installed).
- Select MASK position on the Audio Panel.
- Select SPKR on the Audio Panel and set volume to midrange.
- Set mode selector to 100%.
- Select HOT MIC on the control wheel communication switch.

Push and hold the TEST/SHUTOFF SLIDING CONTROL on the mask stowage location and check that the flow indicator (blinker) turns yellow for a short period of time, indicating that oxygen is on momentarily. The sound of oxygen flow must be heard momentarily on the speaker.

While pushing the sliding control, press the TEST/EMERGENCY button, and check again that the flow indicator (blinker) turns yellow for a short period of time.

Check the observer's mask as follow:

- Check that oxygen supply hose and microphone wiring are connected.
- Select the regulator control to 100%.
- Press the TEST/EMERGENCY button to test and check the flow indicator.



AUTOPILOT..... CKD&OFF..... CPT

The CPT must carry out the AUTOPILOT check as follow:

1. Independently, move the right and left sections of the TRIM switch up and down, and verify total absence of motion in the trim wheel, as well as TRIM failure-warning lights on.
2. Center the control column and engage autopilot. Check for proper engagement and annunciation.
3. Operate the TRIM switch up and down and check that A/P disengages.
4. Engage autopilot. Check for proper engagement and annunciation.
5. Operate the AP/PUSHER DISC switch at the same side the autopilot is selected and check for proper disengagement.
6. Transfer the autopilot, verifying for proper transfer indication.
7. Repeat item 1 to 6.
8. Reset Elevator Trim to takeoff position.
9. Move all primary flight controls through their full travel in both directions.
10. Verify that no restriction to free movement is present.
11. Ensure that no fail annunciation is present.

NOTE: In case a system fault is suspected the pilot should perform the self-test system diagnostic.

- Momentarily press the TEST button on FCP.
- Check the illumination for a few seconds of all annunciators on the Flight Control Panel and on the Auto Pilot Panel.
- Only the GA annunciator will illuminate again, indicating not a fault, but a ground test display. If any other annunciator appears, it is a fault indication. Pressing the TEST button again causes all annunciators to disappear.

LOW SPEED ALARM CKD CPT

- Press **TEST** button and check the buzzer sounding continuously and the **LOW SPEED** amber light illuminated.
- Release button. Check sound and light extinguished.



FIRE DETECTIONCKD..... CPT

Check the fire detection system if it has not been checked yet.
 Press the TEST button in the glareshield to check the fire detection and extinguishing circuits.

The following lights must illuminate:

- All lights in eng/gear wheelwell, pipe zone and APU fire control panels.
- CLOSED/fuel shutoff valve light, on the APU panel.

The following lights must flash:

- WARNING and CAUTION lights.
- FIRE APU and APU lights on the Multiple Alarm Panel.
- Aural warning must sound continuously.

During test, ALARM LT switch should be selected to BRT, to check the Integrity of both lamps on each annunciator module.

NOTE: If the button is pressed for more than 10 seconds, APU is shutdown.

GPWS (if installed)CKD..... CPT

The self-test sequence is as follows:

- BELLOW G/S light illuminates.
- Voice message GLIDE SLOPE will be heard once, one second pause.
- GPWS light illuminates.
- Several repetitions of the WHOOP-WHOOP PULL-UP voice message.

An absence of voice messages or indication lights not illuminated, during test procedures, indicates that the relevant alerts on GPWS are not available.

Self-test can be initiated on the ground or above 1000 ft by pressing and holding GPWS TEST button.



◆ FLIGHT INSTRUMENTS SET&X-CKD CPT

*EFIS CONTROL PANEL (Collins Version):

- Select the Composite Mode Switch to EADI position.
Check for proper composite format display.
- Select the Composite Mode Switch to EHSI position.
Check for proper composite format display.
- Select the Composite Mode Switch to OFF.
Select the Display Source Switch to XFR position and check the XFR light illuminated on ECP, indicating that this display is been driven from the MPU.
- Select the Display Source Switch to NORM position.
- Select the ATT AHRS Transfer Switches to XFR.
Check the ATT1 (2) yellow message in the respective EADI.
(Post-Mod. SB 120-34-0064 or S/N 120.128 check the ATT1 (2) yellow message in both EADI).
- Select the ATT AHRS Transfer Switch to NORM.
- Select the HDG AHRS Transfer Switch to XFR.
Check the HDG1 (2) yellow message in the respective EHSI
(Post-Mod. SB 120-34-0064 or S/N 120.128 check the HDG1 (2) yellow message in both EHSI).
- Select the HDG AHRS Transfer Switch to NORM.
- Select the VOR CRS DEV to ANG.

NOTE: To use LIN (linear deviation), the VOR needs DME information.

Both pilots must cross-check the instruments as follows:

- Compass Compensator Unit selected to slave mode.
- Both Airspeed Indicators indicating zero.
- Both EADI leveled and flags-free.
- Both altimeters set to the local QNH, and reading same altitudes.
- Both Vertical Speed Indicators showing zero.
- Both EHSI flags-free, showing the same magnetic heading and consistent with the magnetic compass.
- Heading bug set to the runway heading.
- Course selector set according to the expected SID.
- Altitude selector set to the assigned altitude.



NOTE: If the airplane is parked near something that could produce magnetic Interference (vehicles near wing tips or electrical cables under the airplane) there is the possibility of heading split on the PFDs. Should this be the reason for a heading split, the problem will be resolved once the airplane is moved away from that position.

◆ NAV & RADIOSSET CPT

The PF assigned for the flight must set the COMM and NAV frequencies as appropriate for the expected SID or departure procedure.

Use the VHF COMM as follow:

- COMM 1: ATC
- COMM 2: Company frequency, ATIS, VOLMET, 121.5, etc.

◆ RADAR & TRANSPONDERSTBY CPT

Verify that Radar and Transponder is in STBY. If transponder code is not available yet, select a discrete code such as 0000.

NOTE: To test the radar and transponder proceed as follow:

- COLLINS PANEL.
- WXP-85 Weather Radar Test.
- Select the Range Control Switch to 25NM (Selecting other ranges will result in an incomplete test pattern).
- Select Mode Control Switch to TEST.

Once system warm up period has elapsed, the radar self-test display should appear in the upper left side of the display.

- CTL-92 Transponder System.
- Select Mode switch to ON.
- Select ½ switch to 1.
- Press the TEST button.

The active code display intensity will modulate from minimum to Maximum. If the equipment is functioning properly, AL will be displayed in the upper window and the altitude in thousands of feet in 100-foot increments (i.e.: 7.4 is 7400 feet) will be displayed *in the lower window*.

Set the ½ switch to 2 and repeat the self-test.



*BENDIX PANEL CP-113F (forward panel)

CAUTION: • *DO NOT TURN THE RADAR ON WITHIN 15 FT OF GROUND PERSONNEL OR WITHIN 15 FT OF CONTAINERS OF FLAMMABLE OR EXPLOSIVE MATERIAL.

- *THE RADAR SHOULD NEVER BE OPERATED DURING REFUELING.

Select the EFIS controls in the following positions:

- Function Select Switch on NAV or ADF.
- Select 120 degrees sectored format display.
- Enable WX presentation on the EHSI.
- Range in 80 NM.

Select the radar controls in the following positions:

- Function switch to test.
- Tilt UP 5 (shown on the indicator display, upper right corner).

After 30 second warm up, the test pattern will appear. Check a small *ripple moving along the outer band.*

CD-422B TPR CONTROL DISPLAY

Function Selector test position. The test position performs a functional test of the receiver/decoder and displays the altitude from an encoding altimeter.

An unsuccessful test annunciates the word "FAIL" in the upper Display window. Transmission does not take place during test.

◆ FUEL TOT and QTY SET/___Kg..... CPT

Reset the Fuel Used selecting the FU page through the FUNCTION button and pulling the PULL TO SET knob for at least three seconds.

Select the FR page using the FUNCTION button and reset the fuel quantity pulling the PULL TO SET knob for at least three seconds. This procedure will set the fuel on board displayed in the instrument indicator.

VOICE RECORDER CKD CPT

Press the test button for at least five seconds to test all the channels. A GO or NO-GO indication will be given in the meter. In case of failure, the meter needle will return to zero or will be out of green band giving a definite NO-GO indication. At no time this test interrupts the voice recording.



TAKE-OFF AURAL WARNINGCKD..... CPT

Set the elevator trim out of green band. Set the left power lever to take-off position and wait for the voice message "TAKE-OFF BRAKES, TRIM, FLAPS", set the right power lever to take-off position and reduce the left power lever to GND IDLE, the voice message will continue "TAKE-OFF BRAKES, TRIM, FLAPS" and then "TAKE-OFF, BRAKES, TRIM, FLAPS, AUTOFEATHER".

Return the right power lever to GND IDLE position and the elevator trim to the green band. The test is completed.

◆POWER LEVERG.IDLE CPT

Check power levers in ground idle position.

◆CONDITION LEVER.....CUT-OFF CPT

Check the condition lever in cut-off position.

PAX OXYGENAUTO CPT

GASEOUS SYSTEM

Check the passenger oxygen toggle switch and the passenger oxygen rotary switch in auto position. Check the line pressure 1270 psi (pilot, copilot).

CHEMICAL SYSTEM

Check the PASSENGER OXYGEN TOGGLE SWITCH in auto position.

◆PARKING BRAKEON CPT

Check parking brake applied and the parking brake light ON.

◆PRESSURIZATIONSET CPT

Set the desired flight level on the inner scale of the pressurization electronic controller. Check the baro setting QNE.

STALL WARNINGCKD..... CPT

Press test button momentary to start test cycle. After 2.5 seconds, the fast/slow indicator pointer will move toward slow side, with shaker, aural warning and pusher actuating sequentially. Each subsystem pre-flight test takes 5 seconds and after it the STALL WARNING red light on multiple alarm panel and the correspondent failure warning light will extinguish if the test is successfully completed.



- ◆ **FLIGHT RECORDER** SET CPT
Set the flight number and check that all indicating lights are off. Press test button, all the lights, annunciators and segments of the digital indicators come on while the button is pressed.
- AILERON AND RUDDER TRIM** ZERO CPT
Check full deflection to the both sides and adjust to zero.
- SAFETY PINS** ON BOARD CPT
Check all the safety pins on board.
- ◆ **TAKE-OFF DATA** CKD/SET CPT
The copilot must fill the take-off card with the most current information about the airport and the take-off speeds.
- ◆ **ELEVATOR TRIM** SET CPT
Set the elevator trim according to the loading manifest sheet.

“BEFORE START CHECK LIST COMPLETED”



CLEARED TO START

DOORS & WINDOWS	CLOSED	CPT/F/O
ROTATE BEACON.....	ON	CPT
FUEL PUMPS.....	ON	CPT
AIR CONDITIONING.....	OFF	CPT
RADIO MASTER.....	OFF	CPT
VOLT/AMP (Max 150 A).....	CKD.....	CPT

DOORS & WINDOWS

CLOSED C/F
 Check cargo and forward door light off. Check left and right window closed. Check that the inscription **WINDOW NOT CLOSED**, on the window front frame is not visible to ensure that the window is closed.

ROTATE BEACON..... ON

CPT
 Turn rotate beacon light on.

FUEL PUMPS..... ON

CPT
 Close the crossfeed.
 Turn on one right electric fuel pump and one left electric fuel pump.

AIR CONDITIONING..... OFF

CPT
 Turn the both packs off.

RADIO MASTER..... OFF

CPT
 Turn the normal and emergency radio master off.

VOLT/AMP (Max 150 A)..... CKD.....

CPT
 Check Volt/Amp max 150 A before initiate the starting.

“CLEARED TO START CHECK LIST COMPLETED”



ENGINE START

The captain must always perform the engine start.

Before start the engines make sure that the amperage, when using APU is below 150 A and when using GPU make sure the voltage is 28 V DC.

NOTE: For push-back and start make sure that:

- No person or object in the danger areas.
- Doors and panels closed.
- Push back path clear.

CAUTION: ABORT THE ENGINE START BY SELECTING THE **START SWITCH** MOMENTARILY TO ABORT TO STOP FOR ANY OF THE FOLLOWING REASONS:

- IGNITION LIGHT DOES NOT ILLUMINATE WITH NH STABILIZES AROUND 25% AND CORRESPONDENT VOLTAMMETER INDICATING 400 A;
- T6 DOES NOT RISE IN 10 SECONDS AFTER FUEL OPEN;
- ABNORMALLY FAST T6 RISE OR T6 EXCEEDING THE LIMITS;
- OIL PRESSURE NOT RISING WITH "NH" AT 45% OR HIGHER;
- IGNITION LIGHT DOES NOT EXTINGUISH AFTER 50%;
- ABNORMAL SMOKE OR FLAMES COMING OUT OF THE ENGINE EXHAUST PIPE;
- ANY UNUSUAL VIBRATION OR NOISE;
- ABNORMAL PARAMETERS SHOWING ON THE GAGES.



SUGGESTED START SEQUENCE

(CPT) - "STARTING SEQUENCE WILL BE 1(2) AND 2(1)".

(GND) - "ROGER. NUMBER 1(2) ENGINE IS CLEAR".

(CPT) - "STARTING NUMBER 1(2)".

(CPT) - Turn the start switch to on momentarily, check the ignition light and calls out "IGNITION LIGHT ON" and starts the stopwatch.

(F/O) - Watches NH and calls out "TEN PERCENT".

(CPT) - Check the information and set the condition lever 1(2) to FEATHER.

(F/O) - Waits the first indication of T6 and calls out "LIGHT UP".

(F/O) - Waits for the steady rise of the oil pressure and calls out "OIL PRESSURE".

(F/O) - Check NH at about 50% (+/- 6%) and the ignition light off and calls out "IGNITION LIGHT OUT".

(F/O) - Verifies the NH indication at 60% and calls out "SIXTY PERCENT".

(CPT) - Check NH at 60% and set condition lever 1(2) to MIN RPM. Minimum oil temperature required to unfeather the propeller is 0°.

(CPT) - Check the engine parameters stabilized and calls out "IGNITION LIGHT OUT, EEC LIGHT OUT, NL AND OIL PRESSURE OK".

(CPT) - Turn the associated main generator ON to assists the second engine start.

Using GPU, do not turn on the main generator to allow the electrical system to be fed by the external power.

After the second engine start turn both generators ON and power select switch to BATT.

The starting procedure in the box must be repeated for the second engine.



If a pushback is to be performed, proceed:

NOTE: For push-back make sure that:

- GPU is not connected.
- Disengage the STEERING by pulling the circuit breaker "STEER" (B-34 Collins configuration or B-30 Bendix configuration) and verifying that the "STEER INOP" light on the MAP is illuminated.

SUGGESTED PUSH-BACK SEQUENCE

(F/O) - "STEERING DISENGAGED"

CPT) - "BRAKE IS RELEASED. CLEARED TO PUSH-BACK. STARTING SEQUENCE WILL BE 1(2) OR 2(1)". Extra information may be added here such as "AIRPLANE SHALL BE FACING NORTH" or "RUNWAY IN USE IS".

USE THE SAME SEQUENCE SHOWN IN THE PREVIOUS BOX TO START UP ENGINES

(GND) - "PUSH-BACK IS COMPLETE. PLEASE SET THE BRAKES".

(CPT) - (After setting the brakes on) "BRAKES ARE SET".

Once the start procedures are completed and the presence of the ground crew is not necessary any more:

(CPT) - "NORMAL START. YOU CAN DISCONNECT AND LEAVE. VISUAL AT MY LEFT (OR RIGHT)".

(GND) - "ROGER. DISCONNECTING. VISUAL AT YOUR LEFT (OR RIGHT)".

(F/O) - Pushes the circuit breaker "STEER" to reconnect the steering.

(CPT) - Presses the STEERING HANDLE and calls out "STEERING ENGAGED".



AFTER START

ELETRICAL PANEL.....	*CKD/SET	CPT
FUEL SYSTEM	*CKD/SET	CPT
*AUTO FEATHER.....	CKD/ON.....	CPT
*PROP SYNC.....	ON	CPT
*EEC	CKD/ON.....	CPT
ELEC HYD PUMPS	AUTO.....	CPT
ICE PROTECTION	AS REQD.....	CPT
PITOT STATIC	ON	CPT
AIR CONDITIONING	SET	CPT
RADIO MASTER.....	ON	CPT
GROUND EQUIPMENT.....	REMOVED.....	CPT

* Crew or aircraft first flight of the day.

Electrical Panel..... *CKD/SET CPT

- Main generators on and check load.
- Power select switch battery.
- All abnormal light off except aux generators.
- Check battery temperature in the green band.

FUEL SYSTEM..... *CKD/SET CPT

Follow the steps below:

- Fuel pumps OFF
- Crossfeed..... OPEN
- Low press light CYCLING
- Left front fuel pump ON
- Low press light OFF
- Left front fuel pump AUT
- Low press light CYCLING

Continue the test with all remaining fuel pumps:

After the test is complete the system must be set as follows:

- Fuel pumps AUT
- Crossfeed..... CLOSED
- Abnormal lights..... OFF



*AUTO FEATHER..... CKD/ON CPT

Check the system as follows:

Auto feather switch ARM

Test switch 1 and 2 UP

Check indicated torque at 75% and the light ARMED turned on.

Test switch 1 RELEASE

Check NP 1 approximately 20% indicating that the prop is feathered.

Test switch 2 RELEASE

Test switch 1 and 2 UP

Check indicated torque at 75% and the light ARMED turned on.

Test switch 2 RELEASE

Check NP 1 approximately 20% indicating that the prop is feathered.

Test switch 1 RELEASE

The test is completed.

*PROP SYNC..... ON..... CPT

Turn the switch on.

*EEC CKD/ON CPT

Check HMU solenoid as follows:

EEC..... ON

Check NH.

EEC..... OFF

Check NH above 50%.

EEC..... ON

Check NH.

IF NH BECOMES BELOW 50% WITH EEC OFF PROCEED:

BLEED SWITCH..... CLOSE

EEC..... MANUAL

NH..... CHECK ABOVE
50%

EEC..... ON

CAUTION: • IF NH REMAINS BELOW 50%, THE HMU SOLENOID IS FOUND TO BE LOCKED IN ENERGIZED POSITION AND THE AIRPLANE IS NOT CLEARED FOR TAKE-OFF.

- NH VALUES BETWEEN 50% AND 56% ARE ACCEPTABLE FOR THE TEST BUT DO NOT ALLOW THE RESET OF EEC. IN THIS CASE, ADVANCE POWER* LEVER UNTIL AN NH VALUE ABOVE 56% IS OBTAINED, BEFORE TURNING THE EEC ON.



ELEC HYD PUMPS.....AUTO CPT

Check the switches in the auto position, the fluid quantity and the system pressure in the green band.

ICE PROTECTION.....AS REQD CPT

Take-off under ice conditions must be performed with the ice protection as follows:

- PROPELLER HEATER.....ON
- SLIP SENSOR HEATER.....ON
- TAT SENSOR HEATER.....ON
- AOA SENSOR HEATER.....ON
- WINDSHIELD HEATER.....ON

PITOT STATICON CPT

Turn on the Pitot 1, 2 and the auxiliary.

AIR CONDITIONING.....SET CPT

With the APU on:

- Engine bleedsCLOSED
- CrossbleedOPEN
- Pack controlLOW (or NORM during hot days)
- Recirculation fanLOW
- Gasper fanAUTO (or MIX during hot days)

With the APU off:

- Engine bleedsOPEN (three minutes after start up)
- CrossbleedCLOSED
- Pack controlLOW (or NORM during hot days)
- Recirculation fanLOW
- Gasper fanAUTO (or mix during hot days)

RADIO MASTERON CPT

Turn the normal and emergency radio master ON.

GROUND EQUIPMENT.....REMOVED CPT

Do not start taxi before receiving confirmation from the ground crew that the airplane is free to taxi. Then acknowledge that and switch off the cockpit dome lights. It is recommended that the taxi light be ON during taxi even during daytime operations.

“AFTER START CHECK LIST COMPLETED”



BEFORE TAKE-OFF

TAKE-OFF BRIEFING	COMPLETED.....	CPT
CONDITION LEVER	CKD	CPT
FLIGHT DIRECTOR	SET	CPT
FLAPS	15° SET.....	CPT
FLIGHT CONTROLS	CKD	CPT
CABIN	READY.....	CPT

TAKE-OFF BRIEFING

COMPLETED..... CPT

It is recommended to perform the briefing before engine start if there is enough information about the cleared departure procedure. If the briefing is performed before engine start and there are clearance amendments afterwards or any new fact that causes significant changes in the departure procedure, the briefing must be amended.

NOTE: It is highly recommended to perform the briefing with the active participation of both pilots. Techniques such as reading back or posing questions to each other enhance this participation. Briefings done as a mechanical repetition of a memorized speech without having the mind set on the subject are useless.

The PF must perform the TAKEOFF BRIEFING according to the following guideline:

PART I

Pilots should have a detailed conversation about the intended normal departure. If weather build ups are expected shortly after takeoff, possible actions must be considered; the sequence of air traffic departure/acc, etc. must be well known to both pilots. If a SID is to be flown, the setting of navigation equipment must be well planned such as changing VOR frequencies, selected courses and altitude steps. Non-standard use of equipment such as anti-ice, radar, ignition, etc. must be addressed.



PART II

THIS WILL BE A (STATIC, NORMAL OR ROLLING), TAKEOFF WITH FLAPS __, FROM RUNWAY __, WITH V1 OF __, VR OF __, V2 OF __ AND TORQUE OF __%.

IN CASE OF AN ALERT OR ANY WARNING AFFECTING SAFETY BEFORE V1 I (or YOU if the F/O is performing the briefing) WILL ABORT THE TAKEOFF.

AFTER V1 I WILL CONTINUE THE TAKEOFF CLIMBING TO SAFETY ALTITUDE OF __FT. VFS WILL BE __.

IN CASE OF RETURN IT WILL BE VECTORS (or VISUAL CIRCUIT or INSTRUMENT APPROACH) TO RUNWAY __.

Important aspects of the departure must be discussed such as:

ESCAPE ROUTE (alternate contingency departure to avoid obstacles in case of an engine failure). The Escape Route must be discussed if the normal departure requires a climb gradient beyond the engine-out capabilities of the airplane. And it must be clear to both pilots how to transition from normal departure to the Escape Route at any point along the departure should an engine failure occur. The Escape Route chart must be available if applicable.

DEPARTURE ALTERNATE. If takeoff is to be performed below landing minima there must be a departure alternate in case of engine failure. The applicable charts must be available. An example of pertinent CPT briefings:

“THE ESCAPE ROUTE IS: AS SOON AS PRATICAL, LEFT TURN LIMITED TO 15° BANK, (...) IF ENGINE FAILS AFTER STOCKSBURG BEACON WE CAN PROCEED DIRECT TO (...)”.

“IN CASE OF ENGINE FAILURE OR ANY SITUATION THAT CALLS FOR DIVERSION TO THE CLOSEST SUITABLE AIRPORT, THE ALTERNATE AIRPORT FOR TAKEOFF WILL BE (...) YOU WILL REQUEST VECTORS TO BRIDD INTERSECTION AND ADVISE DEP CONTROL THAT WE ARE DIVERTING TO ALAMEDA AIRPORT AND TELL THEM THE REASON. THE CONTINGENCY FLIGHT LEVEL WILL BE __. I WILL LET YOU KNOW IF WE SHOULD DECLARE AN EMERGENCY (...)”.



If the same crew did the previous flight and the takeoff briefing concerning part II can be shortened as exemplified below: (part I must always be performed).

SHORTENED PART II

“THIS WILL BE A (STATIC, NORMAL OR ROLLING) TAKEOFF WITH FLAPS 15° ON RUNWAY __ WITH V1__, VR__ AND V2 __. TORQUE OF__. THE SAFETY ALTITUDE IS __ AND IN CASE OF RETURN WILL BE VECTORS (OR VISUAL CIRCUIT OR INSTRUMENT APPROACH) TO RUNWAY__.

CONDITION LEVER CKD CPT

Set condition lever to feather position and wait until propeller is fully feathered (with the power lever at GND IDLE expect NP reduction to 20% approximately) then set to MIN RPM.

FLIGHT DIRECTOR SET CPT

The PF assigned for the flight verifies that the AUTOPILOT is selected to his side then selects GA and ALT SEL on the FD panel. The flight director bar will appear showing pitch 7° UP wings leveled.

Set the first cleared altitude on the ALTITUDE ALERTER panel.

FLAPS..... 15° SET..... CPT

Set flap to 15° and check the position indicator and the overhead panel.

FLIGHT CONTROLS CKD CPT

The copilot releases the gust lock and checks AILERON and ELEVATOR free travel. Once this check is complete, the copilot must once again apply the gust lock.

Then, with the airplane taxiing in a straight line or standing still, the CPT checks the RUDDER by pressing the steering disconnect trigger on the yoke and moving the pedals from full right to full left, and pressing the steering handle to reconnect the steering system.

CABIN READY..... CPT

This item is checked after the cabin attendant has reported that the cabin is ready for departure.

“BEFORE TAKEOFF CHECK LIST COMPLETED”



CLEARED INTO POSITION

EXTERNAL LIGHTS	SET	CPT
AIR CONDITIONING	SET	CPT
TRANSPONDER.....	ALT	CPT
MULTIPLE ALARM PANEL	CKD	CPT
-----BELOW THE LINE-----		
CONDITION LEVERS.....	MAX RPM	CPT

EXTERNAL LIGHTSSET CPT

The following lights must be turned on by the CPT when entering the runway: landing lights (left and right), taxi light (if they are not ON yet) and strobe light.

AIR CONDITIONING.....SET CPT

The Air Conditioning must be set according the intended configuration (APU bleed, Eng. Bleed or unpressurized).

TRANSPONDER.....ALT..... CPT

The copilot must check that the transponder code is the correct one and is set to ALT.

MULTIPLE ALARM PANEL.....CKD..... CPT

The CPT should make sure that there is no CAUTION or WARNING lights turned ON in the MAP. If there is any light turned ON, evaluate the associated condition and its effects on the takeoff.

-----BELOW THE LINE-----

CONDITION LEVERS.....MAX RPM CPT

The copilot must set the condition levers to maximum RPM and the CPT should verify its proper position prior to takeoff.

“CLEARED INTO POSITION CHECK LIST COMPLETED”



FLIGHT CREW COORDINATION DURING TAKEOFF

When copilot is the PF and it is a STATIC TAKEOFF or NORMAL TAKEOFF, the CPT lines up the airplane on the runway, applies brakes and calls out “YOUR CONTROLS”; the copilot responds by applying the brakes too and calling out “MY CONTROLS”.

When copilot is the PF and it is a ROLLING TAKEOFF, the CPT lines up the airplane on the runway and calls out “YOUR CONTROLS”; the copilot responds by calling out “MY CONTROLS” without breaking the airplane.

The PF moves the power levers to reach 10% below the computed torque and calls out “SET TAKEOFF POWER”.

The PNF verifies that the torque reached is the target torque and that the engine parameters are normal. If everything is normal, he responds by calling out “TAKEOFF POWER SET”.

As soon as the airspeed indicator starts indicating speed the PNF call out “SPEED ALIVE”, as the airplane accelerates past 80 KIAS the PNF call out “EIGHTY KNOTS”. The PF verifies that his airspeed indicator is consistent calling out “CHECKED”.

If the PF is the copilot: once the copilot has asked “SET TAKEOFF POWER” he moves his left hand from the power levers and holds the yoke with his two hands. By this turn, the CPT moves his right hand to the power levers heads so as to be ready if an RTO becomes necessary. At V1 the CPT moves his right hand away from the power levers.

The copilot must immediately report any abnormality that can jeopardize the safety of the flight in a loud and clear voice.

If the CPT decides to abort the takeoff he must call out “ABORT” in a loud and clear voice. If the captain decides to continue takeoff he must call out “GO” in a loud and clear voice also.

The takeoff emergency and abnormal procedures are described in the respective section.

As the airplane passes V1 the PNF calls out “VEE NOE”.

As the airplane passes Vr the PNF calls out “ROTATE”.

Once a positive rate of climb is attained the PNF calls out: “POSITIVE RATE” and the PF verifies positive rate and calls out: “GEAR UP”.

The PNF commands gear up and calls out: “GEAR UP SELECTED”.

Once the three gear legs indicate up and locked the PNF calls out “GEAR IS UP”.



The PF shall maintain the pitch 7° as adjusted on the flight director before takeoff.

Once the level off is reached the PNF calls out: "LEVEL OFF" and the PF checks that the speed is $V_2 + 20$ KIAS and calls for "FLAPS ZERO, AUTOFEATHER OFF AND CLIMB POWER"; the PNF also checks the speed, selects flap zero and set the climb power (initially 84%, after transition altitude refer to the CLIMB TORQUE SETTING chart) calling out "FLAPS ZERO SELECTED AND CLIMB POWER SET".

The FD mode for takeoff should be GA + ALT SEL. The HDG BUG should be set to the heading to be used.

When a heading different from the initial runway heading is desired the PF asks the PNF to select on the FD:

"SELECT HEADING $__\circ$ "

When the PF wants to engage the autopilot he must call for "AUTOPILOT ON".

Once the autopilot is engaged the FD mode selections are done by the PF.

Upon passing the transition altitude the PNF calls out "TRANSITION ALTITUDE" and the PF responds "STANDARD AND AFTER TAKEOFF". Both pilots adjust their altimeters to QNE. The PNF verifies that both altimeters are set to QNE with consistent indications and calls out "CROSS CHECKED".

In case of operation in countries other than ICAO, an altitude reference should be established for the checklist call in place of the transition altitude.

Normally all the actions of the After Takeoff Checklist are to be performed before the checklist is asked by the PF.

The After Takeoff Check list should be read by the PNF and responded by himself. If he is interrupted by a call from ATC he should halt the reading and when he restarts it he must be sure of where he stopped. If not, the Check List must be read from start again.

Upon completing the After Takeoff Check list he must call out "AFTER TAKEOFF CHECK LIST COMPLETED TO THE LINE".



AFTER TAKEOFF

AUTOFEATHER	OFF	PNF
AIR CONDITIONING.....	SET	PNF
ALTIMETERS.....	SET & X-CKD	PNF
LANDING GEAR	UP	PNF
FLAPS.....	0	PNF
PRESSURIZATION.....	CKD.....	PNF
-----ABOVE 10000 FT -----		
EXTERNAL LIGHTS	SET	PNF
FASTEN BELTS.....	AS REQ.....	PNF

AUTOFEATHER

OFF	PNF
-----------	-----

The PNF must switch the auto feather off just after the flaps retraction.

AIR CONDITIONING

SET	PNF
-----------	-----

After transition altitude the PNF must set the air conditioning as follows:

Bleeds Switch.....	AUTO
Packs	LOW or NORMAL
Crossbleed.....	CLOSED

ALTIMETERS.....

SET & X-CKD	PNF
-------------------	-----

Upon passing the transition altitude, the altimeters are set to QNE by respective pilots if it is an operation in ICAO airspace.

LANDING GEAR

UP	PNF
----------	-----

The PNF commands gear up on request by the PF and after confirming that the rate of climb is positive. The PNF must confirm the six green UP lights.

FLAPS.....

0	PNF
---------	-----

The PNF commands flaps up as requested by the PF and according to the FLAP MANEUVERING SPEED, which is V2 + 20Kt.



PRESSURIZATION.....CKD..... PNF

Once the air conditioning system is set the PNF must verify that the pressurization is functioning properly. He must verify cabin altitude, the differential pressure and the cabin rate of climb.

-----ABOVE 10000 FT -----

EXTERNAL LIGHTSSET PNF

Upon passing 10000 ft the captain switches off the external lights except strobe and rotate beacon. The logo light also must be switched OFF.

FASTEN BELTS.....AS REQ..... PNF

Given the typically short flight time of the regional operation, the FASTEN BELTS can normally be switched off by the CPT after takeoff if condition permit. Therefore, normally at 10000 ft the FASTEN BELTS is already off. If otherwise and if the copilot is the PNF he must inform the PF (CPT) that this sign is still ON and ask him if it can be switched off.

“AFTER TAKEOFF CHECK LIST COMPLETED”



CLIMB TECHNIQUE

The climb to cruise altitude should be done choosing one of the following profiles:

- When climbing to a flight level above 20000 ft and the flight will take more than one hour, consider the use of this technique:
 - After transition altitude select CLIMB mode on the FD. The CLIMB mode will maintain 170 KIAS at sea level decreasing to 155 KIAS at 20000 ft and keeping 155 KIAS above 20000 ft (for autopilot P/N 622-8135-402 mod. 71,G). *For airplanes equipped with autopilot P/N 622-8315-302 mod 67,G the CLIMB mode will maintain 155 KIAS up to 20000 ft, then decreasing approximately 2 Kt/1000 ft to 135 KIAS at 32000 ft. **Airplanes S/N 120.290 and on have the autopilot computer P/N 622-8135-402 mod. 71,G factory incorporated.

NOTE: DO NOT GO BELOW 160 KIAS UNDER ICE CONDITION.

- If the flight is short and the cruise altitude is low (below 20000 ft), use the following profile:
 - Use PITCH HOLD mode on the FD to maintain 190 KIAS until the cruise level is reached.
 - To maintain the speed use the VERTICAL TRIM SWITCH, pressing it momentarily will provide a 0.5 of pitch change.

CLIMB POWER

Climb power must be set according to the CLIMB TORQUE SETTING table of the QRH.



CRUISE

Power Levers.....	SET	PF
Pressurization.....	CHECK.....	PF

POWER LEVERS.....SET

Set according to the Supplementary Performance Manual (SPM).

PRESSURIZATION.....CHECK..... PF

Verify the triple indicator and electronic controller for proper indication.



DESCENT

WINDSHIELD HEAT & DEFOG	AS REQ	PNF
AIR CONDITIONING	SET	PNF
LANDING DATA	SET	PNF
PRESSURIZATION	SET	PNF
APPROACH BRIEFING	SET	PNF

-----**BELOW 10000 FT**-----

EXTERNAL LIGHTS.....	ON	PNF
FASTEN BELTS	ON	PNF

WINDSHIELD HEAT & DEFOG AS REQ PNF

If the OAT is less then 10°C switch on the windshield heater.

AIR CONDITIONING SET PNF

The same setting used in cruise flight can be used. If the smell of oil is sensed in the cockpit, switch the bleeds to low.

LANDING DATA..... SET PNF

The PNF must check the destination weather conditions and fill in the landing data card (shown below) with the actual landing weight and speeds.

The speed bugs must be set as follows:

V_{REF} - Yellow Bug.

V_{REF} is the landing speed for the correct flap + wind correction,
 WIND CORRECTION = ½ STEADY WIND + FULL GUST.

$V_{APP,CLIMB}$ - White Bug.

$V_{APP,CLIMB}$ is the V_2 for the landing weight.

VFS - Green Bug.



PRESSURIZATION.....SET PNF

The PNF must adjust the cabin altitude to 300 ft below the landing field elevation by the ALT knob and the corrected landing field pressure (QNH) set by the BARO knob.

APPROACH BRIEFINGSET PNF

The approach briefing must be carried out by the PF and he must address at least the following items:

- Meteorological and runway conditions at destination LDA, contamination, prevailing winds, lighting, etc.
- Detailed discussion about the STAR and APPROACH PROCEDURE based on the applicable charts.
- The setting of the radios, selecting of nav aids, when and how to identify them, how to set courses, altitudes and heights.

Once all the check items to be performed at the top of descent are completed the PNF must call out “DESCENT CHECK LIST COMPLETED TO THE LINE”.

The approach must be planned to allow a stabilized approach for the last 3 NM before touchdown.

The missed approach procedure must be discussed in detail and both pilots must be totally aware of what to do should the need for a missed approach procedure ever arise.

Discuss about the best alternate from the company perspective that also satisfies the operational constraints. Reserve time available before proceeding to the alternate; conditions at the alternate airport. Radio aids and arrival at the alternate.

NOTE: It is highly recommended that the briefing is performed with the active participation of both pilots. Techniques such as reading back or posing questions to each other enhance this participation. Briefings consisting of mechanical repetition of a memorized speech without concentrating on the subject are useless.

-----**BELOW 10000 FT**-----



EXTERNAL LIGHTS..... ON..... PNF

The following lights must be turned ON by the captain upon crossing 10000 ft:

- Landing lights left and right and the taxi light.
- During nighttime, the logo light must also be turned ON.

FASTEN BELTS..... ON..... PNF

The captain must switch on the FASTEN BELTS light upon crossing 10000 ft, if it is not ON yet.

“DESCENT CHECK LIST COMPLETED”

DESCENT TECHNIQUE

The Descent check list must be called for by the PF, challenged and responded by the PNF, when departing the cruise level for a lower one and after the approaching briefing is completed.

The PNF must obtain the necessary meteorological information about the destination and the alternate prior to the descent. He must also carry out the company communication procedures regarding ETA, request assistance upon arrival, etc.

The TOD (Top of descent) can be estimated by taking the difference between the cruise altitude and the initial approach altitude (in thousand of feet), multiply it by three and add 5 Kt.

Example: Cruise altitude: 25000 ft
Initial Approach Altitude: 2000 ft
TOD = (25 - 2) x 3 + 5 = 74 NM

The descent can be initiated by selecting DSC on the FD after selecting the desired target altitude on the ALT SEL. Use power as necessary to maintain speed at about VMO -10 kt. The speed of VMO - 10 kt should be maintained from this point until 10000 ft when the speed must be adjusted to 250 KIAS.

NOTE: Maximum airspeed under turbulence is 175 KIAS.



APPROACH

WINDSHIELD HEAT	AS REQ	PNF
AUTOFEATHER	ON	PNF
ALTIMETERS	SET & X-CKD	PNF
APPROACH AIDS	SET & X-CKD	PNF

WINDSHIELD HEATAS REQ..... PNF

If OAT is close to or higher than 10°C, switch off the windshield heating.

AUTOFEATHER.....ON..... PNF

Turn the auto feather switch to ON.

ALTIMETERS.....SET & X-CKD..... PNF

When the altimeters are set to QNH (passing the TRANSITION LEVEL) the PF should call for the Approach Checklist, if it is a flight in ICAO airspace. If the flight is in airspace other than ICAO the checklist must be called for at an altitude established as operational standard.



APPROACH AIDS..... SET & X-CKD PNF

Both pilots must verify that the frequencies and courses that were selected are correct for the intended approach.

They must also verify that the radio altimeter alert (DH) and the GPS are properly selected for the type of approach in mind.

“APPROACH CHECK LIST COMPLETED”

CAUTION: • RADIO ALTIMETER-BASED DECISION HEIGHTS ARE NOT RECOMMENDED ON CAT-I APPROACHES. THE DECISION ON A CAT-I APPROACH HAS TO BE BASED ON THE ALTIMETER RATHER THAN ON THE RADIO ALTIMETER. THE DH ALERT IN THESE CASES IS A REFERENCE ONLY THAT MUST BE USED WITH CARE AND ITS VALIDITY DEPENDS ON THE PILOTS' KNOWLEDGE OF THE TERRAIN BEFORE THE RUNWAY.

- ALTIMETER-BASED DECISIONS ARE NOT ALLOWED ON CAT-II APPROACHES. THE DECISION ON THESE APPROACHES HAS TO BE BASED ON THE RADIO ALTIMETER.

The table below shows the flap maneuvering speeds during a visual approach or during an instrument approach:

FLAP POSITION	MANEUVERING SPEED
UP	160 KIAS
15°	140 KIAS
25°	130 KIAS
45°	120 KIAS

If fuel consumption is a consideration, consult the SPM for maximum endurance speeds (LONG RANGE charts).



The recommended CALL-OUTS for CAT-I ILS and NON-PRECISION approaches are: (IMC and VMC).

WHEN	CALL OUT	WHO CALLS OUT
At the first sign of movement of the localizer deviation bar	LOCALIZER ALIVE	PNF
Localizer Capture	SET RUNWAY HEADING	PF
When the glide slope is one dot above	GLIDE SLOPE ONE DOT	PNF
Glide slope capture	SET GO AROUND ALTITUDE	PF
Passing Outer Marker in IMC, after checking that the altitude over OM is correct	OUTER MARKER...FT ALTITUDE CROSS CHECKED	PNF
1000 ft and 500 ft above field elevation IMC and VMC	1000 ft / 500 ft above field	PNF
Any significant deviation from the LOCALIZER or GS (1 DOT) or from GLIDE SLOPE = 1 DOT or from target speed (+10/-0kt if ILS; + 10/-5kt if otherwise)	LOC or GLIDE or SPEED as appropriate	PNF
100 ft above DA or MDA if in IMC	APPROACHING MINIMUMS	PNF
When in visual contact with the approach lights or when in visual contact with the runway	APPROACH LIGHTS or RUNWAY IN SIGHT as appropriate	PNF
Reaching DA (or Mapt) without visual contact	MINIMUMS or NO CONTACT as appropriate	PNF
With or without visual contact after PNF announcement	GO-AROUND or LANDING	PF

(Continued)



WHEN	CALL OUT	WHO CALLS OUT
When decision to execute a missed approach is made	GO-AROUND, MAX POWER, FLAPS 15°	PF
When rate of climb becomes positive	POSITIVE RATE	PNF
Upon hearing the previous call out	GEAR UP	PF
At the level off altitude and V2 + 20 KIAS or faster	FLAPS ZERO	PF
When reaching VFS	SET HEADING	PF



BEFORE LANDING

LANDING GEAR.....	DOWN	PF
FLAPS.....	___°SET	PF
CONDITION LEVERS	MAXIMUM RPM	PF
AUTOPILOT & YAW DAMPER	OFF	PF

LANDING GEARDOWN..... PF

The PNF commands gear down when requested by the PF after checking if the speed is within limits for landing gear extension. Both pilots must check the six green lights before this item is confirmed.

FLAPS°SET PF

Both pilots must check that the flap position is the intended one for landing. PF responds to this item.

CONDITION LEVERSMAXIMUM RPM..... PF

The PNF must set the condition lever to the MAXIMUM RPM after the PF request. PF responds to this item.

AUTOPILOT & YAW DAMPEROFF PF

If this item is challenged when the Autopilot is still coupled, the PF must respond STAND BY; later in the approach when the Autopilot and the Yaw Damper are no longer coupled, the PNF responds.

“BEFORE LANDING CHECKLIST COMPLETED”



LANDING TECHNIQUE

The landing configuration (gear down and landing flaps) should be established early on the final approach or at the outer marker on an ILS approach.

Airspeed, power and descent rate should be stabilized early. Avoid power off approaches. Fly the airplane on a stable glide path towards the touch down point. Great changes in airspeed require great changes in power and attitude. Speed must be kept within +10Kt, -0Kt relative to the target approach speed. Unnecessary TORQUE changes of more than 10% will destabilize the approach.

Avoid excessive rates of descent during final approach; descent rates in excess of 1000 ft/min on short final should be avoided. If an excessive rate of descent develops, a missed approach must be performed immediately.

Make sure that the airplane is properly trimmed during the approach. This maximizes elevator authority for the flare or in the event of a missed approach.

As the airplane approaches the touch down point, reduce the rate of descent and slowly reduce thrust levers to flight idle so that they are at flight idle when the airplane touches down. Normally a 2° or 3° pitch change will be enough for the flare.

Plan to touch down as close as possible to the 1000 ft point. Do not allow the airplane to float in the ground effect, which unnecessarily increases the landing distance.

Apply back pressure on the yoke after the main gear touches down to smoothly ease the nose wheel onto the runway.

After positive touch down of the main landing gear reduce power levers to ground idle.

Apply forward pressure on the yoke after the nose wheel touches down to maximize directional controllability.

The reverse thrust is more effective at high speeds; the use of reverse below 60 kt increases the chances of foreign object ingestion by the engine.

To maximize braking performance on dry or wet runways apply maximum continuous pressure on the brakes for an optimum braking performance.

DO NOT PUMP THE PEDALS.

Do not fall victim to the temptation of exiting the runway too quickly, requiring heavy braking. This type of practice reduces brakes life.



AFTER LANDING

Below 60 kt and if the CPT is not the PF he takes over airplane controls and calls out MY CONTROLS and set Condition Levers to MIN. The copilot in this case hands the control to the CPT and responds YOUR CONTROLS.

EXTERNAL LIGHTS.....	SET.....	F/O
FUEL PUMPS.....	SET.....	F/O
AUTOFEATHER.....	OFF	F/O
PROP SYNC.....	OFF	F/O
ICE PROTECTION/PITOT	OFF	F/O
RADAR & TRANSPONDER.....	STBY	F/O
FLAPS	UP.....	F/O
TRIM CONTROLS.....	SET.....	F/O
APU	AS REQ.....	F/O

EXTERNAL LIGHTSSET F/O

The strobe lights must be turned off as soon as the airplane leaves the runway. However LANDING LIGHTS are switched off at the captain's discretion. The TAXI LIGHT must remain ON throughout the taxi regardless of the time of the day.

During the reading of the checklist if any light is still ON the F/O must inform the captain.

FUEL PUMPS.....SET F/O

Turn off the fuel pumps. If the APU is in use, left one right electric fuel pump on.



ICE PROTECTION/PITOT..... OFF F/O

Turn the pitot and all the other switches of the ice protection to off.

RADAR & TRANSPONDER..... STBY F/O

The copilot must check that the radar and transponder are set to STBY and press the PRE BUTTON to recall the discreet number that was stored in memory (ex. 0000).

FLAPS..... UP F/O

The copilot must retract the flaps to 0°.

TRIM CONTROLS SET F/O

The copilot must set the elevator trim to the green band and the rudder and aileron trim to zero.

APU..... AS REQ F/O

If the intention is to start the APU, do it now. Do not use the APU BLEED until the airplane is parked and with the blocks on. This will maximize the APU life (at least 3 minutes for use APU BLEED after start).

“AFTER LANDING CHECK LIST COMPLETED”



SHUTDOWN

MAIN GENERATORS.....	OFF	CPT
PAX SIGNS.....	OFF	CPT
ROTATE BEACON.....	OFF	CPT
ELECTRIC HYD PUMPS.....	OFF	CPT
AIR CONDITIONING	SET	CPT
POWER LEVERS.....	GND IDLE.....	CPT
CONDITION LEVERS	F.CUT OFF.....	CPT
PARKING BRAKE.....	ON	CPT

MAIN GENERATORSOFF CPT

If APU is ON, turn the main generators off before shutting the engine down.

If APU is not available, before turning the main generators off make sure that the GPU is connected by checking that the green GPU AVAILABLE light is on, then turn the BATT switch to EXT PWR; switch the main generators to off and check the electrical load on the CENTRAL BUS (28 V).

PAX SIGNSOFF CPT

The FASTEN BELTS lights should be switched off by CPT as soon as the airplane is static and the engines are shut down by the captain.

This will be a signal to cabin crew to initiate the procedures for deplaning of the passengers.

ROTATE BEACON.....OFF CPT

The rotate beacon should be switched off after the engines are shut down. The use of the rotate beacon should be associated with engine(s) running OR airplane in movement.

ELECTRIC HYD PUMPSOFF CPT

Once the airplane is parked with the parking brake on, the copilot must switch both electric hydraulic pumps to OFF.



AIR CONDITIONING SET CPT

After engine shut down, select the air conditioning as follows:

- Engine Bleeds CLOSE
- Crossbleed OPEN
- APU Bleed OPEN
- Packs LOW (NORM if extra cooling is needed)
- Recirc Fan LOW
- Gasper Fan AUTO

POWER LEVERS GND IDLE CPT

Check the power levers in GND IDLE and apply gust lock lever if it is necessary.

CONDITION LEVERS F.CUT OFF CPT

Check the condition levers in CUT OFF position.

PARKING BRAKE ON CPT

Typically when approaching the parking position and turning towards the marshal turn off the taxi light. This is especially important during nighttime operations.

Pull the emergency/parking brake after the airplane has stopped. Make sure that the airplane is static before pulling the emergency/parking brake.

NOTE: To avoid hydraulic fluid transfer from the green system to the blue system, first apply brakes using the pedals and after pull the emergency/parking brake handle. To release the emergency/parking brake, do the same procedure.

“SHUTDOWN CHECK LIST COMPLETED”



LEAVING THE AIRPLANE

EMERGENCY LIGHTS.....	OFF	CPT
EXTERNAL AND INTERNAL LIGHTS ..	OFF	CPT
AUTO FEATHER.....	OFF	CPT
PROP SYNC.....	OFF	CPT
APU/GPU.....	OFF	CPT
AIR CONDITIONING	OFF	CPT
STAND BY HORIZON	CAGED.....	CPT
BACK-UP BATT	OFF	CPT
RADAR	OFF	CPT
RADIO MASTER	OFF	CPT
GUST LOCK.....	LOCKED.....	CPT
POWER SELECT SWITCH	OFF	CPT

EMERGENCY LIGHTSOFF CPT

The emergency lights must be switched from ARM to OFF before the battery is switched off. Otherwise the emergency lights will go on and drain their batteries.

EXTERNAL AND INTERNAL LIGHTS...OFF CPT

Pilots must make sure that all internal and external light are switched off (with the exception of the cockpit dome light at night) before switching off GPU or APU.

AUTO FEATHER.....OFF CPT

Set the AUTO FEATHER Switch to OFF.

PROP SYNCOFF CPT

Set the PROP SYNC Switch to OFF.

APU/GPUOFF CPT

The APU is shut down when pressing the STOP button on its panel. Wait until APU rotation drops to 20% before switching the APU MASTER to OFF and BLEED switch to close.

NOTE: Do not switch off the air conditioning packs before shutting down the APU. Shutting down the APU with bleed air being extracted from it helps to extend APU life.

SOP-120/1624



AIR CONDITIONING OFF CPT

Set the air conditioning as follows:

Packs OFF
Engines bleed CLOSE
Crossbleed CLOSE
Recirculation fan OFF
Gasper fan OFF

STAND BY HORIZON CAGED CPT

Cage the STBY HORIZON. Make sure it is caged by checking whether its red flag is visible.

BACK-UP BATT OFF CPT

The back up battery must be switched from ARM to OFF before the battery is switched off. Otherwise the back up battery will feed the STBY HORIZON and the indicating light will illuminate. This may cause the back up battery to become totally drained.

RADAR OFF CPT

Switch the radar from STBY to OFF.

RADIO MASTER OFF CPT

Turn the normal and emergency radio master to off prior to switching APU or GPU OFF.

GUST LOCK LOCKED CPT

The gust lock must be applied.

POWER SELECT SWITCH OFF CPT

Switch battery to OFF.

“LEAVING THE AIRPLANE COMPLETED”



THIS PAGE IS LEFT BLANK INTENTIONALLY