

Avanti EVO

Specification and Description



Revision 7.1 April 2016

TABLE OF CONTENTS

Title	Page
1 INTRODUCTION.....	4
1.1 APPLICABLE DOCUMENTS AND REFERENCES.....	4
2 GENERAL DESCRIPTION.....	5
3 SPECIFICATIONS	7
3.1 EXTERNAL DIMENSIONS	7
3.2 INTERNAL DIMENSIONS AND VOLUMES.....	9
3.3 WEIGHTS	10
3.4 PRESSURIZATION	11
3.5 POWERPLANT	11
3.6 PERFORMANCE	12
3.7 OPERATING SPEEDS	14
3.8 PERFORMANCE CHARTS.....	15
4 AIRFRAME.....	18
4.1 FUSELAGE GROUP	18
4.2 WING GROUP	19
4.3 EMPENNAGE GROUP	19
5 POWERPLANT.....	21
6 SYSTEMS.....	22
6.1 LANDING GEAR	22
6.2 FLIGHT CONTROLS	23
6.3 FUEL SYSTEM.....	26
6.4 HYDRAULIC SYSTEM	26
6.5 ELECTRICAL SYSTEM	27
6.6 LIGHTS	28
6.7 PRESSURIZATION AND ENVIRONMENTAL SYSTEM	29
6.8 OXYGEN SYSTEM	30
6.9 ICE PROTECTION.....	30
7 INSTRUMENTATION AND AVIONICS.....	31
7.1 GENERAL	31
7.2 ELECTRONIC FLIGHT DISPLAYS	31
7.3 MULTI-FUNCTION DISPLAY (MFD).....	32
7.4 RADIO SENSOR SYSTEM	32
7.5 FLIGHT MANAGEMENT SYSTEM.....	32
7.6 WEATHER RADAR SYSTEM	33
7.7 FLIGHT CONTROL SYSTEM	33
7.8 STAND-BY INSTRUMENTS	33
7.9 ELT	33
7.10 INTEGRATED FLIGHT INFORMATION SYSTEM (IFIS).....	33
7.11 ELECTRONIC CHARTS FOR IFIS.....	33
7.12 ENHANCED MAP OVERLAY FOR IFIS.....	34
7.13 TCAS I.....	34
7.14 TAWS	34
7.15 IRIDIUM SATELLITE PHONE.....	34
7.16 ADDITIONAL FEATURES	34
7.17 PROVISIONS	34
8 STANDARD AIRCRAFT CONFIGURATION	36
8.1 AVIONICS, INSTRUMENTS AND CONTROL PANEL	36
8.2 ELECTRICAL SYSTEMS AND LIGHTS.....	37
8.3 POWERPLANT AND RELATED SYSTEMS	37
8.4 SYSTEMS.....	38
8.5 EMERGENCY EQUIPMENT	38
8.6 MISCELLANEOUS AND GROUND SUPPORT EQUIPMENT	38

9	OPTIONAL EQUIPMENT	42
9.1	INCREASED RANGE OPTION	42
9.2	AVIONICS OPTIONS	42
9.3	MISCELLANEOUS EQUIPMENT	46
10	INTERIORS	49
10.1	GENERAL	49
10.2	CABIN	49
10.3	CABIN NOISE	50
10.4	MISCELLANEOUS COCKPIT FURNISHINGS	51
10.5	INTERIOR DESCRIPTION	52
10.6	STANDARD PASSENGER INTERIOR TRIM	53
11	INSPECTIONS	73
 APPENDIX A - NOTES ABOUT THE 3-LIFTING-SURFACE DESIGN		74
 APPENDIX B – NEW AIRCRAFT WARRANTY.....		76
 APPENDIX C – OPTIONAL EQUIPMENT LIST SUMMARY		77

1 INTRODUCTION

Scope of this document is to provide a preliminary specification and description of the **P.180 Avanti EVO** configurations in order to allow the evaluation of design, performance, and equipment.

Piaggio P.180 Avanti EVO is the brand name of the latest evolution of Piaggio P.180 aircraft obtained applying several major updates to P.180 Avanti II configuration.

Data and information herein are supplied for general information purposes only and are subject to change.

The Manufacturer reserves the right to substitute equipment in lieu of that specified in this publication or modify the configuration whenever such substitution/modification is deemed necessary to comply with technical or regulatory requirements or to improve the product.

For performance data and operating limitations, reference must be made to the approved Flight Manual and other appropriate documentation.

Reference to manufacturers of parts and equipment herein are quoted just as general reference, and are therefore subject to change. Specifications, Standard Equipment and Suppliers are subject to change without notice.

All performance information herein is for the standard aircraft, prior to installation of any optional equipment, if not explicitly declared. All diagrams and schematics are for illustrative purposes only.

All reasonable care has been taken by PIAGGIO AERO INDUSTRIES S.p.A., from now on PIAGGIO, to ensure the accuracy of the information contained in this document.

However, this document does not constitute a contractual commitment, nor is it to be used in connection with the flight operation or maintenance of an aircraft.

1.1 APPLICABLE DOCUMENTS AND REFERENCES

[1] P.180 Avanti EVO – Airplane Flight Manual

2 GENERAL DESCRIPTION

The PIAGGIO P.180 Avanti EVO is a pressurized, twin-engine, three lifting surfaces, pusher propellers, turbine-powered aircraft capable of carrying up to 10 people (including crew) depending on interiors configuration and the selection of options.

The aircraft complies with the requirements of EASA CS-23 and of FAR Part 23. It has been certified by the Authorities of the European Union, United States, Canada and other countries in the transport category including day, night, VFR, IFR operations and flight into known icing conditions.

The P.180 Avanti EVO complies with RVSM operation requirements and is approved for Cat. II approach and landing operations and for steep approaches.

The Avanti EVO is designed to provide jet-like speed on turboprop fuel flows, as well as the spaciousness and comfort of a wide-body, stand-up cabin. Key to the Avanti EVO's speed and efficiency is the three lifting surface configuration and no aerodynamic compromise.

A low drag airfoil for the main wing was designed applying a NASA developed methodology, taking advantage of the pusher configuration's undisturbed airflow over the main wing to enhance laminarity.

Laminar flow over 50% of the wing chord was achieved, which compares to a maximum of 20% of wing chord normally obtained on tractor type propeller aircraft.

The Avanti EVO's forward wing is a fixed lifting surface which has flaps that move in concert with main wing flaps. The forward wing pitch angle is set so that it stalls before the main wing, producing an automatic nose-down effect; its five degree negative dihedral keeps the stream wash interference clear of the engine inlets, the main wing and the stabiliser. The global

effect of the three lifting surfaces in the Avanti EVO allows some 34% main wing area reduction, hence a proportional benefit in weight and drag.

In order to improve overall performance, the P.180 Avanti EVO is equipped with winglets and new forward wing tips, perfectly integrated in the original yet advanced aerodynamic design.

Pitch and yaw control are through a traditional T-tail arrangement and lateral control through ailerons, thus providing fully conventional handling characteristics.

All controls are fully manual and aerodynamically balanced for lightness, and the ailerons have completely sealed gaps. All three axes have electrically - powered trim tabs.

The airframe consists of 90% percent aluminum alloy and 10% composite construction. The engineer's objective was to concentrate the primary stress from the wing, landing gear and aft pressurization bulkhead on the "structural core" of the aircraft. This allowed a noticeable weight saving in that area since the same structure supports different loads at different times.

A variable cross-section, streamlined fuselage was developed to obtain both efficiency and the greatest possible interior volume. The fuselage is a monocoque structure made of conventional aluminum alloy, produced through an innovative, "outside-in" construction process, whereby large skin panels are held in place by vacuum pressure as internal structure is riveted into place. The result is a fuselage built to extremely close external tolerances, thus minimizing drag due to imperfections.

Composite materials were used only where they really made sense; in areas requiring maximum stiffness with minimum weight, such as the stabiliser, and also in areas with

intricate complex surfaces such as the engine nacelles or the winglets.

The turboprop engines are fitted with inertial particle separators and installed as pushers in low-drag, area-ruled nacelles.

Avanti EVO is designed to minimize impact on environment, significantly reducing community noise levels close to 1/2 of the Avanti & Avanti II acoustic power .

This ambitious goal has been obtained with new propeller arrangement made with a state of the art pusher propeller with scimitar blades rotating at lower rpm coupled with proprietary exhaust “shark gills” ducts that optimize hot gases impact on blades & hub and at the same type improve thrust in cruise while reducing community noise at takeoff & landing.

As a side benefit, the new propeller arrangement provides a slight improvement to the already best in class internal noise levels.

The five-bladed counter rotating scimitar propellers do not need any anti-ice system since are naturally heated by the exhaust gases.

Avanti EVO has been designed to incorporate a state of the art digital Environmental Control System that provides a fully automatic, dual zone, integrated bleed air heating and vapor cycle cooling system; automatically managing cabin and cockpit temperatures.

As an additional improvement the new digital ECS has an increased cooling power to reduce cool down time in hot weather.

The ECS package is located completely below the baggage compartment floor, thus improving everyday use of the available volume.

To improve efficiency and reliability Avanti EVO has been equipped with a state of the

art, powerful LED TAXI & LANDING light system, that achieve a light service life two order of magnitude greater than current technology, positioned on Nose & Main Landing Gear legs. As a matter of fact Avanti EVO has no incandescent bulbs on the entire aircraft.

Further design optimization is achieved removing the active lights door with associated actuation and controls.

Avanti EVO incorporate a brand new landing gear system that is designed to maintain and improve aircraft performance and at the same time reduce significantly life cycle costs.

The nose gear is equipped with a SAE Class B steering system, providing full time use during T/O & Landing with automatic engagement / disengagement; the steering system technology used on Avanti EVO is at the state of the art for the business aviation and is derived from best-in-class applications.

To provide the best possible flexibility for a variety of customer needs, Avanti EVO may include in its configuration an additional fuel tank, placed in lieu of toilet cabinet, that brings the max range up to 1,770 nm. The additional fuel tank operation is designed to be transparent to ground and flight crew.

Aiming at further operational capability, Avanti EVO may include in its configuration an advanced Anti-Skid system to improve ground handling qualities and reduce pilot workload.

3 SPECIFICATIONS

3.1 EXTERNAL DIMENSIONS

Wing		
Span (without winglets)	45.41 ft	13.84 m
Aspect Ratio	11.96	
Sweep (leading edge)	1° 11' 24"	
Dihedral	2° 00' 00"	
Area	172.22 ft ²	16.00 m ²
Wing Loading (w/o winglets)	70,26 lb/ft ²	343.04kg/m ²
Forward Wing		
Span (without wing tips)	10.76 ft	3.28 m
Aspect Ratio	4.92	
Sweep (@ 25% chord)	0° 00' 00"	
Dihedral	-5° 00' 00"	
Area	23.59 ft ²	2.19 m ²
Horizontal Tail		
Span (without fairings)	13.73 ft	4.18 m
Aspect Ratio	4.57	
Sweep (@ 25% chord)	29° 48' 00"	
Dihedral	-5°00'00"	
Area	41.27 ft ²	3.83 m ²
Vertical Tail		
Span	7.70 ft	2.35 m
Sweep (@ 25% chord)	40° 00' 00"	
Area	50.92 ft ²	4.73 m ²
Landing Gear		
Track	9 ft 4.0 in	2.84 m
Wheelbase	19 ft 0.0 in	5.79 m
Overall Dimensions		
Length (without tail tip light)	47 ft 3.2 in	14.41 m
Height	13 ft 0.7 in	3.98 m
Span	47 ft 0.9 in	14.35m

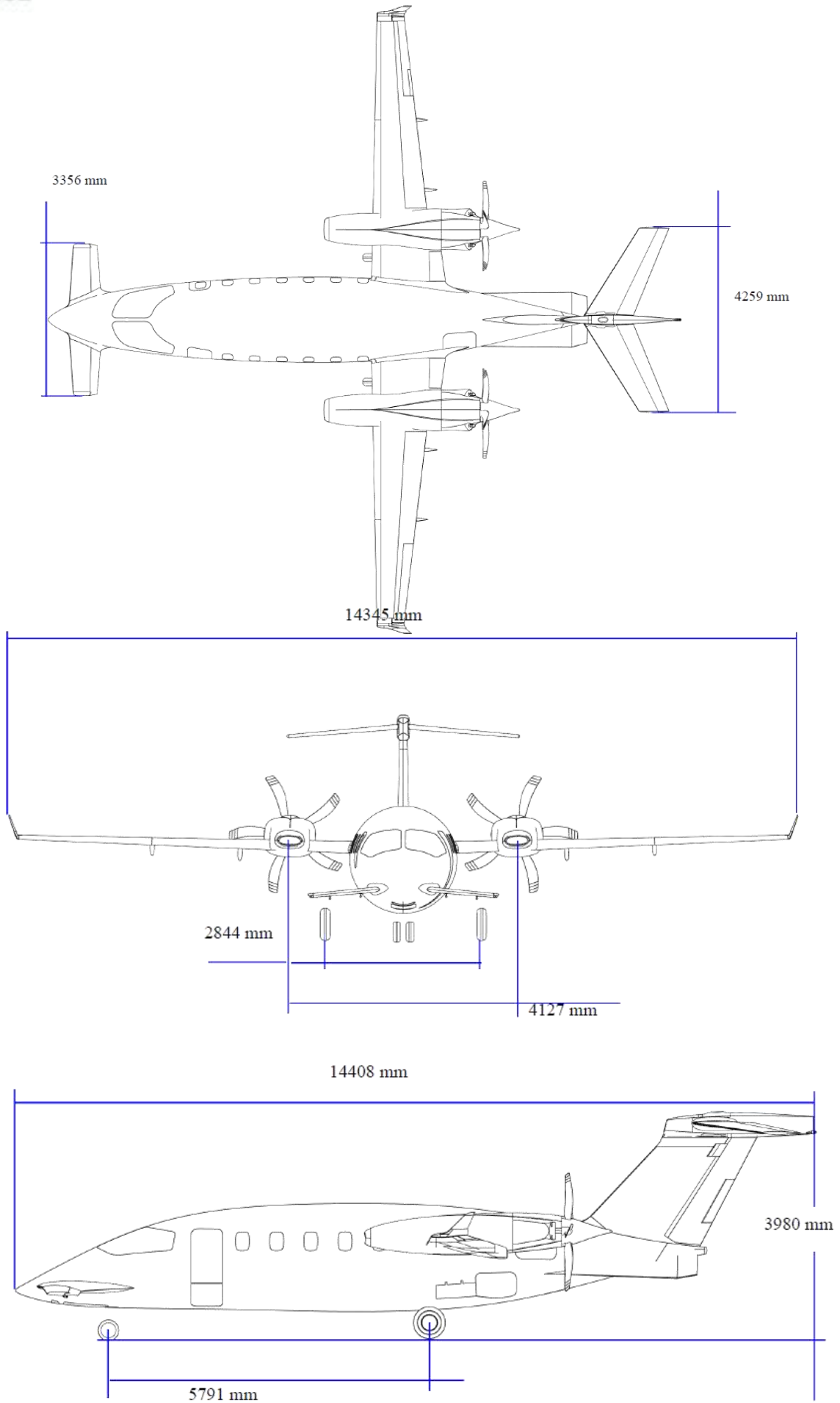

3.2 INTERNAL DIMENSIONS AND VOLUMES

Cabin Dimensions		
Height	5 ft 9 in	1.75 m
Width	6 ft 1 in	1.85 m
Cockpit Length	4 ft 9 in	1.45 m
Passenger Cabin Length	14 ft 11 in	4.55 m
including Lavatory Length	2 ft 7 in	0.79 m
Total Length	19 ft 8 in	6.00 m
Cabin Volume		
Cockpit	79.81 ft ³	2.26 m ³
Passenger Cabin	375.00 ft ³	10.62 m ³
Total Volume	454.81 ft ³	12.88 m ³
Cabin Door Dimensions		
Height	53 in	1.35 m
Width	24 in	0.61 m
Baggage Compartment Dimensions		
Total Length	5 ft 7 in	1.70 m
Total Volume	35 ft ³	1. m ³

3.3 WEIGHTS

		CORPORATE VIP	
Maximum Ramp		12150 lb	5511 kg
Maximum Take-off		12100 lb	5489 kg
Maximum Landing		11500 lb	5216 kg
Maximum Zero Fuel		9800 lb	4445 kg
Standard	Standard Equipped Empty (1)	8150 lb	3697 kg
	Standard Operating Empty (2)	8350 lb	3787 kg
	Useful Load (3)	3800 lb	1724 kg
	Usable Fuel (@ 6.70 lb/gal) (4)	2802 lb	1271 kg
	Maximum Net Payload (5)	1450 lb	658 kg
	Fuel with Max. Net Payload (6)	2350 lb	1066 kg
	Net Payload with Max. Fuel (7)	998 lb	453 kg
With Increased Range Option	Increased Range Equipped Empty (8)	8200 lb	3720 kg
	Increased Range Operating Empty (2)	8400 lb	3810 kg
	Useful Load (3)	3750 lb	1701 kg
	Usable Fuel (@ 6.70 lb/gal) (9)	3200 lb	1451 kg
	Maximum Net Payload (5)	1400 lb	635 kg
	Fuel with Max. Net Payload (6)	2350 lb	1066 kg
	Net Payload with Max. Fuel (7)	550 lb	250 kg

NOTES

- (1) Assuming standard Corporate 4 interior configuration with **De Crane** seats/divan; no options included. Does not include weight of crew. Weight may vary depending on interior configuration and options selection. **For reference only.**
- (2) Includes one pilot at 200 lbs.
- (3) Maximum ramp weight less operating empty weight.
- (4) Equal to 418.1 U.S. gallons or 1,583 litres
- (5) Zero fuel weight less operating empty weight
- (6) Useful load less maximum net payload.
- (7) Useful load less full fuel weight.
- (8) Standard Equipped Empty plus 50 lbs (net weight increased range option).
- (9) Equal to 476 U.S. gallons 1802 litres

3.4 PRESSURIZATION

The structure supports a nominal maximum cabin pressure differential 9.0 psi.

Differential	9.0 psi	.62 bar
S.L. Cabin to:	24000 ft	7315 m
Cabin altitude @ certified ceiling	6600 ft	2012 m
Certified Ceiling	41000 ft	12500 m

3.5 POWERPLANT

Engines

Manufacturer	PRATT & WHITNEY OF CANADA
Model	PT6A-66B ⁽¹⁾
Power (each) (flat rated from 1630 thermodynamic HP)	850 SHP (634 kW)
Power Loading	7.12lb/SHP (3.23 kg/SHp)
TBO	3600 hours

NOTES: (1) Equipped with torque limiter set to 2495 lb*ft.

Propellers

Manufacturer	HARTZELL
Model	HC-E5N
Diameter	86,5 in (2197 mm)
Type	Five-blade scimitar, constant speed, fully feathering, hydraulically operated
TBO	3600 hours

3.6 PERFORMANCE

3.6.1 TAKE-OFF, LANDING AND ALTITUDE PERFORMANCES

Take-off Distance ⁽¹⁾ , S.L., ISA		3196 ft	974 m
Landing Distance ⁽²⁾ , S.L., ISA (*)		3282 ft	1000 m
Rate of Climb, S.L., ISA			
MTOW	Both Engines	2950 ft/min	899 m/min
11550 lbs	One Engine Inoperative	785 ft/min	239 m/min
MTOW	Both Engines	2770 ft/min	844 m/min
12100 lbs	One Engine Inoperative	697 ft/min	212 m/min
Service Ceiling			
Both Engines		41000 ft	12497 m
One Engine Inoperative		23800 ft	7254 m

NOTES:

- (*) Distance obtained by flight testing as per the EASA/FAA rules, without propeller reversing, **distance certification pending**
- (1) FAR 23 runway requirement (2-engine Take-off to clear 50 feet) for turboprop aircraft.
- (2) Total distance over 50 feet, full flaps, without propeller reversing. Does not include any runway factors for destination or alternate airports.

3.6.2 NOISE

The aircraft is compliant with certification noise levels specified in FAR 36, Appendix G, Amdt. 16 and in ICAO Annex 16 Chapter 10.

3.6.3 CRUISE PERFORMANCE

Maximum Speed ⁽³⁾	402 KTAS	745 km/h
Cruise Speed at Maximum Cruise Power ⁽⁴⁾		
At 31000 ft	400 KTAS	741 km/h
At 35000 ft	386 KTAS	715 km/h
At 39000 ft	357 KTAS	661 km/h

IFR Maximum Cruise Range (at Maximum Range Power):

Range with Corporate VIP Configuration ⁽⁵⁾		At 39000 ft
Standard Configuration ⁽⁶⁾	1460 nm	2704 km
Standard Configuration with Increased Range Option ⁽⁷⁾	1620 nm	3000 km
Range with Shuttle Configuration ⁽⁸⁾		At 39000 ft
Standard Configuration ⁽⁶⁾	1490 nm	2760 km
Standard Configuration with Increased Range Option ⁽⁷⁾	1770 nm	3278 km

NOTES:

- (3) At 31000 feet and ISA Conditions.
- (4) Typical mid-cruise weights (operating weight + 4 PAX + 1/2 full fuel) ISA conditions and IFR reserves.
- (5) Assuming standard Corporate 4 interior configuration with De Crane seats/divan; no options included.
- (6) Mission with 1 pilot + 4 PAX, ISA conditions, zero wind.
- (7) Mission with 1 pilot + 4 PAX, ISA conditions, zero wind. additional fuel tank configuration
- (8) Assuming Layout Option 10 interior configuration with High Density seats; no options included.

3.7 OPERATING SPEEDS

Stall Speed, Landing Configuration		
VSO	95 KIAS	176 km/h
Maximum Operating Speed Limits		
VMO	260 KIAS	482 km/h
MMO	0.7 Mach	
Maximum Flap Operating Speeds		
VFO flaps MID	170 KIAS	315 km/h
VFO flaps DN	150 KIAS	278 km/h
Maximum Flap Extended Speeds		
VFE flaps MID	183 KIAS	339 km/h
VFE flaps DN	177 KIAS	326 km/h
Maximum Landing Gear Operating Speed		
VLO	181 KIAS	335 km/h
Maximum Landing Gear Extended Speed		
VLE	185 KIAS	343 km/h
Minimum Control Airspeed		
VMCA	100 KIAS	185 km/h
Maneuvering Speed		
VA	202 KIAS	374 km/h

3.8 PERFORMANCE CHARTS

P.180 - Flight Envelope

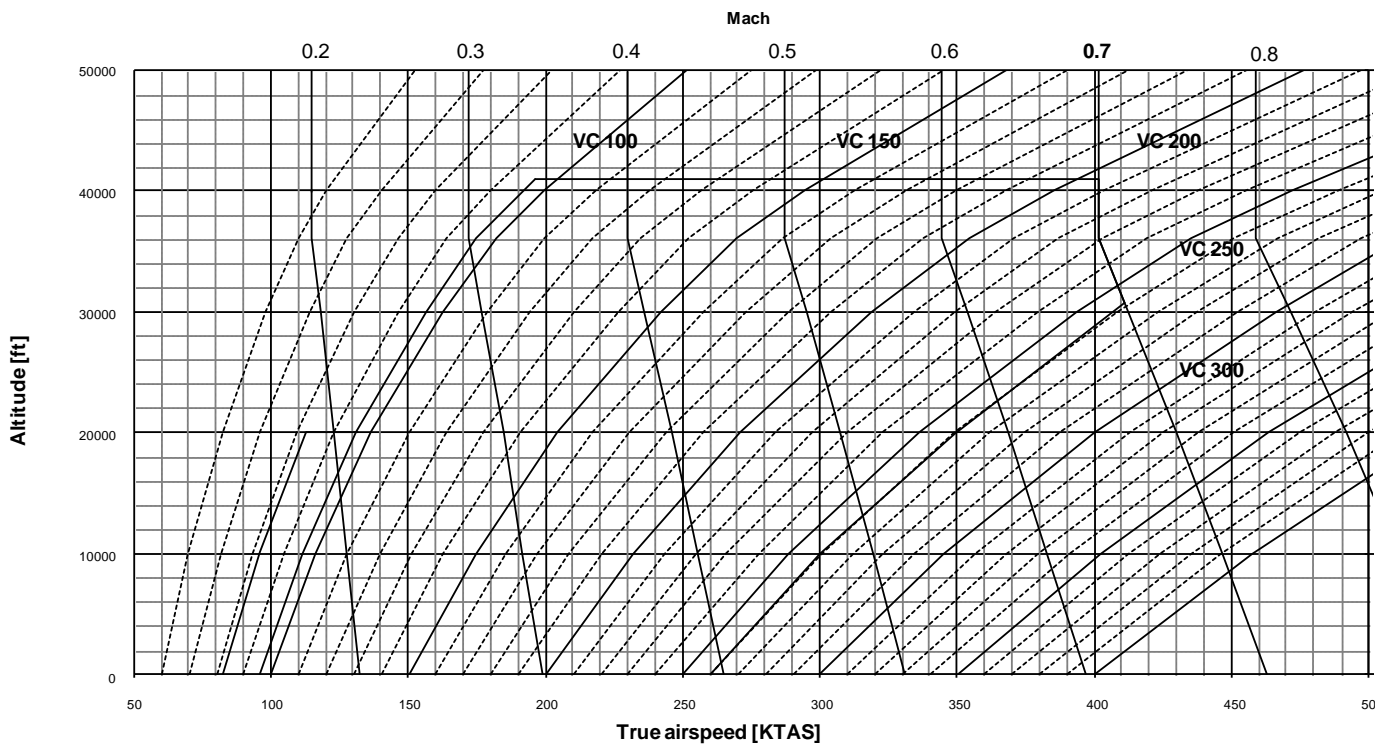

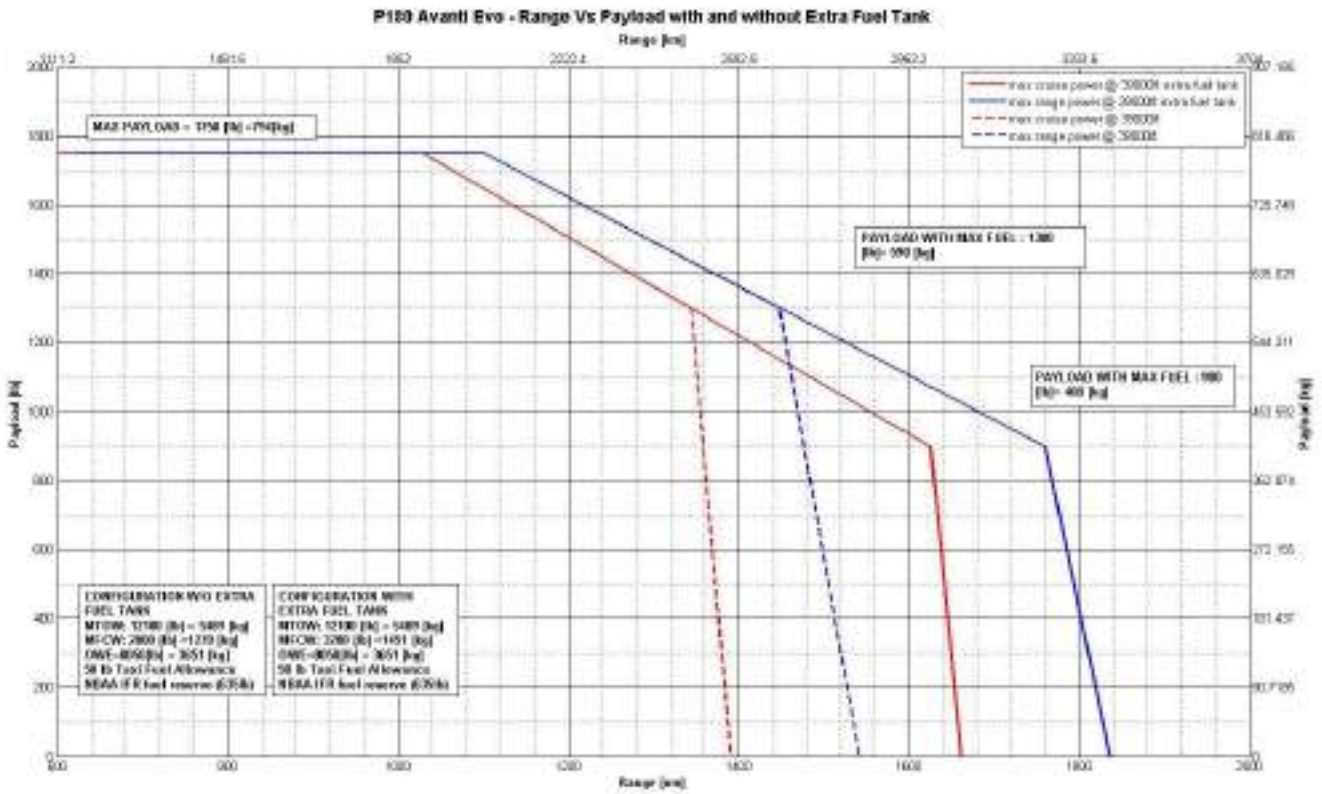

Avanti EVO Range Vs Payload with and without Extra Fuel Tank
(Chart referred to Shuttle Layout)

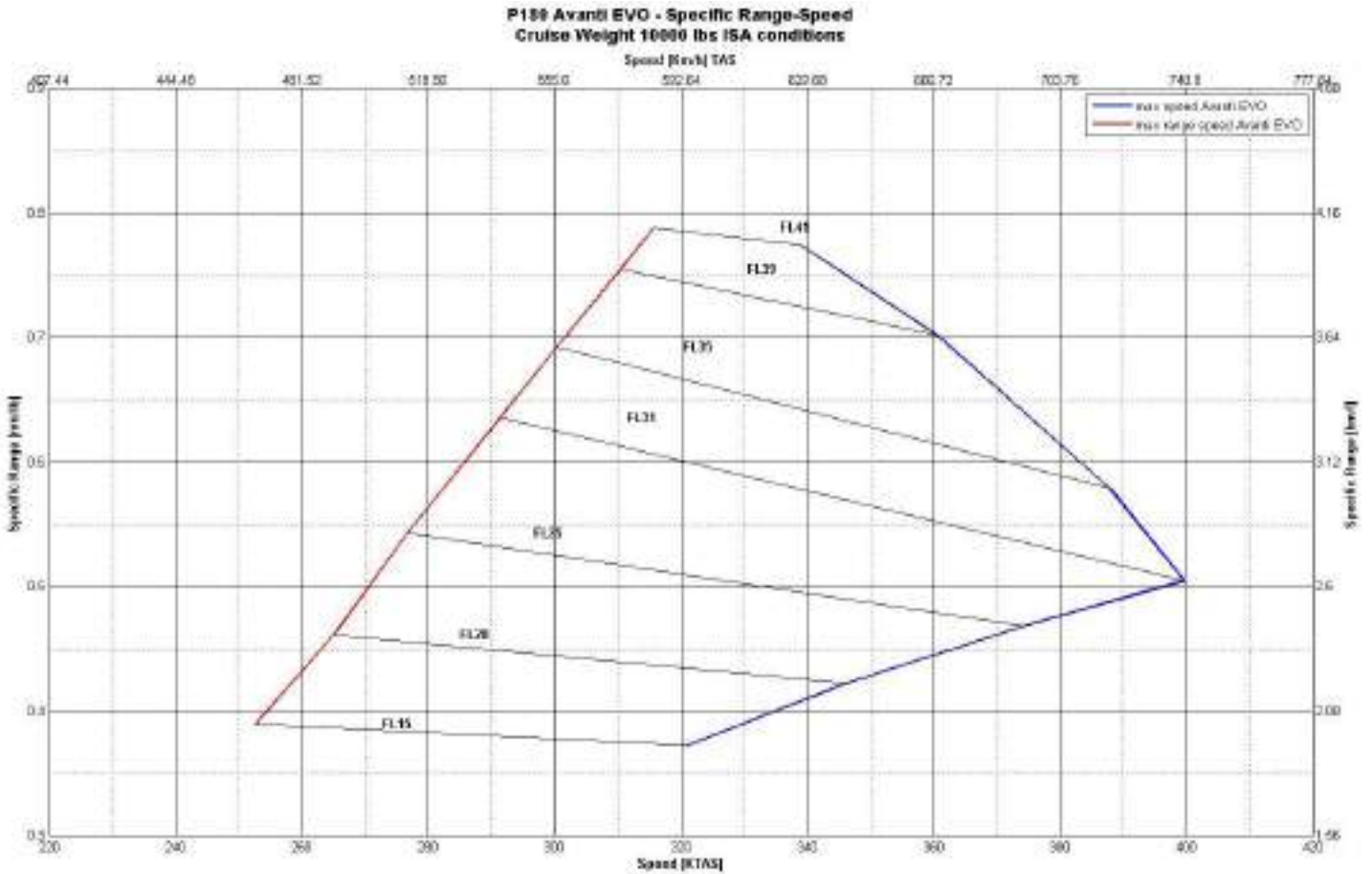

Avanti EVO Specific Range Speed
(Cruise Weight 10,000 lbs, ISA Conditions)

4 AIRFRAME

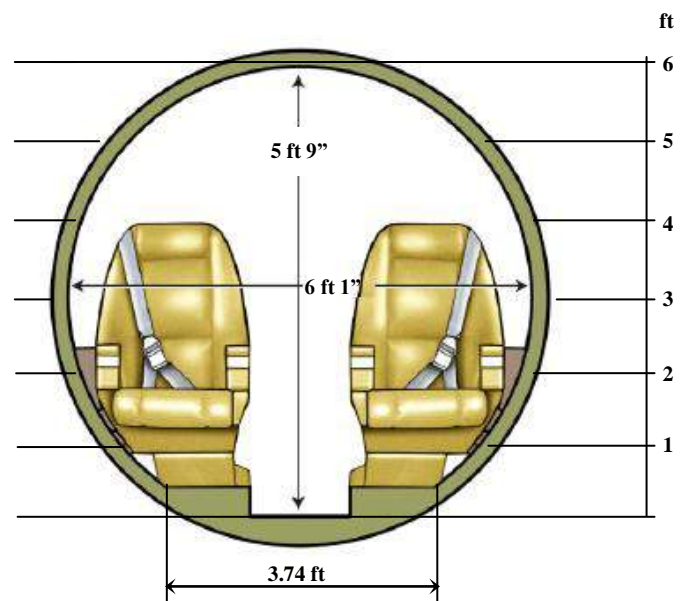
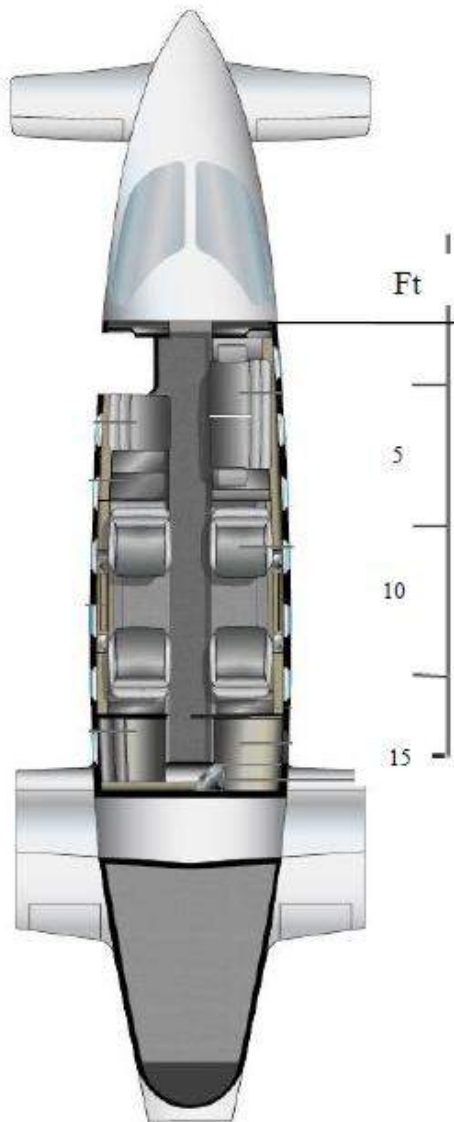

4.1 FUSELAGE GROUP

Avanti EVO's aluminum fuselage is circular in cross section and tapers both fore and aft. Cabin width extends to 6 feet 1 inch (1854 mm) and a dropped aisle provides a cabin height of 5 feet 9 inches (1753 mm). The two-part cabin door is located on the

left-hand side of the fuselage and is 53 inches (1346 mm) high and 24 inches (610 mm) wide. The upper half of the door is side-hinged and swings forward to open. The lower cabin door, which has two steps, is bottom-hinged and opens downward.

A plug-type emergency exit hatch is located on the right-hand side of the cabin immediately opposite the cabin door.

The aft fuselage extends from the aft pressure bulkhead to the tail-cone and is divided into two sections: the wing/fuselage intersection area and the baggage compartment area.

Within the wing/fuselage intersection area, the space over the wing and between the forward and central bulkheads contains an integral fuel tank. This tank is divided into two parts by a centre panel and is interlinked with the wing tanks. Located in the fuselage beneath the wing are most major accessories.

The baggage compartment is located in the aft part of the fuselage between the third wing spar and the tail-cone.

Baggage compartment length is 5 feet 7 inches (1700 mm) and total volume is 35 cubic feet (1.00 m³). The baggage door is a composite part and is hinged at the top.

The tail-cone is attached to the rear fuselage and supports the empennage.

4.2 WING GROUP

Avanti EVO is a three-lifting-surface design using a forward wing, an aft fuselage, mid-mounted main wing, and a stabiliser at the tail.

The wing is characterized by an aspect ratio of 11.96, a taper ratio of .34, a dihedral of 2° and a swept of 1°11' (leading edge). The airfoil thickness varies from 13% at the tip to 14.5% at the nacelle; inboard the nacelle, the wing has an average thickness of 13.5%.

The wing is provided with a carbon fiber winglet which is characterized by an aspect ratio of 1.39, a taper ratio of 0.54, a cant angle of 19.2°, a sweep angle of 45.33° at leading edge, a toe angle of 1°.

The high-aspect-ratio main wing is constructed of aluminum alloy. The wing main box is a working skin type (wing panels and spars are machined, stiffeners

are integral) with two main spars. The wing has a third spar running from the nacelle to the fuselage centerline. Connected to the main box are an aluminum leading edge and aluminum and composite trailing edges. The wing incorporates inboard single-slotted flaps, outboard Fowler flaps, ailerons and engine support structure (engine cradles are made of titanium alloy). The wing contains an integral fuel tank out to 21.34 feet (6503 mm) from fuselage centre line. Wing leading edge anti-ice is accomplished by directing engine bleed air through a diffuser duct installed in the main wing leading edge.

The forward wing is an all aluminum alloy unit. The wing main box is a working skin type (wing panels and spars are machined, stiffeners are integral) with two main spars, like the main wing, and is attached to the lower fuselage at four points. The aluminum alloy leading edge, contains an electrically-activated de-icing blanket. Single-slotted forward wing flaps are full-depth honeycomb aluminum parts. The forward wing tip is an Hoerner tip like shape, it is in fiberglass and has an aerodynamic re-balancing function that undoes the increasing of aircraft pitching moment due to the winglet installation.

4.3 EMPENNAGE GROUP

The tail group consists of a fixed vertical fin, two ventral (delta) fins, a movable stabiliser with elevators, and a rudder with trim tab.

Aerodynamically and mass-balanced elevators are made of full-depth aluminum honeycomb with aluminum skins and a single spar. Each elevator is actuated by means of an aluminum torque fitting attached to the inboard end of the spar.

The all-movable stabiliser is a two spars sandwich construction of graphite fabric, surrounding a Nomex honeycomb core.

The vertical fin is attached to the tail-cone bulkheads by four vertical aluminum machined spars. Skins are of aluminum

sheet chemically milled to reduce weight.

The rudder is a two spars structure with spars and skin in aluminum alloy; it has a trim tab located in its trailing edge. The rudder is aerodynamically balanced by a leading edge horn and mass balanced by

adjustable weights in this horn. The rudder is actuated by means of an aluminum torque fitting attached to the lower end of the front spar and to the reinforced lower close-out cap.

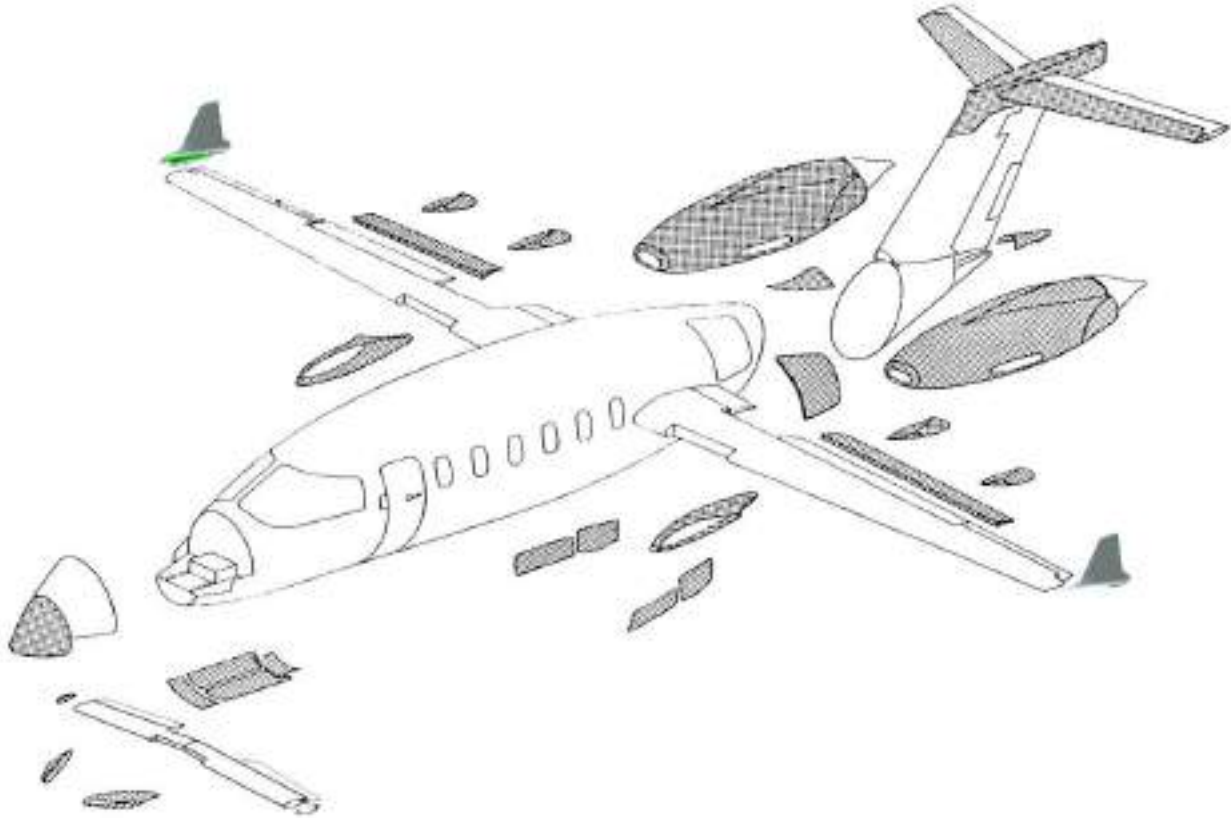

Composite Components

5 POWERPLANT

Two Pratt & Whitney Canada PT6A-66B turboprop engines are mounted in titanium engine cradles atop the main wing in composite-construction nacelles.

The PT6A-66B is a light-weight, free-turbine engine, with a maximum thermodynamic rating of 1,630 (1,215 kW) horsepower and flat rated to 850 shaft horsepower (634 kW). Each engine utilizes two independent turbine sections: one driving the compressor in the gas generator section and the second one (a two-stage power turbine) driving the propeller shaft through a reduction gearbox. Fire warning is provided by a continuous-type thermal detector running through each engine compartment around and along the engine.

The fire protection system installed on P.180 Avanti EVO detects the presence of a fire or of a local overheat condition in the engine fire zones. The engine fire extinguishing system discharges extinguishing agent into the fire zones when it is activated by the flight crew.

Two identical systems are installed, one for each engine. The fire bottles are carbon-halon steel containers attached to the engine mounting frames. The stainless steel tubes and nozzles duct the extinguishing agent to the fire zones and to the propeller gearbox zones.

The system is activated through two lighted pushbuttons installed on glareshield left and right sides. They are guarded to prevent inadvertent discharge of the fire bottles.

The engine fire extinguishing system has been certified on a non-dangerous basis. No

tests to demonstrate the extinguishing agent concentrations in nacelle zones have been carried out.

The engines drive two Hartzell, five-bladed, aluminum, counter-rotating, pusher propellers scimitar type optimized for 1800rpm, with the left-engine propeller turning clockwise and the right-engine propeller turning counter-clockwise. The left engine is equipped with a standard gearbox which incorporates a modification allowing reverse prop shaft rotation. The aircraft has no critical engine due to opposite-rotation propellers. Woodward propeller governors are fitted with an integral Beta valve, permitting reverse thrust operation. The propellers are also equipped with an autofeather system.

The P180 is equipped with a propeller synchrophaser system as to reduce noise during cruise, controlling the relative phase between propellers and, based on phase error, changing props RPM to restore the selected relative phase position.

The synchrophaser system may be engaged after takeoff and automatically disengages in the case of in-flight engine shut-down or propeller feathering.

The P.180 is equipped with conventional push-pull manual controls including, for each of the two power plants, an engine power output control lever and a combined propeller control and fuel condition lever.

These levers are mounted together in a control box assembly located on the control pedestal in the flight compartment, with Power Levers on the left side and Condition Levers on the right.

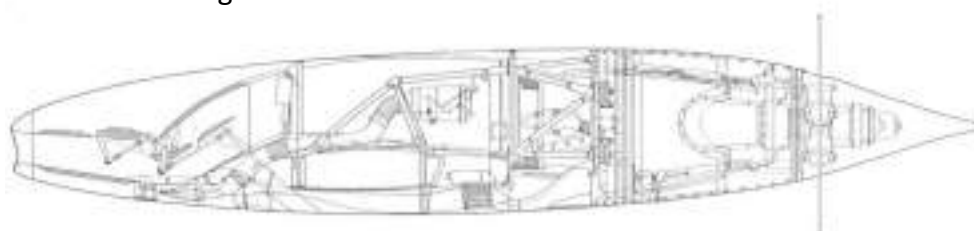

Engine nacelle section

6 SYSTEMS

6.1 LANDING GEAR

The landing gear is hydraulically operated and fully retractable. Shock absorption on all three gear is via air-oil struts. The double-wheel nose gear retracts forward into the nose section, while the single-wheel main gear retract backwards into the aft fuselage. Doors completely cover the retracted gear. The rear door of the nose-gear well and the forward doors of the main-gear strut wells remain open when the gear is extended. The side-hinged wheel well doors of the nose gear and the aft doors of the main gear open with gear extension and then close when the gear is fully extended.

The nose gear is equipped with an electro-hydraulic Class B (according to SAE ARP1595) steering system with an integrated rack-and-pinion type steering actuator.

The nose gear is steerable through 50 degrees left and right in the TAXI mode, and 7 degrees left and right in the Take-Off & Landing mode.

Full time use during T/O & Landing with automatic engagement / disengagement.

The steering system is automatically armed when nose landing gear is down-and-locked; when in air it will command nose wheels centered while when on ground it will automatically select Take-Off & Landing mode. Pilot selection is required to operate in Taxi mode.

The electro-hydraulically operated nose-gear steering is controlled through the rudder pedals.

A control-wheel-mounted push button is used to select the steering mode.

Both pilot and copilot can disarm the steering system at any time via the Control

Wheel Master Switches located on pilot's and copilot's control wheel handles.

The system shall automatically disarm upon gear retraction or failure detection.

The landing gear can be extended at speeds up to 185 KIAS. The gear actuators incorporate both internal up and down locks. A warning horn will sound under the following circumstances:

- the landing gear is not locked down and power is reduced below a setting sufficient to maintain level flight;
- the flaps are lowered to the down position without the gear locked in the down position;
- the flaps are set to the mid position and the left power lever is retarded approximately below the half-travel position.

The emergency landing gear extension system consists of a hydraulic hand pump, an emergency select valve and emergency lines from the fluid reservoir to the actuators.

Toe-actuated BF Goodrich carbon disc brakes are installed on the main gear wheels. Brakes are hydraulically actuated through a primary system or a secondary, emergency system.

There are three discrete flap positions controlled by micro-switches: up, mid-takeoff position, down-landing configuration. From the up- to the mid-setting, flap deployment takes 16 seconds. Flap travel is sequenced to minimize pitch change through flap deployment. From the mid setting, all flaps descend simultaneously to the down setting in five seconds.

Flaps retract simultaneously to the mid position in five seconds. From the mid position flaps retract simultaneously to the up position in 16 seconds.

The flap position indicator, shown on the central Multi Function Display, provides the crew with visual indication of flap surface positions.

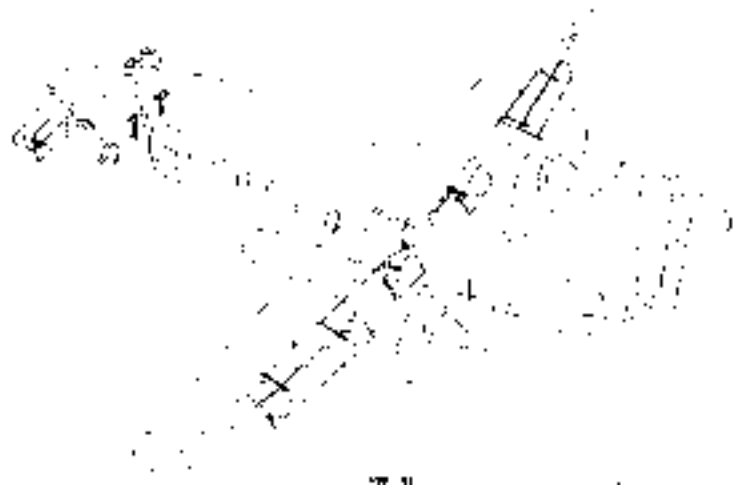

Flap System

6.3 FUEL SYSTEM

The fuel system has a baseline total fuel capacity of 421.9 U.S. gallons (2,848 lbs, 1,597 liters), with a usable fuel of 418.1 U.S. gallons (2,802 lbs, 1,583 liters).

Each engine is fed by its own fuel system made up of four interconnected tanks: an integral fuselage tank just above the wing, a wet-wing tank, one fuselage under-wing collector tank and one auxiliary collector tank also located in the fuselage below the wing.

The aircraft can be optionally equipped with an additional fuel tank to improve aircraft flight range by increasing the available fuel volumes without affecting present MTOW.

The tank add 58 U.S. gallons (390 lbs, 220 litres), for a total fuel capacity of 480 US Gallons, with usable fuel system capacity of 476 U.S. gallons (3218 lbs, 1,802 litres).

The additional fuel tank has been designed to avoid any extra work to the crew both in air and on ground, since refueling and unloading operations remain unchanged (ref. § 9.1 for further details).

The left and right fuel systems are independent except during pressure refueling operations, during which a valve-controlled interconnecting duct connects the left and right collector tanks. A single point pressure refueling adapter is provided on the right side of the fuselage under the wing.

All the fuel is supplied to the engine from the fuselage collector tank. Two electrically-driven submerged boost pumps, located at the bottom of the collector tank, are connected to the fuel low pressure line to the engine. The main boost pump normally supplies fuel to the engine driven fuel pump; the stand-by pump automatically

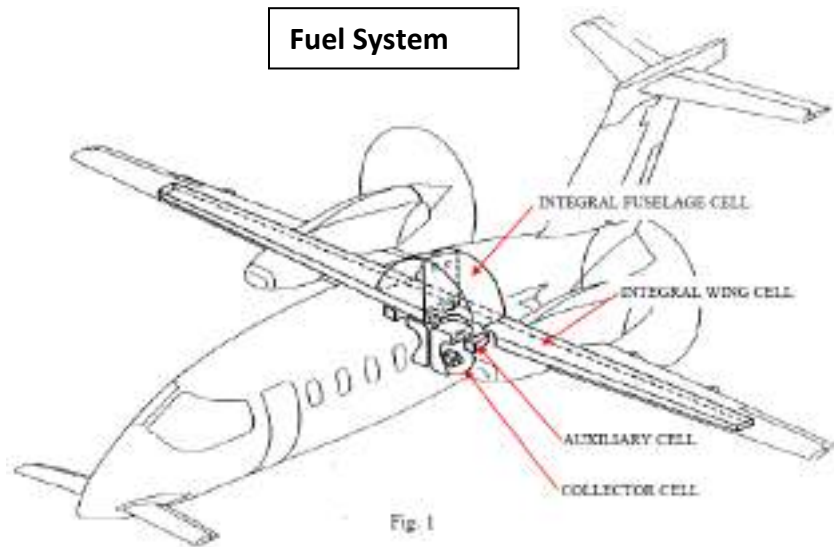

switches on in the event of main pump failure.

A capacitance-type fuel gauging system is used to indicate the fuel quantity, which is shown in pounds. The fuel tanks have been coated to provide corrosion resistance and protection against micro-organism damage.

6.4 HYDRAULIC SYSTEM

The hydraulic system provides hydraulic power for nose wheel steering, wheels braking, landing gear extension and landing gear retraction.

Hydraulic power is generated by a hydraulic package whose main components are a variable displacement pump, a reservoir, a low pressure filter and a landing gear selector valve. Two master cylinders with independent lines are provided to allow normal and emergency braking.

The hydraulic power package operates in three modes. High Duty Mode (HDM) is selected for landing gear extension and retraction. The HDM pressure range is 1,800 to 3,000 psig (124 to 207 bar). Low Duty Mode (LDM) is selected when landing gear extension has been completed and is the normal operating mode for steering and braking. The LDM pressure range is 800 to 1,200 psig (55 to 83 bar). Non Operating

Mode is selected automatically when the landing gear is retracted or the pilot has switched the power unit off.

An electrical depressurizing valve automatically selects HDM or LDM. The hydraulic system uses a hydraulic fluid according to MIL-H-5606 specification and is pressurized by bleed air.

6.5 ELECTRICAL SYSTEM

A dual parallel main bus distribution system is laid out so that, in the event of failure of a single power source or of a distribution system, power is maintained to essential equipment by the essential bus. The essential bus is energized by three paths, each equipped with one circuit breaker and one reverse current blocking diode. This ensures that the essential bus remains active with two independent faults in the feed cables.

The distribution function is ensured by a dual (internally segregated Lh and Rh side) Main Junction Box, located in the equipment section forward to the baggage volume, and by two (Pilot and Copilot side) Circuit Breakers Panel, located in the cockpit.

The new Main Junction Box provides improved reliability and enhancements on segregation and growth capacity. Two 28 Volt, 400 Ampere D.C. starter / generators

in parallel provide torque for engine starting and generate D.C. electrical power.

One 25.2 Volt, 38 Ampere-hour nickel-cadmium battery, located in the front section of the rear baggage compartment, provides power for starting and also serves as a reserve source of emergency electrical power in case of dual generator failure. A 5Ah@24VDC Emergency Power Unit is provided to supply a subset of emergency systems (Standby, COM1, ..).

Generator control units are able to maintain the output voltage of the generators at a constant level during variation in engine speed and electrical load. The electrical system is automatically protected from over-voltage and reverse current.

No AC power is required for the avionics systems. Two small dual voltage inverters, located in the cockpit, are used for powering and dimming both the electroluminescent AC panels and the incandescent DC panels/bezels.

An external power receptacle, located on the left side of the fuselage just above the main gear well and provided with overvoltage protection, allows the use of an auxiliary power source to either start the engines or perform an extended ground check of the electrical equipment.

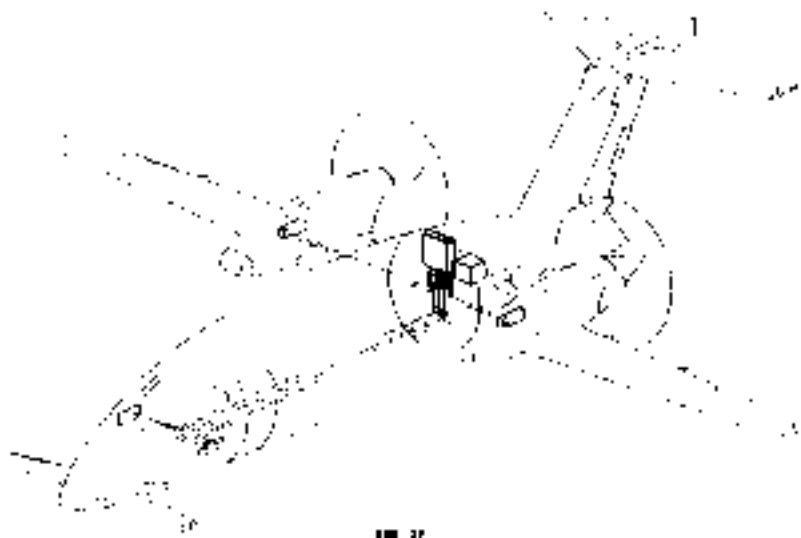

DC power distribution

6.6 LIGHTS

The aircraft is equipped with the following lights:

- two winglet (red and green, forward facing) position lights, one vertical fin top fairing (white, rear facing) position light ;
- two anti-collision strobe lights (one on top of the vertical fin and one on the bottom fuselage);
- two landing lights (one each on the legs of the main landing gear) and one taxi light (on the nose landing gear leg);
- one wing inspection light on the left outboard nacelle surface;
- one recognition/approach light located on the top of the vertical fin leading edge.

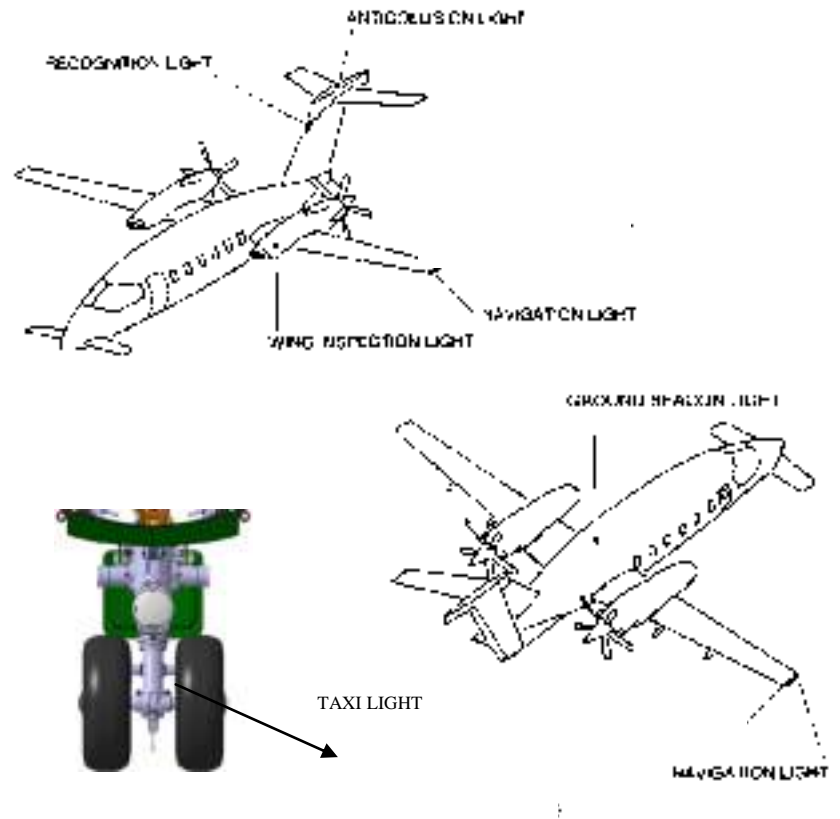

External Lights

6.7 PRESSURIZATION AND ENVIRONMENTAL SYSTEM

The environmental control system utilizes engine bleed air for heating, cooling, and pressurizing the cabin; one engine is capable of sustaining the operation of the entire system. Two outflow valves located on the rear pressure bulkhead regulate cabin pressurization. The pressurization controller provides both an auto-schedule mode and a manual control.

The 9.0 psi (.62 bar) system provides a 6,600 feet (2012 m) cabin altitude at 41,000 feet (12500 m) and maintains a sea-level cabin up to 24,000 feet (7315 m).

The new Environmental Control System provides a fully automatic, dual zone, integrated bleed air heating and vapor cycle cooling system (VCCS) ECS controller; it will automatically and independently manage the cabin and cockpit temperatures in both cooling and heating modes with an increase in cooling power of about 25%.

The integrated Environmental Control Unit is packaged to fit into the area below the P.180 baggage compartment.

Bleed air from the engine first enters a pre-cooler which reduces the temperature to an adequate level, then through a shut-off valve, a check valve and a pressure regulator reaches the ECS Gate valve.

The bleed air is divided into two flows; one enters the air to the air heat exchangers to produce a colder flow; the other one is by-

passed and then mixed to the colder flow through the two mixing valves.

The already mixed airflow is provided to passenger cabin and cockpit through two separated check valves.

The airflow is distributed in the passenger area through overhead and floor diffusers, and in the cockpit area through adjustable outlets, lateral and floor diffusers.

The controller is primarily managed by a dedicated ECS Control Panel, installed in the cockpit on pilots side instrument panel, providing both full Auto and Manual control possibility.

In the passenger cabin, a RH and a LH LCD control panels, used in conjunction with RH and LH cabin evaporator, will provide advanced control to obtain different outlet temperatures between the left outlets and the right outlets and give the passengers a semi-zone control within the limits of the cabin zone set-points.

Manual modes are also provided to allow manual control of mixing valves position, evaporator blower speeds and air-conditioning compressor operation.

The controller and cockpit control panel will also be designed to ensure adequate manual control in the event of a controller logic failure.

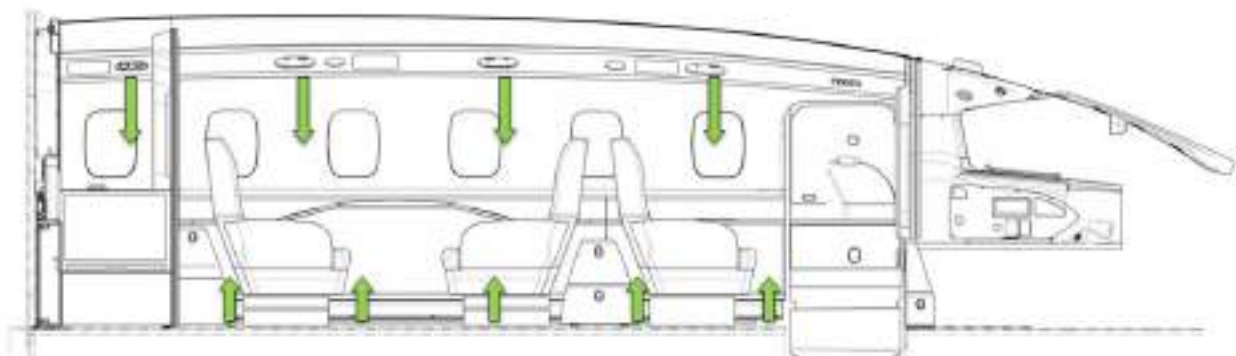

6.8 OXYGEN SYSTEM

A 40 cubic feet (1.13 m³) storage cylinder is installed on the left side of the fuselage under the cabin floor aft of the cabin door. Oxygen is supplied to pilot and co-pilot positions through quick-donning diluter/demand masks. Automatic drop-out, constant flow oxygen masks are provided at each passenger position.

6.9 ICE PROTECTION

An ice detector probe is located on the right side of the aeroplane nose. When a 0.5 millimeter thickness of ice accumulates on the probe, an amber ice caution light is illuminated on the instrument panel. A visual ice accretion probe, located adjacent to the pilot's windshield, is provided as a back-up to the ice detector. A wing inspection light is installed on the outboard side of the left engine nacelle to allow the pilot to check icing conditions during night

flight.

Main wing leading edge anti-ice is accomplished by directing engine bleed air through a diffuser duct installed in the main wing leading edge.

The forward wing contains an electrically-activated de-icing blanket on the aluminum alloy leading edge.

Nacelle inlets are de-iced by pneumatic boots. To avoid ice ingestion, an inertial separator is installed inside each nacelle. Moreover, the cycling of the nacelle boots is automatically controlled by the Ice Detector System in its primary mode of operation. A timer is provided to cycle the boots for secondary operations.

Electric heating of the windshield on both pilot and co-pilot sides is used to guard against or alleviate icing and fogging.

No ice protection is provided or required on the horizontal and the vertical tail.

7 INSTRUMENTATION AND AVIONICS

7.1 GENERAL

The cockpit layout of the Standard Configuration includes two complete crew stations equipped with dual controls, including control columns, adjustable rudder pedals and brakes. Crew seats are fully adjustable and include four-point restraint harness. An emergency oxygen system provides two diluter/demand masks for the crew members.

Cockpit lighting includes dome LED lights, instrument panel flood lights, internally-lighted instruments and dual map lights.

Two heated Pitot tubes and two heated static ports (each one with two independent sources) provide dynamic/static pressure to flight instruments.

Independent sources are used to drive the pilot's and co-pilot's flight instruments.

7.2 ELECTRONIC FLIGHT DISPLAYS

The Rockwell-Collins Pro Line 21 Electronic Flight Instrument System (EFIS) is an integrated system able to gather, concentrate, and display aircraft information to the flight crew.

The EFIS includes the following units:

- Three 8"x10" colour Liquid Crystal Adaptive Flight Displays (AFD) with LED backlight
- Two Display Control Panels (DCP)
- One Cursor Control Panel (CCP)
- An Integrated Avionics Processor System (IAPS)
- Four Data Concentrator Units (DCU)

Three AFDs with identical shape are arranged on the instrument panel as shown in Figures at pages 40 and 41. Under normal conditions the two lateral displays are configured as Primary Flight Displays (PFD) and the central display, Ethernet capable, is

configured as a Multi-Function Display (MFD) shared by the pilots.

Each PFD provides attitude, heading, airspeed, altitude, vertical speed, Flight Control System (FCS) annunciation, and navigation data on a single, integrated display.

The PFDs also display Engine Indication System (EIS) information if selected in reversionary mode. EIS information is always displayed on the MFD.

The PFDs can display a full Compass Rose, a partial Compass Arc, or a flat Compass Tape immediately beneath the attitude ball. Current heading is read opposite the lubber line. This display incorporates a pilot controllable Selected Heading Bug. The heading bug is controlled by the HDG rotary knob on the Flight Guidance Panel (FGP).

The PFDs also provide a Track Pointer, wind data, lateral navigation course and deviation data, distance data, Marker Beacon information, ILS information, vertical deviation data, VNAV deviation data, radio altitude, Decision Height and Minimum Descent Altitude, map display and a Flight Management System (FMS) Message Window.

7.3 MULTI-FUNCTION DISPLAY (MFD)

The MFD includes three major display areas: the Engine Indication System (EIS) region and the upper and lower Multi-Function Windows (MFW) below it. The EIS region is displayed across the upper portion of the MFD. The area below the engine instruments is divided into upper and lower format windows. The contents of both format windows can be separately controlled by the pilot.

The EIS area continuously shows engine parameters. The engine display format consists of a full time window showing: ITT and Torque, both in digital form and on a shared analogue gauge (one for each engine), Propeller RPM and NG, both in digital form and on individual smaller analogue gauges (one for each engine).

Digital only displays for Fuel Flow, Fuel Quantity, Oil Pressure and Oil Temperature are located on the right part of the EIS window. There are two independent sources for the primary engine parameters (ITT, Torque, NG and Prop RPM) for each engine: one is the Data Concentrator Unit (DCU) and the other is the Engine Data Concentrator (EDC). The DCU is normally the source of all displayed engine data and the EDC is a secondary source of all displayed engine data.

The Upper MFW can display either a Checklist or a FMS Text Window.

The Lower MFW can show either a compass rose, a compass arc, a present position map (PPOS), a plan map, TCAS only information (with option installed), the Systems Page, Enhanced Maps (optional; over the PPOS or Plan Map) or Graphical Weather data (optional). The turbulence radar images are displayed on the arc or PPOS data

The Upper MFW and Lower MFW can be merged into a Full Format window showing either the FMS remote text, the Status menu (including Database effectiveness, Charts Subscription, Maintenance Main Menu, FCS Diagnostic, optional File Server

configuration), Electronic Charts (optional) or video display (optional).

The ProLine 21 system may include an optional File Server Unit (FSU) providing electronic charts, enhanced map features (e.g., rivers, lakes, geopolitical boundaries, airspaces and airways) and uplinked graphical weather. The FSU is connected to the Ethernet-capable MFD providing a control interface to these enhanced features using the Cursor Control Panel (CCP); both Ethernet capable MFD and CCP are installed as standard features. Further information is provided in the Options section of this document.

7.4 RADIO SENSOR SYSTEM

The Radio Sensor System (RSS) is made up of a single CDU-3000 display unit and a single RTU-4200 tuning unit providing a primary LCD-based integrated display system for communication and navigation operations within the Air Traffic Control environment.

The basic communication system includes two VHF-4000 Communication Transceivers, two TDR-94D ATC Enhanced Mode-S Diversity Transponders, one DME-4000 transceiver (a second receiver is optional), one NAV-4000 VOR/ILS/MKR/ADF receiver and one NAV-4500 VOR/ILS/MKR Receiver.

7.5 FLIGHT MANAGEMENT SYSTEM

The FMS-3000 satellite-based navigation system provides the capability to perform en route, terminal, and non-precision approach lateral navigation with provision for LPV approaches upgrade (optional). The system contains an advanced GPS-4000S Global Positioning System SBAS (Satellite Based Augmentation System) receiver which processes the transmissions from multiple GPS satellites simultaneously to calculate navigation solutions based on information from all satellites in view.

The Attitude Heading Reference System

(AHRS), Air Data Computer (ADC), DME and VOR data are also used by the FMS. The FMS provides necessary controls for all input sensors, if appropriate.

A Coupled VNAV interface with the FCS allows the FMS VNAV function to select various FCS vertical modes of navigation. The FMS interfaces with the Data Base Unit (DBU) to update, through a USB drive, its internal Data Base and with the EFIS Displays to provide conventional navigation information and state-of-the-art map presentation.

7.6 WEATHER RADAR SYSTEM

The Rockwell-Collins RTA-852 Turbulence Detection Radar is a stabilized, solid state, X-band color radar system. The weather and map information can be overlaid on either or both PFDs and MFDs on most of the navigation display formats.

The Control Panels provide the radar mode menu selection, range select knob, tilt knob and ground clutter suppression button. With two PFDs operational, each display is controlled separately by its own Display Control Panel (DCP) and updated on alternate antenna sweeps.

7.7 FLIGHT CONTROL SYSTEM

The fail safe Flight Control System (FCS) is made up of a dual Flight Guidance System and of a 3 axis Autopilot, including Yaw Damper and Pitch Trim control.

The pilot selects the Flight Guidance Computer (FGC) in control with the Flight Guidance Panel's (FGP) coupling (CPL) switch.

Each PFD displays the Flight Director (FD) commands from the Flight Guidance Computer selected with the CPL switch, except for Go Around (GA) and Approach (APPR) modes. The GA and APPR modes are Independent Modes, and only the on-side Flight Guidance Computer guidance is used by the associated PFD for Independent Modes.

7.8 STAND-BY INSTRUMENTS

An L-3 Communication integrated stand-by instrument located on the top of the centre instrument panel and supplied by an emergency battery provides essential flight parameters in case of loss of primary sensors or displays.

7.9 ELT

An Artex C406 3-frequency Emergency Locator Transmitter transmits on the two Emergency Frequencies of 121.5 and 243.0 MHz as well as on the satellite frequency of 406.025 MHz.

The system is activated either automatically by a g-switch or by the crew through a switch located in the cockpit.

7.10 INTEGRATED FLIGHT INFORMATION SYSTEM (IFIS)

The IFIS provides capability to display maps (airways, airspace boundaries, geopolitical data), Jeppesen charts (airport charts, approach charts, en-route charts) or weather graphical information on the Multi Function Display. It includes the following:

- Rockwell-Collins FSU-5010 File Server Unit (FSU)
- Rockwell-Collins FSA-5000 File Server Application software
- Rockwell-Collins ECU-3000 External Compensation Unit

7.11 ELECTRONIC CHARTS FOR IFIS

Jeppesen charts (airport charts, SID and STAR charts, Instrument procedure charts, en-route charts) Rockwell-Collins ECH-5000 are installed on the FSU for visualization in the Multi Function Display.

The Chart image files are stored in the FSU and are selected for display via the Chart Main Menu. The Cursor Control Panel provides an interface with the Chart Main Menu and is also used to manipulate the displayed chart. The chart feature also provides a depiction of the aircraft's current

position on all charts that have been geographically referenced.

It requires subscription to the Jeppesen Charts Update Service.

7.12 ENHANCED MAP OVERLAY FOR IFIS

It provides the capability to display geopolitical data, airways and airspace maps on the Multi Function Display. It includes the installation of the following additional software:

- Rockwell-Collins OVL-5000 Enhanced Map Overlays

Map displays are controlled via the Cursor Control Panel or via line select keys to access the Map Menu. In order to prevent display clutter, each of the enhanced map overlays is automatically removed as map range is increased. The airways and airspace depictions are removed when range is increased over 100nm. The geopolitical map data is removed when map range is increased over 300nm. It requires subscription to the Rockwell-Collins Map Service.

7.13 TCAS I

An L-3 Communications Skywatch HP model SKY899 TCAS I airborne Traffic Alert and Collision Avoidance System (optional kit) is provided as standard equipment. The TCAS I system interrogates ATC transponders in nearby aircraft and uses computer processing to identify and display potential and predicted collision threats along with an aural warning when requested. TCAS I traffic information can be selected for pictorial display on the PFD and/or the MFD to indicate the presence of other aircraft within a selected range around the aircraft.

7.14 TAWS

An L-3 Communications Landmark Class-B model TAWS 8000 Terrain Awareness and Warning System (optional kit) is provided as standard equipment.

The system provides traditional Ground

Proximity Warning System (GPWS) functionality to prevent Controlled Flight Into Terrain, enhanced by a stored worldwide database including terrain, airport and obstacle data. TAWS provides the pilot with predictive warnings based on comparison between stored obstacle data and a prediction of the aircraft's flight path derived from FMS and GPS data and current flight parameters. TAWS provides aural and visual warnings to alert the pilot in case a hazardous condition is detected and includes the possibility to represent terrain elevation features on the AFDs graphically.

7.15 IRIDIUM SATELLITE PHONE

An AirCell ST3100 Iridium Satcom system (optional kit), installed as standard equipment provides worldwide access to the Iridium global satellite network. It includes:

- An ST3100 transceiver unit located in the passenger cabin and a patch antenna located on the top fuselage
- A cordless base station located on the top of the forward right hand side partition cabinet in the passenger cabin, in position also accessible from the cockpit.
- A cordless handset providing voice communications, control functions and programming
- Two RS232 data ports in the passenger cabin for data (fax/email) transfer through the Iridium Satellite phone network.

7.16 ADDITIONAL FEATURES

The standard ProLine 21 avionics system of the P.180 provides the capability to operate in RVSM-airspace and to perform Category II approaches and steep approaches.

The flight envelope extension to Mach 0.7 Mmo is also a standard feature.

7.17 PROVISIONS

7.17.1 PROVISION FOR XM/WSI SATELLITE SYSTEM RECEPTION

Structural and electrical provisions for XM/WSI Satellite Weather Graphical Information functionality. The provision includes XM antenna, Wiring harness, Structural provision for XM weather receiver.

7.17.2 AUXILIARY CABIN POWER KIT

This kit provides two sockets (40Amps max @28VDC) under cabin compartment floor, to provide electrical power either to sanitary or other equipment (if approved). The power is provided both on ground or in flight (at least one generator is properly operating and set on line).

8 STANDARD AIRCRAFT CONFIGURATION

8.1 AVIONICS, INSTRUMENTS AND CONTROL PANEL

- Radio Management System – Rockwell-Collins RTU-4200, CDU-3000
- Dual VHF COM - Rockwell-Collins VHF-4000 Transceiver with Antenna with 8.33 kHz spacing
- VHF NAV1+ADF - Rockwell-Collins NAV-4000 VOR/ILS/MKR/ADF Receiver with Antennae
- VHF NAV 2 - Rockwell-Collins NAV-4500 VOR/ILS/MKR Receiver with Antennae
- Single DME - Rockwell-Collins DME-4000 (3 channel) with Antenna
- Dual Mode S Flight ID Diversity Transponder - Rockwell-Collins TDR-94D
- Radio Altimeter - Rockwell-Collins ALT-4000 (Operation to 2500 ft) with Antennae
- Turbulence Detection Weather Radar - Rockwell-Collins RTA-852 Color Radar with 12" Antenna
- Dual Audio Panel - Baker B1045
- Dual Cockpit Speaker
- Dual hand-held Microphone
- Dual Boom/Microphone/Headset – Telex 850 ANR
- EFIS with EIS – Two Rockwell-Collins displays AFD-3010 with two DCP-3030,
One Rockwell-Collins display AFD-3010E with CCP-3000
- Flight Guidance System - Rockwell-Collins Dual FGC-3003 (A/P,YD and dual Flight Director included), three SVO-3000 Servos, single FGP-3000 Flight Guidance Panel
- Single FMS - Rockwell-Collins FMC-3000 (NAV to NAV and VNAV), CDU-3000 (used also for radio tuning), DBU-5000
- GPS Sensor Unit - Rockwell-Collins GPS-4000S
- Dual ADS - Rockwell-Collins ADC-3000
- Dual AHRS - Rockwell-Collins AHC-3000 and FDU-3000
- Maintenance Diagnostic System - Rockwell-Collins MDC-3110
- Four Data Concentrator Unit - Rockwell-Collins DCU-3001
- Stand-by Cluster Instrument – L-3 Communications GH-3100
- Emergency Locator Transmitter – Artex C406 (3 frequency)
- Dual Digital Clock (Chronometer included)
- Dual Master Annunciator
- Dual Turn&Slip Indicator (shown on the displays)
- Reversionary/Miscellaneous Panel
- Hobbs meter
- Integrated Flight Information System (IFIS) including:
 - Rockwell-Collins FSU-5010 File Server Unit (FSU)
 - Rockwell-Collins FSA-5000 File Server Application software
 - Rockwell-Collins ECU-3000 External Compensation Unit
- Rockwell-Collins ECH-5000 Electronic Charts installation in the FSU
- Rockwell-Collins OVL-5000 Enhanced Map Overlays installation
- TCAS I – L-3 Communications SkyWatch HP model SKY899
- TAWS Class B with Worldwide Database – L-3 Communications Landmark model TAWS8000
- AirCell ST3100 Iridium Satcom

NOTE: RVSM, Mach 0.7, Category II Landings and Steep Approach capabilities are included as standard.

8.2 ELECTRICAL SYSTEMS AND LIGHTS

- Two 400A, 28V Starter Generators
- Two Solid State Generator Control Unit
- Nickel-Cadmium Battery (38 Ah)
- Emergency Power Unit (5Ah)
- External Power Receptacle with Overvoltage Protection
- Main Junction Box with self test (rear non pressurized volume)
- Two Circuit Breakers Panels (Lh & Rh side cockpit) providing nine busses DC Distribution System with Auto Load Sharing
- Dual Solid State Master Warning and Caution Panels with Self Test
- Solid State Warning and Caution Annunciator Panel with Self Test and Dimmer System
- Pitot Heating Monitor
- Static Wicks
- Heated Stall Warning System with Pre-flight Self Test System
- One LED Taxi and two LED Landing Lights
- Two LED Left & Right Position Lights (red & green on each winglet leading edge)
- One LED Rear Position Light (white, rear facing on vertical fin top fairing)
- LED Anti-Collision Strobe System (top and bottom)
- LED Recognition Light (On top of Vertical Fin)
- LED Wing Ice Inspection Light
- Cockpit Dome Lights
- Flood Lights
- Instrument Lighting System
- Dual Map Lights in Cockpit Area
- Cabin Floor LED lighting
- LED lighting in the passenger cabin and in the toilet area
- Two 28 VDC Auxiliary Cabin Power Outlets (underneath the cabin floor).
- 110 VAC power outlets in cockpit (Qty. 2) and passenger cabin (Qty. 4)
- Two RS232 data ports in the passenger cabin for data (fax/email) transfer capabilities through the **Iridium Satellite** phone network only.

8.3 POWERPLANT AND RELATED SYSTEMS

- Two PRATT & WHITNEY model PT6A-66B Free Turbine Engines flat rated at 850 Shaft Horse Power and Engine Accessories, equipped with Torque Limiter
- Two HARTZELL HC-E5N 86,5" diameter, five metal blades, scimitar type, fully feathering and reversible, hydraulically controlled, constant speed propellers
- Magnetic Chip Detector
- Oil Quantity Dipstick Indicator
- Primary Propeller Governor
- Overspeed Propeller Governor
- N1 and N2 Magnetic Pick-up Speed Sensors
- Two Power Levers for Forward and Reverse Power
- Two Condition Levers for Propeller speed, High/Low Idle, Feather and Engine Cut-off
- Auto Ignition System
- Submerged electric main and standby Fuel Boost Pumps
- Fuel Control Unit
- Fuel Heater System
- Fuel Crossfeed System
- Low Fuel Quantity Warning System

- Two Fuel Quantity Indicators (on the Multi Function Display)
- Two Fuel Flow Indicators (on the Multi Function Display)
- Fuel Drain System
- Fuel Tank Interconnect
- Pressure and Gravity Refueling
- Low Oil Quantity Warning System
- Propellers Auto-feather
- Complete Engine Anti-Icing System with Ice Protected Engine Inlet
- Engine Parameter Indication on Multi Function Display
- Engine Fire Detection System
- Engine Fire Extinguishing System

8.4 SYSTEMS

- Oxygen System for Pilots (Two Diluter / Demand Masks) and Passengers (Ten Masks)
- Digital Cabin Pressure Control System with manual back-up
- Mixed Air Environmental Control System with Freon cooling system
- Forward Wing Anti-Ice System (Electrical)
- Main Wing Anti-Ice System (bleed air)
- Windshield Electrical Anti-Ice and Defogging
- Hydraulic Power Pack
- Dual heated Pitot and Static Ports with heating monitor
- Alternate Heated Static Source
- Propeller Synchrophaser
- Steerable Dual Wheel Nose Landing Gear – MAGNAGHI
 - Electro-Hydraulic Class B Steering, full time use - EATON
- Single Wheel Main Landing Gear - MAGNAGHI
- Main Wheel and Tires (6.50 - 10) - GOODRICH
- Nose Wheels and Tires (5.00 - 5) - GOODRICH
- Carbon Brakes on each Main Wheel
- Landing Gear Position Lights, Down and Locked
- Landing Gear Warning Horn and In-Transit Light
- Dual Conventional 3-Axis Aircraft Control System
- Dual Adjustable Rudder Pedals and Toe-Operated Brakes
- Parking Brake
- Emergency Landing Gear Extension System (Hand Pump)
- Electric Aileron Trim Tab (Roll)
- Electric Rudder Trim Tab (Yaw)
- Electric Stabiliser Trim Actuator (Pitch)
- Electric Flap System with Electronic Control Unit and Four Motors

8.5 EMERGENCY EQUIPMENT

- Portable fire extinguisher
- Crew and passenger oxygen
- Emergency flashlight
- First Aid kit provision

8.6 MISCELLANEOUS AND GROUND SUPPORT EQUIPMENT

- Cabin baggage straps

- Pitot covers
- TAT sensor cap
- Anti-ice detector cap
- Engine intake blanks
- Oil cooler inlet blanks
- Starter generator and inertial separator blanks
- Air conditioning scoop cap
- Engine stack caps
- AOA transducer cap
- Static wick covers
- Telescoping tow bar
- Jack pads
- Lifting brackets
- Mooring pads with rings
- Wheel chocks
- Gust locks
- Propeller restrainers
- Fuel drain tool
- Tool case
- Windshield sun shades
- Access panel for air conditioning service
- Cockpit pedestal guard
- Cockpit glare shield check list holder
- Cockpit seat shoulder belt guide plate assembly
- Cockpit lower sidewall panels
- Cockpit control column leather boots
- Cockpit glare shield
- Cockpit seats
- Baggage compartment finishing
- Baggage compartment protective flap

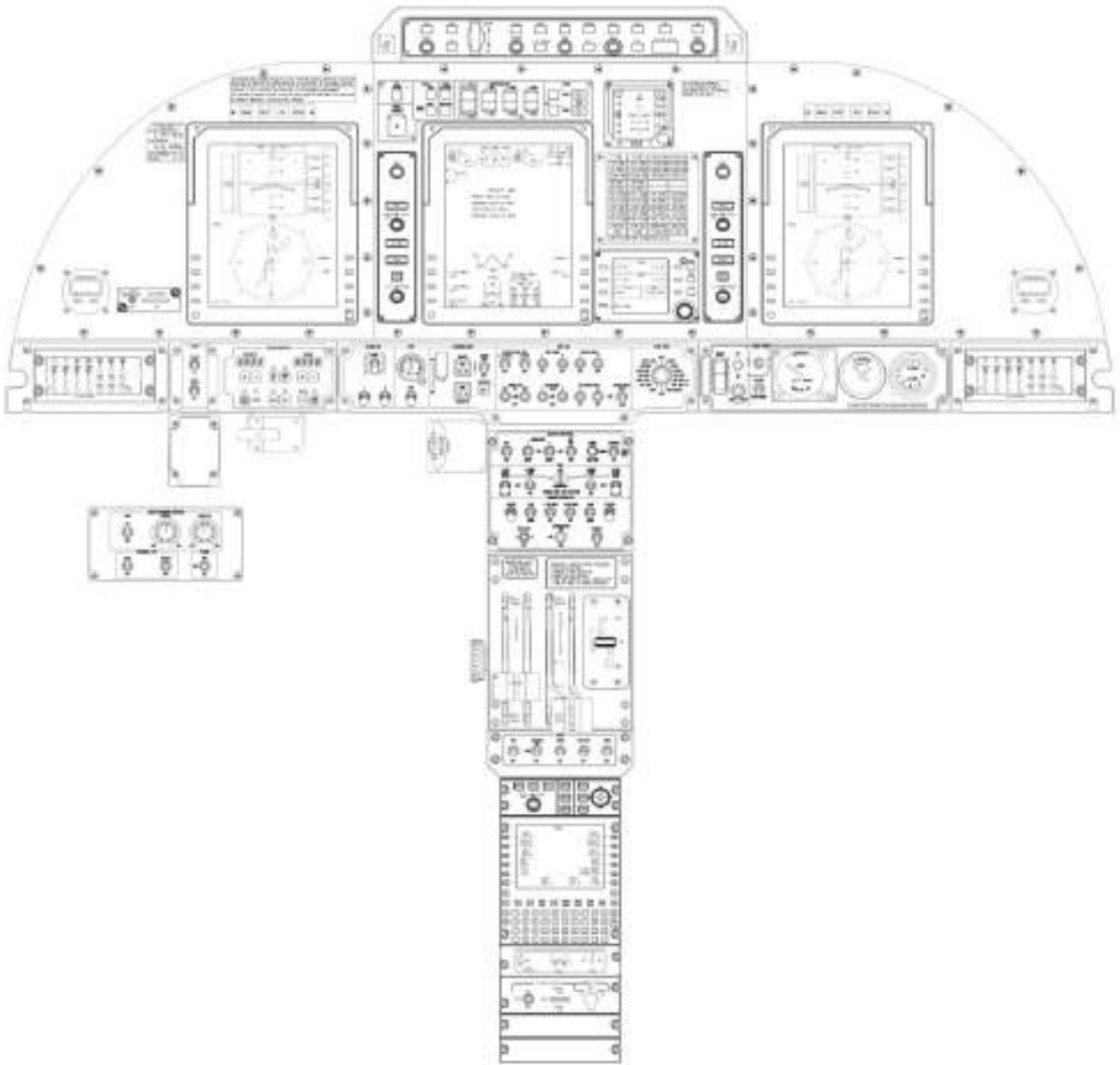

Standard Instrument Panel

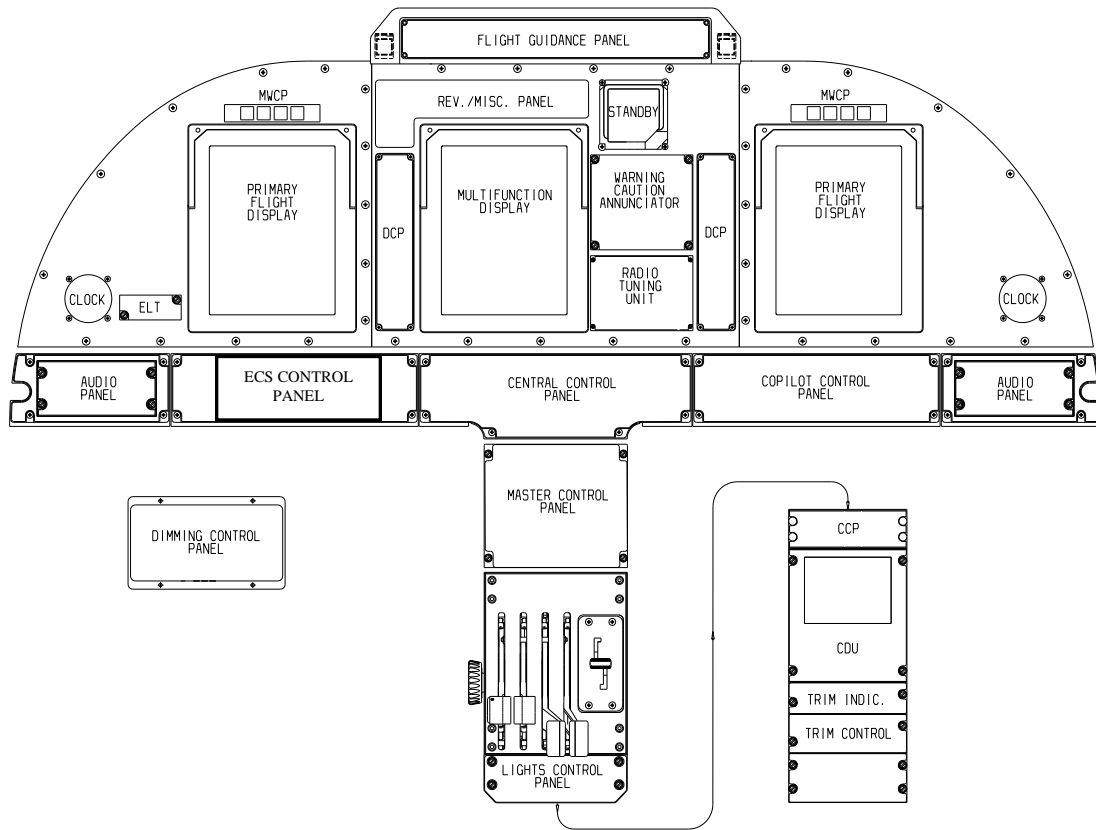

Standard Instrument Panel

9 OPTIONAL EQUIPMENT

9.1 INCREASED RANGE OPTION

This option will provide the installation of an additional fuel tank providing a usable fuel capacity of about 58 U.S. gallons (390lbs, 220litres); the tank is divided in two separated parts (29 US Gallons, 195lbs, 110litres each) interconnected respectively to baseline left and right side fuel systems; each part is equipped with a dedicated probe interfaced with aircraft fuel quantity measurement system.

As before mentioned, the total usable fuel system capacity with the additional fuel tank will become 476 U.S. gallons (3,218 lbs, 1,802litres).

Refueling and fuel unload operations remain unchanged.

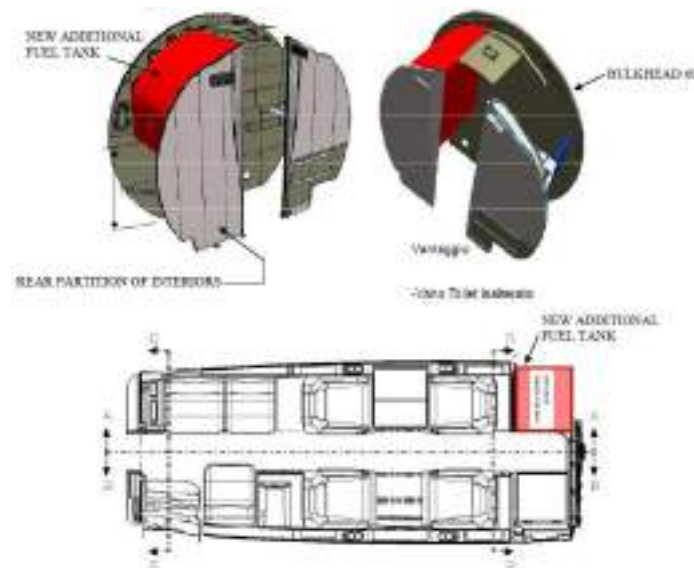

9.2 AVIONICS OPTIONS

9.2.1 “ENHANCED SAFETY OF FLIGHT PACKAGE”: ACAS II + EGPWS (TAWS CLASS A)

Rockwell Collins TCAS 4000 and Honeywell EGPWS Mark VIII replacing standard TCAS I L-3 SKY 899 and TAWS B BF Goodrich Landmark 8000.

9.2.2 ACAS II 7.1

The Rockwell Collins TCAS-4000 (compliant with ICAO ACAS II Change 7 requirements) improves safety with total situational awareness of impending traffic conflicts, including the display of revolutionary information for immediate threats.

The system tracks all Mode C and Mode S transponders within 35nm and provides range, relative bearing and altitude information for the up to 30 aircraft that representing the highest

collision threat.

Traffic Alerts (TAs) and Resolution Advisories (RAs) are given aurally through the aircraft audio system and visually on the PFDs.

When other TCAS II-equipped aircraft are encountered, complementary RA maneuvers are coordinated by each system.

Resolution Advisory commands appear on the two vertical speed indicators or the vertical speed display fields of integrated electronic flight display systems.

NOTE: If requested ACAS II system can be installed also in conjunction with TAWS Class B.

9.2.3 EGPWS

The MK VIII version of Honeywell's EGPWS is a Class A TAWS that helps to prevent accidents caused by Controlled Flight into Terrain (CFIT).

The system achieves this by using a number of aircraft inputs, applying proprietary alerting algorithms, and alerting the crew with aural messages, visual indications, and a display of terrain in the event the boundaries of the alerting envelope have been exceeded.

System configuration is controlled via a programmable module. The MK VIII offers a worldwide terrain database. Databases are loaded via a convenient ATA format PCMCIA card using Honeywell's SmartCable interface.

*Note: EGPWS installation is **incompatible** with SBAS LPV (§ 9.2.13) option.*

9.2.4 HF WIRING PROVISIONS

It provides wiring and mounting provisions for later installation of the HF system.

9.2.5 HF RADIO SYSTEM

The Rockwell Collins HF 9000 Radio Communication System can be added to the two VHF Communication Systems to perform long-distance voice communications. High Frequency radio communications allow reliable long range transmission and reception over distances of thousands of miles. This makes HF radio particularly useful when flying over vast surfaces where VHF communications, limited to line of sight transmission, are out of reach.

9.2.6 INMARSAT SATELLITE PHONE

A Thrane & Thrane Aviator 200 Inmarsat Satcom system can be installed in alternative to above Aircell ST3100 Iridium Satcom one.

The Aviator 200 using Inmarsat's SwiftBroadband (SB) services can provide an IP connection to ground with a maximum bandwidth of 200 kbit/s to allow, virtually anywhere in the world, a wide range of in-flight capability including E-mail, Internet Browsing, Smart Phone Connectivity and Voice Services; it offers also a Built-in wireless connection.

The Aviator 200 Swiftbroadband system includes:

- A SwiftBroadband Unit (SBU) located in the passenger cabin with a configuration module holding the SIM card
- A low gain antenna located on the top fuselage with a HLD unit (High Power Amplifier, Low Noise Amplifier and Diplexer in one unit).
- A wired handset/cradle located on the top of the forward right hand side partition cabinet in the passenger cabin, in position also accessible from the cockpit.

- A wireless handset/cradle located on the top of the aft left hand side cabinet in the passenger cabin

*Note: Aviator 200 installation is **not feasible** with current ADASd/DTU kit installation (same location)*

9.2.7 PROVISION FOR IPAD MINI AS EFB

This optional provision shall install the means needed for the operation of two Apple iPad mini (not part of the kit) as optional Class 2 / Type B Electronic Flight Bags (EFB).

The kit will add, on both pilot and co-pilot side, a device mounting mean in place of the control wheel map holder and a dedicated power supply socket.

9.2.8 FULL PROVISION FOR CVR INSTALLATION

Structural and electrical provisions (wiring and connections) for the L-3 Communications FA2100 Cockpit Voice Recorder.

9.2.9 COCKPIT VOICE RECORDER

The L-3 Communications FA2100 Cockpit Voice Recorder allows recording of all audio signals:

- signals transmitted or received by the pilot and the co-pilot,
- cabin page announcements,
- cockpit conversations, through the cockpit area microphone

All audio inputs are fed into 120-minutes recording channels. The FA2100 is provided with an Underwater Locator Beacon (ULB) and a g-switch enables to stop the record in case of impact.

The kit includes:

- A CVR recording unit located in the baggage compartment
- A CVR control unit located in the pedestal
- A g-switch located in the vanity area close to the aircraft C.G.
- A cockpit microphone located on the pedestal top on the RH side

The CVR is mandatory in the US and Canada for aircraft equipped with 6 or more passenger seats operating under FAR 135.

9.2.10 COCKPIT VOICE RECORDER PORTABLE INTERFACE UNIT

The L-3 Communications Cockpit Voice Recorder Portable Interface Unit allows the download of recorded data as well as maintenance and operational checks on the FA2100 Cockpit Voice Recorder unit. During normal operations, it is not usually carried on board of the aircraft.

The Portable Interface unit is fully interchangeable and can be used in connection with any L-3 Communications FA2100 Cockpit Voice Recorder unit.

9.2.11 COCKPIT VOICE AND DATA RECORDER COMBO UNIT (CVDR)

In lieu of above Cockpit Voice Recorder a L-3 FA2100 Solid-State Cockpit Voice and Data Recorder (CVDR) can be installed, integrating CVR and FDR in a Combo Unit.

FA2100 CVDR provides four channel, 2 hour or 30 minute high quality audio recording and 64/128/256/512 words per second flight data for a minimum of 25 hours recording of Air Data, Acceleration, Attitude, AoA, flaps position, Engines Power & Prop Reverse Condition, Radio Transmission Keying, A/P Modes and Engagement Status, Selected Altitude, Speed, Mach, Heading, Display Format.

9.2.12 LIGHTNING DETECTION SYSTEM (STORMSCOPE)

It provides a L-3 Communications WX-1000E Stormscope lightning detection system able to detect various levels of lightning activity and to process that information into ARINC 429 format to be displayed on the AFDs.

Lightning detection is generally limited to approximately 200 NM from the aircraft. Lightning data from the lightning detection system may be superimposed with weather radar data on those PFD and MFD formats which are weather radar compatible.

9.2.13 SATELLITE BASED AUGMENTATION SYSTEM - SBAS LPV

This option provides the Localizer Performance with Vertical Guidance (LPV) approach capability to the P.180 Avanti EVO Flight Management System.

LPV (Localizer Performance with Vertical guidance) is a type of approach procedure where both the lateral and the vertical profile guidance is computed upon SBAS augmented GPS signals.

LPV enables descent to 200-250 feet above the runway, and can only be flown with a SBAS receiver under WAAS / EGNOS / MSAS signal coverage; the embodiment of this modification enables full IFR precision approach availability even at small airports.

The Temperature Compensation enhances the performances of APV-Baro (Approach Procedure with Barometric Vertical guidance) approach procedures that can be safely flown even below the prescribed cold temperature limit.

*Note: SBAS LPV option installation is **incompatible** with EGPWS (§9.2.3) option.*

9.2.14 VIDEO CAPABILITY FOR THE MFD

The Rockwell Collins VID-3000 option allow to receive on the MFD video signals from Cameras and or other video systems.

9.2.15 ENGINE DATA - ACQUISITION AND MONITORING SYSTEM ADASd

The ADAS (Aircraft Data Acquisition System - digital) manufactured by P&WC/Altair provides optional maintenance information, enabling the operator to control, qualify and manage engine maintenance operations. Recorded engine data can be downloaded and then uploaded to Altair TurbineTracker™ web service, an Internet-based data management system software for remote engine data management, to track the usage and the engine performance trend in real-time.

The system performs the following primary functions:

- Exceedance Events Recording
- Engine Trend Monitoring
- Built-in Test Capability (Trend/Fault Illuminated Pushbutton)

The ADAS system main components are:

- System Processor Unit (provided with a dedicated mount),
- Trend Switch/Fault illuminated pushbutton (on the instrument panel),
- Serial connection for data upload/download with Monitor Link Program.

*Note: ADASd installation is **not feasible** with Aviator 200 installation (same location)*

9.2.16 ENGINE DATA – TRANSFER UNIT DTU

In conjunction with ADAS (Aircraft Data Acquisition System), the Data Transmission Unit (DTU) provides the communication capabilities through which the engine performance data can stream to the maintenance organization without pilot/operator intervention. This equipment

requires the installation of the ADAS, as the source of data.

On landing, the DTU automatically collects data from the ADAS and establishes a cellular connection (utilizing GSM/GPRS) with the Altair TurbineTracker™ web service, an Internet based data management service for review and remote engine trouble-shooting.

*Note: DTU installation is **not feasible** with Aviator 200 installation (same location)*

9.2.17 ANTISKID OPTION

Avanti EVO may install an Antiskid system on its Brake system with the main purpose to increase ground handling qualities and reduce pilot workload.

This system will provide skid control envelope from 10 to 154 kts, locked wheel protection, touch-down protection and spin-up override.

The Antiskid system control unit, depending on the wheel speeds provided by dedicated transducers installed in the MLG axles, will drive hydraulic pressure (through a dedicated Dual Skid Valve -DSV) to the brakes avoiding skidding conditions.

The system is designed to minimize installation & weight impacts.

9.3 MISCELLANEOUS EQUIPMENT

9.3.1 FIRST AID OXYGEN SYSTEM

The First Aid Oxygen System consists of an additional outlet valve connected to the pilot main oxygen line. It is placed in a convenient location in the airplane cabin, depending on the type of airplane interior configuration.

A medical oxygen mask with a metered two-flow selector provides oxygen flow at 2 lpm or at 4 lpm. It is available at any time during flight, by connecting the appropriate oxygen mask to the outlet valve.

9.3.2 PORTABLE OXYGEN CYLINDER

The portable oxygen cylinder provides a supplementary oxygen source for crew and passengers use, if requested. The oxygen cylinder is installed inside the wardrobe, located in the vanity section. It is attached to the right side of the forward wall of the wardrobe.

It supplies a constant flow of oxygen to the masks up to 16500 ft cabin altitude. The oxygen unit is provided with 2 masks, each equipped with a flow indicator.

The table below gives the average duration in hours of a cylinder fully charged to 1800 psig, with respect to the cabin altitude.

CABIN ALTITUDE (Feet)	1 passenger	2 passengers
0	2.75	1.38
12500	3.03	1.52
16500	3.13	1.57

Oxygen Cylinder Duration (hours).

Use of supplementary oxygen is allowed only when the cabin is pressurized or when the cabin altitude is below 16500 ft.

9.3.3 EU OPS 1 /FAR 135 Kit

Loose supplies for Public Transport Operators in compliance with EU OPS 1 requirement.

The kit includes:

- Protective breathing equipment (PBE) (qty 1), including an emergency escape hood for automatic oxygen flow and smoke protection for crew members
- Smoke goggles (qty 2)
- Live vests (qty. 10)
- One additional electric torch
- Templates for typical Safety Briefing Card and Equipment Location Card.

9.3.4 GRAVEL KIT

The kit is installed on the nose landing gear to protect the aircraft lower fuselage and wings from small debris that may be thrown up by the nose landing gear during operations on unpaved runways.

The kit is designed to allow operation on grass or compacted gravel runways with CBR > 15; it is not designed to allow operation on rough or unprepared strips with loose gravel.

Performance degradation for take-off and landing are defined in the relevant sections of the Flight Manual. Operation from unpaved runways implies application of a factor 4 for the purpose of calculating the operational cycles of the landing gear.

9.3.5 LEAD ACID BATTERY

Installation of a 38 Ampere hours Concorde lead Acid Battery in lieu of the standard nickel-cadmium battery.

9.3.6 NICKEL-CADMIUM BATTERY

Installation of a 43 Ampere hours SAFT Nickel Cadmium battery in lieu of the standard 38Ah Marathon nickel-cadmium battery with updated maintenance intervals.

9.3.7 PROVISION FOR PORTABLE ELT STOWAGE

This interior provision shall allow the stowage, in the cockpit, of a portable ELT (PARM-406A type, customer supplied) together with its containing box.

9.3.8 LIFE RAFT

One Winslow Life Raft, stored in the lower part of the lavatory cabinet featuring a standard capacity of 7 persons and an overload capacity of 10 people.

The life raft features twin buoyancy tubes, light weight canopy, triple frequency ELT and survival equipment in compliance with EU.OPS or FAR Part 91&121

9.3.9 14VDC AUXILIARY POWER

Installation of two sockets powered with 14VDC installed close to the left & right tables in the typical club configuration.

9.3.10 230VAC POWER OUTLETS

In lieu of baseline 110VAC power supply capability, a KGS 230 VAC@50Hz power source can be provided, with the same purpose of supplying the power outlets in cockpit (Qty. 2)

and passenger cabin (Qty. 4), intended to be used by the cabin passengers and by the flight crew for supplying portable electronic devices (PEDs) like portable computers, tablets, smartphone, etc.

Polished Leading Edge

In lieu of standard painted wing leading edge, an optional polished leading edge can be selected.

The polished leading edge is unpainted and uncoated by current traditional protective processes with the ALCLAD surface directly in view to the external environment.

9.3.11 MAXIMUM TAKE-OFF WEIGHT @ 11550LBS

If requested, the aircraft can be delivered with a Maximum Take-Off Weight (MTOW) of 11550lbs.

Dedicated labels and AFM supplement will be provided.

10 INTERIORS

10.1 GENERAL

The cabin is separated from the cockpit by dividers. The fuselage is shaped to minimize drag, while providing the maximum possible interior volume. Thus the Avanti EVO fuselage has a tapering cabin cross section, with maximum height and width achieved in the middle of the cabin.

Cabin length, including lavatory, is 14.9 feet (4.55 m), width is 73 inches (1.854 m) and height is 69 inches (1.753 m) from the 6.5 inches (165 mm) dropped aisle to the cabin ceiling.

The cabin may be configured with interior arrangements for six to nine passengers. The aircraft has an externally accessible baggage compartment of 35 cubic feet (1 m³).

The interior has been designed with a composite honeycomb constructed shell for maximum strength, durability and acoustically quiet environment. The interior has also been designed to allow individual owners to select the finished surfaces according to their own desires.

Passenger seats track fore and aft, track laterally outward from the sidewall, swivel 180 degrees, and recline. All passenger seats are equipped with a shoulder harness for take-off and landing.

Constant flow oxygen masks automatically deploy for each passenger when a sudden change in cabin pressure is detected by the cabin pressurization system.

10.2 CABIN

The P.180 Avanti EVO interiors can be configured according to four Corporate floor plan layouts (7 or 6 seats VIP style), a “shuttle” layout (7 seats airline style) or even “Special Missions” layout to be adapted for MEDEVAC, Surveillance or Flight Inspection operations.

The Corporate interior configurations

include the following:

- Four seats in a club arrangement in the rear cabin.
- Two side-facing divans or one side-facing divan and a forward-facing seat or two forward-facing seats in the forward cabin.
- A toilet seat approved for take-off and landing.
- One or more refreshment cabinets, depending on the seat configuration, containing storage areas for food and beverages, compartments for ice, soda cans and small bottles. On certain configurations, a dedicated compartment can hold hot beverages carafes or electrically heated dispensers (optional); storage space for glasses, cups, condiments and miscellaneous items is also available.
- Two folding tables located between the club seats.
- An armrest console running the length of the main cabin including dual figure drink holders and closed storage compartments for miscellaneous objects at each club seat location.
- 110 VAC power outlets (Qty. 4) located inside the storage compartment.

Passenger windows have opaque privacy shades and a reflective outer surface to reduce heat build-up on the ground.

The cabin lighting system (Corporate versions) include:

- Downwash LED lighting
- Upwash LED lighting
- Floor lighting
- Accent lighting
- Individual Reading Lights

The LED lights can be switched on and off and dimmed by conveniently located push buttons.

Ordinance signs (“Fasten Seat Belts” and “No Smoking” signs) are located on the partitions and inside the toilet compartment.

The rear part of the cabin houses a full privacy lavatory module, which can be completely closed by a sliding pocket door.

It is equipped with an electrically flushing toilet on the left hand side, featuring a Teflon bowl for ease of maintenance. It has a fully secured, removable tank for servicing.

A cosmetic mirror covers the top portion of the aft partition of the lavatory module.

The right hand toilet cabinet is provided with several different compartments which can house towels, facial tissue, soap and toilet tissue dispensers. A stainless steel waste container is provided for solid or liquid waste.

When the aircraft is equipped with Increased Range option, the upper section of the right hand cabinet is no more available. The lower section could provide a limited storage capacity if not already used for life raft housing.

A self-containing water system including a fresh water tank, a spring actuated tap, a drainable sink and a waste water tank is available as an optional.

A rear coat closet inside the lavatory module has the capacity for all passenger coats as well as brief case storage. A removable coat rod is located at the top; a removable shelf is also provided at mid-height of the cabinet to allow for a higher flexibility of use.

A removable drawer is provided at the bottom of the closet for supply storage.

10.3 CABIN NOISE

The internal cabin noise is significantly lower than in other turboprop aircraft and compares also favorably with noise of typical jet aircraft.

As a side benefit, the new propeller arrangement provides a slight improvement to the already best in class internal noise levels.

As reference, table below details the internal noise measured on the ground and in flight using a Precision Sound Level Meter in various ground and flight conditions.

Taxiing	70 dB(A)	
Take-off	81 dB(A)	
Climb	76 dB(A)	
Cruise	74 dB(A); 65 SIL (dB)	(350 KTAS, 23000 ft, 1800 rpm)

10.4 MISCELLANEOUS COCKPIT FURNISHINGS

- Two crew storage cabinets;
- Dual adjustable sun visors
- Assist handles;
- Dual cup holders;
- Two cockpit speakers;
- Cockpit dome lights (white/red);
- Instrument panel flood lights;
- Internally lighted instruments;
- Dual map lights;
- Yoke mounted chart holders;
- Portable fire extinguisher.
- Cockpit pedestal guide
- Cockpit glare shield check list holder
- Cockpit control column leather boots

10.5 INTERIOR DESCRIPTION

The available Avanti EVO interior configurations are detailed in the following including:

- Common interior trim shared by all available layout configurations,
- Five different floor plans available
- Applications other than corporate/VIP
- Interior accessories and furnishing to applicable Corporate layouts,
- Styling, colors and materials as applicable.

Interior configurations and individual element design can be changed by Piaggio Aero Industries without notice.



10.6 STANDARD PASSENGER INTERIOR TRIM

All passenger interior configurations share the following elements:

Interior liners and paneling

The Avanti EVO interior liners are manufactured using light weight composite panels that line the interior ceiling and windows, providing lighting and systems to the passengers. These panels may be covered in a variety of standard decorative fabrics, leathers and veneers. The interior paneling consist of the following components:

- Headliner
- Passenger Service Panels (PSU), featuring continuous dimmable LED lights for up wash and down wash lighting, drop-out oxygen masks at each seat location, air outlets and reading lights at each seat location, speakers)
- Window Panels, featuring manually operated pleated window shades
- Windows shades encapsulated between two transparent sheets
- Side ledge and Dado panels, featuring club tables, dual drink holders, light switches and storage compartments with standard universal electrical outlets and optional data port

Forward partitions and cabinetry

The flight deck is separated from the cabin seating area by two partitions and a pair of cabinets which act as a divider and provide storage for passengers and crew.

The Left and Right Hand partitions consist of the following features:

Left Hand Forward Partition

- Entry Assist Hand Rail
- Entry Switch Panel (Entry, Cabin and Crew Lights)
- Entry Light
- Advisory Lighted Sign (No Smoking / Fasten Seatbelts)
- Drawer for fire extinguisher
- Chart stowage provisions (flight deck side)
- (FMS) Flight Management System Data Loader

Right Hand Forward Partition

- Upper Storage Drawer for airplane flight manuals and Jeppesen manuals
- Lower Storage Drawer for miscellaneous storage or smoke hood storage compartment
- Aircell Satellite Phone
- Dual drink holder and Switch Panel (Read Light)

An annex cabinet (to be installed just aft) is available as an option for the Corporate 2 to provide further refreshment stowage.

Aft Partition and Sliding Door

The aft partition and sliding door separates the cabin seating area from the lavatory. The partitions feature a single sliding door that pockets into the right hand partition and slides across the aisle to provide privacy in the lavatory.

The aft partitions incorporate the following features:

- Advisory Lighted Sign on the right hand side (No Smoking / Fasten Seatbelts)
- Sliding door with privacy latch with pop up header and drop down footer
- One air vent

Aft Lavatory

The lavatory is located in the aft most portion of the cabin and occupies both sides of the cabin. The aft lavatory includes the following features:

Right Hand Closet and Vanity

- Advisory Lighted Sign (No Smoking / Fasten Seatbelts)
- General Storage Compartment
- Illuminated Hanging storage (with curtain or bi-fold closing door), which can be fitted with a removable shelf and a bottom drawer
- Toilet Paper dispenser
- Trash Compartment
- Switch Panel
- Hand Towel Stowage
- Counter Top Area
- Provisions for optional water tap and drainable sink

Not available with Increased Range Option

A water system including a sink with tap, fresh water container and waste water container is available as an option.

Aft Bulkhead Facial

- Mirror (installed on removable panel for access to avionics and service related components)
- Stair Stepped back splash and lower panel covered in standard materials

Left Hand Toilet Seat

- Self Contained Electric Flushing Toilet
- Toilet Seat (certified to be occupied during Take-Off and Landing) including lap belt and shoulder harness with inertia reel
- Seat bottom and back cushions upholstered in leather or fabric
- Indirect LED “up wash and down wash” lighting behind seat back

VIP Seats

Each individual VIP seat (Iacobucci) includes:

- Back recline (full recline where available)
- 180° swivelling
- Fore/aft and lateral translation
- Lowerable inboard armrest (optional)
- Provision for under-seat life vest stowage
- Extendable headrest
- Seat restraint system including lap belt, shoulder harness with inertia reel
- Fire resistant leather upholstery and multi-layer foam cushioning



Example of Iacobucci seat

PAC or De Crane seats can also be selected.

Two-place Divan

The side facing two-place divan available in the Corporate 1 and Corporate 3 floor plan includes:

- Under-seat life vest stowage provision
- Seat restraint system including lap belt, shoulder harness with inertia reel
- Fire resistant leather upholstery and multi-layer foam cushioning



A dual floor drawers kit is available as an option.

LH & RH One-Place Divan

The side facing one-place divan is available in the Corporate 1 (1) and Corporate 4 (2) configurations and includes:

- Underseat lifevest stowage provision
- Restraint system including lap belt and dual shoulder harness with inertia reel
- Fire resistant leather upholstery and multi-layer foam cushioning



A single floor drawer kit is available as an option.

Folding tables

The Club section includes one table on each side, foldable and stowable within sideledge.



Lightweight Seats (“Shuttle” only)

Each seat includes:

- 10° back recline
- Ashtray in armrest
- Under-seat life vest stowage pocket
- Folding In-arm table (front row seats)
- Rear tables
- Seat restraint system including lap belt, shoulder harness with inertial reel .
- Seat back pocket
- Fire-resistant fabric upholstery



Mid Cabin Refreshment Cabinet *(available only on Corporate 1 and 4)*

The mid cabin refreshment cabinet is available only on the Corporate 1 and 4 floorplan and is the largest refreshment cabinet available on the Avanti EVO. This low height cabinet’s features may be configured in a several different ways. The features are as following:

- Storage for (2) hot beverage carafes
- Miniature liquor bottle stowage
- Ice Chest or Ice Drawer
- Glass Stowage
- Work Surface and Cutting board
- Napkin and Condiment stowage
- General Stowage
- Trash Compartment
- Internal Lighting

A heated liquid container is available as an option. Smaller cabinets are available for the other floor plan configurations:

Midship Pyramid Cabinets *(available only on Corporate 2 & 3)*

The midship pyramid cabinets are designed to utilize the triangular space created between the two single seat backs. This cabinet can be selected on floorplan Corporate 2 and 3 and will provide additional stowage and refreshment items either by two or three drawers. The cabinet can be placed on both sides in Corporate 2 and only on left hand side on Corporate 3. The cabinet can contain the following features:

- Glass Stowage
- Ice Chest
- Carafe Stowage
- General Stowage

LH & RH (Left Hand & Right Hand) Aft Pyramid Cabinets(Evaporator Covers)

Pyramid Cabinets are located adjacent to aft partitions on the cabin side. They provide storage in the space left between the forward facing seat and the partition and closure for the LH & RH Air Conditioning Evaporator Units.

10.6.1 STANDARD CABIN LAYOUTS / FLOOR PLANS

The Avanti EVO is available in several different floor plans, all the floor plans feature an aft lavatory with closet and a forward set of cabinets dividing the flight deck from the cabin seating area.

The floor plans' in the Corporate feature (4) four single seats arranged in an aft club grouping just forward of the lavatory divider.

The cabin area forward of the club grouping can be arranged with a combination of single seats or side facing divans and cabinets to create different floor plans with an emphasis on number of passengers and galley amenities.

The Floor plans are as follows:

- Corporate Option 1, (7) passengers with (8th) including lavatory seat
- Corporate Option 2, (6) passengers with (7th) including lavatory seat
- Corporate Option 3, (7) passengers with (8th) including lavatory seat
- Corporate Option 4, (6) passengers with (7th) including lavatory seat
- Shuttle Option, (7) passengers all fwd facing with (8th) including lavatory seat

10.6.1.1 CABIN LAYOUTS - CORPORATE OPTION 1 – “ARMONIA”



Corporate Option 1 – “Armonia”

FLOOR PLAN

1. Divan (2 place)
2. Single seat
3. Storage closet
4. Divan (1 place)
5. Refreshment cabinet
6. Fold out executive table
7. Belted toilet seat
8. Optional sink
9. LH & RH pyramid cabinets

Passenger capacity of (8) including lavatory seat.

Main Features:

- Four single seats arranged in an aft club grouping
- Two place side facing divan (right hand)
- Single side facing divan
- Refreshment cabinet (left hand) with stowage and drawers
- Aft Lavatory with closet
- Optional aft divan cabinet

Seating: VIP seats:

- Full recline where available
- 180° swivel and fore/aft and lateral translation
- Sliding / drop down inboard (outboard optional) armrest (only on certain type of seats)
- Life vest storage compartment in seat base

One place & two places divans:

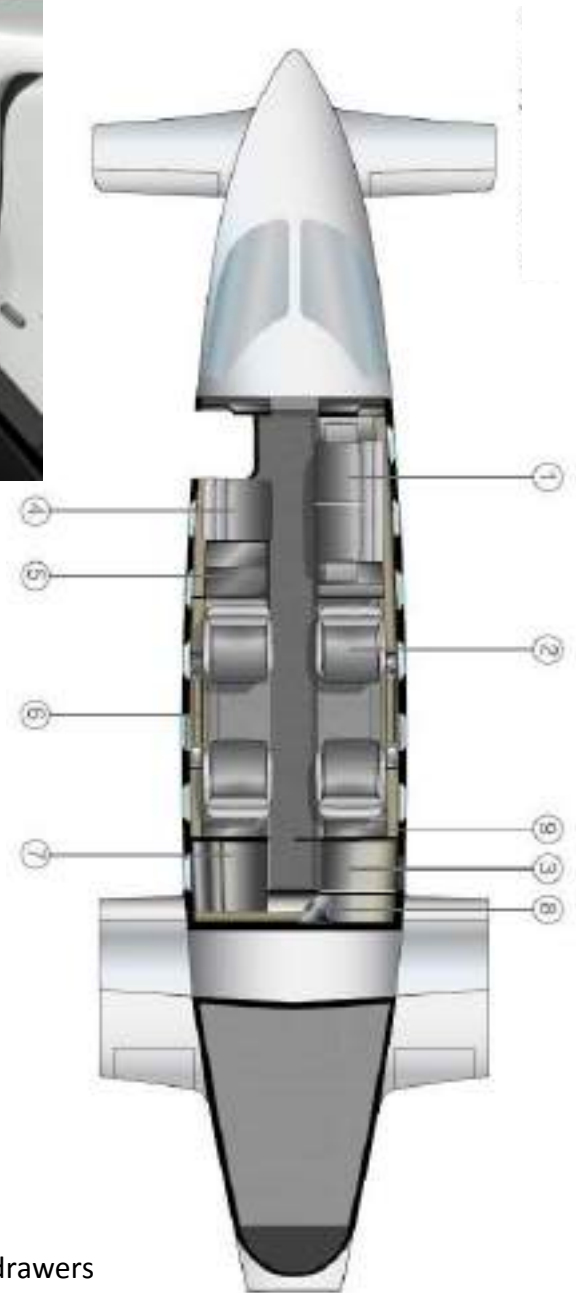

Corporate “Armonia” layout

- Storage compartment under divans
- Optional for 2-place divan:
- End cabinet for storage and general stowage
 - Floor drawers
- Optional for 1-place divan:
- General stowage floor drawers

Armledge and Shell

- Headliner
- Passenger Service Panels (PSU), featuring continuous LED lights for up wash and down wash lighting
- Window Panels, featuring manually operated, encapsulated window shades
- Sideledge and Dado, featuring club tables, dual drink- holders, light switches and storage compartments with universal electrical outlets

LH Refreshment Cabinet

- Miniature liquor bottle stowage
 - Ice chest or ice drawer
 - Glass stowage
 - Napkin stowage
 - Miscellaneous stowage
 - Trash container
- Optional:
- Hot beverage container/dispenser

LH & RH Aft Pyramid Cabinets (Evaporator Covers)

- Closure for Air Conditioning Evaporator Units
- Stowage compartment

Aft Lavatory

- Illuminated wardrobe area for hanging storage
 - Vanity mirror with valance lighting
 - Toilet seat belted for taxi, take-off and landing
 - General storage
 - Self contained electronic flushing toilet
- Optional:
- Vanity Module including sink with water faucet

10.6.1.2 CABIN LAYOUTS - CORPORATE OPTION 2 – “ARIA”



Corporate Option 2 – “Aria”

FLOOR PLAN

1. Cabinet
2. Single seat
3. Storage closet
4. Fold out executive table
5. Belted toilet seat
6. Optional sink
7. LH & RH pyramid cabinets
8. Mid-ship pyramid cabinet

Passenger capacity of (7) including lavatory seat.

Main Features:

- Four single seats arranged in an aft club grouping
- Two single seats facing forward
- Optional pyramid cabinets located between seats
- Optional removable annex cabinet for refreshments (optional)
- Aft Lavatory with closet

Seating: VIP seats:

- Full recline where available
- 180° swivel and fore/aft and lateral translation
- Sliding / drop down inboard (outboard optional) armrest (only on certain type of seats)
- Life vest storage compartment in seat base

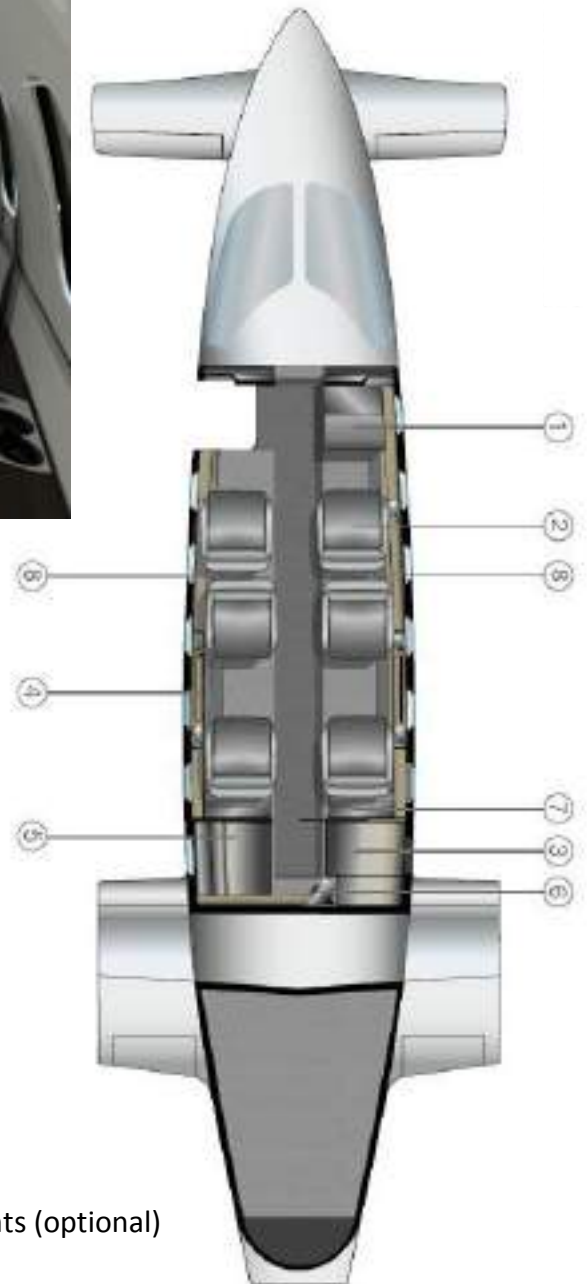

Armledge and Shell

Features:

- Headliner
- Passenger Service Panels (PSU), featuring continuous LED lights for up wash and down wash lighting
- Window Panels, featuring manually operated, encapsulated window shades
- Sideledge and Dado, featuring club tables, dual drink- holders, light switches and storage compartments with universal electrical outlets and data port (optional)

Mid ship Pyramid Cabinets

Features:

- Two or three general stowage drawers

LH & RH Aft Pyramid Cabinets (Evaporator Covers)

Features:

- Closure for Air Conditioning Evaporator Unit
- Stowage compartment

Aft Lavatory

- Illuminated wardrobe area for hanging storage
- Vanity mirror with valance lighting
- Toilet seat belted for taxi, take-off and landing
- General storage
- Self contained electronic flushing toilet

Optional:

- Vanity Module including sink with water faucet

10.6.1.3 CABIN LAYOUTS - CORPORATE OPTION 3 – “ATMOSFERA”



Corporate Option 3 – “Atmosfera”

FLOOR PLAN

1. Divan (2-places)
2. Single seat
3. Storage closet
4. Fold out executive table
5. Belted toilet seat
6. LH & RH aft pyramid cabinets
7. Optional sink
8. Mid-ship pyramid cabinet

Passenger capacity of (8) including lavatory seat.

Main Features:

- Four single seats arranged in an aft club grouping
- Single seat forward facing (left hand)
- Two place side facing divan (right hand)
- Pyramid cabinet located between seats (left hand)
- Aft Lavatory with closet

Seating: VIP seats:

- Full recline where available
- 180° swivel and fore/aft and lateral translation
- Sliding / drop down inboard (outboard optional) armrest (only on certain type of seats)
- Life vest storage compartment in seat base

Two places Divan:

- Storage compartment under divan

Optional:

- End cabinet for storage and general stowage
- Floor drawers

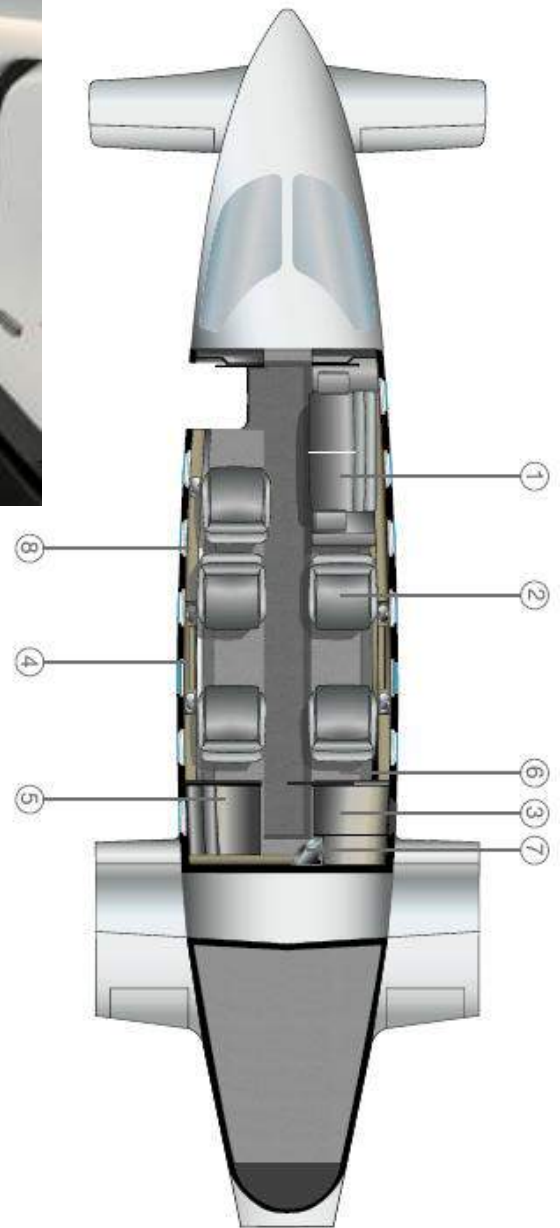

Armledge and Shell

Features:

- Headliner
- Passenger Service Panels (PSU), featuring continuous LED lights for up wash and down wash lighting
- Window Panels, featuring manually operated, encapsulated window shades
- Sideledge and Dado, featuring club tables, dual drink- holders, light switches and storage compartments with universal electrical outlets and data port (optional)

LH Midship Pyramid Cabinet

Features:

- Two or three general stowage drawers

LH & RH Aft Pyramid Cabinets (Evaporator Covers)

Features:

- Closure for Air Conditioning Evaporator Unit
- Stowage compartment

Aft Lavatory

- Illuminated wardrobe area for hanging storage
- Vanity mirror with valance lighting
- Toilet seat belted for taxi, take-off and landing
- General storage
- Self contained electronic flushing toilet

Optional:

- Vanity Module including sink with water faucet

10.6.1.4 CABIN LAYOUTS - CORPORATE OPTION 4 – “AMBIENTE”



FLOOR PLAN Corporate Option 4

1. RH Divan (1-place)
2. Single seat
3. Storage closet
4. LH Divan (1 place)
5. LH Pyramid Cabinet
6. Fold out executive table
7. Belted toilet seat
8. Optional sink
9. RH aft pyramid cabinet
10. LH aft pyramid cabinet
11. RH Refreshment cabinet

Passenger capacity of (7) including lavatory seat.

Main Features:

- Four single seats arranged in an aft club grouping with increased distance between aft /fwd seats (club area).
- Single seat forward facing (left hand)
- Two single place side facing divans (left & right hand)
- Refreshment cabinet between RH single divan and RH aft seat
- Pyramid cabinet located between LH single divan and LH aft seat
- Aft Lavatory with closet

Seating: VIP seats:

- Full recline where available (PAC only)
- 180° swivel and fore/aft and lateral translation
- Sliding / drop down inboard (outboard optional) armrest (only on certain type of seats)
- Life vest storage compartment in seat base

One place divans:

- Storage compartment floor drawers under divans

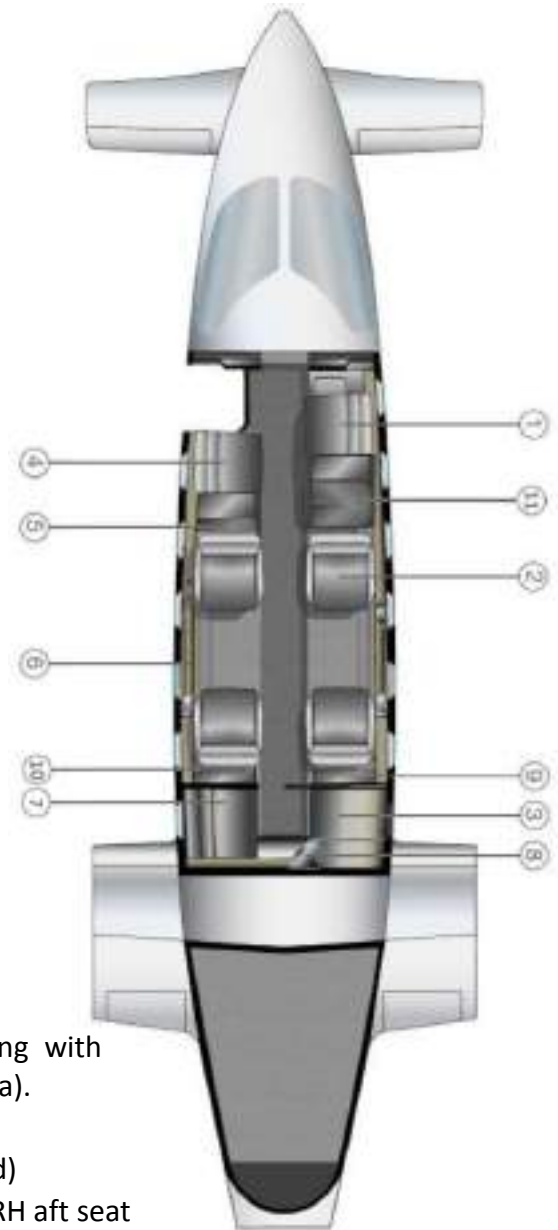

Armledge and Shell

Features:

- Headliner
- Passenger Service Panels (PSU), featuring continuous LED lights for up wash and down wash lighting
- Window Panels, featuring manually operated, encapsulated window shades
- Sideledge and Dado, featuring club tables, dual drink- holders, light switches and storage compartments with universal electrical outlets and data port (optional)

RH Refreshment Cabinet

Features:

- Stowage compartments

LH Pyramid Cabinets

Features:

- Two or three general stowage drawers

LH & RH Aft Pyramid Cabinet (Evaporator Cover)

Features:

- Closure for Air Conditioning Evaporator Unit
- Stowage compartment

Aft Lavatory

- Illuminated wardrobe area for hanging storage
- Vanity mirror with valance lighting
- Toilet seat belted for taxi, take-off and landing
- General storage
- Self contained electronic flushing toilet

Optional:

- Vanity Module including sink with water faucet

10.6.1.5 CABIN LAYOUTS – SHUTTLE LAYOUT – SEVEN AIRLINE TYPE SEATS



Shuttle Layout

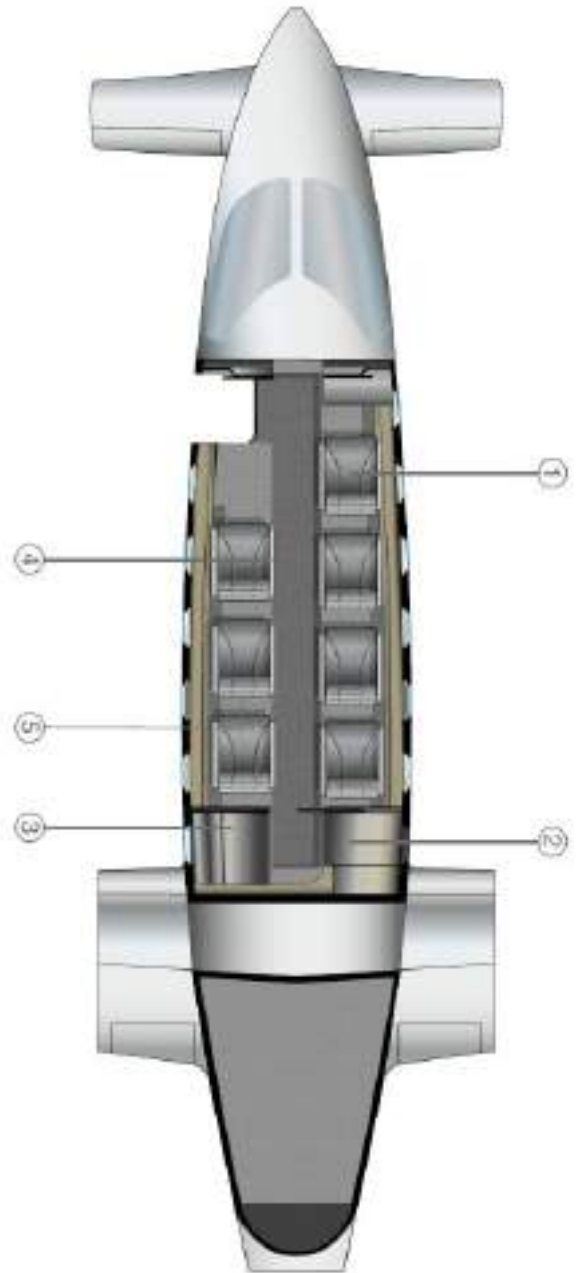

FLOOR PLAN

1. Single seat
2. Storage closet
3. Belted toilet seat
4. In arm tray table (first row only)
5. Flip down tray table (typical all other seats)

Passenger capacity of (8) including lavatory seat.

Main Features:

- Seven forward facing airline style seats
- Flat arm ledge
- Aft Lavatory with closet

Seating: Lightweight seats

LH & RH Aft Pyramid Cabinet (Evaporator Cover)

Features:

- Closure for Air Conditioning Evaporator Unit
- Stowage compartment

10.6.2 OPTIONAL AERO-AMBULANCE CONFIGURATION

10.6.2.1 STRETCHERS FOR MEDEVAC QUICK CONVERSION

The interiors of the P.180 Avanti EVO can be easily (approx. 2 h work) converted into a one or two stretchers MEDEVAC configuration cabin, by removing some of the VIP seats and installing one or two LIFEPORT™ Basic Life Support (BLS) systems.

For weight saving reasons and for convenience of MEDEVAC operations (i.e. more room available for the medical personnel), it is recommended to replace the remaining VIP seats with lighter seats equipped with lowerable armrests available as a special option.

Each LIFEPORT™ BLS system includes:

- One or two 6-foot Patient Loading Utility System (PLUS) equipped with power supply outlets and with oxygen, air and vacuum outlets
- One or two 6-foot AEROSLED stretcher with restraint system
- One patient load ramp with stowage compartment

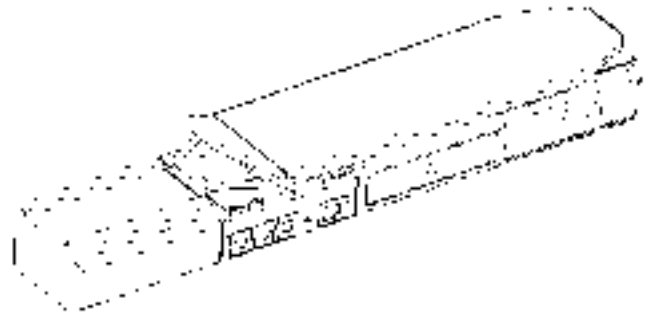

10.6.2.2 CABIN LAYOUT – AERO AMBULANCE

The P.180 Avanti EVO cabin can be configured as a EASA/FAA certified Aeroambulance.

Two different layout versions are available:

- 1 stretcher configuration, with seating for 4+1 medical crew / attendants
- 2 stretchers configuration, with seating for 2+1 medical crew / attendants

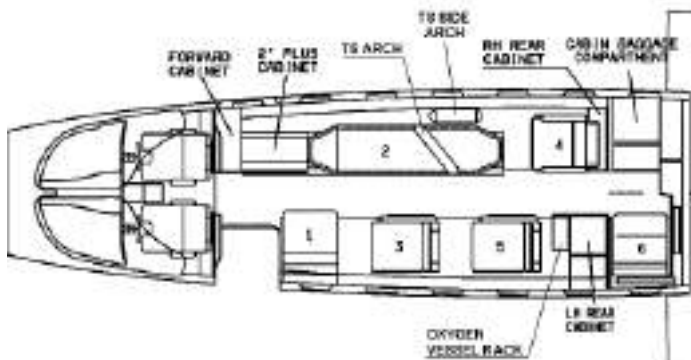

Single Stretcher Layout

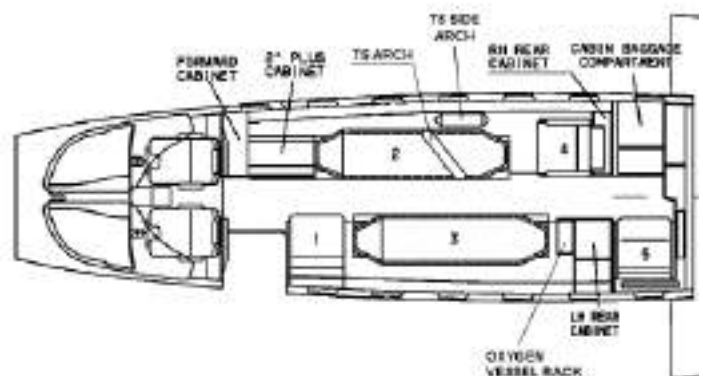

Double Stretcher Layout

10.6.3 SURVEILLANCE VERSION

The P.180 Avanti EVO can be configured as a surveillance aircraft equipped with a FLIR/TV Camera system, the SeaFLIR™II manufactured by FLIR SYSTEMS, thus enabling a wide range of mission capabilities, including self-protection, counter-terrorism, drug interdictions, fisheries patrol and environmental monitoring, mine detection, reconnaissance, surveillance, and Search and Rescue operations.

The Surveillance version is equipped with a dedicated console installed in the passenger cabin.

10.6.4 CARGO & COMBI VERSION

A CARGO Kit and a COMBI Kit are available for installation in the cabin compartment, after total or partial removal of passenger accommodations, to allow for full cargo or combined cargo/passenger operations.

The maximum permissible number of seats is two (i.e. Flight Crew only) for the Cargo configuration and four (i.e. Flight Crew plus two passengers in the foremost row) for the Combi configuration. The kit includes:

- Protections to prevent damage during cargo handling for the lower sidewalls and for the inflatable door seal
- Cargo restraint system, including:
 - Cargo nets
 - Restraint straps
 - Tiedown fittings
- Floor carpet made of fire-resistant material over the entire floor area.

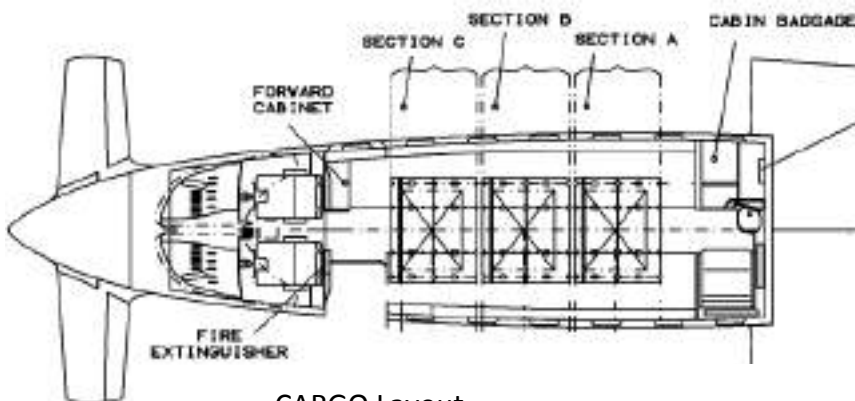

CARGO Layout

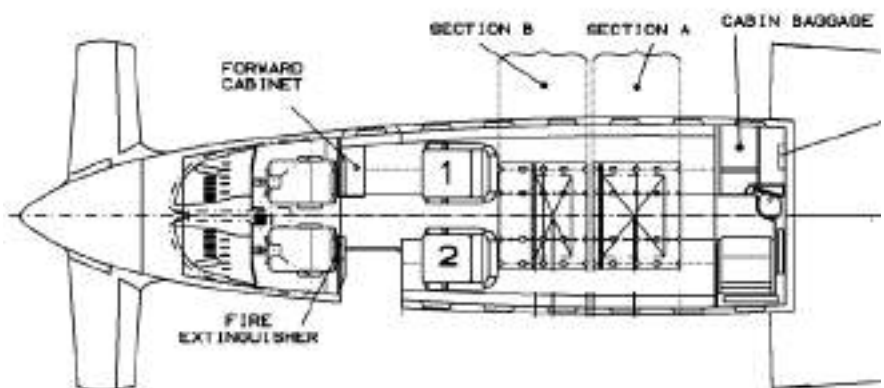

COMBI Layout

10.6.5 FLIGHT INSPECTION VERSION

The P.180 Avanti EVO can be equipped with a full Flight Inspection capability or with a provision only; up to today these version are available with “Shuttle” cabin layout but can be developed also for the other cabin layouts.

When equipped with the Flight Inspection Provision only, the aircraft will retain the standard cabin layout and will install an additional set of antennas, dedicated to the Flight Inspection System, with all the harnesses/cables and the means necessary to stow/isolate them.

When equipped with the Full Flight Inspection capability:

- One RH seat in the aft side of the A/C is substituted by the FIS Operator console(FIOC);
- One LH seat in the aft side of the A/C could be substituted by a FIS Rack (FIDAR) to host additional equipment if needed by the applicable Flight Inspection capabilities requirements;

Moreover, if requested, a dedicated operator seat (a copilot seat with an adapter) can be installed in lieu of the latest RH seat.

Aside, the certified layout (console/rack/operator seat) applied to the “Shuttle” configuration.

The “Full Flight Inspection” will provide the aircraft with the capability to inspect:

- Navigation & Communication Aids/facilities,
- Radar facilities,
- Visual Approach Aids,
- Combined Procedures (approach/enroute)
- Instrument Flight Procedure (Dep., Enroute, Arrival)

Below a pictorial of a “single” console with operator seat applied to a “Corporate “2” configuration

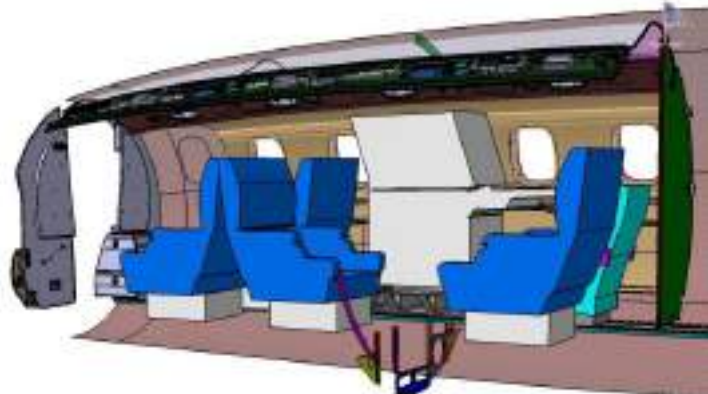
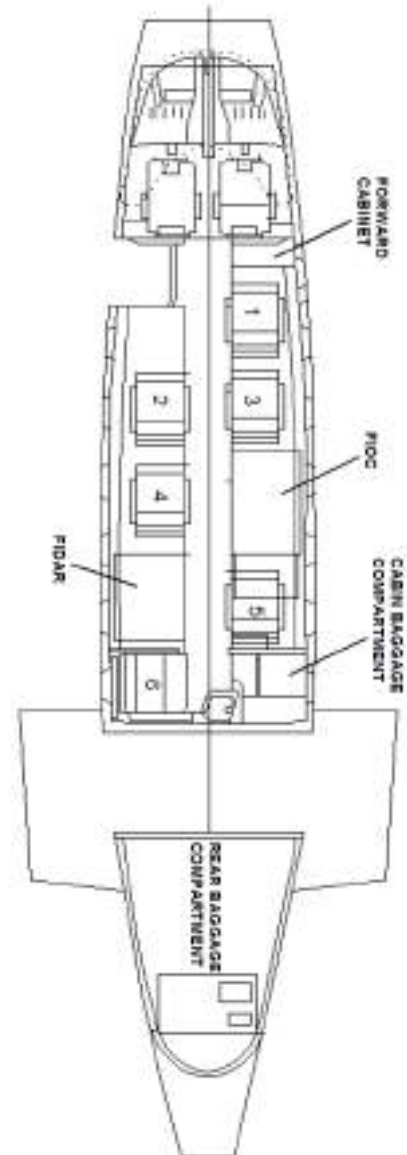

When in Flight Inspection configuration, P.180 Avanti EVO shall NOT be equipped with Community Noise reduction package (new Hartzell propellers with scimitar blades and torque limiter). The aircraft shall retain previous Hartzell propellers in order to allow operation at 2000 rpms.

10.6.6 INTERIOR OPTIONS

10.6.6.1 RIGHT-HAND DIVAN END CABINET (CORPORATE 1, 3 & 4)

This optional cabinet is designed for installation on the forward right side of the cabin, at the aft end of the two place divan, to provide armrest comfort and additional storage space. It features:

- Two storage drawers
- Dual drink holder



10.6.6.2 WATER SYSTEM FOR THE LAVATORY MODULE

Optional Vanity Sink with Faucet including fresh water tank and waste water collection tank to be installed on the right hand aft corner of the lavatory module.

The system include a water tank, an electrical pump (power supplied with 28 VDC) and relevant pipings, installed inside the lower part of vanity closet assy.



10.6.6.3 HOT BEVERAGE DISPENSER

Heated liquid container/dispenser to be installed in place of the standard carafes in the top part of the mid cabin refreshment cabinet.



10.6.6.4 FLOOR DRAWER FOR THE ONE & TWO PLACE DIVAN

Single or dual drawers kit for installation in the base of the one place left hand side divan and two place right hand side divan.



Corporate 1 & 4



Corporate 2 & 3

10.6.6.5 SHEEP SKIN FOR PILOT AND CO-PILOT SEATS

Sheep skin cover to provide Pilots with a better comfort both in the hot and the cold season.

10.6.7 CABIN MATERIALS AND FINISHING

Standard upholstery materials include:

- carpet, 8 mm (0.3 in.) thick, 1,750 Kg/m² (0,35 lbs./ft²)
- leather, 0.8-1.2 mm (0.03-0.05 in.) thick, 0,890 Kg/m² (0.18 lbs./ft²)
- foam, 150 kg/m³ (9,35 lbs./ft³)

Premium materials and/or finishes are available on Customer's request with lead times to be defined on a case-by-case basis.

NOTE:

Non standard materials may cause extra weight and a subsequent reduction of useful payload.

All upholstery materials shall comply with the requirements of specification PS180-25-021 "Materials for aircraft furnishing".

10.6.8 EXTERNAL PAINTING

10.6.8.1 STANDARD PAINTING SCHEME

The standard painting scheme is fully white color.

10.6.8.2 FULLY CUSTOMIZED PAINTING SCHEME (SOLID COLORS)*

Non standard paint scheme featuring solid colors may be selected as option. Logo and drawing scheme according to customer's specific requirements.

10.6.8.3 FULLY CUSTOMIZED SPECIAL MICALIZED / METALIZED PAINTING SCHEME*

Non standard paint scheme with special micalised / metalized colors may be selected as option. Logo and drawing scheme according to customer's specific requirements.

*NOTE:

Painting customization is subject to technical feasibility in accordance to the Maintenance Manual limitations (absorption of radiation limitations) and will have a not negligible payload reduction that has to be considered by the customer.

11 INSPECTIONS

The inspection schedule consists of individual maintenance checks, performed at 200, 600, 1800, 3600 flight hour intervals, and of other flight hour and calendar scheduled inspections:

- 200FH Tasks – Every 200 Flight Hours except when B, C, D inspections occur
- B Check – Every 600 Flight Hours except when D inspection occurs
- C Check – Every 1800 Flight Hours except when D inspection occurs
- D Check – Every 3600 Flight Hours

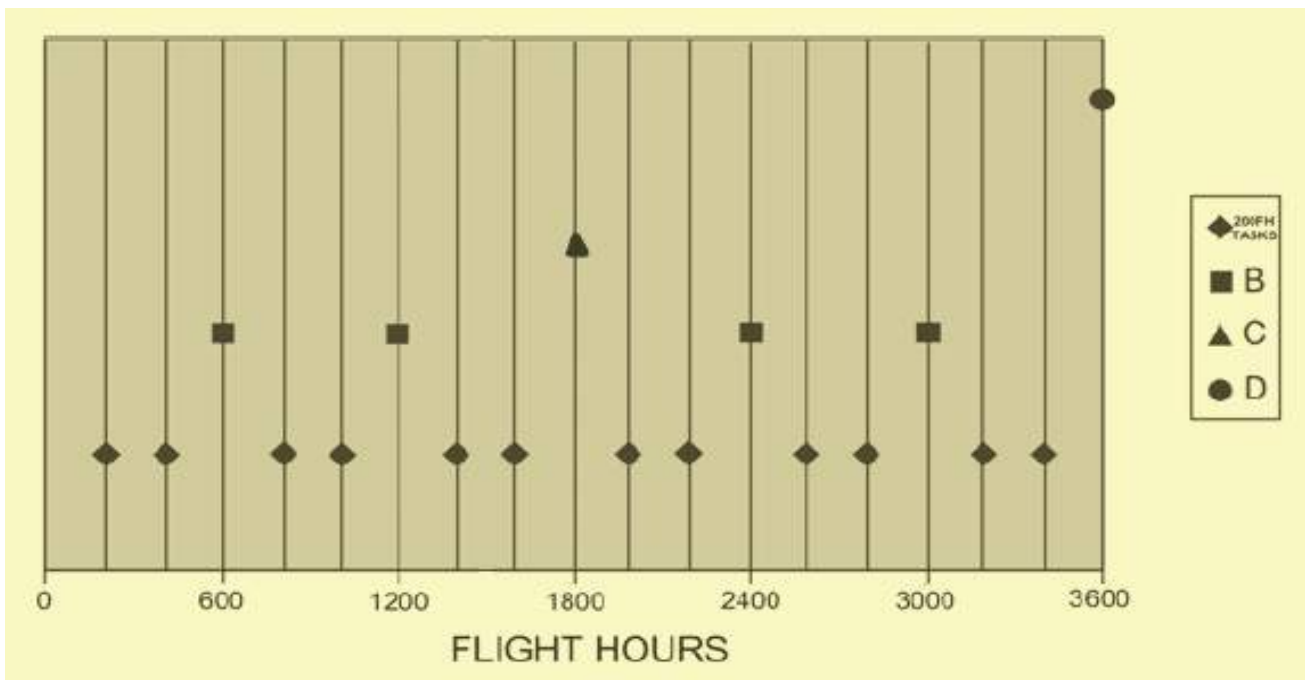

P.180 Inspection Schedule

The PT6A-66B engine requires Hot Section Inspection at 1800 hrs and Overhaul at 3600 hrs. Engine routine checks shall be performed during the airplane preflight check and minor checks shall be performed in conjunction with “200 FH” Interval Inspection. The checks must be complied within the limits specified by P&WC if not otherwise specified by Piaggio Maintenance Schedule.

The Hartzell HC-E5N propellers require overhaul every 6 years or 3600 hrs whichever occurs first.

The Main Landing Gear shall requires overhaul every 10.000 landings or 15 years whichever occurs first.

APPENDIX A - NOTES ABOUT THE 3-LIFTING-SURFACE DESIGN

Some additional information is given here about the Avanti EVO 3-Lifting-Surface design.

The Avanti EVO's distinctive shape is not simply due to a styling research but was dictated by the design goals set for the aircraft: a wide body, stand-up cabin, jet-like performance and turboprop fuel efficiency. After an intensive aerodynamic analysis and several hundreds of hours of wind tunnel tests, PIAGGIO AEROSPACE engineers concluded that these goals could not be achieved with conventional aircraft configurations.

Thus the AVANTI EVO project evolved to include:

- PIAGGIO's patented *Three-Lifting-Surface Configuration* (3LSC), which permits a 34-percent reduction in total wing area over conventional designs, thereby reducing weight and drag;
- A non-cylindrical, low-drag fuselage shape, developed through extensive wind tunnel testing to allow a large cabin cross section without a large drag penalty;

While its surface appearance is radically different from other aircraft, there is much to the Avanti EVO that pilots and maintenance personnel will find conventional and familiar:

- Well known and widely used systems;
- 90-percent aluminium construction;
- Conventional flight controls.

Thanks to this unique combination of the innovative and the conventional, you can enjoy the EVO's exhilarating performance and exceptional comfort, while flying with confidence in the *Avanti's* proven technologies and systems.

The AVANTI EVO's unique 3LSC design utilises a small forward wing, a high-aspect-ratio main wing and a small horizontal stabiliser atop the conventional vertical stabiliser.

This combination reduces drag by minimising the amount of downward force the horizontal stabiliser must produce to balance the nose-down pitching moment created by the main wing lift and pressure distribution acting aft of the centre of gravity.

In a conventional 2-surface configuration, this nose-down pitching moment, neutralised (trimmed) by a downward force created by the "negative" lift, can be as much as 10% of the aircraft's weight at cruise and as much as 20% during approach. The result is that the main wing must provide the lift to support 110% to 120% of the aircraft's weight. The net effect is that the main wing must be larger than a wing required to support only the aircraft's weight.

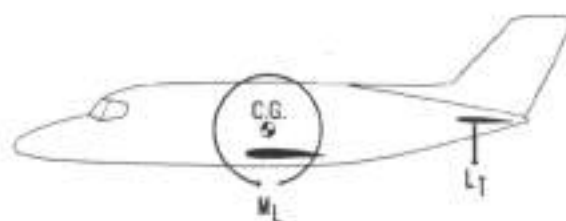

Conventional aircraft

M_L = Nose down pitching moment created by the main wing's lift

L_T = Negative trim lift required to neutralise main wing's pitching moment

The extra lift required by the main wing and the “negative” lift generated by the horizontal stabiliser produces additional induced drag (the drag associated with the generation of lift). This additional drag would be not present if the aircraft's weight were supported by the main wing only and the “negative” lift was not required. A larger wing also results in additional structural weight and profile drag (the drag associated with size).

With the AVANTI EVO's 3LSC design, the small forward wing produces “positive” upward lift required to trim the nose-down pitching moment created by the main wing. The horizontal stabiliser, in cruise configuration, is producing negligible “positive” or “negative” lift.

The total lift produced by the forward and main wing is basically only that required to support the aircraft's weight. This lower lift requirement results in less wing area, hence, lower profile drag, lower induced drag and lower structural weight.

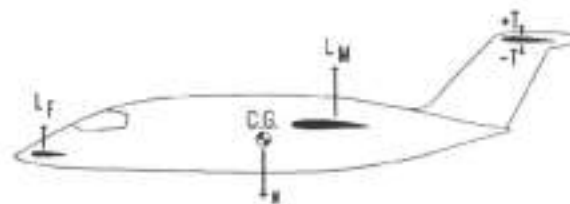

3-Lifting-Surface design

W = Aircraft weight

L_M = Main wing lift

L = Lift = $L_F + L_M + L_T$

T = Lift to trim aircraft (negligible)

L_F = Forward wing lift

Although the horizontal tail, in some configurations, can produce a small amount of “negative” lift, the drag and weight penalty are minimal and the benefits to controllability are substantial. When the main wing's flaps are lowered for takeoff and landing the centre of lift moves even further aft, creating a large nose-down pitching moment. The flap on the *Avanti's* forward wing is programmed to extend the exact amount to provide the additional up-lift to balance out the nose-down moment created by the main wing flaps.

The horizontal stabiliser with its conventional elevator allows the pilot precise pitch control.

With the pure canard (2-surface) configuration, pitch control is far more difficult and may require the weight and complexity of variable sweep plus elevators or flaps on the forward wing.

The *Avanti's* pitch control and stall characteristics are so conventional that the aircraft does not require a stick-pusher or stick-shaker as some conventional aircraft design.

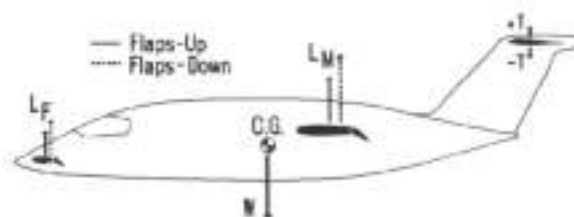

Flap effect

Main wing centre of lift moves aft with flap deflection. Forward wing flaps are programmed to provide additional lift required to balance the increased nose-down pitching moment.

APPENDIX B – NEW AIRCRAFT WARRANTY

A. Aircraft Manufacturer's Limited Warranty

Manufacturer warrants that the Aircraft, at the time of its delivery from Manufacturer, shall be free from all defects in material and workmanship and from defects inherent in its design relative to the known state of the art at the time of such design. This warranty does not apply to Aircraft operated or maintained contrary to Manufacturer's service and flight manuals, as they may be in effect from time to time.

Upon receipt of prompt written notification from the Customer, including satisfactory evidence of the defects and return of the defective part when possible, Manufacturer shall:

1. if the failure occurs either within the first 1,000 flight hours or 24 months after delivery to Buyer, whichever occurs earlier, either repair or replace any defective item (except engines referenced in paragraph B below).
2. if the failure occurs either within the first 1,000 flight hours or 24 months after delivery to Buyer, whichever occurs earlier, either repair or replace all defective items which are manufactured by Manufacturer or those which are manufactured by vendors to Manufacturer's detailed design specifications.
3. if the failure occurs both within the first 5,000 flight hours and within 60 months after delivery of the Aircraft to Buyer, either repair or replace any defective fuselage, empennage, wing, or control surface.

B. Engines Warranted by Pratt & Whitney

Engine warranty will start from the day of the final delivery of the aircraft by the Manufacturer to the Buyer and will be provided and administered by the engine manufacturer (Pratt & Whitney Canada Inc.). Specific details for the implementation of such warranty will be furnished to the Buyer by the Manufacturer upon delivery of the Aircraft.

C. Avionics Warranted by Applicable Manufacturers

Rockwell Collins avionics equipment and components are warranted by the manufacturers for a period of 5 years. Buyer will receive any remaining life of those warranties in accordance with each respective manufacturer's warranty program starting from the date of final delivery of the aircraft by the Manufacturer to the Buyer.

D. Labour Statement

With regard to paragraphs A(1), A(2), and A(3) above, the repair or replacement of defective parts under this warranty will be made by or through any Avanti Authorised Service Centre without charge for parts and/or labour for removal, installation and/or actual repair of such defective parts.

APPENDIX C – OPTIONAL EQUIPMENT LIST SUMMARY

C.1 Aircraft configurations				
	Option Id.	Description	Estimated Weight (Lbs)	Estimated Weight (kg)
	XR-001	Extended Range Option	64	29
C.2 Cabin layouts				
Aircraft Weight (lbs) (includes P-001 painting)	Option Id.	Description	Estimated Weight (Lbs)	Estimated Weight (kg)
8220	I-001	Corporate option 1 “Armonia”, featuring seven VIP seats (Iacobucci IHF): 4 Club seats 1 side facing, two-place divan 1 side facing, one-place divan LH Refresment Cabinet	380	172
8220	I-001a	Same as above with 4 Club seats by PAC (Full recline, lowerable inboard armrest)	380	172
8160	I-001b	Same as above with 4 Club seats by De Crane	320	145
8200	I-002	Corporate option 2 “Aria”, featuring six VIP seats (Iacobucci IHF): 4 Club seats, 2 forward facing seats	360	163
8190	I-002a	Same as above with 6 PAC armchairs (Full recline, lowerable inboard armrest)	350	159
8110	I-002b	Same as above with 6 Club seats by De Crane	270	122
8210	I-003	Corporate option 3 “Atmosfera”, featuring five VIP seats (Iacobucci IHF): 4 Club seats, 1 side facing, two-place divan, 1 forward facing VIP seat Two Drawers Pyram. Cab. (LH)	370	168
8210	I-003a	Same as above with 5 PAC armchairs (Full recline, lowerable inboard armrest)	370	168

8140	I-003b	Same as above with 5 De Crane armchairs	300	136
8200	I-004	Corporate option 4 “Ambiente”, featuring seven VIP seats (Iacobucci IHF): 4 Club seats 2 side facing, one-place divan RH Refreshment Cabinet Two Drawers Pyram. Cab. (LH)	350	159
8200	I-004a	Same as above with 4 Club seats by PAC (Full recline, lowerable inboard armrest)	350	159
8150	I-004b	Same as above with 4 Club seats by De Crane	300	136
7850	I-010	Shuttle layout, featuring seven seats:	210	95
		7 forward facing lightweight seats (airline style)		

C.3 Interior options

	Option Id.	Description	Estimated Weight (Lbs)	Estimated Weight (Lbs)
	I-110	Kit of seven lightweight seats airline style (loose supply)	208	94,3
	I-120	Ambulance kit (Single Stretcher)	195	88,4
	I-121	Ambulance kit (Two Stretchers)	357	161,9
	I-011	Floor drawer for the one place divan (Corporate 1 & 4)	4,1	1,9
	I-012	Floor drawers for the two place divan (Corporate 1 & 3)	10,67	4,8
	I-013	Right-hand divan end cabinet (for Corporate 1 and 3 layouts)	16,76	7,6
	I-014	RH Aft 1 Drawer Cabinet (for Corporate 2 and 4 layouts)	9,75	4,4
	I-015	RH Aft 2 Drawers Cabinet (for Corporate 2 and 4 layouts)	13,12	6,0
	I-016	Hot Beverage Dispenser for the Refreshment Cabinet (for Corporate 1)	4,4	2,0
	I-017	Pyramid 2 Drawers Cabinet (LH or RH)	13,98	6,3

	I-018	Pyramid 3 Drawers Cabinet (LH or RH)	18,35	8,3
	I-019	Vanity sink and water system for the Lavatory Module	20	9,1
	I-020	Sheep skin for Pilot and Co-pilot seats	4	1,8

C.4 Avionics Options

	Option Id.	Description	Estimated Weight (Lbs)	Estimated Weight (kg)
	A-001	HF Wiring Provisions	24	10,9
	A-002	HF Radio System (1)	24,5	11,1
	A-011	Full Provision for CVR/CVDR installation	7,4	3,4
	A-012	Cockpit Voice Recorder (2)	12,2	5,5
	A-013	CVR System Portable Interface Unit for Data Retrieval	N/A	N/A
	A-014	Cockpit Voice & Flight Data Recorder Combo Unit	19	8,6
	A-015	ACAS II 7.1 (Exchange – Replacing TCAS I) (delta weight)	24	10,9
	A-016	“Enhanced Safety of Flight” Package TCAS II + EGPWS (Exchange)(delta weight) (3)	28	12,7
	A-017	Lightning Detection System (Stormscope)	14,8	6,7
	A-018	Satellite Based Augmentation System (SBAS/LPV) capability (3)	0	0,0
	A-019	VHF Datalink Universal Graphical Weather (Requires installation of a third Collins Nav/Com and Antenna)	10	4,5
	A-024	Inmarsat Satellite phone and Wi-Fi Cabin Connectivity System (4)	17,2	7,8
	A-025	EFB (iPad Mini) Provisions	0,74	0,3
	A-028	Video Capability for the MFD	0	0,0
	A-030	Engine Data Acquisition & Monitoring System – P&WC / Altair(4)	5	2,3
	A-031	Engine Data Transfer Unit – P&WC / Altair (5)	5	2,3

C.5 Systems and Miscellaneous equipment				
	Option Id.	Description	Estimated Weight (Lbs)	Estimated Weight (kg)
	S-001	First Aid Oxygen	3,8	1,7
	S-002	Portable Oxygen Cylinder	9	4,1
	S-003	Nose Landing Gear Gravel kit (6)	2	0,9
	S-004	JAR OPS 1 / FAR 135 KIT	14	6,3
	S-006a-c	Lead Acid Battery (Exchange)(delta weight)	10	4,5
	S-006b	Low maintenance Battery Ni-Cd (Exchange)(delta weight)	2	0,9
	S-007	14VDC Auxiliary Power	2	0,9
	S – 008	Provision for Portable ELT stowage	-	-
	S-009	Life Raft (7 Person / overload 10 Persons, triple frequency ELT, JAR-OPS compliant SEP kit)	46	20,8
	S-011	Modular IFE – Flight Display - (plug-in monitors, CD/DVD player w/ Moving map, wireless headsets audio, iPod connector)	To be defined after Customer selection	

C.6 Painting options				
	Option Id.	Description	Estimated Weight (Lbs)	Estimated Weight (kg)
	P-001	Fully Customized Painting Scheme (Non Micalized Colors) (7)	100	45,4
	P-002	Fully Customized Special Micalized Painting Scheme (7)	150	68,0

Note (1): Requires the installation of the HF wiring provision (A-001)

Note (2): Requires the installation of the full provision for CVR installation (A-004)

Note (3): EPGWS and SBAS/LPV cannot be installed together for operating technical reason

Note (4) Inmarsat Satellite phone and ADAS cannot be installed together.

Note (5) Requires the installation of the provision for Engine Data Acquisition & Monitoring System (A-030)

Note (6): Required for operation on unpaved runways in accordance with the AFM supplements.

Note (7): Painting weight may according the customer selected scheme; it is about 100 lbs for solid color and 150 lbs for micalized colors (from green)