

# HOAC AUSTRIA

---

## FLIGHT MANUAL

# DV 20 KATANA

---

Category of Airworthiness : Normal  
Applicable Airworthiness Requirements : JAR-VLA including Amendment VLA/92/1  
Serial No. :  
Registration :  
Date of Issue : October 20, 1993  
Document No. : 4.01.02

This manual is part of the airplane DV 20 Katana and must be carried on board at all times! Scope and revision status can be found in the List of Effective Pages and in the Record of Revisions. The pages identified as "BAZ-appr." in the List of Effective Pages are approved by:

Signature

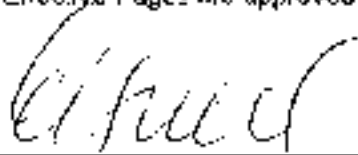

Authority

BUNDESREPUBLIK ÖSTERREICH  
BREMSEN- und VERBREMNER-VERBAND

Stamp

Schnitz- u. Holzwerkstoffe GmbH  
A-1000 Wien



Date of approval

03. DEZ. 1993

This airplane is to be operated in compliance with the information and limitations contained herein.

## PREFACE

Congratulations on your choice of the DV 20 KATANA.

Safe handling of an airplane increases and ensures your safety and provides you with many hours of enjoyment. For this reason you should take the time to familiarize yourself with your new KATANA airplane.

We ask that you carefully read this Flight Manual and to pay special attention to the recommendations given. A careful study of the manual will reward you with many hours of trouble-free flight operation of your KATANA airplane.

All rights reserved. Reproduction of this manual or any portion thereof by any means without the express written permission of HOAC Austria is prohibited.

Copyright © by HOAC Austria, Wr. Neustadt.

Revision No.	Reference	Date October 20, 1993	Page 0 - 2
--------------	-----------	--------------------------	---------------

**TABLE OF CONTENTS**

	<b>Chapter</b>
GENERAL	1
OPERATING LIMITATIONS	2
EMERGENCY PROCEDURES	3
NORMAL OPERATING PROCEDURES	4
PERFORMANCE	5
MASS (WEIGHT) AND BALANCE / EQUIPMENT LIST	6
DESCRIPTION OF THE AIRPLANE AND ITS SYSTEMS	7
HANDLING, PREVENTIVE AND CORRECTIVE MAINTENANCE	8
SUPPLEMENTS	9

## LIST OF EFFECTIVE PAGES

Chapter	Page	Date	Chapter	Page	Date	
0	0-1	Oct. 20, 1993	4	ACG-appr.	3-7	Oct. 20, 1993
	0-2	Oct. 20, 1993		ACG-appr.	3-8	Oct. 20, 1993
	0-3	Oct. 20, 1993		ACG-appr.	3-9	Oct. 20, 1993
	0-4	Nov. 12, 2001		ACG-appr.	3-10	Oct. 20, 1993
	0-5	Nov. 12, 2001		ACG-appr.	3-11	Oct. 20, 1993
	0-6	Nov. 12, 2001		ACG-appr.	3-12	Oct. 20, 1993
	0-7	Oct. 20, 1993		ACG-appr.	3-13	Oct. 20, 1993
1	1-1	Oct. 20, 1993		ACG-appr.	3-14	Oct. 20, 1993
	1-2	Oct. 20, 1993		ACG-appr.	3-15	Oct. 20, 1993
	1-3	Oct. 20, 1993		ACG-appr.	3-16	Oct. 20, 1993
	1-4	Oct. 20, 1993		ACG-appr.	3-17	Oct. 20, 1993
	1-5	Oct. 20, 1993		4-1	Oct. 20, 1993	
	1-6	Dec. 30, 1994		ACG-appr.	4-2	Dec. 30, 1994
	1-7	Oct. 20, 1993		ACG-appr.	4-3	Oct. 20, 1993
	1-8	Oct. 20, 1993		ACG-appr.	4-4	Oct. 20, 1993
	1-9	Oct. 20, 1993		ACG-appr.	4-5	Oct. 20, 1993
	1-10	Oct. 20, 1993		ACG-appr.	4-6	Oct. 20, 1993
	1-11	Oct. 20, 1993	ACG-appr.	4-7	Oct. 20, 1993	
	1-12	Oct. 20, 1993	ACG-appr.	4-8	Dec. 30, 1994	
	1-13	Oct. 20, 1993	ACG-appr.	4-9	Oct. 20, 1993	
	1-14	Oct. 20, 1993	ACG-appr.	4-10	Oct. 20, 1993	
2	2-1	Oct. 20, 1993	ACG-appr.	4-11	Dec. 30, 1994	
	ACG-appr.	2-2	Oct. 20, 1993	ACG-appr.	4-12	Dec. 30, 1994
	ACG-appr.	2-3	Oct. 20, 1993	ACG-appr.	4-13	Oct. 20, 1993
	ACG-appr.	2-4	Dec. 30, 1994	ACG-appr.	4-14	Dec. 30, 1994
	ACG-appr.	2-5	Oct. 20, 1993	ACG-appr.	4-15	Oct. 20, 1993
	ACG-appr.	2-6	Oct. 20, 1993	ACG-appr.	4-16	Oct. 20, 1993
	ACG-appr.	2-7	Oct. 20, 1993	ACG-appr.	4-17	Oct. 20, 1993
	ACG-appr.	2-8	Oct. 20, 1993	5	5-1	Oct. 20, 1993
	ACG-appr.	2-9	Dec. 30, 1994		5-2	Oct. 20, 1993
	ACG-appr.	2-10	Oct. 20, 1993		ACG-appr.	5-3
3	3-1	Oct. 20, 1993	5-4	Dec. 30, 1994		
	ACG-appr.	3-2	Dec. 30, 1994	5-5	Oct. 20, 1993	
	ACG-appr.	3-3	Oct. 20, 1993	ACG-appr.	5-6	Oct. 20, 1993
	ACG-appr.	3-4	Oct. 20, 1993	5-7	Oct. 20, 1993	
	ACG-appr.	3-5	Oct. 20, 1993	ACG-appr.	5-8	Dec. 30, 1994
	ACG-appr.	3-6	Oct. 20, 1993	ACG-appr.	5-9	Dec. 30, 1994
			5-10	Oct. 20, 1993		
			5-11	Oct. 20, 1993		

Chapter	Page	Date	Chapter	Page	Date
6	ACG-appr	5-12	8	8-1	Oct. 20, 1993
		5-13		8-2	May 23, 1995
		5-14		8-3	Oct. 20, 1993
	ACG-appr.	6-1		8-4	Oct. 20, 1993
		6-2		8-5	Oct. 20, 1993
		6-3		8-6	Oct. 20, 1993
		6-4		8-7	Oct. 20, 1993
		6-5	9	9-1	Oct. 20, 1993
		6-6		6-7	Dec. 30, 1994
	ACG-appr.	6-7	9		
		6-8			
		6-9			
		6-10			
		6-11			
		6-12			
		6-13			
		6-14			
		6-15			
6-16					
6-17					
6-18					
7	7-1	Oct. 20, 1993			
	7-2	Oct. 20, 1993			
	7-3	Oct. 20, 1993			
	7-4	Oct. 20, 1993			
	7-5	Oct. 20, 1993			
	7-6	Oct. 20, 1993			
	7-7	Oct. 20, 1993			
	7-8	Nov. 12, 2001			
	7-9	Oct. 20, 1993			
	7-10	Dec. 30, 1994			
	7-11	Oct. 20, 1993			
	7-12	Dec. 30, 1994			
	7-13	Oct. 20, 1993			
	7-14	Oct. 20, 1993			
	7-15	Dec. 30, 1994			
	7-16	Oct. 20, 1993			

### RECORD OF REVISIONS

Any revisions to the present manual, with the exception of actual weighing data, must be recorded in the following table. Revisions of approved sections must be endorsed by the responsible airworthiness authority.

The new or amended text will be indicated by a bold black vertical line in the left hand margin of a revised page. Revision No. and reference will be shown on the bottom left hand corner of the page. The airplane may only be operated if the Flight Manual is up to date.

Rev. No.	Chapter	Pages	Date of Amendment	Approval Remarks	Date of Approval by Authority	Date inserted	Signature / Initials
1	0	0-4 thru 0-6	Dec. 30, 1994	[approved by Ing. Josef Eisnecker for ACG]	Feb. 10, 1995	Feb 16, 1995	DAI
	1	1-6					
	2	2-4, 2-9					
	3	3-2					
	4	4-2, 4-8, 4-11, 4-12, 4-14					
	5	5-4, 5-8, 5-9, 5-12					
	6	6-2, 6-4, 6-5, 6-7, 6-10, 6-14 thru 6-18					
	7	7-10, 7-12, 7-15					
2	0	0-4 thru 0-6	May 23, 1995	[approved by Ing. Josef Eisnecker for ACG]	July 28, 1995	Aug 21, 1995	DAI
	8	8-2					
3	0	0-4 thru 0-6	Nov. 12, 2001		13. Nov. 2001	Nov 23, 2001	Thomas Krasnik
	7	7-8					

Revision No. 3	Reference MSB20-39	Date November 12, 2001	Page 0 - 6
-------------------	-----------------------	---------------------------	---------------

Rev. No.	Chapter	Pages	Date of Amendment	Approval Remarks	Date of Approval by Authority	Date of Issue	Signature / Initials

# CHAPTER 1

## GENERAL

1.1.	INTRODUCTION	1-1
1.2.	CERTIFICATION BASIS	1-2
1.3.	WARNINGS, CAUTIONS, AND NOTES	1-2
1.4.	THREE-VIEW-DRAWING OF AIRPLANE	1-3
1.5.	DIMENSIONS	1-4
1.6.	ENGINE	1-5
1.7.	PROPELLER	1-5
1.8.	FUEL	1-5
1.9.	LUBRICANT AND COOLANT	1-6
1.10.	MASS (WEIGHT)	1-8
1.11.	LIST OF ABBREVIATIONS	1-9
1.12.	CONVERSION FACTORS	1-14

### 1.1. INTRODUCTION

The Airplane Flight Manual has been prepared to provide pilots and instructors with information for the safe and efficient operation of this airplane.

This Manual includes the material required to be furnished to the pilot by JAR-VLA. It also contains supplemental data supplied by the airplane manufacturer which can be useful to the pilot.

The Flight Manual conforms to the actual version of the customer's airplane. Any optional equipment installed on request of the customer (COM, NAV, etc.) is not considered.

For the operation of optional equipment the Operation Manual of the respective vendor must be used.

For permissible accessories refer to the equipment list, Section 6.5.

Revision No.	Reference	Date	Page
		October 20, 1993	1 - 1



## 1.2. CERTIFICATION BASIS

The DV 20 has been approved by the Austrian Federal Office for Civil Aviation (BAZ) in accordance with the Joint Aviation Requirements for Very Light Airplane (JAR-VLA), issued April 26, 1990, including Amendment VLA/92/1.

Category of Airworthiness : Normal

Noise Certification Basis : ZLZV 700/86 § 14 (1) (Austrian requirements, in accordance with ICAO annex 16, chapter 10)

## 1.3. WARNINGS, CAUTIONS, AND NOTES

The following definitions apply to warnings, cautions, and notes used in the Flight Manual:

### WARNING

means that the non-observation of the corresponding procedure leads to an immediate or important degradation of the flight safety.

### CAUTION

means that the non-observation of the corresponding procedure leads to a minor or to a more or less long term degradation of flight safety.

### NOTE

draws the attention to any special item not directly related to safety but which is important or unusual.

Revision No.	Reference	Date	Page
		October 20, 1993	1 - 2

1.4. THREE-VIEW-DRAWING OF AIRPLANE

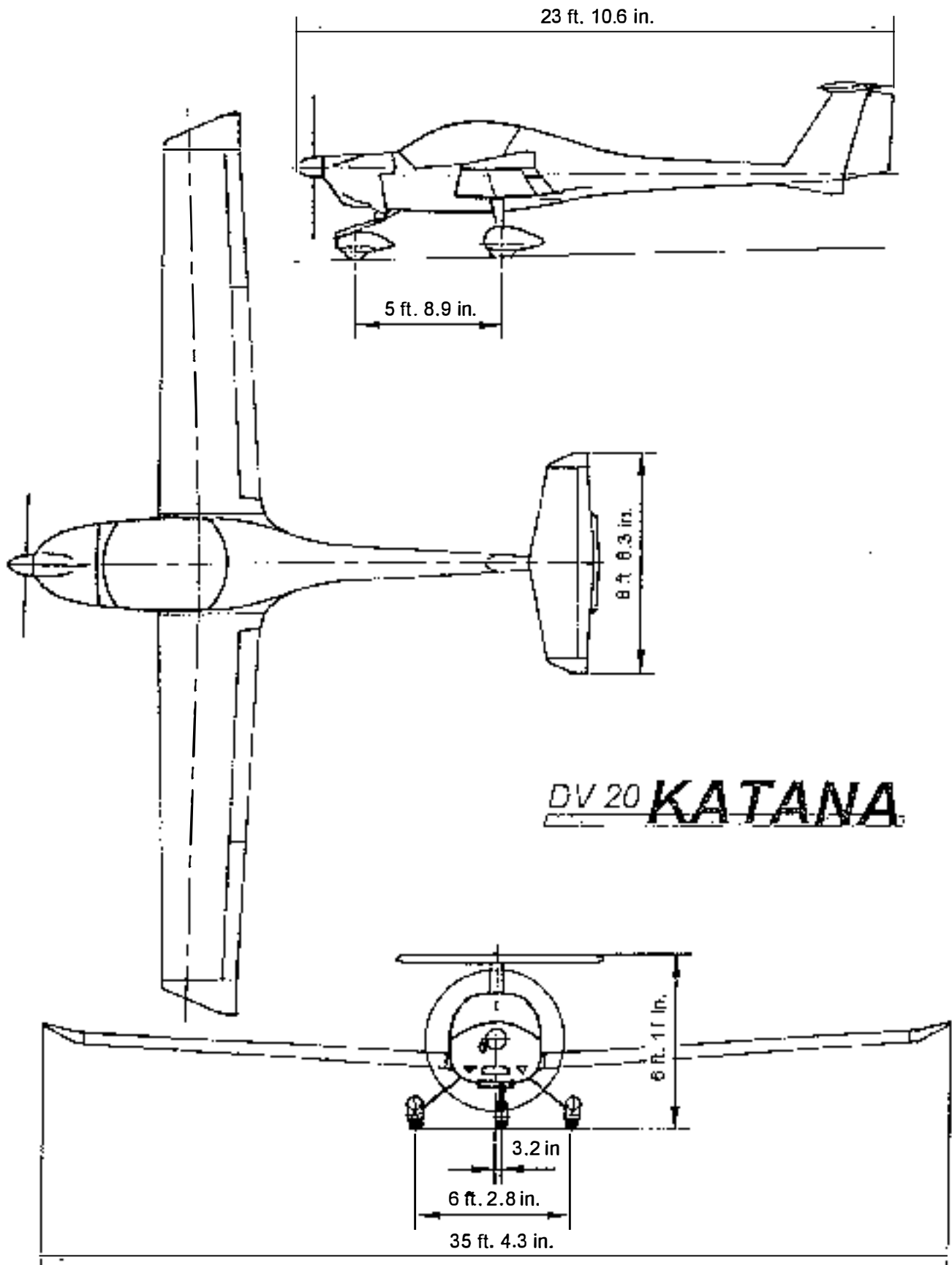

*DV 20* **KATANA**

## 1.5. DIMENSIONS

### OVERALL DIMENSIONS

Span without ACL	:	10.78 m (35 ft 4.3 in)
Span with ACL	:	10.84 m (35 ft 6.7 in)
Length	:	7.28 m (23 ft 10.6 in)
Width	:	1.76 m (5 ft 9.3 in)

### WINGS

Airfoil	:	Wortmann FX 63-137/20 HOAC
Wing area	:	11.6 m <sup>2</sup> (124.8 sq.ft.)
Mean aerodynamic chord (MAC)	:	1.09 m (3 ft 6.9 in)
Aspect Ratio	:	10.0
Dihedral	:	+4°
Sweep of Leading Edge	:	+1°

### AILERON

Area	:	0.658 m <sup>2</sup> (7.08 sq.ft.)
------	---	------------------------------------

### FLAPS

Area	:	1.236 m <sup>2</sup> (13.30 sq.ft.)
------	---	-------------------------------------

### HORIZONTAL STABILIZER

Area	:	1.692 m <sup>2</sup> (18.21 sq.ft.)
Elevator Area	:	0.441 m <sup>2</sup> (4.75 sq.ft.)
Angle of incidence	:	-2°

### VERTICAL STABILIZER

Area	:	1.134 m <sup>2</sup> (12.21 sq.ft.)
Rudder Area	:	0.426 m <sup>2</sup> (4.59 sq.ft.)

### LANDING GEAR

Track	:	1.90 m (6 ft 2.8 in)
Wheel base	:	1.75 m (5 ft 8.9 in)
Nose wheel	:	300*100/4.00-4
Main wheel	:	380*150/15*6.00-5

## 1.6. ENGINE

Rotax 912 A3, 4 Cylinder, 4 Stroke-Engine, horizontally opposed, liquid cooled cylinder heads, air-cooled cylinders.

Propeller drive via integrated reduction gear.

REDUCTION RATIO:	2.2727 : 1
DISPLACEMENT:	1.211 liters (73.9 cu.in.)
OUTPUT POWER:	59.6 kW / 80 hp
AT:	5800 RPM

## 1.7. PROPELLER

Two-bladed variable pitch propeller, manufactured by HOFFMANN, model HO-V72F/S170DW  
Constant speed, hydraulic pitch control

or

two-bladed variable pitch propeller, manufactured by HOFFMANN, model HO-V352F/170FQ  
Constant speed, hydraulic pitch control

RANGE OF PITCH ANGLE:	10° - 35°
DIAMETER:	1.70 m (5 ft 6.9 in)

## 1.8. FUEL

Approved fuel grades:

- a) AVGAS 100LL
- b) MOGAS in accordance with BAZ-Regulation ZI. 6412-11/16-83
- c) Automotive fuel, ROZ minimum 95 octane,  
leaded or unleaded

TOTAL CAPACITY:	79 liters (20.9 US gal.)
USABLE CAPACITY:	77 liters (20.3 US gal.)

Revision No.	Reference	Date	Page
		October 20, 1993	1 - 5

## 1.9. LUBRICANT AND COOLANT

### 1.9.1. Lubricant

Use only name-brand oil marked "SF" or "SG" in accordance with the API-System. The viscosity should be selected according to the various climatic conditions using the following table.

Avoid using single grade oils.

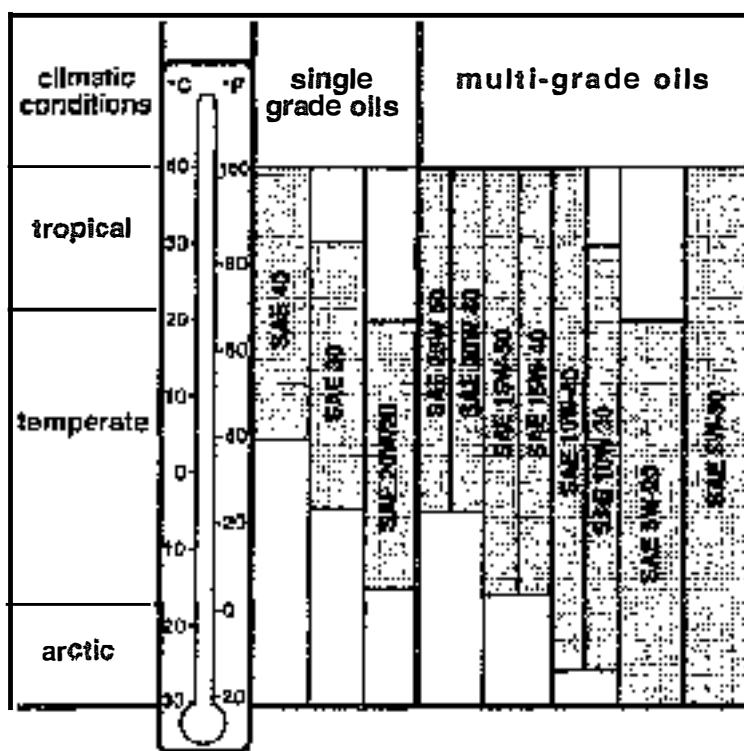

### CAUTION

Do not use aviation lubricant!

Oil Capacity:

Minimum : 2.0 liters (2.1 US qt.)

Maximum : 3.0 liters (3.2 US qt.)

Revision No. 1	Reference	Date December 30, 1994	Page 1 - 6
-------------------	-----------	---------------------------	---------------

## 1.9.2. COOLANT

Antifreeze concentrate with additives against corrosion should be used with approx. 20 % water added.

### CAUTION

Usage of lower quality coolants may result in sediments within the cooling system, degrading the efficiency of the system.

#### Coolant Capacity:

Minimum : 2.4 liters (2.5 US qt.)

Maximum : 2.5 liters (2.6 US qt.)

#### Reservoir Capacity:

Minimum : 0.1 liters (0.11 US qt.)

Maximum : 0.2 liters (0.21 US qt.)

### NOTE

The level in the reservoir can be checked using the coolant dipstick. Excessive overfilling of the reservoir can result in overflow during operation.

In the event of a completely empty reservoir, the coolant level in the dispatcher vessel on top of the engine must also be checked.

Revision No.	Reference	Date October 20, 1993	Page 1 - 7
--------------	-----------	--------------------------	---------------

## 1.10. MASS (WEIGHT)

Maximum take-off mass (weight)	: 730 kg (1609 lbs)
Maximum landing mass (weight)	: 730 kg (1609 lbs)
Empty mass (weight)	: See Chapter 6
Maximum mass (weight) in baggage compartment	: 20 kg (44 lbs)
Maximum useful load (including fuel)	: See Chapter 6

## WING LOADING

At maximum take-off mass (weight)	: 62.80 kg/m <sup>2</sup> (3.92 lbs/sq.ft.)
Performance load at max take-off mass (weight)	: 12.24 kg/kW (20.1 lbs/hp)

## 1.11. LIST OF ABBREVIATIONS

### a) Speed

**CAS:** Calibrated airspeed; Indicated speed corrected for installation and instrument errors. CAS is equal to TAS at standard atmospheric conditions at MSL.

**KCAS:** CAS in knots.

**IAS:** Indicated airspeed as shown on the airspeed indicator.

**KIAS:** IAS indicated in knots.

**GS:** Ground Speed. Speed of the airplane relative to the ground.

**TAS:** True airspeed. Speed of the airplane relative to air. TAS is CAS corrected for altitude and temperature errors.

**$v_A$ :** Maneuvering speed. Maximum speed at which the airplane is not overstressed at full deflection of control surfaces.

**$v_{FE}$ :** Maximum speed with flaps extended.

**$v_{NE}$ :** Speed which must never be exceeded in any operation.

**$v_{NO}$ :** Maximum structural cruising speed which should only be exceeded in calm air, and then only with caution.

Revision No.	Reference	Date October 20, 1993	Page 1 - 9
--------------	-----------	--------------------------	---------------



$v_S$ : The power-off stall speed with the airplane in its current configuration.

$v_{SO}$ : The power-off stall speed with the airplane in landing configuration.

$v_X$ : Best angle-of-climb speed.

$v_Y$ : Best rate-of-climb speed.

#### b) Meteorological Terms

ISA: International Standard Atmosphere at which air is identified as dry gas. The temperature at mean sea level is 15 °C (59 °F), the air pressure at sea level is 1013.25 mbar (29.92 inHg), the temperature gradient up to the altitude at which the temperature reaches -55.5 °C (-67.9 °F) is -0.0065 °C/m (-0.0036 °F/ft) and 0 °C/m (0 °F/ft) above.

OAT: Outside air temperature.

Indicated Pressure Altitude:

Altitude reading with altimeter set to 1013.25 mbar (29.92 inHg) air pressure.

Pressure Altitude:

Altitude measured at standard pressure at MSL (1013.25 mbar / 29.92 inHg) using a barometric altimeter. Pressure altitude is the indicated altitude corrected for installation and instrument errors. Within this manual the instrument errors are assumed to be zero.

Aerodrome Pressure:

Actual atmospheric pressure at the aerodrome altitude.

Revision No.	Reference	Date October 20, 1993	Page 1 - 10
--------------	-----------	--------------------------	----------------

Wind: The wind speeds used in the diagrams in this manual should be referred to as headwind or tail wind components of the measured wind.

**c) Powerplant**

Take-off Power:

Maximum engine power for take-off.

Maximum Continuous Power:

Maximum permissible continuous engine output power during flight.

**d) Flight Performance and Flight Planning**

Demonstrated crosswind component:

The max. speed of the crosswind component at which the maneuverability of the airplane during take-off and landing has been demonstrated during type certification test flights.

Service ceiling:

The altitude at which the maximum rate of climb is 0.5 m/s (100 ft/min).

**e) Mass and Center of Gravity****Reference Datum (RD):**

An imaginary vertical plane from which all horizontal distances for the center of gravity calculations are measured. It is the plane through the leading edge of the wing root rib, perpendicular to the longitudinal axis of the airplane.

**Station:**

A defined point along the longitudinal axis which is generally presented as a specific distance from the reference datum.

**Lever Arm:**

The horizontal distance from the reference datum to the center of gravity (of a component).

**Moment:**

The mass (weight) of a component multiplied by its lever arm.

**Center of Gravity:**

Point of equilibrium for the airplane mass.

**Center of Gravity Arm (CG position):**

Distance from the reference datum to the CG. It is determined by dividing the total moment (sum of the individual moments) by the total mass (weight).

**Center of Gravity Limits:**

The CG range which an airplane with a given mass must be operated within.

**Usable Fuel:**

The amount of fuel available for the flight plan calculation.

Revision No.	Reference	Date	Page
		October 20, 1993	1 - 12

**Unusable Fuel:**

The amount of fuel remaining in the tank, determined in accordance with to the requirements of the certification specifications.

**Empty Mass (Weight):**

Mass (Weight) of the airplane including unusable fuel, all operating fluids and maximum oil amount.

**Useful Load:**

The difference between take-off mass (weight) and empty mass (weight).

**Maximum take-off mass (weight):**

Maximum mass (weight) permissible for take-off.

**f) Equipment**

ACL: Anti Collision Light

Revision No.	Reference	Date October 20, 1993	Page 1 - 13
--------------	-----------	--------------------------	----------------

## 1.12. CONVERSION FACTORS

### LENGTH OR ALTITUDE

$$1 \text{ [ft.]} = 0.3048 \text{ [m]}$$

$$1 \text{ [in.]} = 25.4 \text{ [mm]}$$

### SPEED

$$1 \text{ [kts.]} = 1.852 \text{ [km/h]}$$

$$1 \text{ [mph]} = 1.609 \text{ [km/h]}$$

### PRESSURE

$$1 \text{ [hPa]} = 100 \text{ [N/m}^2\text{]} = 1 \text{ [mbar]}$$

$$1 \text{ [in. Hg]} = 33.865 \text{ [hPa]}$$

$$1 \text{ [psi]} = 68.97 \text{ [mbar]}$$

## CHAPTER 2

### OPERATING LIMITATIONS

2.1.	INTRODUCTION	2-1
2.2.	AIRSPED LIMITATIONS	2-2
2.3.	AIRSPED INDICATOR MARKINGS	2-3
2.4.	POWERPLANT LIMITATIONS	2-4
2.5.	POWERPLANT INSTRUMENT MARKINGS	2-6
2.6.	MISCELLANEOUS INSTRUMENT MARKINGS	2-6
2.7.	MASS (WEIGHT)	2-6
2.8.	CENTER OF GRAVITY	2-7
2.9.	PERMISSIBLE MANEUVERS	2-8
2.10.	MANEUVERING LOAD FACTORS	2-8
2.11.	SERVICE CEILING	2-9
2.12.	FLIGHT CREW	2-9
2.13.	KINDS OF OPERATION	2-9
2.14.	FUEL	2-9
2.15.	LIMITATION PLACARDS	2-10
2.16.	DEMONSTRATED CROSSWIND COMPONENT	2-10

#### 2.1. INTRODUCTION

Chapter 2 of this Flight Manual comprises the operating limitations, instrument markings, airspeed indicator markings, and the limitation placards which are necessary for the safe operation of the airplane, its engine, and standard systems and equipment.

The operating limitations in this Chapter and Chapter 9 have been approved by the Federal Office for Civil Aviation (BAZ).

#### WARNING

These limitations must be complied with for all operations.

Revision No.	Reference	Date	Page
		October 20, 1993	2 - 1

## 2.2. AIRSPEED LIMITATIONS

Speed	IAS			Remarks
	fts	mph	km/h	
V <sub>A</sub> Maneuvering speed	104	120	193	Do not make full or abrupt control movement above this speed, because under certain conditions the airplane may be overstressed by full control movement.
V <sub>FE</sub> Maximum Flap Extended speed	81	93	150	Do not exceed this speed with flaps extended
V <sub>NO</sub> Maximum structural cruising speed	117	135	217	Do not exceed this speed except in smooth air, and then only with caution
V <sub>NE</sub> Never exceed speed	161	185	298	Do not exceed this speed in any operation

### 2.3. AIRSPEED INDICATOR MARKINGS

Marking	IAS			Explanation
	kts.	mph	km/h	
White Arc	38-81	44-93	70-150	Operating range with extended flaps
Green Arc	43-117	49-135	80-217	Normal Operating Range
Yellow Arc	117-161	135-185	217-298	Maneuvers must be conducted with caution and only in smooth air.
Red Line	161	185	298	Maximum permissible speed for all operating modes



## 2.4. POWER PLANT LIMITATIONS

### 2.4.1. Engine

- (a) **Engine Manufacturer** : Bombardier Rotax, Gunskirchen/Austria  
(b) **Engine Type Designation** : 912 A3

### NOTE

The propeller is driven by the engine via a reduction gear with a ratio of 2.2727:1. The RPM indicator indicates the propeller speed. For that reason, all speed references within this manual - contrary to the engine manual - are propeller speeds.

#### (c) Engine Operating Limitations

Max T/O Power (5 min.) : 59.6 kW / 80 hp

Max. Permissible T/O RPM : 2550 RPM

Max. Continuous Power : 58 kW / 78 hp

Max. Permissible Continuous RPM : 2420 RPM

Idle Speed : 650 - 850 RPM

#### (d) Oil Pressure

Minimum : 1.5 bar (22 psi)

Maximum : 5.0 bar (73 psi)

Max. in case of Cold-start (short-term) : 7.0 bar (102 psi)

#### (e) Fuel Pressure

Minimum : 0.15 bar (2 psi)

Maximum : 0.40 bar (6 psi)

#### (f) Oil Temperature

Minimum : 50 °C (122 °F)

Maximum : 140 °C (284 °F)

Revision No.	Reference	Date	Page
1		December 30, 1994	2 - 4

- g) Cylinder Head Temperature  
Maximum : 150 °C (302 °F)
- h) Fuel Specifications:  
Approved Fuel Grades  
AVGAS 100LL  
MOGAS accord. to BAZ-Regulation ZI. 6412-11/16-83  
Automotive Fuel, ROZ minimum 95 octane,  
leaded or unleaded
- i) Oil Grades : Name-Brand Automotive Oil (also see Page 1-6)
- j) Propeller Manufacturer : Hoffmann Propeller, Rosenheim/Germany
- k) Propeller Type : HO-V72F/S 170 DW or  
HO-V352F/170FQ
- l) Propeller Diameter : 1.70 m (5 ft 6.9 in)
- m) Propeller Pitch (at 0.75\*R) : 10° - 35°
- n) Propeller Speed Limitations  
max T/O RPM (max. 5 min.) : 2550 RPM  
Max. Continuous RPM : 2420 RPM

## 2.5. POWERPLANT INSTRUMENT MARKINGS

Powerplant instrument markings and their color code significance are shown below:

Instrument	Red Line = Lower Limit	Green Arc = Normal Operating Range	Yellow Arc = Caution Range	Red Line = Upper Limit
Tachometer	-	950 - 2420 RPM	2420 - 2550 RPM	2550 RPM
Oil temperature indicator	50 °C (122 °F)	50 - 140 °C (122 - 284 °F)	-	140 °C (284 °F)
Cylinder head temperature indicator	-	-	-	150 °C (302 °F)
Oil Pressure Indicator	1.5 bar (22 psi)	1.5 - 5 bar (22 - 73 psi)	5 - 7 bar (73 - 102 psi)	7 bar (102 psi)
Fuel Quantity Indicator	-	-	-	-
Manifold Pressure Indicator	-	-	-	-

## 2.6. MISCELLANEOUS INSTRUMENT MARKINGS

[None.]

## 2.7. MASS (WEIGHT)

Maximum permissible take-off mass (weight)	: 730 kg (1609 lbs)
Maximum permissible landing mass (weight)	: 730 kg (1609 lbs)
Maximum permissible mass (weight) in the baggage compartment	: 20 kg (44 lbs) only permissible with baggage harness
Maximum useful load (incl. fuel)	: see weighing report (Ch. 6-4 f)
Maximum useful load on the left seat	: 110 kg (242 lbs)
Maximum useful load on the right seat	: 110 kg (242 lbs)

Revision No.	Reference	Date October 20, 1993	Page 2 - 6
--------------	-----------	--------------------------	---------------

## WARNING

Exceeding the mass (weight) limitations may lead to overloading of the airplane, as well as degrading of the handling characteristics and flight performance.

### 2.8. CENTER OF GRAVITY

The reference datum (RD) for the center of gravity (CG) calculation is tangent to the leading edge of the wing at the root rib. This plane is vertical when the fuselage is horizontal. Procedures for horizontal alignment, as well as particulars with regard to the empty mass center of gravity, refer to Chapter 6.

Most forward CG : 250 mm (9.84 in) aft of RD  
Most rearward CG : 390 mm (15.35 in) aft of RD

## WARNING

Exceeding the center of gravity limitations reduces the maneuverability and stability of the airplane.

The procedure used to determine the center of gravity is described in Chapter 6.

Revision No.	Reference	Date	Page
		October 20, 1993	2 - 7

## 2.9. APPROVED MANEUVERS

This airplane is certified in the Normal Category in accordance with JAR-VLA.

Permissible Maneuvers:

- a) All normal flight maneuvers
- b) Stalls (except dynamic stalls)
- c) Lazy Eights                      Entry speed: 116 kts (215 km/h)  
Chandelles:                      Entry speed: 116 kts (215 km/h)  
Steep turns in which the angle of bank does not exceed 60°

### NOTE

Aerobatics as well as flight maneuvers with bank angles of more than 60° are prohibited.

## 2.10. MANEUVERING LOAD FACTORS

Table of structural maximum permissible load factors:

	at $v_A$ :	at $v_{NE}$ :	with fully extended flaps
Positive	4.4	4.4	2.0
Negative	- 2.2	- 2.2	0

### WARNING

Any exceeding of the maximum load factors will result in overstressing of the airplane.

Simultaneous full deflection of more than one control surface will result in overstressing of the structure, even at speeds below the maneuvering speed.

Revision No.	Reference	Date October 20, 1993	Page 2 - 8
--------------	-----------	--------------------------	---------------

## 2.11. SERVICE CEILING

The airplane has a service ceiling of 4000 meters (13120 ft.).

## 2.12. FLIGHT CREW

Minimum flight crew: 1 Pilot, left seat should be occupied.

## 2.13. KINDS OF OPERATION

Flights are only permissible in accordance with visual flight rules and only during day (DAY-VFR).

Minimum Equipment, Flight and Navigation Instruments:

- Airspeed Indicator
- Altimeter
- Magnetic Compass

Minimum Equipment, Powerplant Instruments:

- Fuel Quantity indicator
- Oil Pressure indicator
- Oil Temperature indicator
- Manifold Pressure indicator
- Cylinder Head Temperature indicator
- Tachometer
- Fuel Pressure warning light
- Low-Voltage caution light
- Generator warning light

## 2.14. FUEL

Fuel Capacity

Total fuel quantity: : 79 liters (20.9 US gal.)  
Usable Fuel: : 77 liters (20.3 US gal.)

Approved Fuel Grades : see Section 2.4

Revision No.	Reference	Date	Page
1		December 30, 1994	2 - 9

## 2.15. LIMITATION PLACARDS

The following limitation placards must be installed:

(a) At the top of the left instrument panel:

**Maneuvering speed:  $v_A = 104$  kts.**

**This aeroplane is classified as a very light aeroplane approved for day VFR only, in non-icing conditions. All aerobatic maneuvers including intentional spinning are prohibited. See Flight Manual for other limitations.**

**No smoking!**

(b) In the baggage compartment:

**Baggage, max. 20 kg (44 lbs.),  
only with baggage harness**

### NOTE

For further placards refer to the Maintenance Manual, Doc. No. 4.02.02.

## 2.16. DEMONSTRATED CROSSWIND COMPONENT

The maximum demonstrated crosswind component is 15 kts. (27 km/h).

Revision No.	Reference	Date	Page
		October 20, 1993	2 - 10

## CHAPTER 3

# EMERGENCY PROCEDURES

<b>3.1.</b>	<b>INTRODUCTION</b>	<b>3-2</b>
<b>3.2.</b>	<b>AIRSPEEDS DURING EMERGENCY PROCEDURES</b>	<b>3-2</b>
<b>3.3.</b>	<b>EMERGENCY PROCEDURES - CHECKLISTS</b>	
<b>3.3.1.</b>	<b>Engine Failures</b>	
	<b>(a) Engine Failure During Take-off Run</b>	<b>3-3</b>
	<b>(b) Engine Failure After Take-off</b>	
	I. Insufficient Engine Power	3-3
	II. Engine Inoperative	3-4
	<b>(c) Engine Failure During Flight</b>	
	I. Engine Running Roughly	3-4
	II. Loss Of Oil Pressure	3-4
	III. Loss Of Fuel Pressure	3-4
	IV. Restarting The Engine With Propeller Windmilling	3-5
	V. Restarting The Engine With Propeller At Full Stop	3-5
<b>3.3.2.</b>	<b>Emergency Landing</b>	
	<b>(a) Emergency Landing With Engine Off</b>	<b>3-7</b>
	<b>(b) Precautionary Landing</b>	<b>3-7</b>
<b>3.3.3.</b>	<b>Fire</b>	
	<b>(a) Engine Fire During Start On The Ground</b>	<b>3-9</b>
	<b>(b) Engine Fire During Flight</b>	<b>3-9</b>
	<b>(c) Electrical Fire Including Smoke During Flight</b>	<b>3-9</b>
	<b>(d) Electrical Fire Including Smoke On The Ground</b>	<b>3-10</b>
	<b>(e) Cabin Fire During Flight</b>	<b>3-10</b>
<b>3.3.4.</b>	<b>Icing</b>	
	<b>(a) Unintentional Flight Into Icing Area</b>	<b>3-11</b>
<b>3.3.5.</b>	<b>Recovery From Unintentional Spin</b>	<b>3-12</b>
<b>3.3.6.</b>	<b>Landing With Defective Tire On Main Landing Gear</b>	<b>3-13</b>
<b>3.3.7.</b>	<b>Landing With Defective Wheel Brakes</b>	<b>3-13</b>
<b>3.3.8.</b>	<b>Gliding</b>	<b>3-14</b>
<b>3.3.9.</b>	<b>Electrical Power Failure</b>	
	<b>(a) Generator Warning Light Illuminated With Engine Running</b>	<b>3-14</b>
	<b>(b) Low Voltage Caution Light (Lo/V-Caution Light)</b>	<b>3-15</b>
<b>3.3.10</b>	<b>Flap System Failure</b>	<b>3-16</b>
<b>3.3.11</b>	<b>Starter Failure</b>	<b>3-16</b>
<b>3.3.12.</b>	<b>Avionics System Failure</b>	<b>3-17</b>



### 3.1. INTRODUCTION

The following chapter contains check-lists as well as descriptions of the recommended procedures in case of an emergency. However, engine failure or other airplane related emergency situations will most likely never occur if the mandatory preflight check and maintenance are performed properly.

In the event that an emergency situation does appear, the procedures presented in this manual should be used to rectify such problems. Since it is impossible to present in the Flight Manual all emergency situations which may occur, knowledge of the airplane and experience of the pilot are essential in rectifying such problems.

### 3.2. AIRSPEEDS DURING EMERGENCY PROCEDURES

		VIAS		
		kts	mph	km/h
Engine failure after take-off with flaps in T/O position		59	68	110
Maneuvering Speed		104	120	193
Airspeed for best glide ratio	730 kg (1609 lbs)	70	81	130
(Flaps in T/O-Position for all flight masses/weights)	600 kg (1323 lbs)	64	73	118
Precautionary Landing (with power and flaps in landing configuration)		54	62	100
Emergency landing with engine off (flaps as required)		59	68	110

### 3.3. EMERGENCY PROCEDURES - CHECKLISTS

#### 3.3.1. Engine Failures

##### (a) ENGINE FAILURE DURING TAKE-OFF RUN

- |    |          |             |
|----|----------|-------------|
| 1. | Throttle | IDLE        |
| 2. | Brakes   | as required |

##### (b) ENGINE FAILURE AFTER TAKE-OFF

##### I. INSUFFICIENT ENGINE POWER

- |    |                               |                             |
|----|-------------------------------|-----------------------------|
| 1. | Airspeed (V <sub>IAS</sub> )  | 59 kts. / 68 mph / 110 km/h |
| 2. | Throttle                      | FULL                        |
| 3. | Carburetor Heat               | OFF                         |
| 4. | Choke                         | OFF                         |
| 5. | Fuel Shut-off Valve           | OPEN                        |
| 6. | Ignition Switch               | BOTH                        |
| 7. | Electric Fuel Pump            | ON                          |
| 8. | Propeller Speed Control Lever | max. RPM                    |

### WARNING

If the engine performance cannot be restored immediately, the airplane should be landed.

Shortly before landing:

- |     |                         |        |
|-----|-------------------------|--------|
| 9.  | Fuel Shut-off Valve     | CLOSED |
| 10. | Ignition Switch         | OFF    |
| 11. | Master Switch (Battery) | OFF    |

## II. ENGINE INOPERATIVE

Perform emergency landing according to paragraph 3.3.2.

## (c) ENGINE FAILURE DURING FLIGHT

## I. ENGINE RUNNING ROUGHLY

- |    |                    |  |
|----|--------------------|--|
| 1. | Carburetor Heat    | ON   |
| 2. | Electric Fuel Pump | ON   |
| 3. | Magnetos           | check BOTH   |
| 4. | Throttle           | at present position  |
| 5. | No Improvement     | reduce throttle to minimum<br>required power, land as soon<br>as possible. |

## II. LOSS OF OIL PRESSURE

- |    |  |   |
|----|--|---|
| 1. | Oil Temperature  | check   |
| 2. | If oil pressure drops below green arc but<br>oil temperature is normal | land at nearest airfield  |
|    | If oil pressure drops below green arc and<br>oil temperature is rising | reduce throttle to minimum required<br>power;<br>land as soon as possible. Be prepared<br>for engine failure and emergency<br>landing |

## III. LOSS OF FUEL PRESSURE

- |    |   |   |
|----|---|---|
| 1. | Electric Fuel Pump                                    | ON  |
| 2. | If Fuel Pressure Warning Light<br>does not extinguish | Land as soon as possible. Be prepared<br>for engine failure and emergency<br>landing. |

## IV. RESTARTING THE ENGINE WITH PROPELLER WINDMILLING

As long as the airspeed ( $v_{IAS}$ ) is at least 54 kts. / 62 mph / 100 km/h, the propeller will continue to windmill.

- |    |                               |                             |
|----|-------------------------------|-----------------------------|
| 1. | Airspeed ( $v_{IAS}$ )        | 70 kts. / 81 mph / 130 km/h |
| 2. | Wing Flaps                    | T/O Position                |
| 3. | Propeller Speed Control Lever | max. RPM                    |
| 4. | Electric Fuel Pump            | ON                          |
| 5. | Ignition switch               | BOTH                        |
| 6. | Fuel Shut-off Valve           | OPEN                        |
| 7. | Throttle                      | 2 cm (3/4 in) forward       |

If the engine does not start within 10 seconds: Cold Start

- |     |                 |             |
|-----|-----------------|-------------|
| 8.  | Throttle        | IDLE        |
| 9.  | Choke           | ON (Pulled) |
| 10. | Ignition Switch | START       |

## V. RESTARTING THE ENGINE WITH PROPELLER AT FULL STOP

- |    |                               |   |
|----|-------------------------------|---|
| 1. | Electric Consumers            | OFF   |
| 2. | Master Switch (Battery)       | ON  |
| 3. | Propeller Speed Control Lever | max. RPM  |
| 4. | Electric Fuel Pump            | ON  |
| 5. | Throttle                      | Cold Start: IDLE<br>Warm Start: 2 cm (3/4 in) forward |
| 6. | Choke                         | Cold Start: ON (pulled)<br>Warm Start: OFF            |
| 7. | Ignition Switch               | START   |

**NOTE**

The engine may also be re-started by increasing the airspeed by pushing the airplane into a descent and accelerating to approx. 108 kts (124 mph / 200 km/h). A loss of 1000 ft / 300 m altitude must be taken into account.

After successful re-start:

- |     |                    |                |
|-----|--------------------|----------------|
| 8.  | Oil Pressure       | check          |
| 9.  | Choke              | OFF            |
| 10. | Electric Consumers | ON if required |
| 11. | Oil Temperature    | check          |

### 3.3.2. Emergency Landing

(a) EMERGENCY LANDING WITH ENGINE OFF

- |    |   |                             |
|----|---|-----------------------------|
| 1. | Airspeed ( $V_{IAS}$ )<br>(Flaps as required) | 59 kts. / 68 mph / 110 km/h |
| 2. | Fuel Shut-off Valve                           | CLOSED                      |
| 3. | Ignition Switch                               | OFF                         |
| 4. | Master Switch (Battery)                       | OFF                         |

(b) PRECAUTIONARY LANDING

#### NOTE

Such a landing would only be required if reasonable suspicion of a defect of the airplane or its systems raises doubts that the destination airfield can be reached without endangering the airplane or its occupants.

1. Search for a suitable place to land.  
Special attention must be given to wind direction and obstacles in the approach path
2. Initiate Descent
3. Throttle as required
4. Trim as required
5. Wing Flaps as required  
(observe permissible speed)

6. Low pass over flight (not below 350 ft / 100 m above ground) over selected landing area to observe any possible obstacles such as cables, fences, ditches, etc.
7. Final Approach.
8. Throttle as required
9. Propeller Speed Control Lever max RPM
10. Carburetor Heat ON
11. Electric Fuel Pump ON
12. Wing Flaps LDG
13. Airspeed ( $V_{IAS}$ ) 59 kts / 68 mph / 110 km/h
14. Touch-down is to be made with minimum airspeed, nose wheel should be kept above ground as long as possible
15. After touch-down:
 

Fuel Shut-off Valve	CLOSED
Ignition Switch	OFF
Master Switch (Battery)	OFF

### NOTE

If no suitable level landing area can be found, an up-hill landing should be preferred, if possible.

### 3.3.3. Fire

(a) ENGINE FIRE DURING START ON THE GROUND

- |    |                               |        |
|----|-------------------------------|--------|
| 1. | Fuel Shut-off Valve           | CLOSED |
| 2. | Throttle                      | FULL   |
| 3. | Master Switch (Battery)       | OFF    |
| 4. | Ignition Switch               | OFF    |
| 5. | Evacuate Airplane immediately |        |

(b) ENGINE FIRE DURING FLIGHT

- |    |  |                             |
|----|--|-----------------------------|
| 1. | Airspeed (V <sub>IAS</sub> )   | 70 kts. / 81 mph / 130 km/h |
| 2. | Flaps  | T/O                         |
| 3. | Fuel Shut-off Valve  | CLOSED                      |
| 4. | Throttle   | FULL                        |
| 5. | Electric Fuel Pump   | OFF                         |
| 6. | Cabin Heat   | CLOSED                      |
| 7. | Master Switch (Battery)  | OFF                         |
| 8. | Perform emergency landing with engine off according to paragraph 3.3.2 |                             |

(c) ELECTRICAL FIRE INCLUDING SMOKE DURING FLIGHT

- |    |                         |  |
|----|-------------------------|--|
| 1. | Master Switch (Battery) | OFF                                      |
| 2. | Cabin Heat              | CLOSED                                   |
| 3. | Cabin Air               | OPEN                                     |
| 4. | Fire Extinguisher       | use only if smoke development continues. |

### CAUTION

While fire extinguisher is used, the cabin must be aerated.



In case the fire is extinguished and electric power is required for continuation of the flight:

- |     |                           |     |
|-----|---------------------------|-----|
| 5.  | Avionics Master Switch    | OFF |
| 6.  | Electric Consumers        | OFF |
| 7.  | Master Switch (Battery)   | ON  |
| 8.  | Avionics Master Switch    | ON  |
| 9.  | Radio                     | ON  |
| 10. | Land as soon as possible. |     |

(d) ELECTRICAL FIRE INCLUDING SMOKE ON THE GROUND

- |    |               |     |
|----|---------------|-----|
| 1. | Master Switch | OFF |
|----|---------------|-----|

If engine running:

- |    |                      |                    |
|----|----------------------|--------------------|
| 2. | Throttle             | IDLE               |
| 3. | Fuel Shutt-off Valve | CLOSED             |
| 4. | Ignition Switch      | OFF                |
| 5. | Canopy               | open               |
| 6. | Fire Extinguisher    | employ as required |

(e) CABIN FIRE DURING FLIGHT.

- |    |                          |                    |
|----|--------------------------|--------------------|
| 1. | Master Switch (Battery)  | OFF                |
| 2. | Cabin Air                | OPEN               |
| 3. | Cabin Heat               | CLOSED             |
| 4. | Fire Extinguisher        | employ as required |
| 5. | Land as soon as possible |                    |

### 3.3.4. Icing

#### (a) UNINTENTIONAL FLIGHT INTO ICING AREA

1. Leave icing area (through change of altitude or change of flight direction to reach area with higher outside air temperature).
2. Continue to move control surfaces to maintain their movability.
3. Carburetor Heat ON
4. Increase RPM to avoid icing of propeller blades (observe maximum RPM)
5. Cabin Heat OPEN

#### CAUTION

In case of icing on the leading edge of the wing, the stall speed may increase.

Revision No.	Reference	Date October 20, 1993	Page 3 - 11
--------------	-----------	--------------------------	----------------

### 3.3.5. Recovery From Unintentional Spin

1. Throttle IDLE
2. Rudder fully engaged opposite to direction of spin
3. Control Stick neutral
4. Rudder neutral
5. Wing Flaps UP
6. Elevator pull cautiously

Bring airplane from descent into level flight position. Do not exceed maximum permissible speed ( $V_{NE}$ )

#### NOTE

Due to the excellent low-speed- and stability characteristics of the airplane, unintentional spin is unduly to occur during climb, level flight, descent, or during banking as long as the airspeed does not drop below the minimum permissible speed and the center of gravity is within its limits.



**3.3.8. Gliding**

- |    |   |  |
|----|---|--|
| 1. | Wing Flaps  | T/O  |
| 2. | Airspeed at 730 kg (1609 lbs)<br>at 600 kg (1323 lbs)   | (V <sub>IAS</sub> ) 70 kts/ 81 mph/ 130 km/h<br>(V <sub>IAS</sub> ) 64 kts/ 73 mph/ 118 Km/h |
| 3. | Glide ratio 14, which means at<br>1000 ft/305m above ground, and with<br>no wind the distance of glide is<br>4.3 km (2.5 NM). |  |

**NOTE**

The glide distance from 1000 ft altitude increases for each 10 kts tail wind by 0.6 km (1968 ft).

The glide distance from 1000 ft altitude decreases for each 10 kts head wind by 0.7 km (2296 ft).

**3.3.9. Electrical Power Failure****(a) Generator Warning Light Illuminated With Engine Running**

- |    |  |   |
|----|--|---|
| 1. | Ammeter<br>If needle on indicator is on left side of<br>0-marking (-): | check<br>Switch off all equipment not required<br>for a safe flight<br>Land on nearest available airfield |
|----|--|---|

**NOTE**

With average battery condition, safe operation of the radio and the extending of the landing flaps is possible for at least one hour.

**(b) Low Voltage Caution Light (Lo/V-Caution Light)**

This caution light illuminates if the on-board voltage (13.75V) drops below the threshold of 12.5 Volts.

Possible reason for voltage drop:

- Defective Power Supply
- RPM too low
- Operation of too many electrical consumers (equipment)

**I. LO/V-CAUTION LIGHT ILLUMINATED WHILE AIRPLANE ON GROUND**

- |    |  |  |
|----|--|--|
| 1. | RPM  | 1200 RPM                                 |
| 2. | Landing Lights   | OFF                                      |
| 3. | Position Lights  | OFF                                      |
| 4. | Ammeter  | check                                    |
| 5. | If the Lo/V-caution light continues to be illuminated, and the ammeter is in the left side field (-) | discontinue any planned flight activity. |

**II. LO/V-CAUTION LIGHT ILLUMINATED DURING FLIGHT:**

- |    |   |                              |
|----|---|------------------------------|
| 1. | Landing Lights  | OFF                          |
| 2. | Ammeter   | check                        |
| 3. | If the Lo/V-caution light continues to be illuminated, and the ammeter is in the left side field (-): Defective Generator | Refer to paragraph 3.3.9.(a) |

**III. LO/V-CAUTION LIGHT ILLUMINATED DURING LANDING:**

- |    |               |  |
|----|---------------|--|
| 1. | After Landing | proceed in accordance with paragraph 3.3.9.(b)l. |
|----|---------------|--|

### 3.3.10. Flap System Failure

#### Failure of Position Indication or Function

- visual check of the flap position
- select airspeed within the range of the white arc marked on the airspeed indicator
- check all positions of the flap toggle switch (flap stops are fail-safe)
- adapt approaching procedure to available flap position:
  - \* only UP available: - raise approach speed by 5 kts.
    - throttle as required
    - flat approach angle
  - \* only T/O available: - normal approach speed
    - throttle as required
    - flat approach angle
  - \* only LDG available: - normal landing

### 3.3.11. Starter Failure

Starter does not disengage after starting the engine.

1. Throttle IDLE
  2. Ignition Switch OFF
- discontinue any planned flight

### 3.3.12 Avionics System Failure

Radio system operative, no reception:

1. Microphone Key check for sticking
2. Speaker check, deactivate SQUELCH for a few moments, use headsets if available

Radio system operative, transmitting not possible:

1. Selected Frequency check if correct
2. Microphone check, if available use different one (headset)

Problem cannot be resolved:

switch transponder (if available) to "COMM FAILURE" code if required by the situation and permitted by applicable national regulations.



## CHAPTER 4

### NORMAL OPERATING PROCEDURES

4.1.	INTRODUCTION	4-1
4.2.	AIRSPEEDS FOR NORMAL FLIGHT OPERATION	4-2
4.3.	[INTENTIONALLY LEFT BLANK]	4-3
4.4.	NORMAL OPERATION CHECKLIST	4-5
4.4.1.	Preflight Inspection	
	I. In-Cabin Check	4-5
	II. Walk-Around Check	4-6
4.4.2.	Before Starting Engine	4-9
4.4.3.	Starting Engine	4-10
4.4.4.	Before Taxiing	4-11
4.4.5.	Taxiing	4-11
4.4.6.	Before Take-off	4-12
4.4.7.	Take-off	4-13
4.4.8.	Climb	4-14
4.4.9.	Cruise	4-14
4.4.10.	Descent	4-15
4.4.11.	Landing Approach	4-15
4.4.12.	Balked Landing	4-16
4.4.13.	After Landing	4-16
4.4.14.	Engine Shut-down	4-16
4.4.15.	After-Flight Check	4-17
4.4.16.	Flight in Rain	4-17

#### 4.1. INTRODUCTION

Chapter 4 provides checklist and amplified procedures for the normal operation. For normal procedures and supplementary information associated with optional systems refer to Chapter 9.

Revision No.	Reference	Date	Page
		October 20, 1993	4 - 1

## 4.2. AIRSPEEDS FOR NORMAL FLIGHT OPERATION

Unless stated otherwise, the following table contains the applicable airspeeds for maximum take-off and landing mass (weight). The airspeeds may also be used for lower flight masses.

TAKE-OFF	V <sub>IAS</sub>		
	kts	mph	km/h
Climb Speed during normal take-off for 15 m (50 ft) obstacle	58	67	108
Best Rate-of-Climb speed at sea level $v_y$ (flaps T/O)	65	75	120
Best Angle-of-Climb speed at sea level $v_x$ (flaps T/O)	58	67	108

LANDING	V <sub>IAS</sub>		
	kts	mph	km/h
Approach speed for normal landing. Flaps in landing position	59	68	110
Minimum speed for balked landing. Flaps in take-off or landing position	51	59	95
Maximum demonstrated crosswind speed during take-off and landing	15	17	27

CRUISE	V <sub>IAS</sub>		
	kts	mph	km/h
Maximum permissible speed in rough air $v_{NO}$	117	135	217
Maximum permissible speed with full control surface deflections $v_A$	104	120	193
Maximum permissible speed with wing flaps extended $v_{FE}$	81	93	150

INTENTIONALLY LEFT BLANK

Revision No.	Reference	Date	Page
		October 20, 1993	4 - 3

INTENTIONALLY LEFT BLANK

Revision No.	Reference	Date October 20, 1993	Page 4 - 4
--------------	-----------	--------------------------	---------------

## 4.4. NORMAL OPERATION CHECKLIST

### 4.4.1. Preflight Inspection

#### I. In-Cabin Check

(a)	Airplane Documents	check
(b)	Check List	present
(c)	Parking Brake	Set
(d)	Ignition Key	pulled out
(e)	Canopy	clean, undamaged
(f)	Circuit Breakers	pressed in
(g)	Master Switch (Battery)	ON
(h)	Fuel Quantity	sufficient
(i)	Master Switch (Battery)	OFF
(j)	Throttle	IDLE
(k)	Propeller Speed Control Lever	max RPM
(l)	Carburetor Heat	OFF
(m)	Foreign Object Inspection	done
(n)	Emergency Locator Transmitter (ELT)	AUTO
(o)	Main Bolts (see page 7-2)	secured
(p)	Baggage	stowed, baggage harness attached

II. WALK AROUND CHECK AND VISUAL INSPECTION

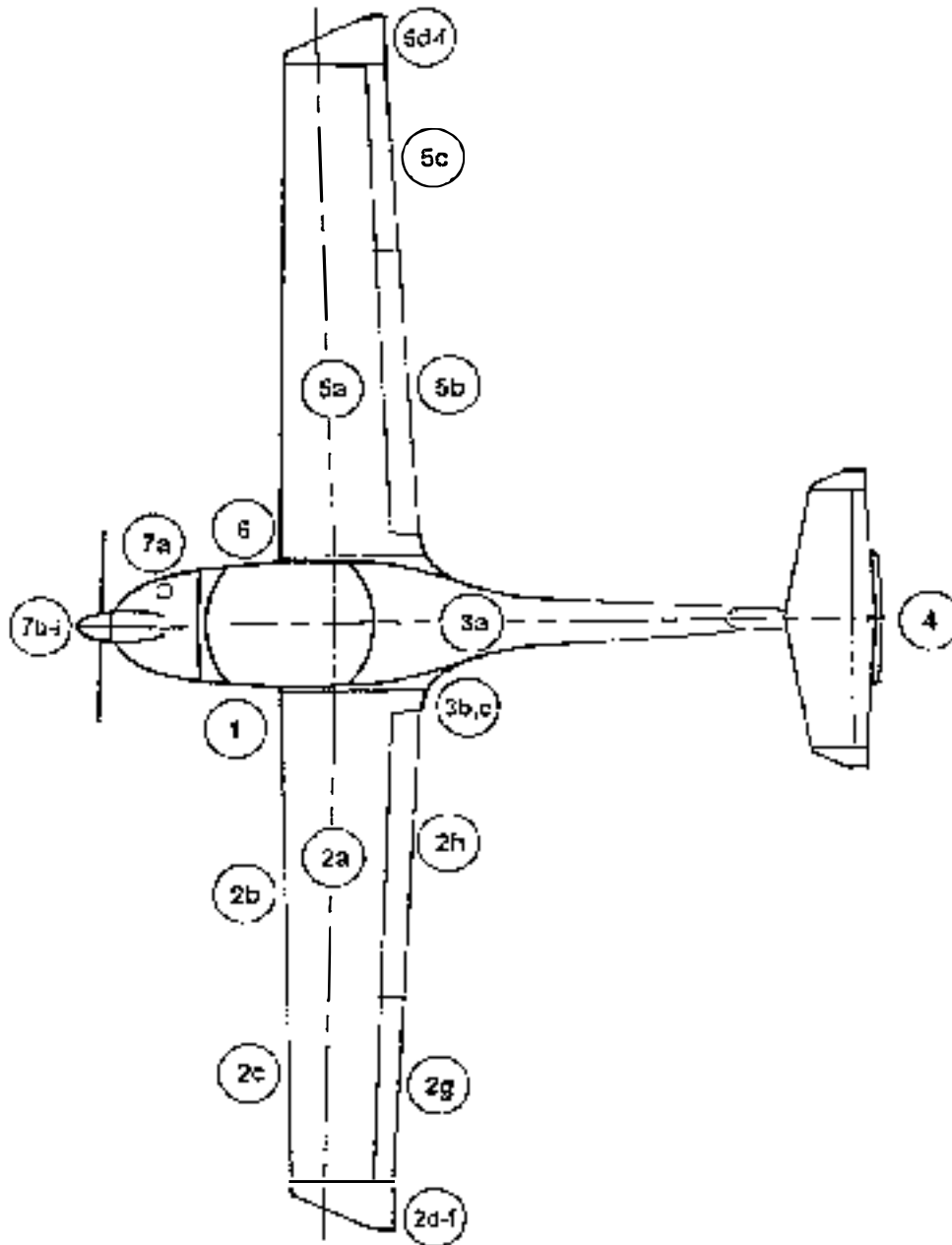

## CAUTION

Visual Inspection is defined as check for:

Defects, cracks, delaminations, excessive play, insecure or improper mounting, and general condition. Additionally, freedom of movement for control surfaces.

### 1. Left Main Landing Gear

- |    |                                  |                   |
|----|----------------------------------|-------------------|
| a) | Landing Gear Strut               | visual inspection |
| b) | Wheel Fairing                    | visual inspection |
| c) | Tire Pressure (2.3 bar / 33 psi) | check             |
| d) | Tire, Wheel, Brake               | visual inspection |
| e) | Skid Marks                       | visual inspection |

### 2. Left Wing

- |    |                             |                         |
|----|-----------------------------|-------------------------|
| a) | Entire Wing                 | visual inspection       |
| b) | Stall Warning               | check (suck on opening) |
| c) | Pitot-Static Probe          | clean, hole open        |
| d) | Wing Tip, Balancing Mass    | visual inspection       |
| e) | Position Light              | visual inspection       |
| f) | Mooring Harness on Wing Tip | release                 |
| g) | Aileron                     | visual inspection       |
| h) | Wing Flap                   | visual inspection       |

### 3. Fuselage

- |    |               |                         |
|----|---------------|-------------------------|
| a) | Skin          | visual inspection       |
| b) | Tank Vent     | check                   |
| c) | Tank drain    | drain water             |
| d) | Fuel Quantity | check with fuel pipette |

### 4. Empennage

- |    |                             |                   |
|----|-----------------------------|-------------------|
| a) | Fins and control surfaces   | visual inspection |
| b) | Mooring Harness on Tail Fin | release           |
| c) | Trim Tab                    | visual inspection |

## 5. Right Wing

- |    |                             |                   |
|----|-----------------------------|-------------------|
| a) | Entire Wing                 | visual inspection |
| b) | Wing Flap                   | visual inspection |
| c) | Aileron                     | visual inspection |
| d) | Mooring Harness on Wing Tip | release           |
| e) | Wing Tip, Balancing Mass    | visual inspection |
| f) | Position Light              | visual inspection |

## 6. Right Main Landing Gear

- |    |                                  |                   |
|----|----------------------------------|-------------------|
| a) | Landing Gear Strut               | visual inspection |
| b) | Wheel Fairing                    | visual inspection |
| c) | Tire Pressure (2.3 bar / 33 psi) | check             |
| d) | Tire, Wheel, Brake               | visual inspection |
| e) | Creep Marks                      | visual inspection |

## 7. Nose

- |    |                 |                       |
|----|-----------------|-----------------------|
| a) | - Oil Level     | check using dip-stick |
|    | - Coolant Level | check using dip-stick |

**NOTE**

Notable consumption of oil or coolant does normally not occur. It is therefore neither necessary nor sensible to refill before the level has dropped below the minimum marking.

- |    |                                  |  |
|----|----------------------------------|--|
| b) | Cowling                          | visual inspection  |
| c) | Air Intakes (six)                | free   |
| d) | Propeller                        | visual inspection, Ground Clearance; minimum: approx. 25 cm (10 in). |
| e) | Spinner                          | visual inspection  |
| f) | Nose Gear                        | visual inspection  |
| g) | Tire and Wheel                   | visual inspection  |
| h) | Wheel Fairing                    | visual inspection  |
| i) | Tire Pressure (1.8 bar / 26 psi) | check  |



**4.4.2. BEFORE STARTING ENGINE**

1.	Preflight Inspection	performed
2.	Pedals	adjust, lock
3.	Safety Belts	fasten
4.	Canopy	close and secure
5.	Parking Brake	set
6.	Controls	free
7.	Fuel Shut-off Valve	OPEN
8.	Trim	NEUTRAL
9.	Throttle	free, IDLE
10.	Prop. Speed Control Lever	free, max RPM
11.	Carburetor Heat	free, OFF
12.	Friction Device of Throttle Quadrant	adjust
13.	Avionics Master Switch	OFF
14.	Master Switch (Battery)	ON
15.	Generator Warning Light	illuminated
16.	Low Voltage Caution Light	illuminated
17.	Fuel Pressure Warning Light	illuminated.

**NOTE**

Under certain circumstances, activation of the fuel pressure warning light might take as long as 10 minutes after shutting down the engine or switching off the electric fuel pump.

**4.4.3. STARTING ENGINE**

- |    |  |  |
|----|--|--|
| 1. | Electric Fuel Pump                     | ON<br>(noise of pump audible)                  |
| 2. | Fuel Pressure Warning Light            | OFF  |
| 3. | Throttle - Cold Start<br>- Warm Engine | IDLE<br>approximately 2 cm (3/4<br>in) forward |
| 4. | Choke - Cold Start<br>- Warm Engine    | ON, fully pulled<br>OFF                        |

**WARNING**

Ensure people are clear of the propeller danger zone!

- |    |              |   |
|----|--------------|---|
| 5. | Ignition Key | START   |
| 6. | Throttle     | maximum 1500 RPM                                  |
| 7. | Oil Pressure | within green range after<br>maximum of 10 seconds |

**CAUTION**

If oil pressure is below 1.5 bar (22 psi) shut down engine immediately  
(10 seconds maximum delay)

- |     |                             |  |
|-----|-----------------------------|--|
| 8.  | Generator Warning Light     | OFF  |
| 9.  | Low Voltage Caution Light   | OFF  |
| 10. | Electric Fuel Pump          | OFF  |
| 11. | Fuel Pressure Warning Light | Might not illuminate (wait<br>for 10 sec.) |
| 12. | Electric Fuel Pump          | ON   |

#### 4.4.4. Before Taxiing

- |    |  |                                 |
|----|--|---------------------------------|
| 1. | Electric Consumers                         | ON as required                  |
| 2. | Powerplant Instruments                     | check                           |
| 3. | Wing Flaps (Indicator- and Flap Actuation) | check, extend and retract fully |
| 4. | Avionics Master Switch                     | ON                              |
| 5. | Flight Instruments and Avionics            | set                             |
| 6. | Parking Brake                              | release                         |

### CAUTION

Warm-up engine to a minimum oil temperature of 50 °C (122 °F) at 1100 to 1500 RPM (also possible during taxiing).

#### 4.4.5. Taxiing

- |    |                                 |       |
|----|---------------------------------|-------|
| 1. | Brake                           | check |
| 2. | Direction Control               | check |
| 3. | Flight Instruments and Avionics | check |

## 4.4.6. Before Take-off

- |     |                               |   |
|-----|-------------------------------|---|
| 1.  | Parking Brake                 | set   |
| 2.  | Safety Harnesses              | fastened  |
| 3.  | Canopy                        | closed and locked   |
| 4.  | Fuel Shut-off Valve           | check, OPEN   |
| 5.  | Powerplant Instruments        | within green range  |
| 6.  | Fuel Quantity Indicator       | check   |
| 7.  | Wing Flaps                    | T/O   |
| 8.  | Trim                          | NEUTRAL   |
| 9.  | Controls                      | free  |
| 10. | Throttle                      | 1700 RPM  |
| 11. | Propeller Speed Control Lever | Pull completely 3 times<br>(RPM drop: 100 - 200 RPM)                        |
| 12. | Ignition Switch               | L<br>R<br>BOTH<br>(Max RPM drop: 150 RPM<br>Max RPM difference L/R: 50 RPM) |
| 13. | Throttle                      | 1500 RPM  |
| 14. | Carburetor Heat               | OFF - ON<br>RPM drop: 30 RPM;<br>OFF  |
| 15. | Throttle                      | FULL for 5 sec., back to IDLE;<br>check RPM<br>(2450 RPM $\pm$ 100 RPM)     |
| 16. | Parking Brake                 | release   |

## 4.4.7. TAKE-OFF

- |    |                                    |                                  |
|----|------------------------------------|----------------------------------|
| 1. | Electric Fuel Pump                 | check, ON                        |
| 2. | Propeller Speed Control Lever      | max. RPM                         |
| 3. | Throttle                           | FULL<br>(2400 RPM $\pm$ 100 RPM) |
| 4. | Elevator - at beginning of rolling | NEUTRAL                          |
| 5. | Control direction                  | using rudder                     |

**NOTE**

In crosswind conditions, directional control can be enhanced by using the single wheel brakes. Note that using the brakes for directional control increases the take-off roll distance.

		V <sub>AS</sub>		
6.	Lift Nose wheel	51 kts.	59 mph	95 km/h
7.	Climb Speed	65 kts.	75 mph	120 km/h

**CAUTION**

For the shortest possible take-off distance to clear a 15 m (50 ft) obstacle:

Liftoff speed	57 kts / 65 mph / 105 km/h.
Climb Speed	58 kts / 67 mph / 108 km/h

- |    |                           |                                       |
|----|---------------------------|---------------------------------------|
| 8. | Prop. Speed Control Lever | 2400 RPM (after reaching safe height) |
| 9. | Electric Fuel Pump        | OFF                                   |

**NOTE**

In order to avoid excessive noise, the prop speed should be reduced to 2400 RPM as soon as a safe flight altitude has been reached.

## 4.4.8. Climb

1. Propeller Speed Control Lever 2400 RPM
2. Throttle FULL
3. Powerplant Instruments within green range
4. Flaps T/O (UP)
5. Airspeed 65 kts. / 75 mph / 120 km/h

**NOTE**

The best rate of climb speed decreases with increasing altitude.

	Flaps T/O			Flaps UP		
	kts.	mph	km/h	kts.	mph	km/h
0 - 4000 ft.	65	75	120	70	81	130
4000 - 7000 ft.	63	73	117	67	78	125
7000 - 10000 ft.	62	71	115	---	---	---
10000 ft.	59	68	110	---	---	---

6. Trim adjust

## 4.4.9. Cruise

1. Wing Flaps UP
2. Throttle as required
3. Propeller Speed Control Lever 1900 - 2400 RPM

**NOTE**

For favorable manifold pressure/RPM combinations refer to Chapter 5.

4. Trim as required

**CAUTION**

Max operating time of position lights: 50 % of flight time.

Revision No.	Reference	Date	Page
1		December 30, 1994	4 - 14

**4.4.10. DESCENT**

- |    |                          |                 |
|----|--------------------------|-----------------|
| 1. | Altimeter                | adjust          |
| 2. | Throttle                 | as required     |
| 3. | Prop Speed Control Lever | 1900 - 2400 RPM |
| 4. | Carburetor Heat          | as required     |

**CAUTION**

To achieve a fast descent:

Prop Speed Control Lever	2400 RPM
Throttle	IDLE
Carburetor Heat	ON
Wing Flaps	UP
Airspeed	117 kts./135 mph/217 km/h

**4.4.11. LANDING APPROACH**

- |    |                          |                                 |
|----|--------------------------|---------------------------------|
| 1. | Airspeed                 | max. 81 kts / 93 mph / 150 km/h |
| 2. | Wing Flaps               | T/O                             |
| 3. | Trim                     | as required                     |
| 4. | Throttle                 | as required                     |
| 5. | Prop Speed Control Lever | maximum RPM                     |
| 6. | Carburetor Heat          | ON                              |
| 7. | Electric Fuel Pump       | ON                              |
| 8. | Wing Flaps               | LDG                             |
| 9. | Approach Speed           | 60 kts / 68 mph / 110 km/h      |

**CAUTION**

Maximum operating time of landing light:  
10 % of flying time, but no longer than 5 minutes.

**NOTE**

Under conditions like strong headwind, danger of wind-shear or turbulence, a higher approach speed should be selected.

**4.4.12. BALKED LANDING**

1.	Prop Speed Control Lever	max RPM
2.	Throttle	FULL
3.	Carburetor Heat	OFF
4.	Wing Flaps	T/O
5.	Airspeed	58 kts / 67 mph / 108 km/h

**4.4.13. AFTER LANDING**

1.	Throttle	IDLE
2.	Wing Flaps	UP
3.	Carburetor Heat	OFF
4.	Landing Light	OFF

**4.4.14. ENGINE SHUT-DOWN**

1.	Throttle	IDLE
2.	Parking Brake	set
3.	Electric Fuel Pump	OFF
4.	Avionics Master Switch	OFF
5.	Ignition Switch	OFF
6.	Master Switch (Battery)	OFF

**NOTE**

In case of post ignition due to hot weather conditions and the use of MOGAS, the ignition should be switched on, choke pulled and after approximately 3 seconds, ignition should be turned off again.



**4.4.15. AFTER-FLIGHT CHECK**

1. ELT check if triggered

**4.4.16. FLIGHT IN RAIN****NOTE**

Flight performance might be reduced, especially for the T/O-distance and the maximum horizontal air speed. The influence on flight characteristics of the airplane is negligible. Flights through heavy rain should be avoided due to the reduced visibility.

Revision No.	Reference	Date October 20, 1993	Page 4 - 17
--------------	-----------	--------------------------	----------------

# CHAPTER 5

## PERFORMANCE

<b>5.1.</b>	<b>INTRODUCTION</b>	<b>5-1</b>
<b>5.2.</b>	<b>USE OF PERFORMANCE TABLES AND DIAGRAMS</b>	<b>5-2</b>
<b>5.3.</b>	<b>PERFORMANCE TABLES AND DIAGRAMS</b>	<b>5-3</b>
5.3.1.	Figure 5.1: Airspeed Calibration	5-3
5.3.2.	Figure 5.2: Cruising Performance	5-4
5.3.3.	Figure 5.3: Pressure Altitude - Density Altitude	5-5
5.3.4.	Figure 5.4: Stall Speeds	5-6
5.3.5.	Figure 5.5: Wind Data	5-7
5.3.6.	Figure 5.6: Take-Off Distances	5-8
5.3.7.	Figure 5.7: Climb Performance / Cruising Altitudes	5-9
5.3.8.	[Intentionally left blank.]	
5.3.9.	Figure 5.9: Cruising Speed (True Airspeed)	5-11
5.3.10.	Figure 5.10: Maximum Flight Duration	5-12
5.3.11.	Figure 5.11: Climb performance during balked landing	5-13
5.3.12.	Landing Distances	5-14
<b>5.4.</b>	<b>NOISE DATA</b>	<b>5-14</b>

### 5.1. INTRODUCTION

The performance tables and diagrams on the following pages have been prepared to illustrate the performance you may expect from your airplane as well as to enable you to conduct precise flight planning. The data presented in these tables and diagrams has been derived from test-flights using an airplane and engine in good operating condition, and was corrected to standard atmospheric conditions (IAS = 15 °C (59 °F) and 1013.25 mbar (29.92 in. Hg) at sea level).

The performance tables do not take into account the expertise of the pilot or the maintenance condition of the airplane. The performance illustrated in the tables can be achieved if the indicated procedures are followed and the airplane is in good maintenance condition.

Note that the range and flight duration data in each diagram includes a 30 minute fuel reserve for the indicated power level. The fuel consumption during cruise is based on propeller RPM and manifold pressure settings. Some undefined variables such as the operating condition of the engine, or turbulence could have influences on flight distance and flight duration. For this reason, it is of utmost importance that all available data is used when calculating the required amount of fuel for a flight.

For flight operation without wheel fairings the resulting performance variations is given in %.

Revision No.	Reference	Date October 20, 1993	Page 5 - 1
--------------	-----------	--------------------------	---------------

## 5.2. USE OF PERFORMANCE TABLES AND DIAGRAMS

The performance data is shown in the form of tables and diagrams to illustrate the influence of the different variables. These tables contain sufficiently detailed information to plan any flight with the necessary precision and safety on the conservative side.

Revision No.	Reference	Date	Page
		October 20, 1993	5 - 2

### 5.3. PERFORMANCE TABLE AND DIAGRAMS

#### 5.3.1. Figure 5.1: Airspeed Indicator System Calibration

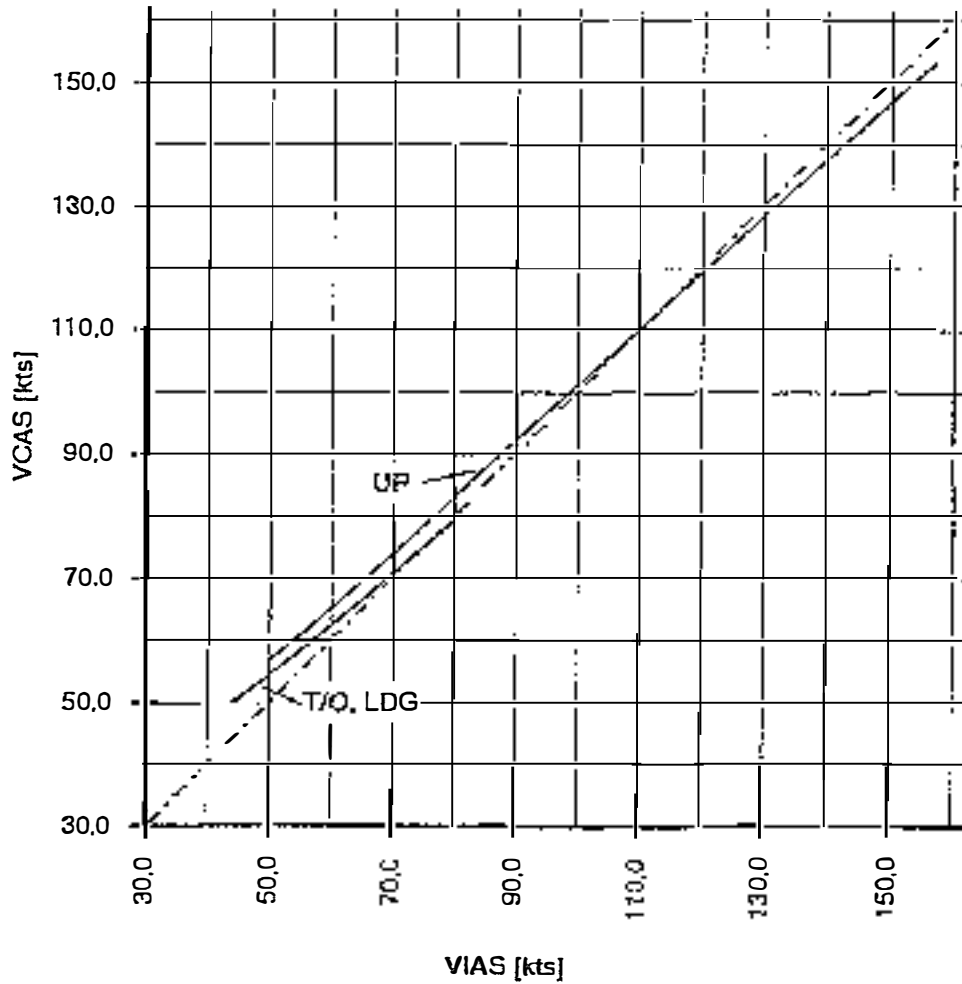

*Example:*       $v_{IAS} = 93 \text{ kts. equals } v_{CAS} = 95 \text{ kts.}$

5.3.2. Figure 5.2: Cruising Performance

Pressure Altitude		Standard Temp.		Engine power in % of max. continuous power.											
				55 %			65 %			75 %					
ft.	m	°C	°F	RPM	MP	Fuel Flow		RPM	MP	Fuel Flow		RPM	MP	Fuel Flow	
				*100	in. Hg	l/h	gal/hr	*100	in. Hg	l/h	gal/hr	*100	in. Hg	l/h	gal/hr
0	0	15	59	20	24.7	11.3	3.0	21	25.7	13.0	3.4	22	27.0	15.0	4.0
2000	600	11	52	20	24.0	12.0	3.2	21	24.7	13.3	3.5	23	25.7	15.3	4.0
4000	1200	7	45	20	23.3	13.0	3.4	22	23.3	14.0	3.7	24	24.3	16.3	4.3
6000	1800	3	38	21	22.0	14.0	3.7	23	22.7	16.3	4.3	24	23.3	19.3	5.1
8000	2400	-1	31	22	21.0	15.0	4.0	23	21.7	17.7	4.7	24	22.0	19.7	5.2
10000	3000	-5	24	23	19.7	16.0	4.2	24	20.3	18.7	4.9				
12000	3600	-8	17	24	18.0	17.3	4.6								

Pressure Altitude		Standard Temp.		85 %			95 %			105 %					
				RPM	MP	Fuel Flow		RPM	MP	Fuel Flow		RPM	MP	Fuel Flow	
ft.	m	°C	°F	*100	in. Hg	l/h	gal/hr	*100	in. Hg	l/h	gal/hr	*100	in. Hg	l/h	gal/hr
				0	0	15	59	24	27.7	18.3	4.8	24	28.3	21.7	5.7
2000	600	11	52	24	26.7	18.7	4.9	24	27.7	22.3	5.9				
4000	1200	7	45	24	25.7	21.0	5.5								

Correction of chart under non-standard conditions:

At ISA + 10° C (ISA + 18° F): The same power and fuel consumption result if manifold pressure values are increased by 0.3 inHg and pressure altitude values are decreased by 500 ft. (150 m).

At ISA - 10° C (ISA - 18° F): The same power and fuel consumption result if manifold pressure values are decreased by 0.3 inHg and pressure altitude values are increased by 500 ft. (150 m).

**NOTE**

The above chart shows the combinations of RPM and MP which result in the lowest fuel consumption at a selected power and altitude.

In general it is recommendable for a fast cruise to select 2400 RPM and an MP that is at least 0.7 inHg below the maximum possible MP at the respective cruising altitude. This measure reduces fuel consumption significantly while hardly affecting the cruising speed.

For an economical cruise, it is recommendable to select a propeller speed between 2300 and 2200 RPM and an MP that is 1-2 inHg below the maximum possible MP at the respective cruising altitude.

To keep engine wear to a minimum, engine operation below 1900 RPM is not recommended.

Revision No. 1	Reference	Date December 30, 1994	Page 5 - 4
-------------------	-----------	---------------------------	---------------

### 5.3.3. Figure 5.3: Pressure Altitude - Density Altitude

Conversion from Pressure Altitude to Density Altitude

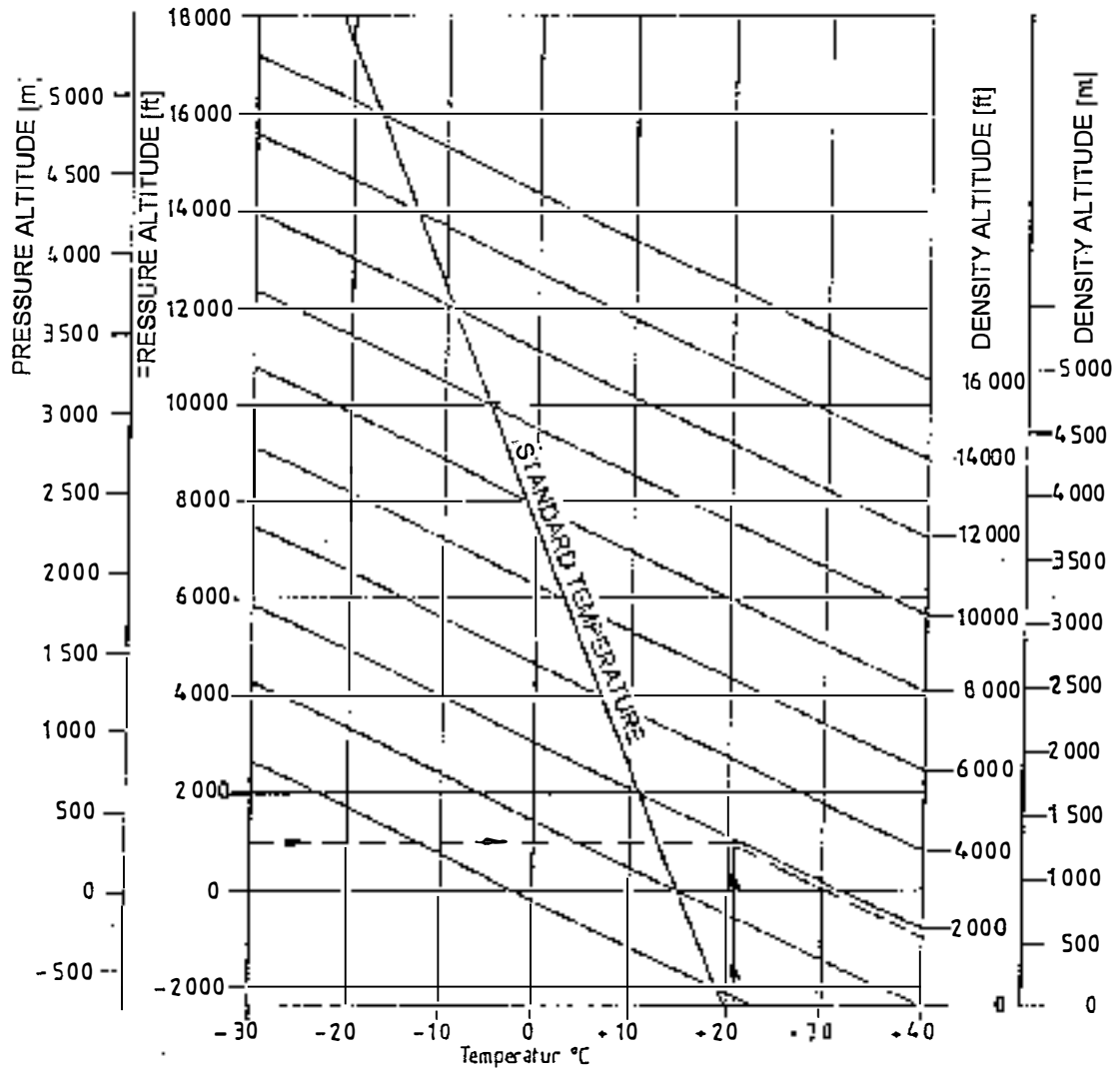

- Example:*
1. Set Altimeter to 1013.25 mbar (29.9 inHg) and read the pressure altitude (900 ft.)
  2. Determine outside air temperature (+21 °C / 70 °F)
  3. Read density altitude (1800 ft.)

*Result:* The effective altitude with respect to performance is 1800 ft.

## 5.3.4. Figure 5.4: Stall Speeds

Configuration:

Idle, most forward center of gravity, max. mass (weight)  
 (this is the most adverse configuration)

Stall speeds in km/h

Flaps	Bank Angle							
	0°		30°		45°		60°	
	IAS	CAS	IAS	CAS	IAS	CAS	IAS	CAS
UP	79	92	85	99	94	109	112	130
T/O	72	83	77	89	85	98	102	117
LDG.	70	81	75	87	83	96	99	115

Stall speeds in kts.

Flaps	Bank Angle							
	0°		30°		45°		60°	
	IAS	CAS	IAS	CAS	IAS	CAS	IAS	CAS
UP	43	50	46	53	51	59	60	70
T/O	39	45	42	48	46	53	55	63
LDG.	38	44	41	47	45	52	54	62

5.3.5. Figure 5.5: Wind Components

Demonstrated crosswind components: 15 kts. (27 km/h)

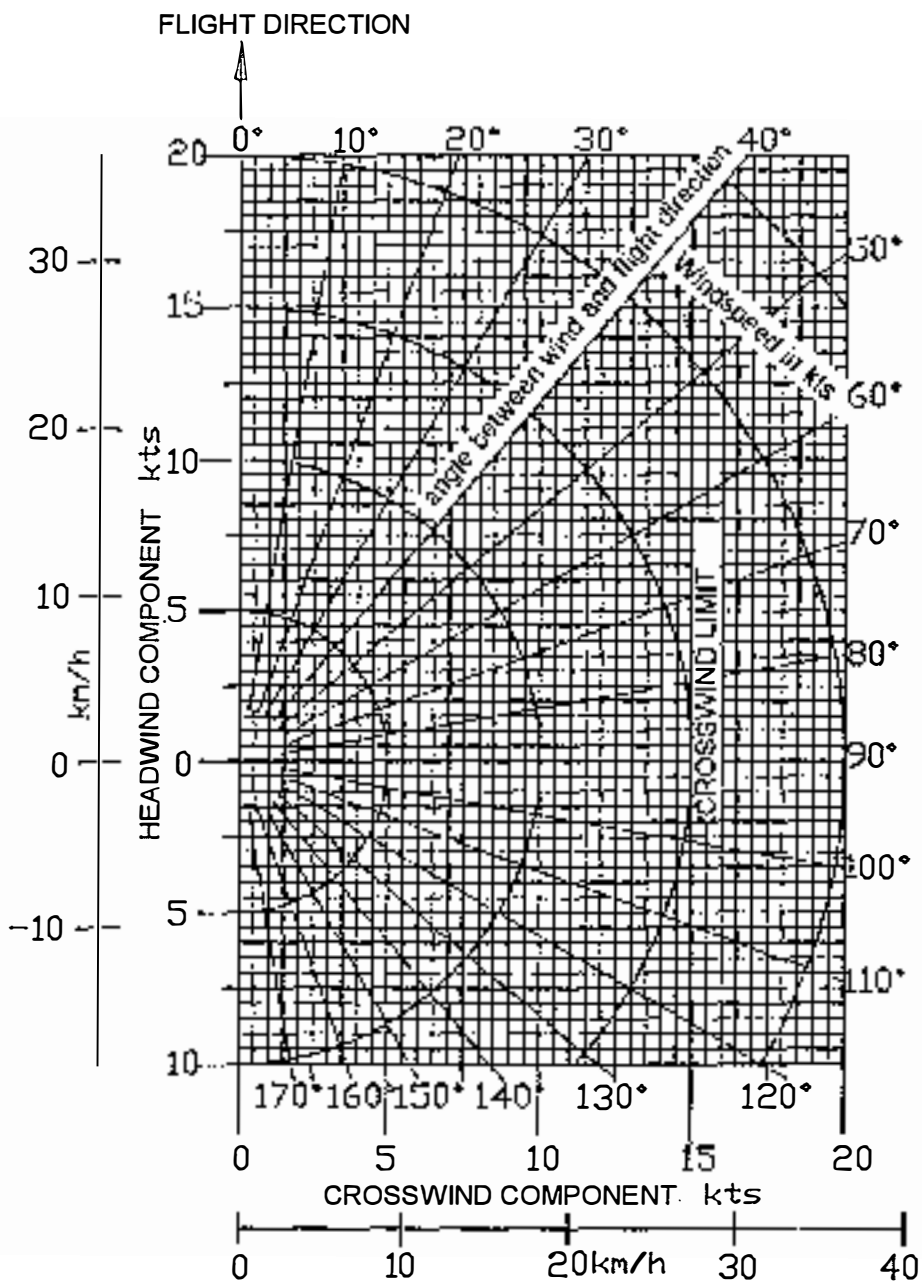

Example:

Wind speed:	11 kts (20 km/h)
Angle between wind direction and flight direction:	30 °
Headwind component:	9.5 kts (18 km/h)
Crosswind component:	5.5 kts (10 km/h)



5.3.6. Figure 5.6: Take-off Distance

Conditions:

- maximum take-off power
- take-off speed (speed for lift off and climb over the obstacle) 57 kts. / 65 mph / 105 km/h IAS
- level runway, paved
- flaps in take-off position (T/O)

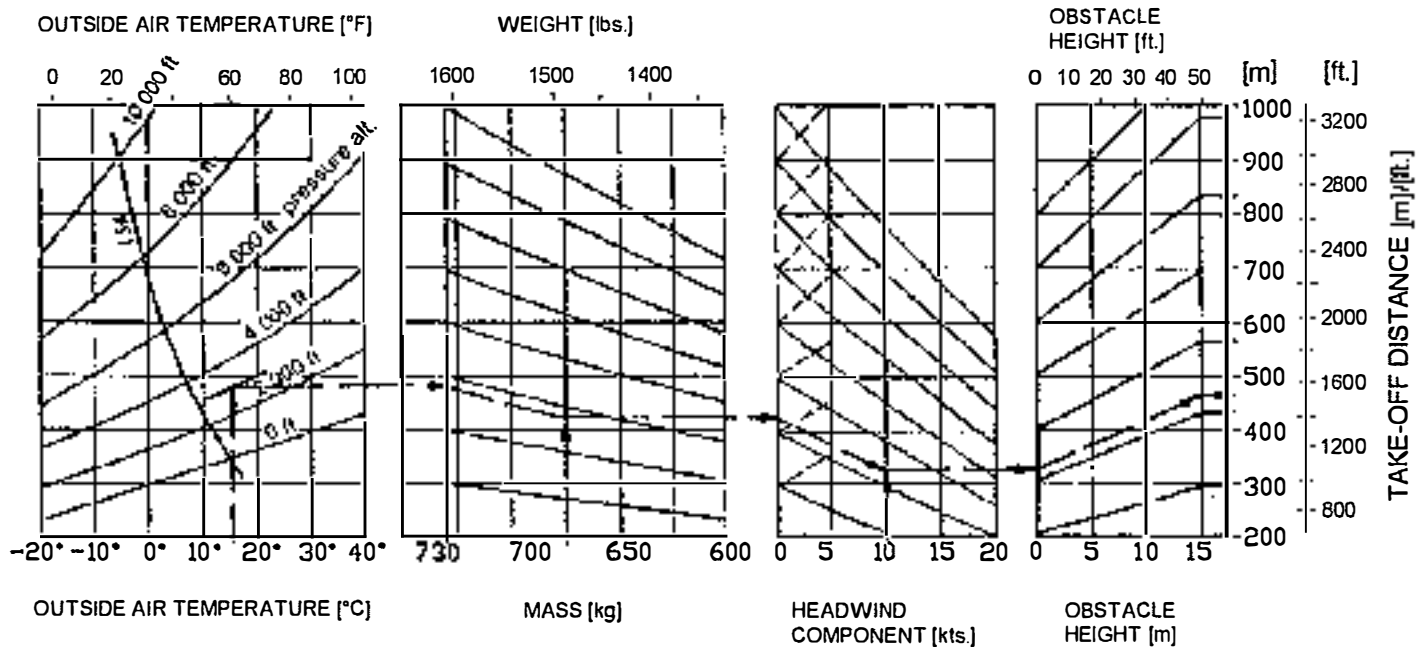

**Example:**

- Pressure altitude: 3000 ft.
- Outside temperature: 15° C (59° F)
- Mass (Weight): 675 kg (1488 lbs.)
- Wind: 10 kts.

**Result:**

- Take-off roll distance: 330 m (1080 ft.)
- Take-off distance to clear a 15 m (50 ft.) obstacle: 470 m (1540 ft.)

**NOTE**

Poor maintenance condition of the airplane, deviation from the given procedures as well as unfavorable outside conditions (high temperature, rain, unfavorable wind conditions) could increase the take-off distance considerably. For take-off from dry, short-cut grass covered runways compared to paved runways, a 25% increase in take-off roll distance must be taken into account.

On soft grass covered runways with grass deeper than 10 cm (4 in.), the take-off roll distance might be increased by as much as 40%.

The dashed lines in the above diagram (wind component) represents tailwind.

Revision No. 1	Reference	Date December 30, 1994	Page 5 - 8
-------------------	-----------	---------------------------	---------------

5.3.7. Figure 5.7 : Climb Performance / Cruising Altitudes

Max. Cruising Altitude (in standard conditions): 4000 m (13120 ft.)  
 Best Rate-of-Climb Speed with flaps in T/O position: 65 kts. / 75 mph / 120 km/h

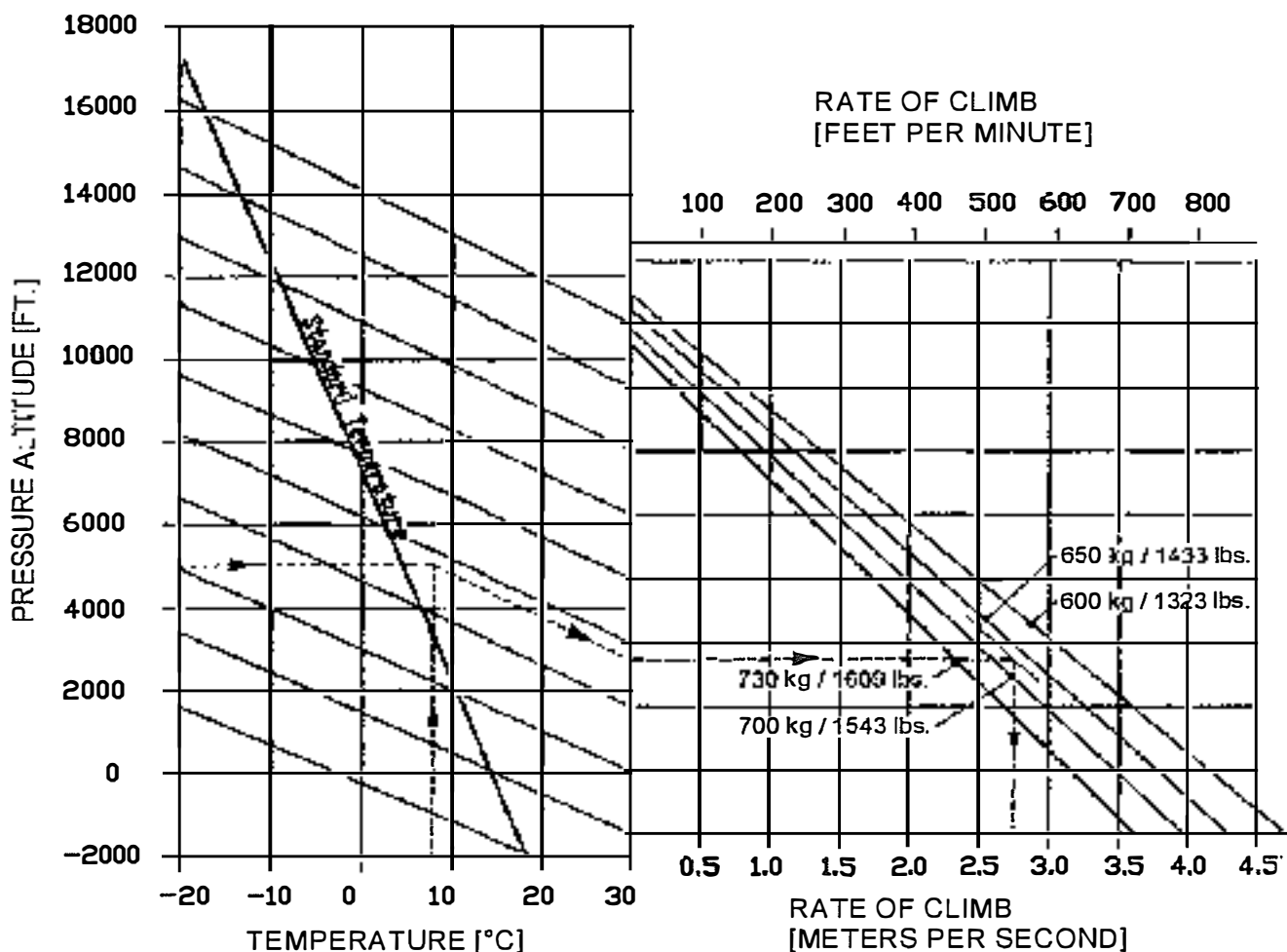

*Example:* Pressure Altitude: 5000 ft. (1520 m)  
 OAT: + 8° C (46° F)  
 Mass (Weight): 670 kg (1477 lbs.)

*Result:* Climb performance: 540 f.p.m. (2.75 m/s)

**CAUTION**

In case of operation without wheel fairings the climb performance is reduced by approximately 3%.

Revision No. 1	Reference	Date December 30, 1994	Page 5 - 9
-------------------	-----------	---------------------------	---------------

INTENTIONALLY LEFT BLANK

Revision No.	Reference	Date October 20, 1993	Page 5 - 10
--------------	-----------	--------------------------	----------------

5.3.9. Figure 5.9: Cruise Speed (True Airspeed)

Diagram for true airspeed (TAS) calculation at selected power level.

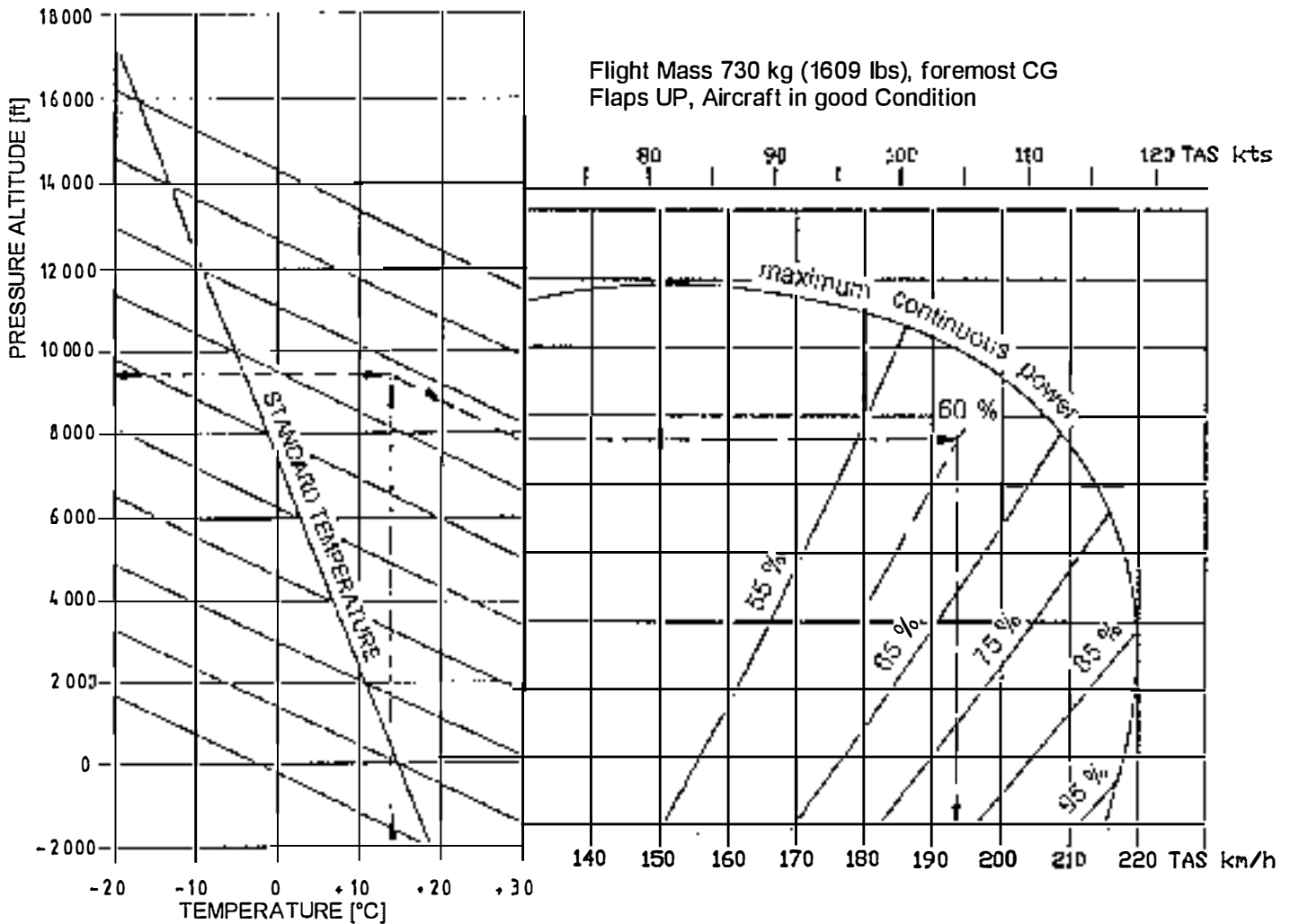

**Example:** Pressure altitude: 9500 ft  
 Temperature: + 14 °C (57 °F)  
 power setting: 60 %

**Result:** True airspeed (TAS): 104.2 kts (193 km/h)

**CAUTION**

In case of operation without wheel fairings the maximum cruise speed is reduced by approximately 5%.

Revision No.	Reference	Date	Page
		October 20, 1993	5 - 11

5.3.10. Figure 5.10: Maximum Flight Duration

Diagram for calculation of the maximum flight duration depending on fuel availability.

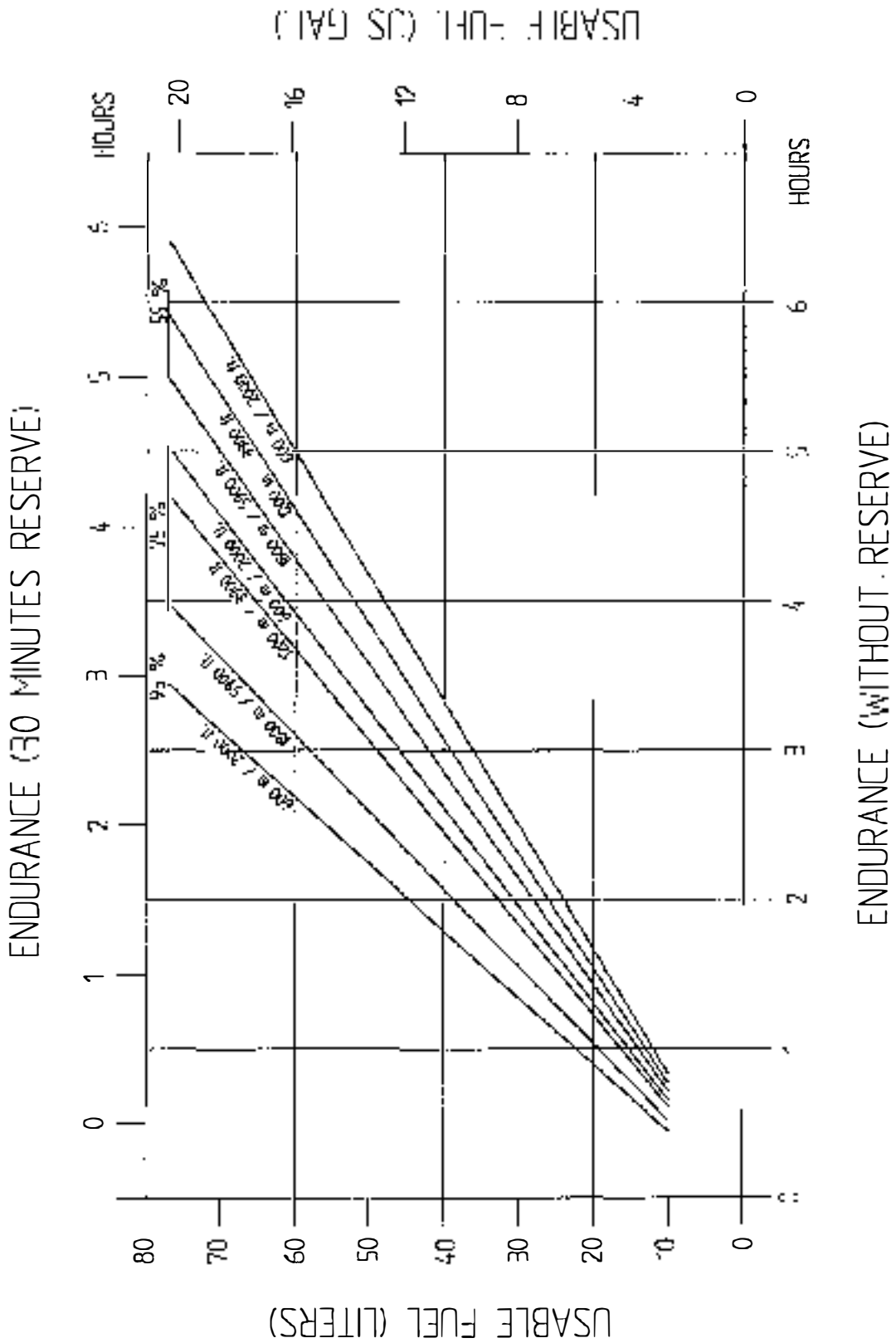

5.3.11. Figure 5.11: Climb performance during balked landing

Conditions: Speed = 58 kts / 67 mph / 108 km/h  
 Flaps in Landing Position (LDG)  
 Mass (Weight) 730 kg (1609 lbs)  
 foremost center of gravity  
 max take-off power

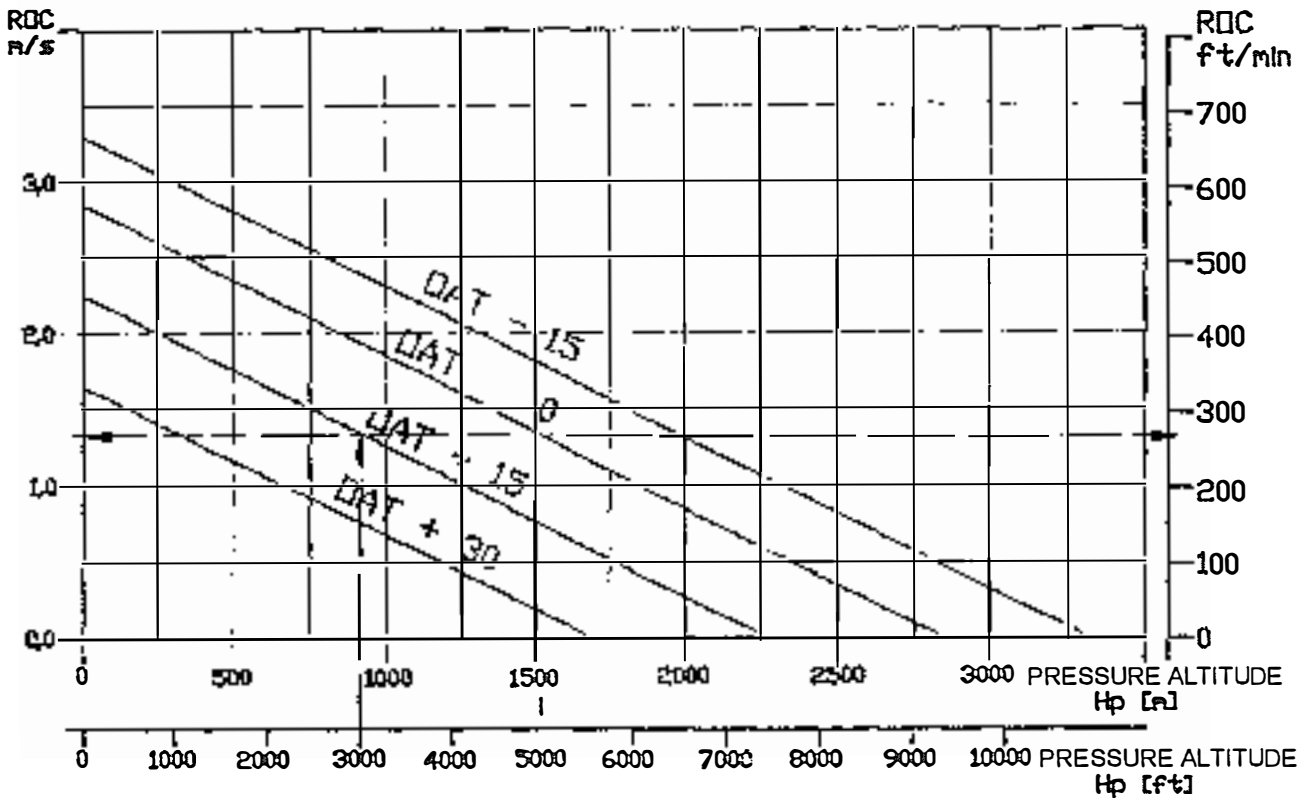

*Example:* Pressure altitude: 3000 ft  
 Outside temperature: +15 °C (59 °F)

*Result:* Climb performance during balked landing: 270 ft/min. (1.3 m/s)

**CAUTION**

In case of operation without wheel fairings the climb performance is reduced by approximately 3%.

### 5.3.12. Landing Distance

- Conditions:
- Idle
  - Maximum T/O Mass (Weight)
  - max RPM
  - Approach speed 59 kts (68 mph / 110 km/h)
  - level runway, paved
  - Flaps in landing position
  - Standard setting, MSL

Landing distance over a 15 m (50ft) obstacle: approx. 454 m (1490 ft)

Landing roll distance: approx. 228 m (748 ft)

For each 750 m (2500 ft) additional height above MSL add 10% to the landing distance.

### NOTE

Poor maintenance condition of the airplane, deviation from the given procedures as well as unfavorable outside conditions (high temperature, rain, unfavorable wind conditions) could increase the landing distance considerably.

### 5.4. NOISE DATA

- |    |   |            |
|----|---|------------|
| a) | Noise limit according to FAR 36, Appendix G:        | 74.8 dB(A) |
|    | Noise value measured:                               | 65.2 dB(A) |
| b) | Noise limit according to ICAO Annex 16, Chapter 10: | 71.9 dB(A) |
|    | Noise value measured:                               | 63.6 dB(A) |

## CHAPTER 6

### MASS (WEIGHT) AND BALANCE / EQUIPMENT LIST

<b>6.1. INTRODUCTION</b>	<b>6-1</b>
<b>6.2. AIRPLANE WEIGHING</b>	<b>6-2</b>
- Figure 6.1 Weighing Report	<b>6-4</b>
<b>6.3. MASS (WEIGHT) AND BALANCE REPORT</b>	<b>6-5</b>
- Figure 6.2 Mass(Weight) & Balance Report	<b>6-6</b>
<b>6.4. FLIGHT-MASS(WEIGHT) AND CENTER OF GRAVITY</b>	<b>6-7</b>
- Figure 6.3 Mass(Weight) & Balance Diagram	<b>6-8</b>
- Figure 6.4 Permissible Center of Gravity Range and permissible Flight Mass(Weight)-Moment	<b>6-9</b>
- Figure 6.5 Calculation of the Load Limits	<b>6-10</b>
<b>6.5. EQUIPMENT LIST</b>	<b>6-11</b>

#### 6.1. INTRODUCTION

To obtain the flight performance, flight characteristics and safe flight operation described in this Flight Manual, the airplane must be operated well within the permissible load and balancing envelope presented in this manual. It is the pilot's responsibility to adhere the load and balance limitations as well as to account for the change of the CG position due to the consumption of fuel during flight.

The permissible balance envelope during flight is described in Chapter 2.

The procedures for weighing the airplane as well as the method of calculating the CG position are given in this Chapter.

Revision No.	Reference	Date October 20, 1993	Page 6 - 1
--------------	-----------	--------------------------	---------------



Prior to delivery of an airplane, the empty mass(weight) and the CG position are determined. Empty mass (weight) and the center of gravity are recorded in a Weighing Report as illustrated in Figure 6.1 and in the Mass(Weight) & Balance Report (Figure 6.2).

### NOTE

After equipment changes the new empty mass (weight) and the corresponding CG must be determined by calculation or weighing.

After repair or painting work the new empty mass (weight) and the corresponding CG must be determined by weighing.

Empty mass (weight) and corresponding CG position and moment must be entered in the Mass (Weight) & Balance Report by an authorized person.

The following pages are sample forms which can be used for airplane weighing, calculation of the CG position, and for the determination of the useful load.

## 6.2. AIRPLANE WEIGHING

Pre-weighing Conditions:

- Equipment must be in accordance with the airplane equipment list.
- Inclusive brake fluid, lubricant (3 liters / 3.17 US qts.), coolant (2,5 liters / 2.64 US qts.) and unusable fuel (2 liters / 0.53 US gal.).

To determine the empty mass (weight) and the CG position, the airplane is to be positioned in the above mentioned pre-weighing condition, with the nose gear and the main gears on a scale each. It should be ensured that the longitudinal axis of the airplane is in a horizontal position as illustrated on the Weighing Report (see Figure 6.1).

With the airplane correctly positioned, a plumb line is dropped on the leading edge of the wing from the root rib to the ground to determine the reference datum (RD). From this plane, the distances  $x_1$ ,  $x_{2li}$  (left), and  $x_{2re}$  (right) are measured to the wheel axes and recorded in the Weighing Report. The empty mass (weight) is calculated from the individual values of  $G_1$ ,  $G_{2li}$  (left), and  $G_{2re}$  (right).

The formula:

$$x_L = \frac{1}{G_L} * (G_{2li} * x_{2li} + G_{2re} * x_{2re} - G_1 * x_1)$$

yields the empty mass (weight) CG position aft of RD.

Revision No.	Reference	Date	Page
1		December 30, 1994	6 - 2

The most important lever arms, indicated in meters (inches) aft of RD (leading edge of wing at the root rib):

- Pilot, Copilot: : 0.143 m (5.63 in)
- 79 liters (20.9 US gal.) Tank : 0.824 m (32.44 in)
- Baggage (max 20 kg (44 lbs)) : 0.824 m (32.44 in)

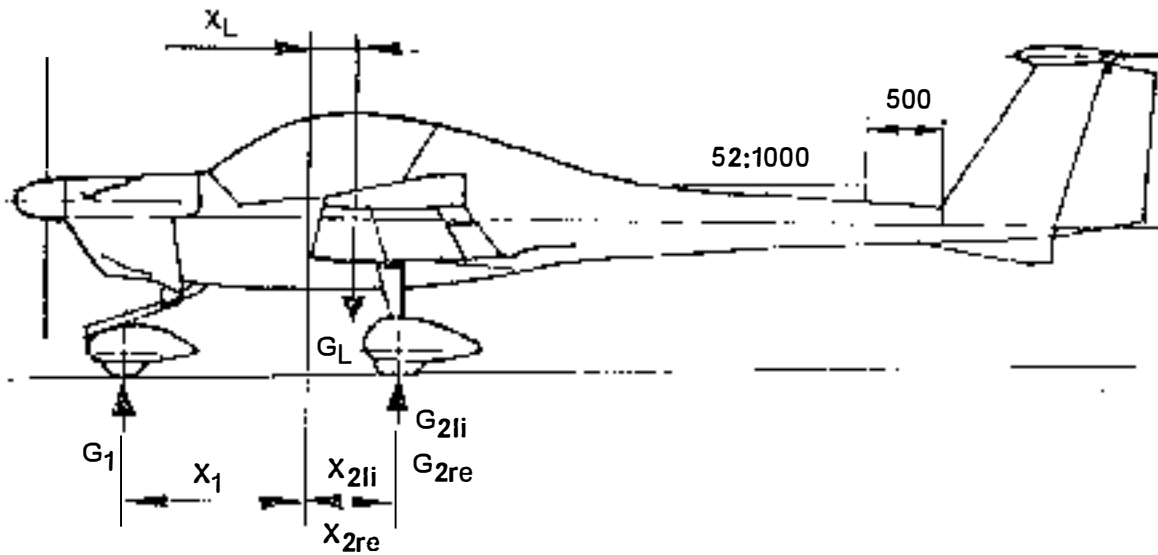

Weighing Schematic

Revision No.	Reference	Date	Page
		October 20, 1993	6 - 3

Figure 6.1: Weighing Report

Model: DV 20 S/N: \_\_\_\_\_ Registration: \_\_\_\_\_

Data in accordance with TCDS and Flight Manual Reason for Weighing: \_\_\_\_\_

Reference Datum : Leading edge of wing at root rib

Horizontal reference line: Wedge 52.1000. 500 mm (19.69 in.) forward of rudder fin

Weighing and empty mass (weight) CG

Equipment list - dated: \_\_\_\_\_

Weighing Conditions: Including Brake Fluid,  
Lubricant, Coolant and  
Unusable Fuel (1.5 kg /3.31 lbs.)

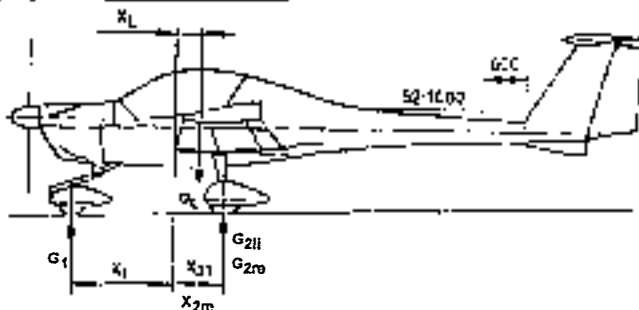

Support	Gross [kg] ([lbs])	Tare [kg] ([lbs])	Net Mass [kg] ([lbs])	Lever Arm [m] ([in])
Front G <sub>1</sub>				x <sub>1</sub> =
Rear G <sub>2l</sub>				x <sub>2l</sub> =
Rear G <sub>2r</sub>				x <sub>2r</sub> =
Empty Mass (Weight) G <sub>L</sub> =				kg (lbs.)

CG Position for Empty Mass (Weight):

Empty Mass (Weight) Moment:  $M_L = G_L * x_L =$  \_\_\_\_\_ \* \_\_\_\_\_ = \_\_\_\_\_ kg\*m (in\*lbs)

Maximum Permissible Useful Load:

Maximum Mass (Weight) [kg] ([lbs])	_____
Empty Mass (Weight) [kg] ([lbs])	_____
Max useful Load [kg] ([lbs])	_____

Data to be entered into the Flight Manual: see page 6 - 6

Empty Mass (Weight) [kg] ([lbs])	Empty Mass Moment [kg*m] ([in*lbs])
_____	_____

Place / Date	A.M.E.'s Stamp	A.M.E.'s Signature

Revision No. 1	Reference	Date December 30, 1994	Page 6 - 4
-------------------	-----------	---------------------------	---------------

### 6.3. MASS (WEIGHT) AND BALANCE REPORT

The empty mass (weight) and empty mass (weight) CG position data determined prior to delivery of the airplane is the first entry in the Mass (Weight) and Balance Report. Each change of the installed equipment as well as each repair affecting the empty mass (weight) or empty mass (weight) CG position must be entered in the Mass (Weight) and Balance Report.

For calculations of the flight mass (weight) and the corresponding center of gravity, or the flight mass (weight) moment, the latest empty mass (weight) and the corresponding center of gravity or the empty mass (weight) moment must be used.

Revision No.	Reference	Date	Page
1		December 30, 1994	6 - 5



## 6.4. FLIGHT MASS(WEIGHT) AND CENTER OF GRAVITY

The following data enables the pilot to operate the DV 20 within the required mass (weight) and center of gravity limitations.

The following diagrams:

Figure 6.3 Mass (Weight) & Balance Diagram

Figure 6.4 Permissible Center of Gravity Range  
and permissible Flight Mass (Weight) Moment

Figure 6.5 Calculation of Loading Condition

are to be used for calculations of the flight mass (weight) and the center of gravity as follows:

1. The empty mass (weight) and the empty mass (weight) moment of the airplane should be taken from the Mass (Weight) & Balance Report and entered into the form "Calculation of Loading Condition" (Figure 6.5) in the columns identified with "Your DV 20".
2. Using the Mass (Weight) & Balance Diagram (see Figure 6.3) determine the moment for each item to be loaded, and enter it in the respective column in Figure 6.5.
3. Add the masses (weights) and the moments of each column (items 4 and 6 in Figure 6.5) and enter the sum in Figure 6.4 "Permissible CG Range and Permissible Flight Mass (Weight) Moment" to check if the values are within the permissible limits of the loading range.

Revision No.	Reference	Date	Page
1		December 30, 1994	6 - 7

Figure 6.3: Mass(Weight) & Balance Diagram

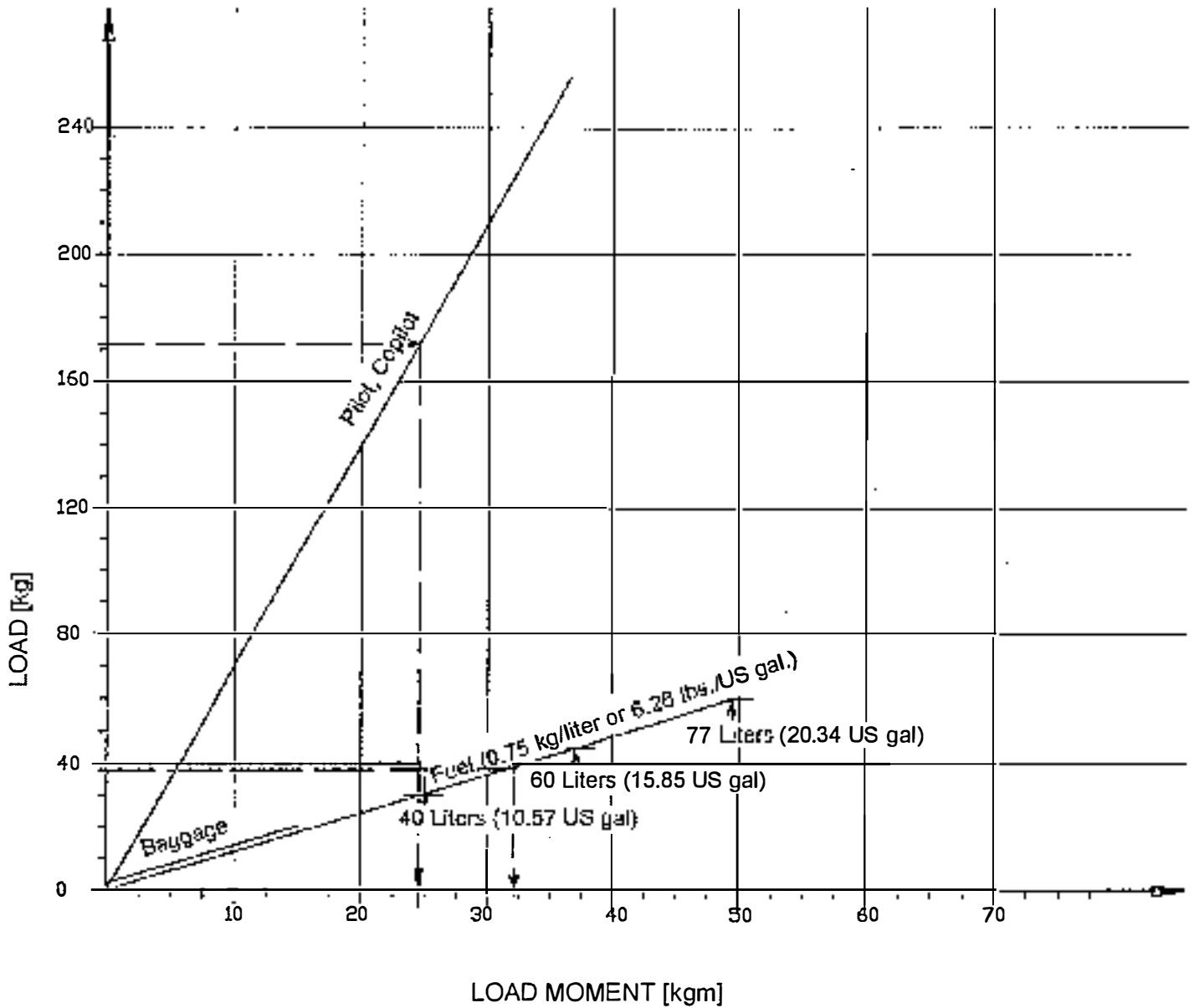

*Example:* Pilot and Passenger: 172 kg (380 lbs.)  
 Fuel (0.75 kg/liter): 38 kg  
 (6.28 lbs./US gal. : 84 lbs.)

*Result:* Moment of Pilot and Passenger: 24.6 kgm (2112 in.lbs.)  
 Moment of Fuel: 32 kgm (2747 in.lbs.)

Figure 6.4: Permissible Center of Gravity Range and permissible Flight-Mass (Weight)-Moment

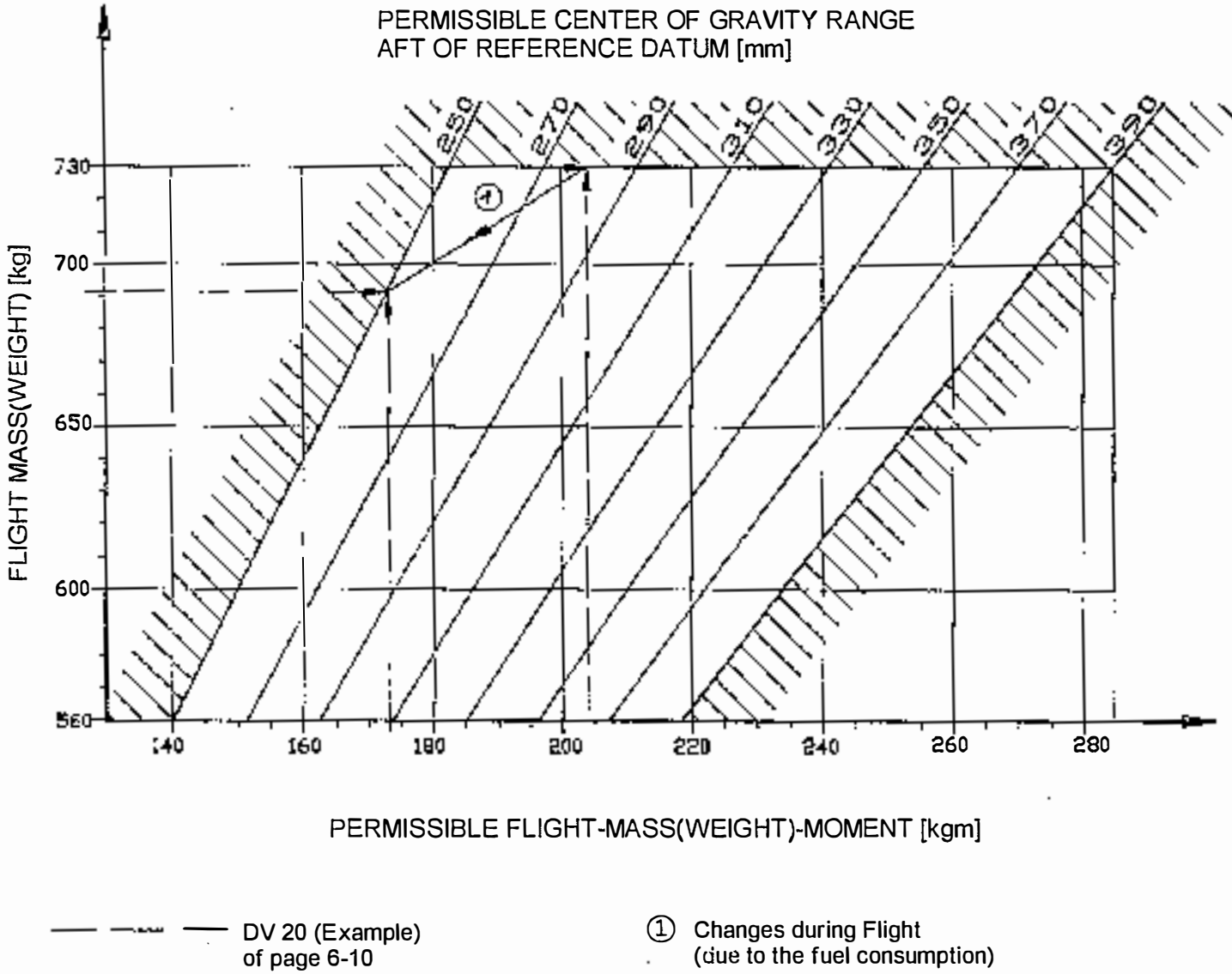



Figure 6.5: Calculation of the Load Limits

Calculation of the Load Limits	DV 20 (Example)		Your DV 20	
	Mass [kg]	Moment [kgm]	Mass [kg]	Moment [kgm]
	(Weight [lbs])	(In lbs.)	(Weight [lbs])	(In lbs.)
1. Empty Mass(Weight), to be taken from the Mass (Weight) & Balance Report.	520 (1147)	148.404 (12888)		
2. Pilot and Passenger: Lever Arm: 0.143 m (5.63 in)	172 (380)	24.596 (2112)		
3. Baggage: Lever Arm: 0.824 m (32.44 in)	-- (--)	-- (--)		
4. Total Mass (Weight) and Total Moment with empty fuel tank (add lines 1-3)	<b>692</b> <b>(1526)</b>	<b>173.000</b> <b>(15000)</b>		
5. Usable Fuel Load 0.75 kg/liter (6.26 lbs./US gal.) Lever Arm: 0.824 m (32.44 in)	38 (84)	31.996 (2747)		
6. Total Mass (Weight) and Total Moment, taking fuel into account (add 4. and 5.)	<b>730</b> <b>(1609)</b>	<b>204.996</b> <b>(17747)</b>		
7. Find the values for the total mass (weight) (692 kg and 730 kg) and the total moment (173 kgm and 205 kgm) in the center of gravity diagram (Fig. 6.4). Since they are within the limitation range, the loading is permissible.				

## 6.5. EQUIPMENT LIST

The following table lists the equipment of the airplane. The equipment installed in your airplane is marked as installed in the respective column (Inst.).

The equipment list comprises the following data:

- The item No. containing an alpha character for the equipment group and a sequential number.

Abbreviations:

A	Avionics
E	Electric
I	Instruments
T	Powerplant
Z	Airframe, Landing Gear

- Mass(Weight) and lever arm of the equipment items are shown in the columns "Mass" and "Arm".

The data corresponds to one equipment item if not specially marked. (e.g. for the ACL-Power-Supply: each power-supply has a mass(weight) of 0.43 kg (0.95 lbs.)).

### NOTE

Additional installation of equipment must be carried out in compliance with the specifications in the Maintenance Manual. The columns "Mass" and "Arm" show the mass(weight) and the CG position of the equipment with respect to the reference datum. A positive value shows the distance aft of the reference datum, a negative value shows the distance forward of the reference datum.

Revision No.	Reference	Date October 20, 1993	Page 6 - 11
--------------	-----------	--------------------------	----------------

Equipment List		Airplane Serial No.:		Registr.:	
				Date:	
Seq. No.:	Part Description, Manufacturer, Type	Serial No.:	Inst.	Mass [kg] (lbs)	Arm [m] (in)
A 1	COMM Transceiver Becker, AR3201(.)			0.90 (1.98)	-0.420 (-16.54)
A 2	COMM Transceiver Bendix/King, KY 97A			1.27 (2.8)	-0.420 (-16.54)
A 3	COMM Antenna Dittel, F100057			0.21 (0.46)	+4.350 (+171.26)
A 4	NAV/COMM Transceiver Bendix/King, KX125			1.89 (4.17)	-0.420 (-16.54)
A 5	NAV/COMM Transceiver Bendix/King KX155			2.24 (4.94)	-0.420 (-16.54)
A 6	NAV Receiver Becker, NR3301-(2)			0.85 (1.87)	-0.420 (-16.54)
A 7	NAV Indicator Becker, IN3360			0.45 (0.99)	-0.390 (-15.35)
A 8	NAV Indicator Becker, IN3300			0.80 (1.76)	-0.390 (-15.35)
A 9	NAV Indicator Bendix/King KI203			0.68 (1.50)	-0.390 (-15.35)
A 10	NAV Indicator Bendix/King KI204			0.68 (1.50)	-0.390 (-15.35)
A 11	NAV Indicator Bendix/King KI207			0.59 (1.30)	-0.390 (-15.35)
A 12	NAV Indicator Bendix/King KI208			0.46 (1.10)	-0.390 (-15.35)
A 13	NAV Antenna Becker, 1A050			0.17 (0.37)	+4.760 (+187.40)
A 14	Encoding Altimeter United, 5035P2-P27			0.73 (1.61)	-0.420 (-16.54)



Equipment List		Airplane Serial No.:		Registr.:	
				Date:	
Seq. No.:	Part Description, Manufacturer, Type	Serial No.:	Inst.	Mass (kg) (lbs)	Arm (m) (in)
E 1	Battery Banner, 53030, 12V/30Ah			7.90 (17.42)	-0.748 (-29.45)
E 2	Low Voltage Warning Light RCA 33-2013			0.25 (0.55)	-0.590 (-23.23)
E 3	ACL with pos. light Whelen, A 600, left and right			0.22 (0.49)	+1.000 (+39.37)
E 4	ACL Power Supply Whelen, A 490, T, DF-14			0.43 (0.95)	+0.570 (+22.44)
E 5	Position Light Whelen, A 675, left and right			0.15 (0.33)	+1.000 (+39.37)
E 6	Landing Light HOAC 16035			0.23 (0.51)	-1.480 (-58.27)
E 7	Cockpit Speaker HOAC 16003			0.37 (0.82)	+0.580 (+22.83)
E 8	Boom Microphone Becker, 1 PM 004			0.34 (0.75)	+0.530 (+20.87)
E 9	Boom Microphone Comunica Bommic			0.20 (0.44)	+0.530 (+20.87)
E 10	Hand Microphone Telex, TRA 100			0.17 (0.37)	-0.300 (-11.81)
E 11	Headset, dynamic mic HOAC 16118, left and right			0.42 (0.93)	+0.143 (+5.63)
E 12	Headset, standard mic HOAC 16107, left and right			0.44 (0.97)	+0.143 (+5.63)
E 13	Wing Flap Motor HOAC 15770			1.50 (3.31)	+0.120 (+4.72)
E 14	Flap Control Unit HOAC 15771			0.35 (0.77)	-0.390 (-15.35)
E 15	Intercom, voice activated nat AA 80-001			0.28 (0.62)	-0.390 (-15.35)
E 16	Intercom, voice activated PS Engineering PM 501			0.21 (0.46)	-0.390 (-15.35)

Equipment List		Airplane Serial No.:		Registr.:	
				Date:	
Seq. No.:	Part Description, Manufacturer, Type	Serial No.:	Inst.	Mass [kg] (lbs)	Arm [m] (in)
11	Ammeter, dampened HOAC 16154			0.08 (0.18)	-0.390 (-15.35)
12	Manifold Pressure Indicator UMA Inc. 7-100-10			0.13 (0.29)	-0.390 (-15.35)
13	Oil Pressure Indicator HOAC 16150			0.14 (0.31)	-0.390 (-15.35)
14	Oil Temperature Indicator HOAC 16161			0.14 (0.31)	-0.390 (-15.35)
15	Fuel Quantity Indicator HOAC 16159			0.09 (0.20)	-0.390 (-15.35)
16	Cylinder Head Temp. Indicator HOAC 16160			0.14 (0.31)	-0.390 (-15.35)
17	RPM Indicator HOAC 16301			0.38 (0.84)	-0.390 (-15.35)
18	Altimeter United, 5934 AM-3			0.39 (0.86)	-0.390 (-15.35)
18A	Altimeter United, 5934 PA-3			0.39 (0.86)	-0.390 (-15.35)
19	Airspeed Indicator United, 8000			0.30 (0.66)	-0.390 (-15.35)
110	Emergency Compass Airpath, C2300			0.29 (0.64)	-0.005 (-0.20)
111	Vertical Speed Indicator United, 7000			0.35 (0.77)	-0.390 (-15.35)
112	Turn and Slip Indicator 2" United, 9500			0.56 (1.23)	-0.390 (-15.35)
113	Turn and Slip Indicator 2" United, 9501			0.56 (1.23)	-0.390 (-15.35)
114	Turn coordinator United, 9000			0.77 (1.70)	-0.390 (-15.35)

Equipment List		Airplane Serial No.:		Registr.:	
		Serial No.:	Inst.	Date:	
Seq. No.:	Part Description, Manufacturer, Type	Serial No.:	Inst.	Mass [kg] (lbs)	Arm [m] (in)
I 15	Turn indicator Elec. Gyro. C.1394T100-7Z			0.47 (1.04)	-0.390 (-15.35)
I 16	Turn and Slip Indic. Elec. Gyro. C. 1294T100-7ATZ			0.47 (1.04)	-0.390 (-15.35)
I 17	Turn and Bank Indic. AIM, TS400-1A			0.77 (1.7)	-0.390 (-15.35)
I 18	Turn and Bank Indic. R.C.Allen. RCA82-11			0.57 (1.25)	-0.390 (-15.35)
I 19	Directional Gyro R.C.Allen, RCA15AK-2			1.11 (2.45)	-0.390 (-15.35)
I 20	Directional Gyro AIM, 205-1A			1.36 (3.0)	-0.390 (-15.35)
I 21	Attitude Gyro R.C.Allen, RCA26AK-4			1.10 (2.43)	-0.390 (-15.35)
I 22	Attitude Gyro AIM, 305-2A			1.13 (2.5)	-0.390 (-15.35)
I 23	Emergency Locator Trans. Pointer, 3000			0.96 (2.12)	+1.400 (+5.12)
I 24	Emergency Locator Antenna Pointer, 3007			0.05 (0.11)	+1.500 (+49.06)
I 25	Accelerometer Bendix, BM-470			0.30 (0.66)	-0.390 (-15.35)
I 26	Running Time Meter Hobbs 85000			0.08 (0.18)	-0.390 (-15.35)
I 27	Outside Air Temperature Indicator HOAC 16158			0.05 (0.11)	-0.390 (-15.35)





Equipment List		Airplane Serial No.:		Registr.:	
Seq. No.:	Part Description, Manufacturer, Type	Serial No.:	Inst.	Mass [kg] (lbs)	Arm [m] (in)
Z 1	Pitot Tube HOAC 16450			0.22 (0.49)	+0.400 (+5.75)
Z 4	Wheel Fairing, Main Gear left: HOAC 13532 right: HOAC 13530			1.20 (2.65)	+0.700 (+27.56)
Z 5	Wheel Cover, Nose Gear HOAC 13534			1.20 (2.65)	-1.139 (-44.84)
Z 6	Baggage Harness HOAC 12881			0.30 (0.66)	+0.700 (+27.56)
Z 7	Seat Belt left: autoflug 12B-47 right: autoflug 12D-47			1.20 (2.65)	+0.250 (+9.84)
Z 8	Shoulder Harness left: autoflug 12B-26 right: autoflug 12B-26			0.80 (1.76)	+0.400 (+15.75)
Z 9	Seat Cushion, standard left: HOAC 18102 right: HOAC 18101			1.70 (3.75)	+0.143 (+5.63)
Z 10	Seat Cushion, leather left: HOAC 18170 right: HOAC 18160			2.70 (5.95)	+0.143 (+5.63)
Z 11	First Aid Kit HOAC 18027			0.90 (1.98)	+0.950 (+37.40)
Z 12	Fire Extinguisher HOAC 18025			2.20 (4.85)	+0.660 (+25.98)
Z 13	Fire Extinguisher AMEREX A 620			1.02 (2.25)	+0.660 (+25.98)
Z 14	Sun Protection Painting HOAC			0.20 (0.44)	+0.500 (+19.68)
Z 15	Wing Folding Mechanism HOAC			new weighing required	
Z 16	Neck-rests, standard HOAC 18130			0.37 (0.82)	+0.580 (+22.83)
Z 17	Neck-rests, leather HOAC 18119			0.405 (0.89)	+0.580 (+22.83)
Z 18	GPS 95 Preparation HOAC			new weighing required	
Revision No. 1	Reference	Date December 30, 1994	Page 6 - 18		

## CHAPTER 7

# DESCRIPTION OF THE AIRPLANE AND ITS SYSTEMS

7.1. INTRODUCTION	7-1
7.2. AIRFRAME	7-2
7.3. FLIGHT CONTROLS	7-2
7.4. INSTRUMENT PANEL	7-5
7.5. LANDING GEAR SYSTEM	7-6
7.6. SEATS AND SAFETY BELTS	7-7
7.7. BAGGAGE COMPARTMENT	7-7
7.8. CANOPY	7-8
7.9. POWERPLANT	7-9
7.10. FUEL SYSTEM	7-11
7.11. ELECTRICAL SYSTEM	7-14
7.12. PITOT AND STATIC PRESSURE SYSTEMS	7-16
7.13. STALL WARNING	7-16
7.14. AVIONICS	7-16

### 7.1. INTRODUCTION

This Chapter provides description and operation of the airplane and its systems. Refer to Chapter 9, Supplements, for details of optional systems and equipment.

Revision No.	Reference	Date	Page
		October 20, 1993	7 - 1

## 7.2. AIRFRAME

### Fuselage

The GFRP-fuselage is of semi-monocoque construction. The fire protection cover on the fire wall is made from a special fire retarding fleece, that is covered by a stainless steel plate on the engine side. The main bulkhead is of CFRP/GFRP construction.

The GFRP-instrument panel permits the installation of instruments up to a maximum mass (weight) of 17 kg (37.5 lbs)

### Wings

The GFRP-wings are of semi-monocoque sandwich construction, and contain a CFRP-spar. The ailerons and flaps are made from CFRP and are attached to the wings using aluminum hinges.

The wing-fuselage connection is made with three bolts each.

The so-called A- and B- bolts are fixed to the fuselage's root rib. The A-bolt is placed in front of the spar tunnel, the B-bolt lies near the trailing edge.

The two main bolts are placed in the middle of the spar tunnel (main bulkhead). They are accessible between the backrests and can be inserted from the front side. A spring loaded hook locks both bolt handles, thereby securing them.

### Empennage

The rudder and elevator units are of semi-monocoque sandwich construction. The vertical stabilizer contains a folded-top antenna for the radio equipment, the horizontal stabilizer contains a antenna for the NAV equipment (VOR).

## 7.3. FLIGHT CONTROLS

The ailerons and elevator are actuated via push rods, and the rudder is controlled using control cables. The flaps have three positions (cruise [UP], take-off [T/O], and landing [LDG]) and are electrically operated. The switch is located on the instrument panel. In addition the flap control circuit is provided with a manually triggerable circuit breaker.

Elevator forces may be balanced using a trim tab on the elevator.

Revision No.	Reference	Date October 20, 1993	Page 7 - 2
--------------	-----------	--------------------------	---------------

### Trim System

Green knob on center console behind engine control unit. The spring loaded trim knob can be unlocked and moved to the desired position by pulling it upwards. Releasing the knob will cause it to lock in the desired position.

knob forward = nose down

### Flaps

The flaps are driven by an electric motor. The flaps are controlled by a three position flap operating switch on the instrument panel. The three positions of the switch correspond to the position of the flaps, where the top position of the switch is used during cruise flight. When the switch is moved to a different position, the flaps move automatically until the selected position is reached (follow up system). The cruise (fully retracted) and landing (fully extended) positions are additionally equipped with a limit switch to prevent overtraveling.

The control of the position is done by a notch/switch device. Due to the special circuits, the system is redundant.

The electric flap actuator is protected by an automatic circuit breaker (3.5 A) located in the circuit breaker panel at the top of the instrument panel and can also be triggered manually.

### Flap Position Indicator

The current flap position is indicated by three control lights beside the flap operating switch.

When the upper light illuminates (green), the flaps are in cruise position (UP). When the center light illuminates (yellow) the flaps are in take-off (T/O) position. When the lower light (yellow) illuminates,

Revision No.	Reference	Date October 20, 1993	Page 7 - 3
--------------	-----------	--------------------------	---------------

the flaps are in landing (LDG) position. When two lights are illuminated at the same time, the flaps are between these two positions. This is the case when the flaps are in motion.

### Pedal Adjustment

#### **NOTE**

The pedals may only be adjusted on the ground.

The pedals are unlocked by pulling the black T-grip located in the front of the control stick.

#### Forward Adjustment:

Push both pedals forward with your feet while pulling the black T-grip.

#### Backward adjustment:

Pull pedals backward to desired position by pulling on black T-grip. After the T-grip is released, push the pedals forward with your feet until they lock in place.

Revision No.	Reference	Date October 20, 1993	Page 7 - 4
--------------	-----------	--------------------------	---------------

7.4. INSTRUMENT PANEL

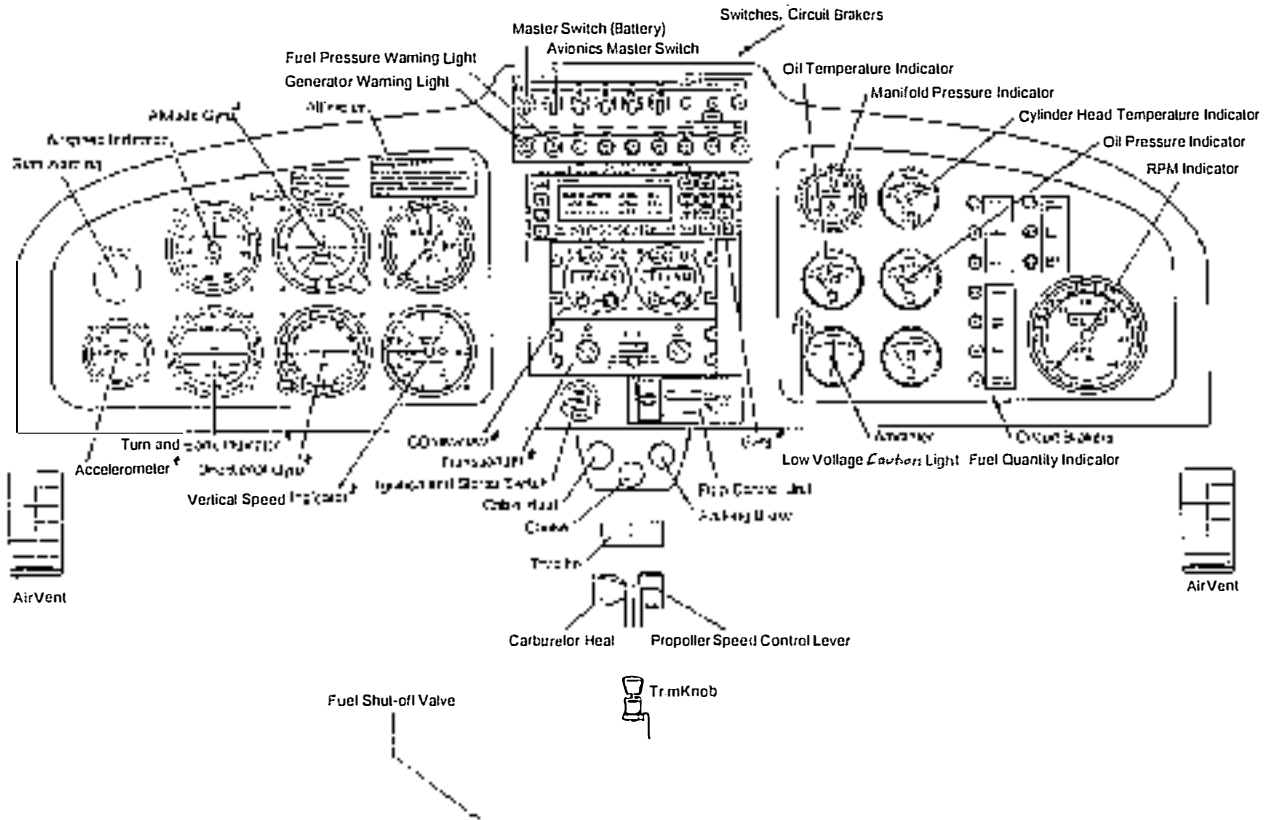

(instruments marked with \* are optional)

**Flight Instruments**

The flight instruments are installed on the pilot's side of the instrument panel.

**Cabin Heat**

The knob to control the cabin heat is located on the center console below the instrument panel.

knob pulled = cabin heat ON

**Cabin Air**

The cabin aeration is controlled by two adjustable air-vent nozzles. The two sliding/knockout windows in the canopy can be opened for additional ventilation.

Revision No.	Reference	Date October 20, 1993	Page 7 - 5
--------------	-----------	--------------------------	---------------

## 7.5. LANDING GEAR SYSTEM

The landing gear system consists of the two main landing gear wheels mounted to a self-spring steel strut and a free following nose wheel. The suspension of the nose wheel is handled by an elastomer package.

The landing gear wheel fairings are removable. During flight operations without wheel fairings, partially reduced flight performance must be taken into account (see Chapter 5).

### Wheel Brakes

Hydraulically operated disc brakes act on the wheels of the main landing gear. The wheel brakes are operated individually using the toe-brake pedals either on the pilot's or on the co-pilot's side.

### Parking Brake

The knob is located on the center console in front of the throttle quadrant, and is pushed in when the brakes are to be released. To set the parking brake, pull the knob to the stop. Repeated pushing of the toe-brake pedals will build up the required brake pressure which will remain in effect until the parking brake is released.

Revision No.	Reference	Date	Page
		October 20, 1993	7 - 6

## 7.6. SEATS AND SAFETY BELTS

The seats are removable to facilitate the maintenance and inspection of the underlying controls. Covers on the control sticks prevent loose objects to foul the controls.

The seats are equipped with removable cushions. Manually triggered seat-type parachutes may be used instead of cushions. For automatically triggered parachutes it is possible to install suitable fastening loops on the A-bolts (under the seats).

Every seat is equipped with four-point safety belt. The locking of the safety belt occurs by inserting the belt-ends into the belt lock. The belt is opened by rotating the belt lock.

## 7.7. BAGGAGE COMPARTMENT

The baggage compartment is located behind the seat above the fuel tank. The baggage should be distributed evenly in the baggage compartment. The baggage must be secured using the harness provided. The harness attaches to the roll bar.

### CAUTION

Before loading the baggage compartment, check the limits of the baggage and seat loads. More information can be found on the loading diagram.

Revision No.	Reference	Date	Page
		October 20, 1993	7 - 7



## 7.8. CANOPY

### Locking

The canopy is closed by pulling the black handles on the canopy frame. The canopy is locked using the red handles on the left and right side of the frame.

Opening the canopy occurs in reverse order, where the levers are mechanically linked, so that pulling one lever to the stop will cause the other lever to move as well. This is for emergency only.

### **CAUTION**

Before starting the engine, the canopy must be closed and locked. The red handles must be moved fully forward.

## 7.9. POWERPLANT

### Engine

Rotax 912 A3, 4 cylinder, 4 stroke engine, horizontally opposed, liquid cooled cylinder heads, air cooled cylinders.

Propeller drive via integrated reduction gear (crankshaft RPM in parentheses).

Displacement: 1.211 liters (73.9 cu.in.)  
 Max T/O Power (5 min): 59.6 kW / 80 HP at 2550 RPM (5800 RPM)  
 Max Continuous Power: 58 kW / 78 HP at 2420 RPM (5500 RPM)

Additional information can be found in the Engine Operating Manual.

The powerplant instruments are located on the instrument panel on the co-pilot's side.

The ignition switch is present in form of a key switch. The ignition is turned on by turning the key to position BOTH. The starter is operated by further turning against feather load to the right (position START).

### Carburetor Heat, Throttle, Propeller Speed Control Lever

These three functions are grouped together in a single control unit (throttle quadrant) on the center console.

**Carburetor heat:** lever with cubic knob, left of throttle  
 lever backward = ON  
 During normal operation the carburetor heat is OFF (lever forward)

**Throttle:** large lever with cylindrical knob  
 lever full forward = FULL throttle  
 lever full rearward = IDLE

**Propeller speed control lever:** lever with star knob, right of throttle  
 lever forward = max. RPM  
 (also see page 7-10).

**Choke**

Small black knob below the center instrument panel (self-resetting)  
knob pulled = choke ON

**Propeller**

Two-bladed variable pitch propeller, model Hoffmann HO-V72F/S 170DW or HO-V352F/170FQ,  
constant speed, hydraulic pitch control.

**Propeller Governor**

Woodward A 210786 or Woodward A 210786 A.

**Propeller speed adjustment**

Propeller speed adjustments are made with the propeller speed control lever located on the center console (throttle quadrant) to the right of the throttle. Pulling the lever backwards causes a reduction in RPM. The governor keeps the selected RPM constant regardless of airspeed or throttle setting. If the engine power level selected with the throttle is insufficient to keep the selected RPM constant, the propeller blades will move to the smallest possible pitch.

The propeller governor is mounted on the engine. It is driven directly by the engine. The propeller governor oil circuit is part of the engine oil circulation system. A defect in the governor or oil system will cause the blades to run to the minimum pitch position.

Revision No.	Reference	Date	Page
1		December 30, 1994	7 - 10

7.10. FUEL SYSTEM

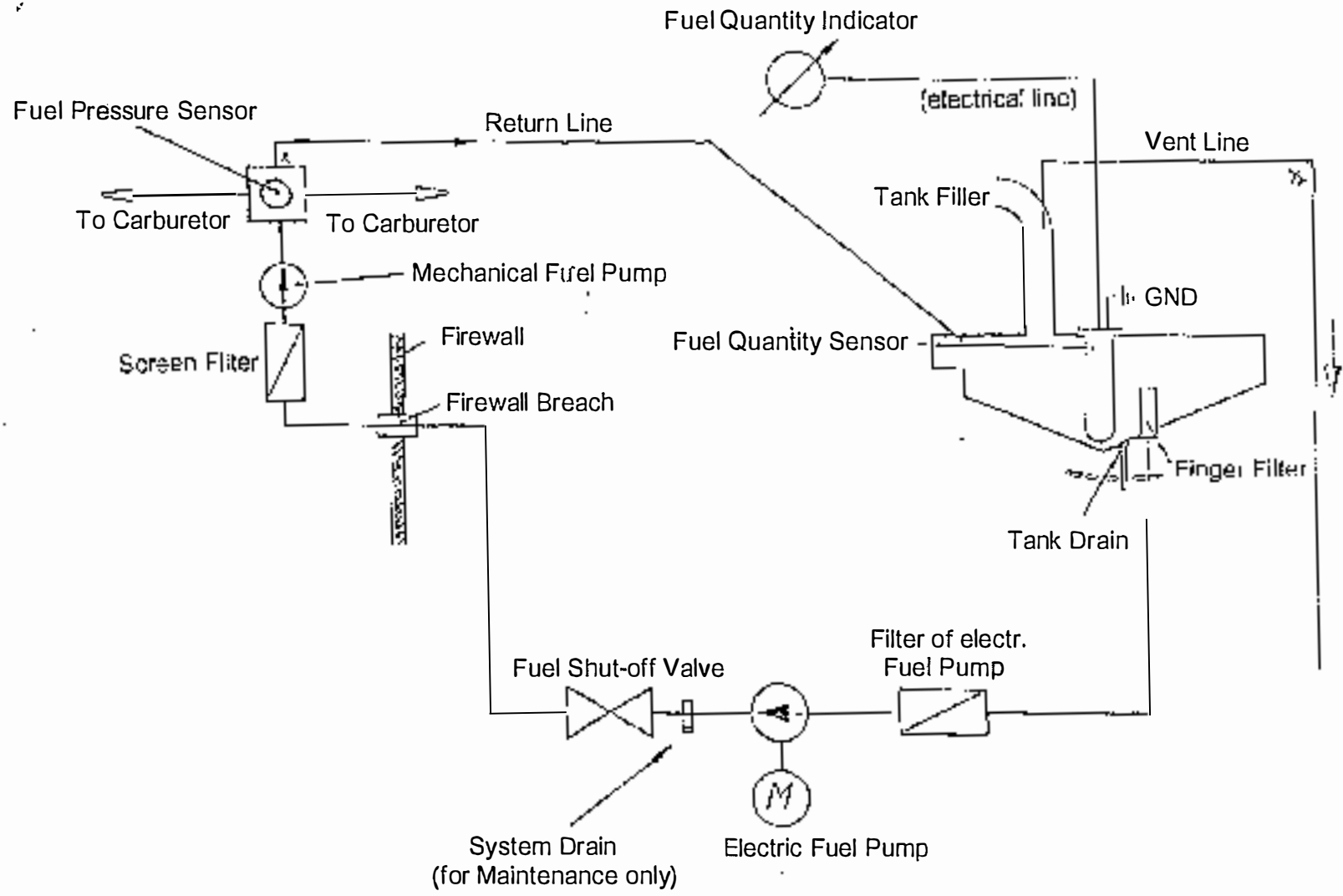

The tank, made from aluminum, is located behind the seats, below the baggage compartment. It holds 79 liters (20.9 US gal.), 77 liters (20.3 US gal.) of which are usable. The tank filler on the left side of the fuselage behind the canopy is connected to the tank with a rubber hose. The tank vent line runs from the filler connection piece through the fuselage bottom skin to the exterior of the airplane.

A finger filter is installed at the bottom of the tank. From there, the fuel is led to the electric fuel pump, and from there through the center console to the fuel shut-off valve. From the fuel shut-off valve it is led to the firewall breach, and further on to the mechanical fuel pump. From there, the fuel reaches the cross-shaped fitting and finally the float chambers of both carburetors. A return line runs from the cross-shaped fitting to the tank. Flexible, stainless steel wire bride coated teflon hoses are used for all fuel lines.

A fuel pressure sensor is installed on top of the cross-shaped fitting. As soon as the fuel pressure drops below 0.1 bar (1.45 psi), the fuel pressure warning light will illuminate.

#### **Electrical fuel pump**

The electrical fuel pump is designed as an emergency pump which is normally not in operation. It is checked for operation during the engine starting procedure and is switched on for take-off and landing to provide additional safety.

#### **Fuel shut-off valve**

The fuel shut-off valve is located on the left hand side of the center console near the pilot's feet. In the open position the tap is parallel to the direction of flight. The valve is protected against unintentional shut-off by a safety device.

### **WARNING**

The fuel shut-off valve should only be closed during engine fire or fuel system maintenance. After reopening, the safety device should be checked to ensure it performs the proper safety function. Otherwise the danger of operating the airplane with the fuel shut-off valve closed (engine failure) is given!

Revision No.	Reference	Date	Page
1		December 30, 1994	7 - 12

**Fuel Drain**

The fuel drain is located at the lowest point of the fuel system. It may be operated for maintenance after opening the handhole lid (in the center of the fuselage bottom).

**Tank Drain**

To drain the tank sump, activate the spring loaded drain by pushing the brass tube in with a drain container. The brass tube protrudes approx. 30 mm (1 1/6 in) from the fuselage contour and is located on the left side of the fuselage, approximately at the same station as the fuel filler cap.

Revision No.	Reference	Date	Page
		October 20, 1993	7 - 13

7.11. ELECTRICAL SYSTEM

Schematic (simplified):

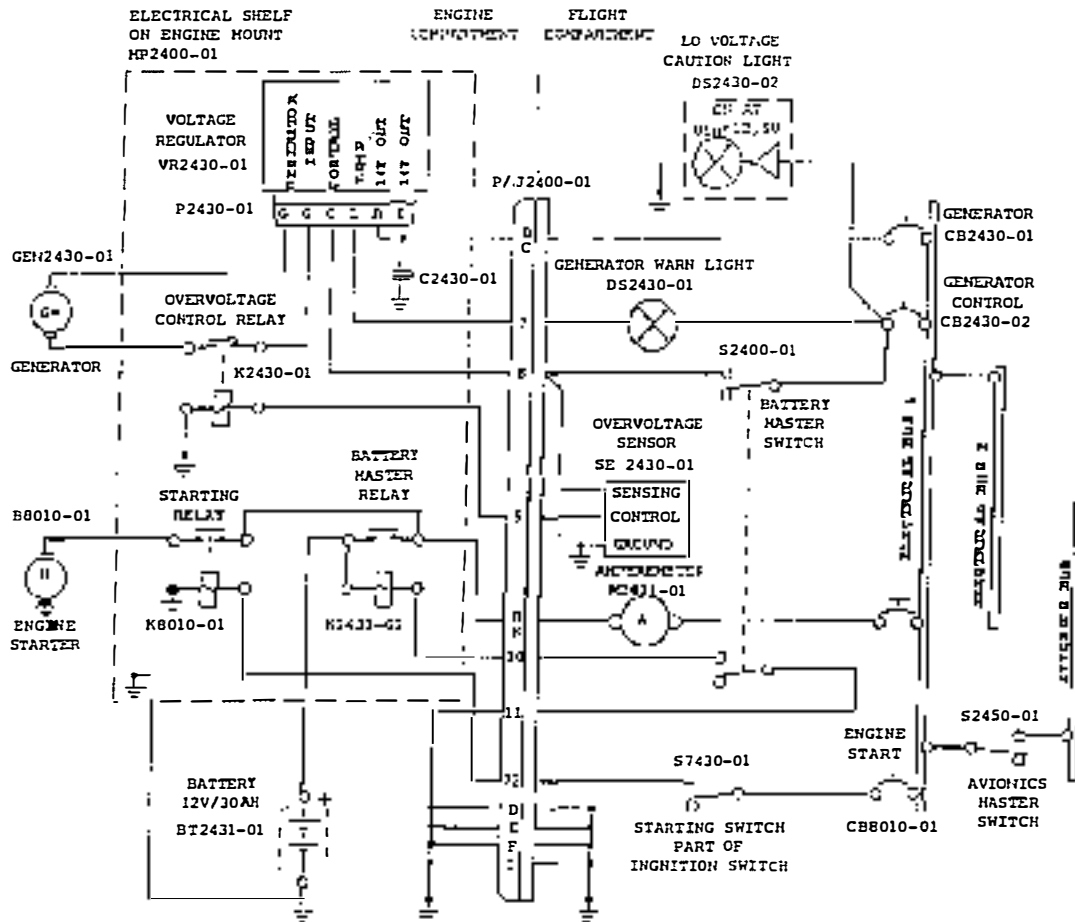

**Power supply**

The battery is connected to the master bus via the master circuit breaker (50 Amps). The generator which is integrated in the engine recharges the battery via the generator circuit breaker (25 Amps). Both circuit breakers can be triggered manually. The generator warning light is fed by the voltage regulator and illuminates when the generator is not charging the battery.

**Ignition System**

The engine is provided with two independent ignition systems. The two magnetos are independent from the rest of the electrical power system, and are in operation as soon as the engine is running. This ensures safe engine operation even in case of an electrical power failure.

**WARNING**

If the ignition key is turned to L, R or BOTH, the respective magneto is "hot". If the propeller is moved during this time the engine may fire and cause serious or fatal injury to personnel.

Revision No.	Reference	Date	Page
		October 20, 1993	7 - 14

### Electrical Consumers

The individual consumers (e.g. radio, fuel pump, position lights, etc.) are connected in series with their respective circuit breakers. Equipment that does not have a switch installed is controlled with a toggle switch in the center section of the instrument panel.

### **CAUTION**

The landing light must not be used for more than 6 min. (but not more than 5 min. continuous use), and the position lights must not be used for more than 30 min. per airplane operating hour.

At non-observation of this limitation, full charge of the battery is not ensured.

### Low Voltage Caution Light

This caution light illuminates when the airplane voltage drops below 12.5V. The color is amber. This indicates that the situation should be noted, but no immediate action is necessary.

### Generator Warning Light

The generator warning light (color: red) illuminates during:

- Generator failure
- Regulator failure, overvoltage may be fed into the electrical system. In this case the generator is automatically disconnected from the system.

After both occurrences, the only remaining power source is the battery (capacity: 30 amp.hrs.).

### Ammeter

The ammeter shows the intensity of the current with which the battery is being charged (positive range) or discharged (negative range).

### Fuel Pressure Indicator

As soon as the fuel pressure drops below 0.1 bar (1.45 psi), the fuel pressure switch closes, and the fuel pressure warning light illuminates.

Revision No. 1	Reference	Date December 30, 1994	Page 7 - 15
-------------------	-----------	---------------------------	----------------



### Instruments

The instruments for temperatures, oil pressure, and fuel quantity are connected in series with the respective sensors. The electrical resistance of a sensor changes with the measurable variable, which causes the power to the instrument and consequently the needle deflection to change. Oil pressure indicator, cylinder head temperature indicator and fuel pressure warning light are supplied with power through one circuit breaker. Oil temperature indicator and fuel quantity indicator are also protected together by one circuit breaker.

### 7.12. PITOT AND STATIC PRESSURE SYSTEMS

The total head is measured on the leading edge of a calibrated probe below the left wing. The static pressure is measured by the same probe using two holes in the lower edge and rear edge of the probe. For protection against dirt and humidity, filters are installed in the line. These filters are accessible beneath the left seat.

The error of the static pressure system is small enough to be neglected for the measuring of the altitude. For the error of the airspeed indicating system refer to Chapter 5.

### 7.13. STALL WARNING SYSTEM

When the airspeed drops below 1.1 times the stall speed, a horn sounds in the left instrument panel. The horn grows louder as the speed approaches the stall speed. The horn is activated by suction on a hose that leads from a hole in the leading edge of the left wing to the horn. The hole is marked by a red circle around.

### 7.14. AVIONICS

The center of the instrument panel contains the radio and navigation equipment. The microphone key for the radio is installed in the control stick. There are two connectors for headsets on the backrest of the seat.

Operating instructions for individual avionics equipment should be taken from the manuals of the respective manufacturers.

Revision No.	Reference	Date October 20, 1993	Page 7 - 16
--------------	-----------	--------------------------	----------------

## CHAPTER 8

# HANDLING, PREVENTIVE AND CORRECTIVE MAINTENANCE

<b>8.1. INTRODUCTION</b>	<b>8-2</b>
<b>8.2. AIRPLANE INSPECTION PERIODS</b>	<b>8-2</b>
<b>8.3. AIRPLANE ALTERATIONS OR REPAIRS</b>	<b>8-2</b>
<b>8.4. GROUND HANDLING / ROAD TRANSPORT</b>	
8.4.1. Towing	8-3
8.4.2. Parking	8-3
8.4.3. Mooring	8-3
8.4.4. Jacking	8-4
8.4.5. Alignment	8-4
8.4.6. Road Transport	8-5
<b>8.5. CLEANING AND CARE</b>	
8.5.1. Painted Exterior Surfaces	8-6
8.5.2. Canopy	8-6
8.5.3. Propeller	8-7
8.5.4. Engine	8-7
8.5.5. Interior Surfaces, Seats and Carpets	8-7

Revision No.	Reference	Date October 20, 1993	Page 8 - 1
--------------	-----------	--------------------------	---------------

## 8.1. INTRODUCTION

This Chapter contains factory-recommended procedures for proper ground handling and servicing of the airplane. It also identifies certain inspection and maintenance requirements which must be followed if the airplane is to retain that new-plane performance and dependability. It is wise to follow a planned schedule of lubrication and preventive maintenance based on climatic and flying conditions encountered.

## 8.2. AIRPLANE INSPECTION PERIODS

Inspection intervals are every 100 hrs., 200 hrs. and 600 hrs. of flight time. The respective maintenance procedure can be found in the Engine Manual or the Airplane Maintenance Manual.

## 8.3. AIRPLANE ALTERATIONS OR REPAIRS

It is essential that the responsible airworthiness authority be contacted prior to any alterations on the airplane to ensure that airworthiness of the airplane is not violated. For repairs refer to the applicable Maintenance Manual Doc. No. 4.02.02.

Revision No.	Reference	Date	Page
2	SB 20-18	May 23, 1995	8 - 2

## 8.4. GROUND HANDLING / ROAD TRANSPORT

### 8.4.1. Towing

The airplane is most easily and safely maneuvered by hand with the tow-bar attached to the nose wheel.

If no tow-bar is used, during forward traversing the nose-wheel will follow the movement of the airplane. Change in direction is achieved by pulling on the propeller hub. To traverse in the rear direction, the tail section of the airplane should be pushed down until the nose-wheel is clear of the ground. This method can also be used to turn the airplane around its main landing gear.

### 8.4.2. Parking

For short time parking, the airplane must be orientated in headwind direction, the parking brake must be engaged and the wing flaps must be in the retracted position. For extended and unattended parking, as well as in unpredictable wind conditions, the airplane must be anchored to the ground or placed in a hangar. Parking in a hangar is recommended.

### 8.4.3. Mooring

The tail fin of the airplane has a hole which can be used to tie-down the airplane to the ground. Also on each end of the wings an eyelet can be installed and used as tie-down points.

Revision No.	Reference	Date	Page
		October 20, 1993	8 - 3

#### 8.4.4. Jacking

The DV 20 KATANA can be jacked at the two jackpoints located on the lower side of the fuselage's root ribs well as at the tail fin.

#### 8.4.5. Alignment

For alignment push down on the tail section at the fuselage/rudder fin junction, until the nose-wheel is clear of the ground. With the nose-wheel free, the DV 20 KATANA can be turned and aligned in any position around the main landing gear. After turning the airplane into the correct position, the tail section can be slowly released until the nose wheel is back on the ground.

Revision No.	Reference	Date	Page
		October 20, 1993	8 - 4

#### 8.4.6. Road Transport

For transporting the airplane on the road, it is recommended to use an open trailer.

All airplane components must be stored on a cushioned surface and secured to avoid any movement during transporting.

##### 1. Fuselage:

The fuselage should be stored on the trailer standing on its wheels. It must be ensured that the fuselage will not move in forward, backward or upward direction. Furthermore it must be ensured that the propeller has sufficient free space so it cannot be damaged in case the fuselage should move.

##### 2. Wings:

For transportation, both wings must be removed from the fuselage.

To avoid any damage, the wings are stored in upright position on the leading edge with the root rib area positioned on an upholstered profiled surface of at least 400 mm (1 ft 3.75 in) width. The outside wing area (approximately 3m (10 ft) from the root rib area) is placed on an upholstered profiled surface of a minimum of 300 mm (11.81 in) width.

The wings must be secured to avoid any sliding movement to the rear.

##### 3. Elevator

The elevator is stored flat on the trailer and secured, or in an upright position sitting on the leading edge on a profiled surface. All storing surfaces must be upholstered with felt or cellular rubber.

Revision No.	Reference	Date	Page
		October 20, 1993	8 - 5

## 8.5. CLEANING AND CARE

### CAUTION

Excessive dirt deteriorates the flight performance.

#### 8.5.1. Painted Surfaces

The entire surface of the airplane is painted with a white weather proof two component laquer. Nevertheless, the airplane should be protected against moisture and dampness. The aeroplane should not be stored outdoor for long periods of time. Water that has accumulated must be removed by storing the affected parts in a dry place and turning them over several times.

Dirt, insects, etc. can be removed with clear water and if necessary with a mild detergent. An automotive paint cleaner can be used for stubborn spots. For best results, clean the aeroplane after the day's flying is ended, so that the dirt will not become engrained.

Oil stains, exhaust stains etc. on the lower fuselage skin can be removed with a cold detergent. Before you start, make sure the detergent does not damage the paint finish. Use commercial automotive preservatives to conserve the paint finish.

#### 8.5.2. Canopy

Canopy and windows should be cleaned with PLEXICLEAR or any other Plexiglas detergent if available; otherwise use lukewarm water. Final cleaning should be done with a clean piece of doeskin or soft cloth. Never rub or polish dry plexiglass!

Revision No.	Reference	Date	Page
		October 20, 1993	8 - 6

### 8.5.3. Propeller

See Hoffmann Propeller Instruction Manual E243 (HO-V72) or E540 (HO-V352).

### 8.5.4. Engine

See Operator's Manual for the Rotax 912 A aircraft engine.

### 8.5.5. Interior Surfaces, Seats and Carpets

The interior should be cleaned using a vacuum cleaner. All loose items (pens, bags etc.) should be properly stored and secured. All instruments can be cleaned using a soft dry cloth, plastic surfaces should be wiped clean using a damp cloth without any cleaning agents.

Revision No.	Reference	Date	Page
		October 20, 1993	8 - 7



## CHAPTER 9

### SUPPLEMENTS

| At this time the following Supplements are available:

|

- |                  |                                    |
|------------------|------------------------------------|
| Supplement No. 4 | Operation in Russia                |
| Supplement No. 5 | Operation with a Winterization Kit |

Revision No.	Reference	Date	Page
1		20 May 1997	9 - 1