

# BD-5B/D/G

## PILOT'S HANDBOOK

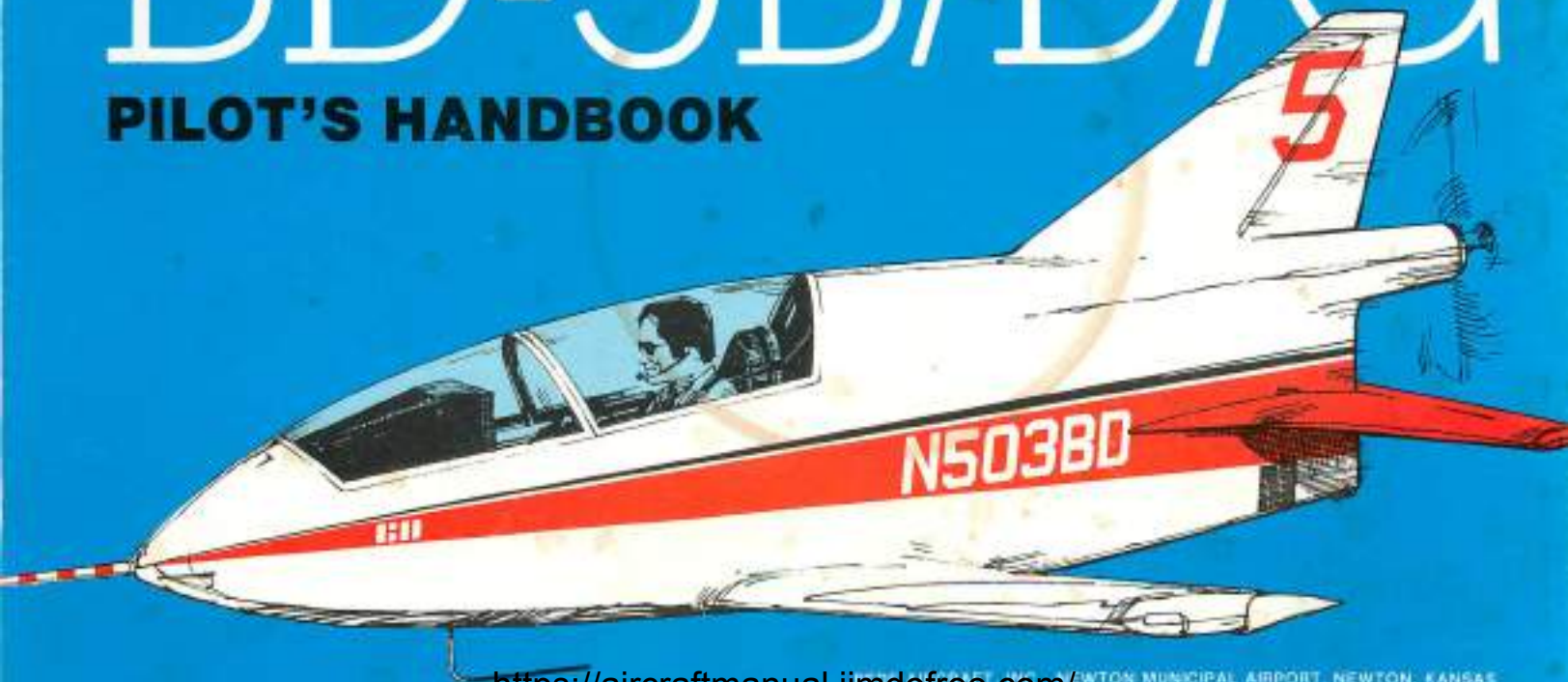

<https://aircraftmanual.jimdofree.com/> NEWTON MUNICIPAL AIRPORT, NEWTON, KANSAS

<https://aircraftmanual.jimdofree.com/>

## TABLE OF CONTENTS

Section 1	Description . . . . .	1-1	Section 6	Flight Characteristics . . . . .	6-1
Section 2	Normal Procedures . . . . .	2-1	Section 7	Systems Operation . . . . .	7-1
Section 3	Emergency Procedures . . . . .	3-1	Section 8	All Weather Operation . . . . .	8-1
Section 4	Auxiliary Equipment . . . . .	4-1	Appendix A	Performance Charts and Glossary . . .	A-1
Section 5	Operating Limitations . . . . .	5-1	Appendix B	Initial Checkout . . . . .	B-1

## FOREWORD

### SCOPE

This Pilot's Handbook contains the information necessary for the safe and efficient operation of the BD-5B, BD-5D and HD-5G aircraft. These instructions provide you with a general knowledge of the aircraft, normal and emergency operating procedures, limitations, flight characteristics, performance data, maintenance procedures and initial checkout. It is assumed that your flight proficiency is at least equivalent to that required for the issue of a private pilot's license; therefore, basic flight principles are not discussed.

### OPERATOR JUDGEMENT

This handbook provides the best possible operating instructions under most circumstances, but it is not a substitute for sound judgment. Multiple emergencies, adverse weather, terrain, etc., may require deviations from the recommended procedures.

### PERMISSIBLE OPERATIONS

This Pilot's Handbook takes a "positive approach" and normally states only what you can do. Unusual operations or configurations (objects attached to the outside of the aircraft, flight with canopy removed, etc.) are not recommended unless specifically covered herein. Advice should be obtained from Bede Aircraft, Inc. before any questionable operation is attempted.

### OPERATIONAL AND FLIGHT SAFETY SUPPLEMENTS

Information concerning safety will be promptly forwarded to you in the form of Pilot's Handbook supplements. Card is enclosed in the back of the manual for you to order 1 year supplement service subscription for \$5000. You should remain constantly aware of the status of all supplements to stay current on the latest information.

## WARNING, CAUTIONS, AND NOTES

The following definitions apply to warnings, cautions, and notes found throughout the handbook.

**WARNING** - Operating procedures, practices, etc., which will result in personal injury or loss of life if not carefully followed.

**CAUTION** - Operating procedures, practices, etc., which if not strictly observed will result in damage to or destruction of equipment.

**NOTE** - An operating procedure, condition, etc., which it is considered essential to emphasize.

## TECHNICAL CHANGES

To help you find technical changes that otherwise might be inconspicuous, the following will be used as identifiers.

- Change bars, located in the outer margins, will be used to identify changes in text.
- Miniature pointing hands will be used to identify changes in illustrations.

## HOW TO OBTAIN COPIES

Every pilot should have a personal copy of the Pilot's Handbook with all current Operational and Safety of Flight Supplements. This handbook may be ordered from Bede Aircraft, Inc., Newton Municipal Airport, Newton, Kansas 67114 - Attn: Pilot's Handbook Publications. Your handbook, with one year supplement subscription service, will be mailed to you, postpaid.

## YOUR RESPONSIBILITY - TO LET US KNOW

Every effort is made to keep the Pilot's Handbook current. Review conferences with operating personnel and constant reviews of accident and flight test reports assure inclusion of the latest data in the handbook. However, we cannot correct an error unless we know of its existence. In this regard, it is essential that you do your part. Comments and questions regarding this handbook are welcomed.

## FIGURE LIST

Figure 1-1	Left Console .....	1-3	Figure 5-1	Instrument Markings and Operating Limitations Placard .....	5-3
Figure 1-2	Instrument Panel .....	1-5	Figure 5-2	VN Diagram .....	5-4
Figure 1-3	Right Console .....	1-7	Figure 5-3A	Weight and Balance .....	5-7
Figure 1-4	Power Transmission System .....	1-8	Figure 5-3B	Weight and Balance Sample (BD-5B) .....	5-8
Figure 1-5	Fuel System .....	1-10	Figure 5-3C	Weight and Balance .....	5-9
Figure 1-6	Rudder Pedals .....	1-11	Figure 5-3D	Weight and Balance .....	5-10
Figure 1-7	Landing Gear Lever .....	1-12	Figure 8-1	VOR Approach .....	8-5
Figure 1-8	Canopy/Suspension System .....	1-14	Figure 8-2	PAR Approach .....	8-6
Figure 1-9	Electrical System .....	1-15	Figure 8-3	ILS Approach .....	8-7
Figure 2-1	Diagram of Preflight Inspection Route .....	2-3	Figure A-1	Temperature Conversion Chart .....	A-2
Figure 2-2	Diagram of Normal Landing Pattern .....	2-13	Figure A-2	Density Altitude Chart .....	A-3
Figure 2-3	Diagram of Go-Around .....	2-16	Figure A-3	Speed Power Charts .....	A-4
Figure 3-1	Glide Distance Chart .....	3-8	Figure A-4	Fuel Flow Chart .....	A-5
Figure 3-2	Diagram of Forced Landing Pattern .....	3-7	Figure A-5	Takeoff Distance Chart .....	A-6
Figure 4-1	Diagram of Heating and Ventilation System .....	4-2	Figure A-6	Rate of Climb Chart .....	A-7
Figure 4-2	Diagram of Upper Center Console .....	4-3	Figure A-7	Endurance Chart .....	A-9
			Figure A-8	Range Chart .....	A-10
			Figure A-9	Landing Distance Chart .....	A-11
			Figure A-10	Stall Speeds Chart .....	A-12

## SECTION 1—DESCRIPTION

---

### CONTENTS

<b>Aircraft</b> .....	<b>1-2</b>	<b>Flight Control System</b> .....	<b>1-9</b>
<b>Engine</b> .....	<b>1-2</b>	<b>Landing Gear System</b> .....	<b>1-11</b>
<b>Engine Controls</b> .....	<b>1-3</b>	<b>Wheel Brake System</b> .....	<b>1-13</b>
<b>Engine Instruments</b> .....	<b>1-4</b>	<b>Instruments</b> .....	<b>1-13</b>
<b>Ignition System</b> .....	<b>1-6</b>	<b>Canopy</b> .....	<b>1-14</b>
<b>Carburation</b> .....	<b>1-6</b>	<b>Electrical System</b> .....	<b>1-14</b>
<b>Engine Cooling</b> .....	<b>1-6</b>	<b>Exterior Lighting</b> .....	<b>1-16</b>
<b>Power Transmission System and Propeller</b> .....	<b>1-6</b>	<b>Interior Lighting</b> .....	<b>1-16</b>
<b>Fuel System</b> .....	<b>1-9</b>	<b>Baggage Space</b> .....	<b>1-16</b>

## AIRCRAFT

The BD-5D/G is a high-performance, single-place, low-wing, all-metal, pusher-configuration sport aircraft built by Bede Aircraft, Inc. The BD-5B is essentially the same aircraft except for the 21.5 wing length. The BD-5B and BD-5G is manufactured by individual homebuilders with materials and specifications provided by Bede Aircraft, Inc. The aircraft were designed to day-VEF requirements for use in sport and recreational flying, including limited aerobatic capability.

### Dimensions

The overall dimensions of the aircraft are as follows:

#### Wing Span

BD-5B . . . . . 21.5 feet  
 BD-5D/G . . . . . 17.0 feet

Length . . . . . 13.3 feet

Height (at rest) . . . . . 4.2 feet

### Gross Weight

The normal gross weight of the aircraft is BD-5D/G 850 lbs; BD-5B, 710 lbs. For factors affecting gross weight limitations refer to Section 5.

## ENGINE

The aircraft is powered by a Xenosah 726 cc, three-cylinder, air-cooled, two-cycle engine which develops 65 horsepower at 6250 rpm at sea level. The engine is equipped with a direct-drive starter and three float carburetors, and two pulse-type fuel pumps. Model designation of the engine is G72C. Some BD-5B aircraft are equipped with a 650 cc Hirth engine, 45 horsepower, Model designation F20BA1.



## ENGINE CONTROLS

Primary engine controls are conveniently located on the console on the left side of the cockpit.

### Throttle

The throttle (Figure 1-1) located on the left hand console is CLOSED aft, OPEN forward, and can be placed in any intermediate position for a desired power setting. A microphone button, for radio transmission, is located on top of the throttle handgrip if your aircraft is radio equipped. Retarding the throttle to idle actuates the landing gear warning switch which sounds a warning horn and turns on the panel warning light when the landing gear is not down (BD-5D only).

### Mixture Control

The ratio of the fuel-air mixture delivered by the carburetor to the engine is controlled by the air-bleed mixture knob on the left console (Figure 1-1). Turning the knob fully clockwise provides the richest fuel mixture. See Section 7 for mixture operation.

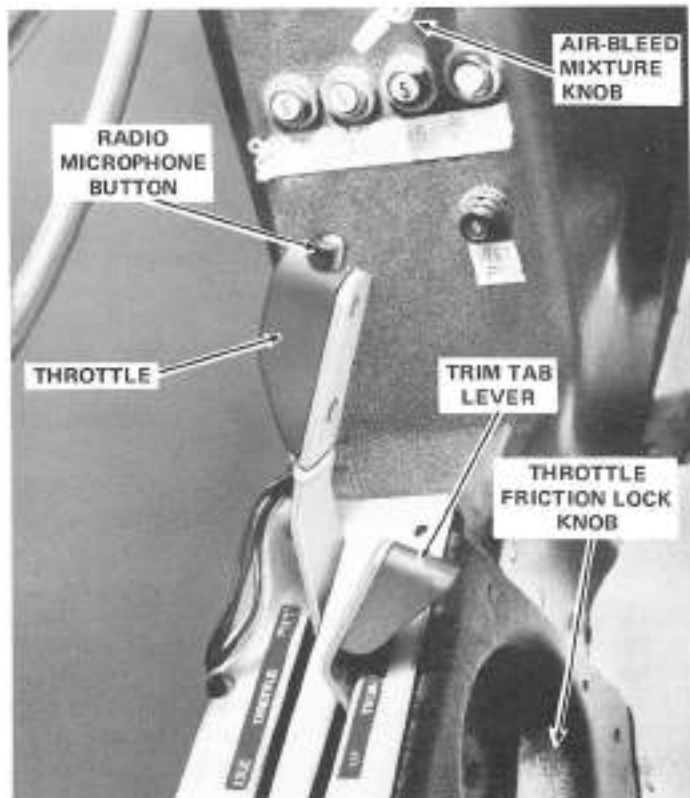

Figure 1-1 Left Console

**Enrichment Valve (Choke)**

The starting enrichment control is a single knob on the right console which is connected to an enrichment valve in each carburetor metering system.

**Throttle Friction Lock**

The throttle friction lock knob is located on the in-board side of the left console (Figure 1-1). The friction lock knob can be rotated clockwise to increase friction and to prevent creeping of the throttle; counterclockwise rotation decreases friction and allows free movement.

**ENGINE INSTRUMENTS**

All of the engine instruments are located on the right side of the instrument panel (Figure 1-2) and provide indications of engine operation or condition.

**Tachometer**

The tachometer is located on the center, right-hand side of the instrument panel (Figure 1-2). The tachometer indicates engine speed in hundreds of revolutions per minute (rpm) and is energized by the engine's alternator coil, independent of the ignition system.

**Cylinder Head Temperature Gage**

The cylinder head temperature (CHT) gage is located on the right hand side of the instrument panel (Figure 1-2). Cylinder head temperature is detected by a thermocouple in the center cylinder head and is registered in degrees Fahrenheit. The CHT system is self-generating and independent of the aircraft electrical system.

**Fuel Pressure Gage**

BD-5D aircraft have a fuel pressure gage as standard equipment (it is optional on BD-5B, BD-5C aircraft). The fuel pressure gage is located on the left console and indicates the fuel pressure at the carburetor pressure chamber in pounds per square inch (psi). Minimum fuel pressure is 0.7 psi at idle and 4.5 psi at 6200 rpm. A failure of one pulse pump will result in a gage indication half of normal pressure.

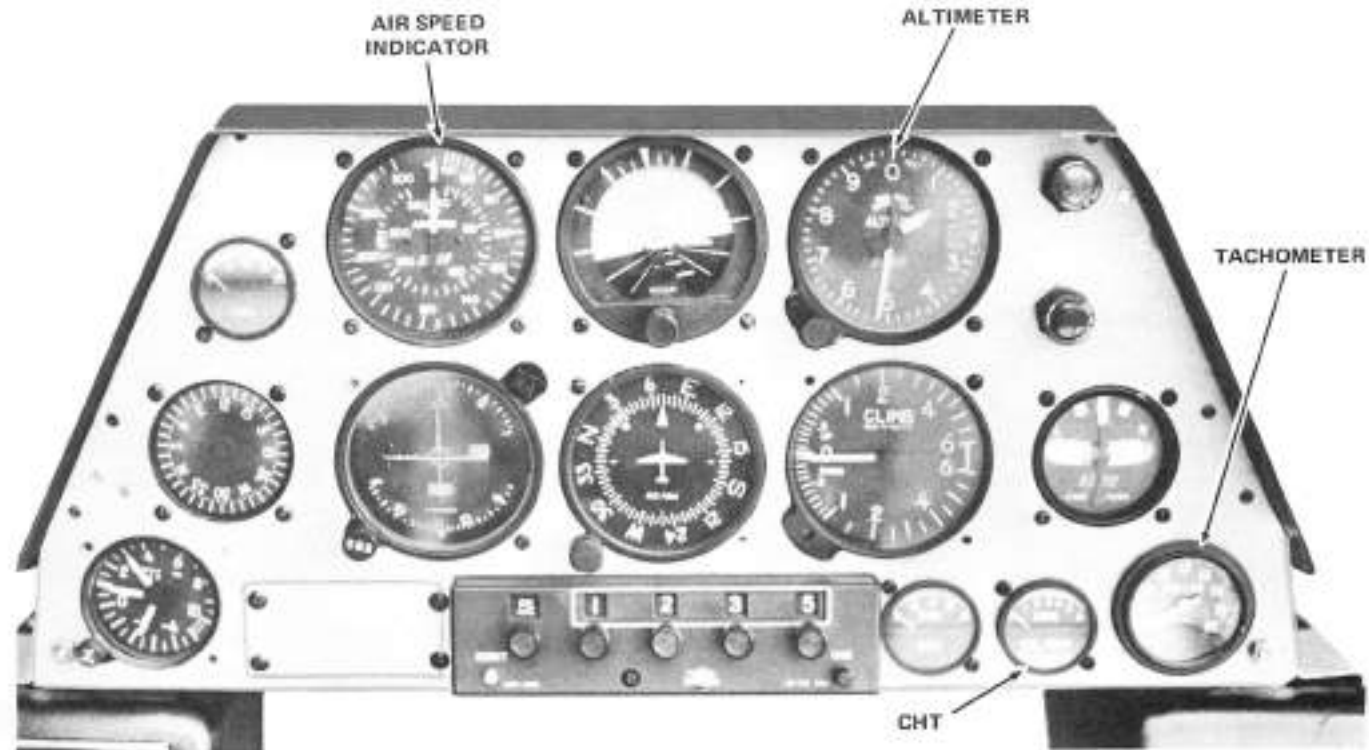

Figure 1-2 Instrument Panel

## IGNITION SYSTEM

Ignition is supplied by two individual capacitance discharge (CD) units which are grounded individually through the ignition switches. Each CD unit provides a high intensity spark to all three cylinders.

The ignition switches are located on the right hand console (Figure 1-3). The starter button is spring loaded to the OFF position. Actuation of the switch to ON energizes the starter relay, which in turn completes the circuit to the direct-cranking electric starter. The starter is automatically engaged when the button is pushed and disengaged when the starter button is released. Electrical power for the operation is supplied directly by the main dc bus. The master switch must be on for starter operation.

## CARBURETION

The aircraft is equipped with three float-type, single-barrel, side-draft carburetors. The carburetors are located in a fireproof box on the right side of the engine and are isolated from the rest of the engine compartment. The engine is equipped with two pulse-

type fuel pumps which use oscillating crankcase pressure to provide the pumping action. The pumps are interconnected so that one pump can supply pressure to all carburetors in the event of one pump or pulse line failure.

## ENGINE COOLING

Cooling of the engine is provided by an external ram scoop which, by means of baffling, forces air over the exhaust system, around the cylinder fins and dumps it into the upper engine compartment. The cooling air then circulates around the drive system and is ejected from the aircraft with the engine exhaust under the aft portion of the fuselage by the exhaust ejector.

## POWER TRANSMISSION SYSTEM AND PROPELLER

Figure 1-4 shows the power transmission system which connects the engine to the propeller. The lower shaft connects the engine to the lower pulley through two soft rubber couplings which isolate engine vibration from the drive system. A "high torque"



Figure 1-3 Right Console

round-tooth belt is used to drive the upper pulley at 0.625 times the engine rpm. This "gearing down" allows the propeller to run at its most efficient cruise rpm and provides greater thrust for takeoff. Housed within the top pulley is a one-way clutch which allows the propeller to freewheel in one direction. This eliminates all drive system vibration during start-up and shut-down and allows limited soaring flight with the engine shut down, with only a very slight propeller aerodynamic drag. The upper shaft is supported in its outer tube housing with four sealed bearings. The propeller is a 46-inch diameter fixed-pitch, wood design which features fatigue-free safety and light weight. The standard propeller for the BD-5B/DG has a pitch of 53 inches, which gives good take off and climb performance while maximizing cruise speed at 8000 feet. A lower pitch propeller is also available as an option to increase climb and take off performance with a moderate decrease in cruise speed. A ground adjustable propeller also is available which enables pilot selection of pitch (pitch can only be set on the ground prior to engine start up).

Figure 1-4 Power Transmission System

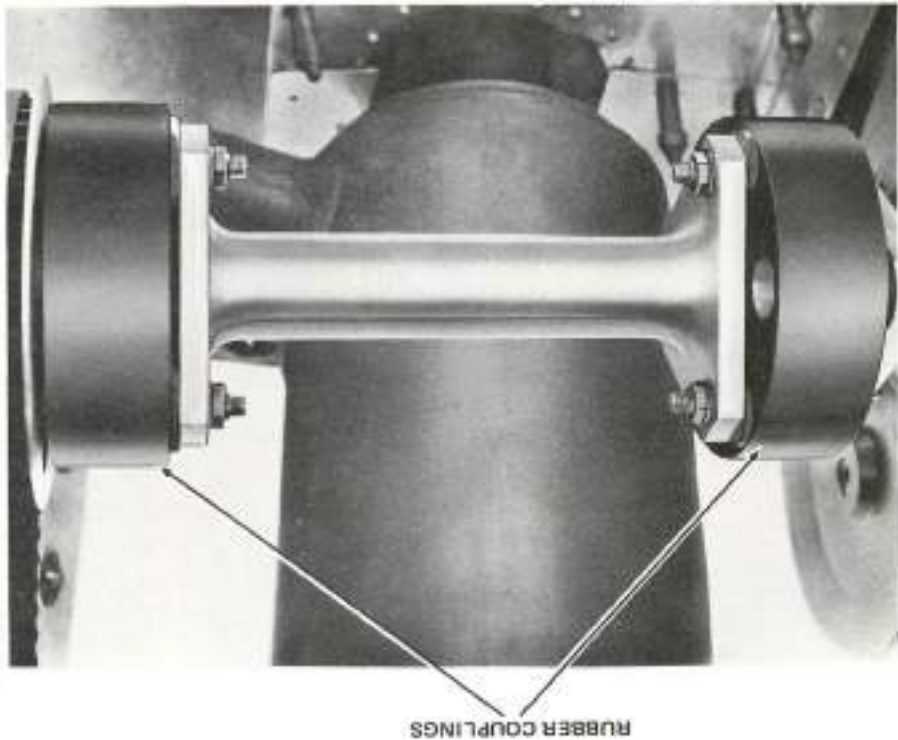

## FUEL SYSTEM

The fuel system (Figure 1-5) consists of two wing tanks, a fiber optic fuel gage, servicing caps, a manual fuel selector valve and a fuel filter. The system is a 'left-right-off' system. Total fuel quantity is 29 gallons, of which 28 is available on BD-5D/G, (26 gallons, of which 24.5 is available on BD-5B). The first wing fuel bay is closed off (except for a small fuel feed hole in the outboard rib) to prevent loss of fuel flow when sideslipping into the wing being used.

## FLIGHT CONTROL SYSTEM

The primary flight control surfaces (ailerons, rudder, and elevator) are operated by a "wrist-action" side stick on the right console and by rudder pedals (Figure 1-6). A trim tab on the stabilator is mechanically operated by a lever on the left console.

### Rudder Pedals

The rudder pedals, which also include toe brakes, are not adjustable. Individual seat-to-pedal adjustment is provided by fore-and-aft movement of each seat, or by the size of seat cushions.

### Trim Tabs

Trim tabs are installed on all flight control surfaces. The aileron and rudder tabs can be adjusted on the ground only, while stabilizer trim tab is a cockpit adjustable anti-servo type. As the stabilator is displaced from neutral, the tab moves in the same direction, increasing stabilizer effectiveness and the force required to deflect it. This feature provides stabilizer control "feel."

### Stabilizer Trim Tab Lever

The stabilizer trim tab lever is located on the left console (Figure 1-1). Movement of the lever forward raises the tab, "flies" the stabilator nose up, and lowers the nose of the aircraft; movement aft lowers the tab and raises the nose of the aircraft. Take off position of the trim lever is with the lever one-third of the way forward in its slot.

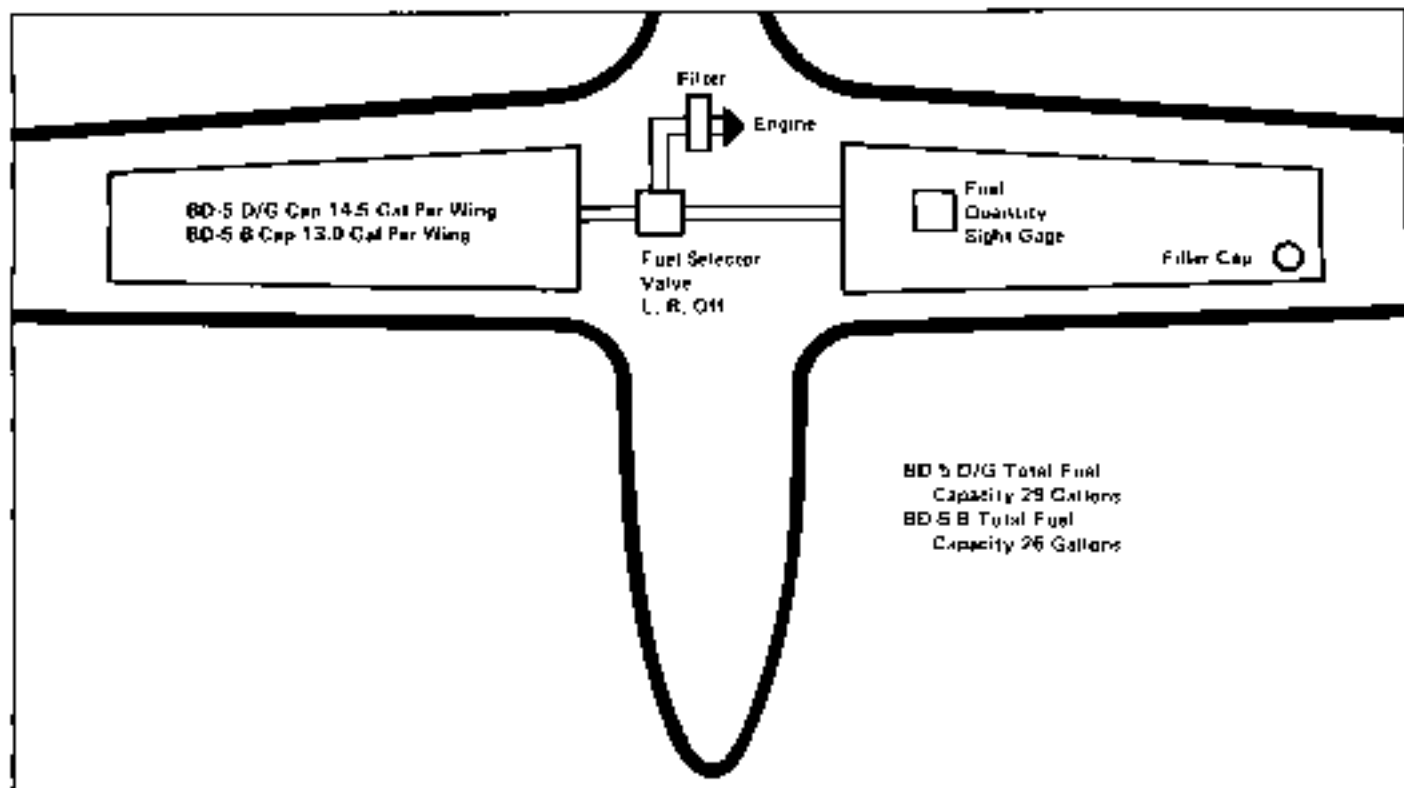

Figure 1-6 Fuel System



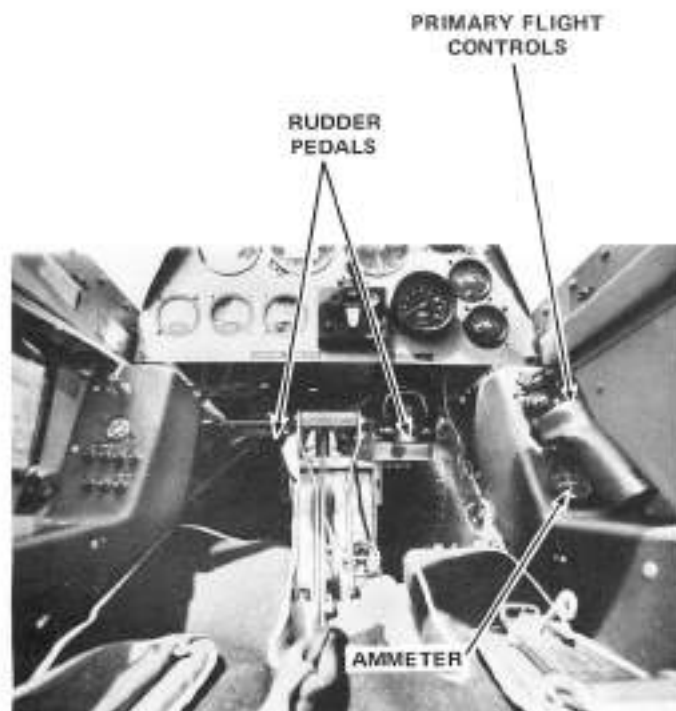

Figure 1-6 Rudder Pedals

### Wing Flaps

Manually operated plain flaps extend from the wing root to the aileron on each wing. The flaps are operable from the cockpit by a handle located between the pilot's legs. The handle is pulled forward for flaps up, and pulled aft to lower the flaps. Two flap-down positions are provided: a takeoff position of 20 degrees and a landing position of 40 degrees. The handle must be pulled left to unlock before changing flap position.

### LANDING GEAR SYSTEM

The manually operated tricycle landing gear is fully retractable. The main wheels retract inboard into the center fuselage and the nosewheel retracts aft into the forward fuselage. Fairing doors, operated by gear movement, fully cover all wheels when retracted. No downlocks or uplocks are provided since the offset, or over-center pivot, of the linkage provides a geometric locking effect. The linkage is also spring loaded to the offset position. Steering on the ground at low speeds is accomplished by differential braking, since the nosewheel is free to pivot. The landing gear handle is located between the pilot's legs under the

instrument panel, to the right of the flap handle (Figure 1-7). The handle is mechanically connected by cables to the retraction linkages of all three landing gear. Moving the handle forward extends the landing gear and positions the linkages over center, locking the gear down. Moving the handle aft retracts the landing gear and again positions the linkages over center, locking the gear up. Springs at each landing gear linkage serve to hold the gear in the locked position and to overcome its weight, making retraction easier, thus, no separate locking action is required by the pilot. The gear can be retracted or extended in about one second by merely pulling or pushing the handle with a smooth 15 lb. stroke.

#### Landing Gear Position Indicators

The position of the landing gear is shown by the position of the landing gear handle, and by the gear position indicator lights. Pushing the gear handle forward against its stop assures that all gear are locked down. The landing gear down indicating light system will indicate three green lights when the gear is down and locked.

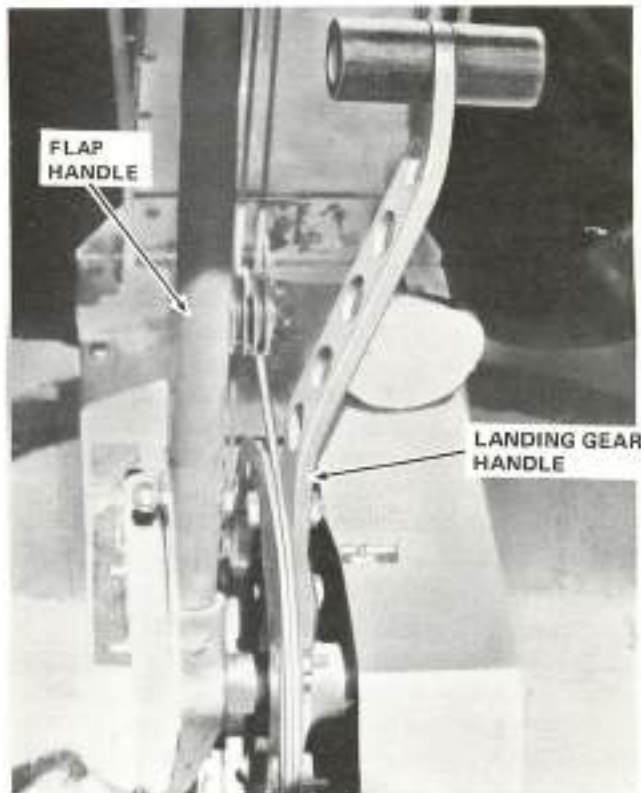

Figure 1-7 Landing Gear Lever

### **Landing Gear Warning Horn**

Retarding the throttle to idle with the gear not fully extended and locked will sound the horn. The landing gear warning horn and light operate directly from the aircraft's main DC bus (BD-5D only).

## **WHEEL BRAKE SYSTEM**

The main landing wheels are equipped with hydraulic brakes, operated by toe pressure on the rudder pedals. Fluid from a reservoir supplies a master cylinder located at each pedal. Toe action on the rudder pedals actuates the cylinder, and applies brake pressure to the corresponding wheel. For operation of the wheel brake system, refer to Section 7.

## **INSTRUMENTS**

The instruments described herein are those supplied as standard equipment.

### **Pitot Static System**

The airspeed indicator and altimeter are operated by the pitot static system. This system is composed of a pitot tube, mounted on the fuselage nose, and static air pressure ports which are located in the skin on

both sides of the fuselage. A noseboom, available as optional equipment, provides both a pitot and static pressure source with a more accurate calibration than the basic system. The noseboom is removable by twisting it to the left and pulling forward.

### **Altimeter**

A conventional, sensitive altimeter is installed on the instrument panel (Figure 1-2) for use in determining the indicated altitude of the aircraft above sea level. The altimeter functions on static pressure alone and is equipped with three pointers which are used to indicate values of altitude as they pass over a dial graduated in units of feet. A barometric dial is also incorporated in the instrument and may be set in conjunction with the altitude pointers by an external adjusting knob. Adjustment is made with the knob so that the reading on the barometric dial will correspond to the sea level barometric pressure in the area in which the aircraft is located.

### **Airspeed Indicator**

The airspeed indicator (Figure 1-2) operates by pressure differential between pitot tube impact pressure and static pressure, and is calibrated in mph/kts BD-5D, mph only BD-5B/G.

## CANOPY

The canopy is made up of two sections, the windshield and a movable aft portion. The aft portion opens up and aft on a three-beam suspension system for normal crew entry (Figure 1-8). The forward section is a fixed windshield which is removable for access to avionics, brakes, and rudder pedals. The canopy latch is at the top of the forward canopy bow. The canopy is latched by first pulling the canopy rails down firmly along the sides (crossed arms works best), rotating the handle to the right and pushing down and forward, then rotating the handle to the left to lock.

## ELECTRICAL SYSTEM

The basic electrical power distribution system (Figure 1-9) is a 12-volt, direct-current (DC) single-wire system, using the aircraft's structure for a ground return. All equipment powered from the aircraft's electrical system is DC. All circuits except the starter are protected by circuit breakers.

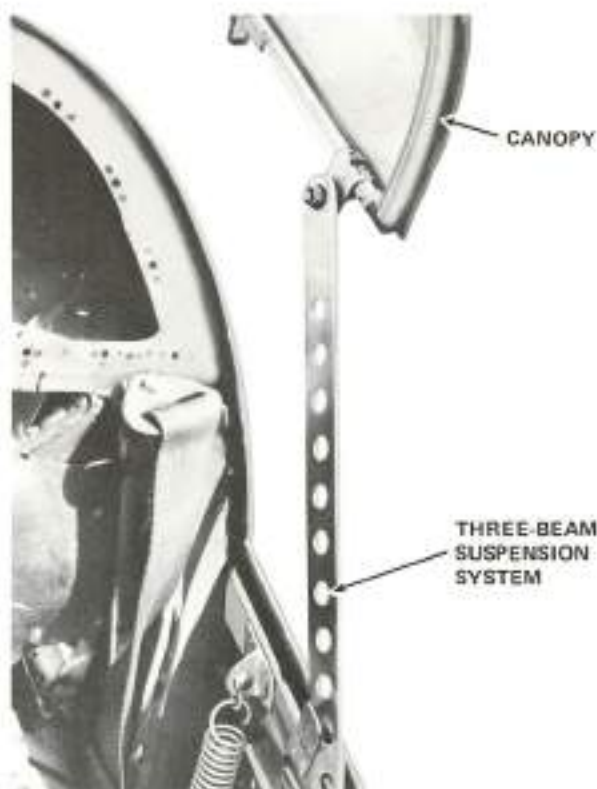

Figure 1-8 Canopy/Suspension System

### DC Power Supply

The DC power supply consists of a 35-ampere, engine-driven alternator and a 16-ampere-hour, 12-volt, storage battery. A rectifier converts the AC output from the alternator to DC power.

The 35-amp alternator is sufficient for all types of day-night and/or IFR operation.

### Master Switch

The battery is connected to the main bus system through a two-position ON-OFF master switch located on the right console (Figure 1-3). Placing the switch in the OFF position removes battery power from the bus system but does not affect generator operation. Placing the master switch in the ON position furnishes battery power to the main bus system.

### Ammeter

An ammeter, located on the right console, indicates output of the alternator.

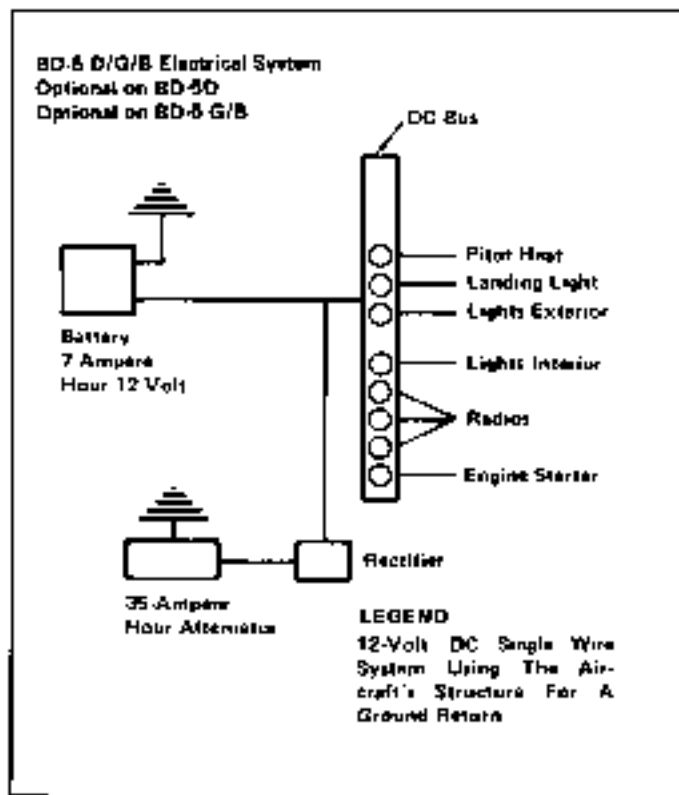

Figure 1-3 Electrical System

## EXTERIOR LIGHTING

Exterior lighting includes a combination Nav and strobe light on each wing tip and a Nav light on the tail (optional on equipment). Electrical power for operation of the exterior lighting is furnished directly from the main DC bus.

The Nav and strobe lights are operated by power from the DC electrical system and are controlled by a switch located on the left side of the instrument panel. The Nav and strobe lights are protected by a circuit breaker.

## INTERIOR LIGHTING

Interior lighting in the cockpit consists of internally lighted instruments and avionics, and side console floodlights (optional on equipment). Lighting controls are located on the upper left instrument panel.

## BAGGAGE SPACE

The space behind the pilot's seat back can be used for storage of baggage. In addition, the space between the instrument panel cover and the sides of the canopy can be used to store charts, pencils, approach plates, etc.

## SECTION 2-NORMAL PROCEDURES

---

### CONTENTS

Preparation For Flight.....	2-2	Flight Characteristics.....	2-11
Entrance To Aircraft.....	2-2	Systems Operation.....	2-11
Preflight Check.....	2-2	Descent.....	2-11
Starting Engine.....	2-6	Before Landing.....	2-11
Engine Ground Operation.....	2-6	Traffic Pattern Check.....	2-12
Before Taxiing.....	2-7	Landings.....	2-12
Taxiing.....	2-7	Go-Around.....	2-15
Engine Run-up.....	2-8	After Landing.....	2-15
Takeoff.....	2-9	Post Flight Engine Check.....	2-15
After Takeoff, Climb.....	2-10	Engine Shut-Down.....	2-17
Cruise.....	2-11	Exit From Aircraft.....	2-17



## PREPARATION FOR FLIGHT

### Flight Restrictions

Refer to Section 5 for all operating restrictions.

### Flight Planning

To determine fuel consumption, airspeed, power settings, range, etc., refer to Appendix A.

### Weight and Balance

Refer to Section 5 for weight and balance and loading information. Before each flight, check the following:

1. Takeoff and landing gross weight and cg - check within prescribed limits.
2. Fuel quantity and equipment (maps, flashlight, headset, etc.) - check adequate for intended flight.

## ENTRANCE TO AIRCRAFT

Because of the relationship between the cg and landing gear position on the BD-5 the aircraft will sit on its tail when the pilot is not on board. The aircraft may be entered from either side by placing one hand on the windshield bow (left hand for left side

entrance, right hand for right side), pushing the nose-wheel down to the ground, and stepping over the fuselage side into the seat with one foot and then the other. One hand should then be braced on each console, extended as far forward as possible, and the body lowered into a sitting position. To open the canopy from outside the aircraft, grasp the forward lower sides, one with each hand, and pull up and aft.

**NOTE:** Do not step on the canopy rails or use them as a support. Damage to the canopy rails could prevent proper canopy closure.

## PREFLIGHT CHECK

### Before Exterior Inspection

1. Required aircraft documents, placards - ON BOARD
2. Fuel valve - ON L or R
3. Trim - NEUTRAL
4. Battery and ignition switches - OFF
5. Flight controls - FREE
6. Fuel gauges - CHECK QUANTITY
7. Flaps - DOWN



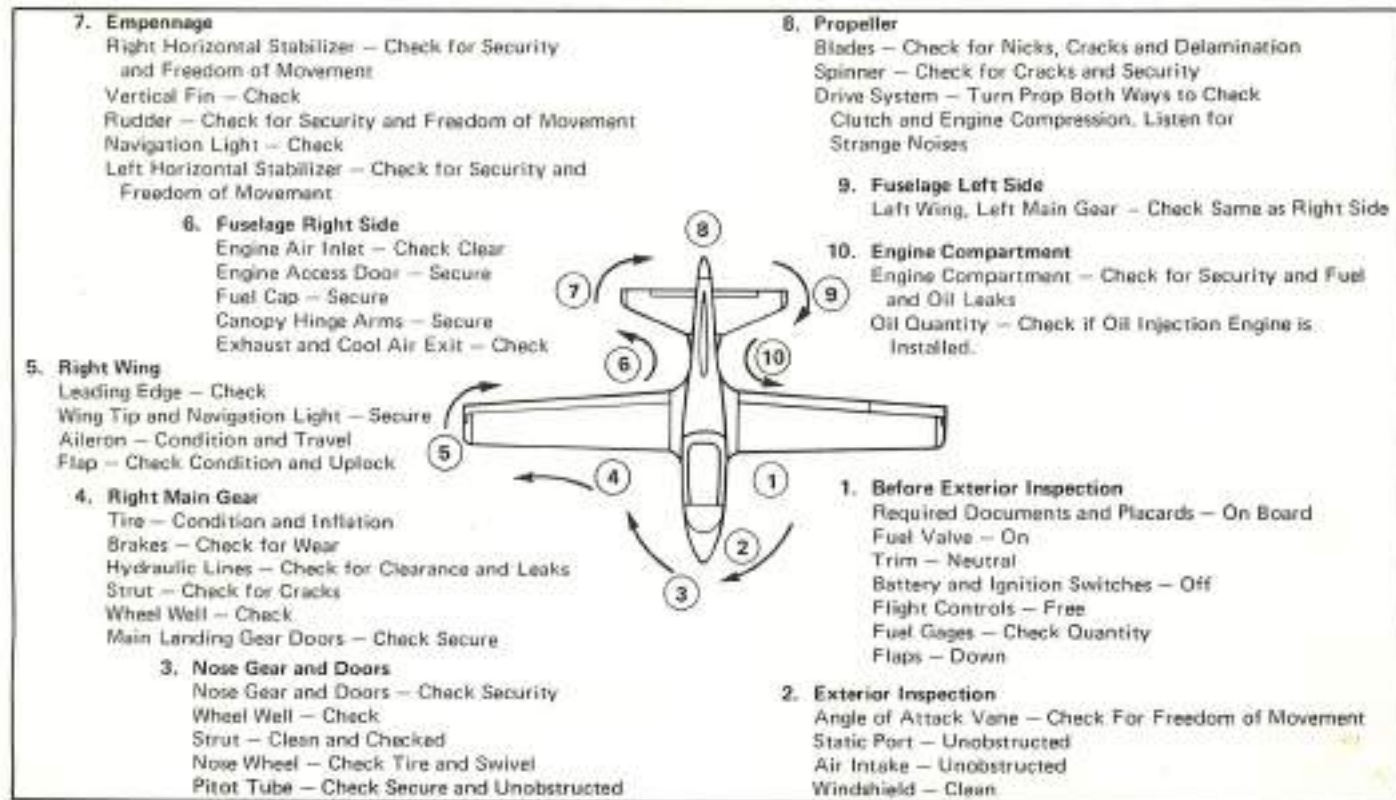

Figure 2-1 Diagram of Preflight Inspection Route

## Exterior Inspection

Starting at the left side of the cockpit, perform the following exterior inspection checks using the inspection route outlined in Figure 2-1. During this inspection, check all exterior surfaces for skin damage or other obvious defects. In addition, check beneath the aircraft for signs of fluid leakage.

### 1. Nose Section

- a. Angle-of-attach vane (if installed) – check free movement, stall warning and calibration (See Section 4)
- b. Static port   unobstructed
- c. Air intake   unobstructed
- d. Windshield   clean, free from cracks
- e. Nose landing gear doors – secure
- f. Wheel well – unobstructed
- g. Strut – clean, check damping and stiffness
- h. Nosewheel – condition, inflation, and proper swivel torque (See Appendix B)
- i. Pitot tube   straight, secure, and unobstructed

### 2. Right Main Gear

- a. Tire – condition, proper inflation
- b. Brake – check pads for wear, hydraulic line for adequate tire clearance, leaks
- c. Strut – check for cracks
- d. Wheel well – unobstructed
- e. Main landing gear doors/attachment – secure
- f. Fuel sumps – drain
- g. Cooling scoop inlet – unobstructed

### 3. Right Wing

- a. Leading edge – clean, undamaged
- b. Fuel cap – secure
- c. Wingtip and navigation light – secure
- d. Aileron – condition, full travel
- e. Flap – condition, unlock
- f. Wing retaining bolt – secure

### 4. Fuselage Right Side

- a. Engine access door – secure
- b. Canopy hinge arms – secure
- c. Exhaust/cooling air exit – unobstructed

#### 5. Empennage

- a. Right horizontal stabilizer – check security, freedom of movement, tab for anti-servo action
- b. Vertical fin – check
- c. Rudder – check freedom of movement; trim tab for security
- d. Navigation light – check mounting
- e. Left horizontal stabilizer – check security

#### 6. Propeller

- a. Blades – check for nicks, cracks, delamination
- b. Spinner – check for cracks, security
- c. Drive system – turn prop both ways to check clutch and engine compression; listen for strange noises (See Appendix B)

7. Fuselage left side, left main gear, left wing – check same as right side

8. Baggage compartment – check contents

**CAUTION:** If aerobatics are to be performed, remove all objects from the baggage compartment.

#### Interior Inspection

1. Seat back – Adjust
2. Seat belt and shoulder harness – FASTENED
3. Flight controls – Check freedom of movement and response
4. Fuel valve handle – ON L or R
5. Trim lever – 1/3 forward from aft stop
6. Throttle – CLOSED
7. Circuit breakers – IN
8. Mixture – FULL RICH
9. Clock & altimeter – SET
10. Light switches – OFF
11. Radio switches – OFF
12. Cockpit air vent – AS DESIRED
13. Ignition switches – OFF
14. Enrichment valve – OFF
15. Master switch – ON
16. Landing gear position indicators – CHECK

If flight at night is planned:

17. Navigation lights – CHECK
18. Instrument and console lights – CHECK
19. Landing light – CHECK
20. Flashlight on board and operable – CHECK

### STARTING ENGINE

Always make sure the propeller area is clear and the brakes are on before starting the engine. Leave the canopy open until the engine is running.

1. Enrichment valve – FULL ON
2. Ignition switches – ON
3. Throttle – CLOSED 2500 to 3000 rpm warmup
4. Starter – ENGAGE

As soon as engine fires, open throttle approximately one inch.

5. Throttle – 2500 to 3000 rpm for warmup
6. Enrichment valve – OFF after 5 to 7 seconds

### NOTE:

If engine does not fire after 10 seconds of continuous cranking, or if engine starts then ceases firing, release starter switch and proceed as follows:

- a. Enrichment valve – OFF
- b. Throttle – FULL OPEN
- c. Starter – ENGAGE

As engine starts, reduce throttle to 2500 to 3000 rpm. If engine does not begin firing after 15 seconds of continuous cranking, return to Step 1 and try again.

### ENGINE GROUND OPERATION

Warm up the engine at the lowest speed between 2500 and 3000 rpm at which smooth operation is obtained until the cylinder head temperature reaches 150° F. Do not use full throttle until this temperature is reached.

## BEFORE TAXIING

During engine warm-up, make the following checks.

1. Engine instruments – MONITOR
2. Radios – ON
3. Transponder – STANDBY
4. Ammeter – Indicating Charge
5. Wing Flaps – CHECK OPERATION, then UP
6. Pulse pump fuel pressure – CHECK 2.0 to 4.5 psi
7. Idle speed – CHECK, 800 to 1200 rpm
8. Radio – CHECK OPERATION

## TAXIING

1. Area – Check clear for taxi
2. Brakes – Check before building up taxi speed by applying firm toe pressure on both pedals.

The good visibility and full swivel nosewheel give excellent ground handling characteristics. The initial roll should be straight ahead, and turns should be started while the aircraft is in motion; turning from a standstill requires more power and shortens tire and

brake life. Start turns with full rudder pedal deflection in the desired direction and then add brake as required. Tighter turns will require more engine power to maintain taxi speed. Make sure the other foot does not apply opposite braking as the pedal comes back. When stopping the aircraft make sure the nosewheel is straight.

**CAUTION:** The low wings on the BD-5 will not clear standard runway/taxiway lights. Make sure adequate lateral separation is maintained.

### Downwind Taxiing

Downwind taxiing will usually require little or no throttle after the initial roll is established. To avoid overheating the engine when taxiing downwind, keep the use of power to a minimum. Rather than ride the brakes, let speed build up and apply brakes occasionally.

### Crosswind Taxiing

In taxiing crosswind, the aircraft has a significant tendency to "weathervane" (turn into the wind) due to the wind force acting on the vertical tail area and

the propeller. This tendency can be counteracted by holding the brake with pressure as necessary to maintain the desired heading. Use power as required to maintain taxi speed.

## ENGINE RUN-UP

Before taxiing onto the runway, turn as near into the wind as practical, stop the aircraft clear of the runway with the nosewheel straight, hold the brakes and perform the following checks:

1. Fuel valve handle – ON fullest tank
2. Fuel quantity – CHECK
3. Mixture control – FULL RICH
4. Throttle – FULL OPEN
5. Engine instruments – CHECK

Engine speed should be at least 4000 rpm with the 4653 propeller and 4500 rpm with the 4250 propeller. If the full-throttle rpm is less than this minimum value, a substantial power loss has occurred and the engine should be inspected by a qualified mechanic prior to flight.

6. Ignition system – Check at 3000 rpm

Alternately turn each magneto switch off, note the rpm drop, and turn back. Any rpm drop from 0 to 200 is acceptable.

**CAUTION:** Do not let CHT exceed 350° F during run-up. Perform run-up check quickly to prevent overheating.

7. Throttle – IDLE

Engine acceleration and deceleration during these checks should be smooth, without backfire, coughing, or roughness.

### Before Takeoff

1. Wing flaps – DOWN 15 degrees (first notch)
2. Trim lever – 1/3 forward
3. Mixture Control – Set for smooth engine operation
4. Engine Instruments – CHECK
5. Flight controls – Freedom of movement and proper response
6. Canopy – CLOSED and LOCKED
7. Safety belt and shoulder harness – ADJUSTED

## TAKEOFF

Takeoff in this aircraft is quite easy, and is further simplified by good visibility and low speed controllability. Even though this is true, any takeoff can be improved by proper technique and careful planning. Plan your takeoff according to the following variables affecting takeoff performance: field elevation, gross weight, wind velocity, temperature, and type of runway. A normal takeoff as outlined herein will give the takeoff performance shown in Appendix A.

### Normal Takeoff

Release the brakes and roll into takeoff position, aligning the nosewheel with the runway, and advance the throttle smoothly to full OPEN. During the initial part of the takeoff roll, maintain directional control with brakes, until the rudder becomes effective at about 35 mph IAS. At 55 to 60 mph IAS apply back pressure to the stick and raise the nosewheel off the runway, high enough that the top of the instrument panel appears to be on the horizon. When the aircraft is ready, it will fly itself off the ground at 70 to 75 mph IAS. (Confirm EGT within limits.)

### NOTE:

For procedure to be followed in the event of engine failure during takeoff, refer to Section 3.

### Minimum Run Takeoff

For a minimum run take off, line up with the runway, hold the brakes and put down full flaps. Advance the throttle to full OPEN and release the brakes. Do not assume a nose-high attitude until reaching approximately 60 mph IAS. Apply aft stick rapidly but smoothly to assume a nose-high (takeoff) attitude so that lift-off will occur as soon as minimum flying speed is reached (approximately 65 mph IAS). When clear of the runway, retract the gear while lowering the nose slightly to accelerate to 80 mph, and then retract the flaps to 1/2. Raise the remaining flaps at 90 mph IAS and continue with the normal takeoff and climb procedure.

### Obstacle Clearance Takeoff

Use the same procedure for a minimum run takeoff, except use only 1/2 flaps and do not assume the nose high takeoff attitude until reaching 70 mph IAS. Clear the runway, retract the gear and wheel 80 mph



IAS has been attained, hold this airspeed until the obstacle is cleared. Accelerate to 90 mph, raise the flaps, and continue with a normal climb.

#### **Crosswind Takeoff**

When making a crosswind takeoff, directional control may be somewhat more difficult; therefore, use smooth power application and attempt to correct for the crosswind by using a combination of upwind aileron and downwind rudder. Use of the downwind brake will be necessary until a speed for adequate rudder control is reached. Use of brakes on the takeoff roll will lengthen the distance considerably and in hard crosswinds the takeoff roll can be increased as much as 35 percent (see Appendix A). Hold the nosewheel on the ground longer than in a normal takeoff, using aileron as required to hold the wings level. As flying speed is reached, (approximately 70 mph IAS) make the pull-off definite to avoid side-skipping as the aircraft starts to lift off. When definitely airborne, correct for drift by making a coordinated turn into the wind.

#### **Night Takeoff**

Night takeoff procedure is similar to normal daytime takeoff; however, you should be thoroughly familiar with the location of all switches and controls in the cockpit. Align the aircraft with the runway carefully before starting the takeoff, preferably using a sighting point to aid in directional control during the run. After becoming airborne, maintain takeoff attitude longer than in a normal daytime takeoff before retracting the landing gear.

#### **AFTER TAKEOFF – CLIMB**

1. Landing gear – UP
2. Flaps – UP
3. Throttle – FULL FORWARD

Climb is normally made with full throttle. You will note that engine speed drops off as altitude increases. Refer to the climb chart in the Performance Data, Appendix A, for fuel consumption, recommended climb speeds, and rates of climb for varying altitudes and gross weights.



## **CRUISE**

After the aircraft has reached cruising altitude, trim for level flight and adjust power as necessary to attain cruising airspeed. Refer to Appendix A for information on cruise performance.

## **FLIGHT CHARACTERISTICS**

Refer to Section 6.

## **SYSTEMS OPERATION**

Refer to Section 7.

## **DESCENT**

1. Mixture control - FULL RICH
2. Throttle - 5000 rpm

Descent from cruising altitude is best accomplished by letting down in a fast, low power cruise. During prolonged glides or gliding turns, the engine should be cleared at least every 180 degrees of turn, or as often as necessary.

Clearing the engine has a threefold purpose: (1) to keep the cylinder head temperature above 200°F, (2) to prevent the engine from becoming "loaded up" due to an excessively rich idle mixture, and (3) to give an early warning of carburetor icing. The throttle should be applied smoothly and evenly during this clearing process to prevent killing the engine in the event an overrich mixture condition is present.

## **BEFORE LANDING**

1. Radio - Check proper frequency
2. Mixture control - Set for smooth engine operation
3. Altimeter - SET

### **Entry to Pattern**

1. Airspeed - 110 mph
2. Landing gear - DOWN
3. Landing gear position indicators - CHECK

### **Downwind**

1. Airspeed - 110 mph
2. Shoulder harness - FASTENED
3. Flaps - DOWN 1/2 at key position

**Base**

1. Airspeed – 100 mph
2. Flaps – AS REQUIRED
3. Engine – CLEAR by adding power temporarily

**Final**

1. Airspeed – 90 mph
2. Flaps – FULL DOWN
3. Power – AS REQUIRED
4. Brakes – CHECK by depressing brake pedals and noting resistance.

**TRAFFIC PATTERN CHECK**

Typical landing pattern and traffic pattern checks are detailed in Figure 2-2. Although pattern configurations may vary locally, the checks shown apply to all landings.

**LANDINGS****Normal Landings**

A normal landing in this aircraft is made with full flaps, using either a power-on or power-off approach. In using flaps, lowering to half flaps at key position on downwind will help to establish a suitable glide angle for approach and the additional flap can then be applied on the approach as determined by wind velocity. Speed should be decreased throughout the pattern to approximately 100 mph IAS for base leg, 90 mph for final, and to approximately 80 mph as you begin the flare. Start flaring just over the end of the runway at about 10 feet and if a power-on approach was used, start removing power simultaneous with the flare. Level off at about 1 foot, and as airspeed decreases, continue a smooth, continuous increase of back pressure on the stick and touch main wheels first, holding the nosewheel off with back pressure and maintain directional control with the rudder. Lower the nosewheel while you still have ample elevator control. Let speed dissipate as much as practical before using brakes.

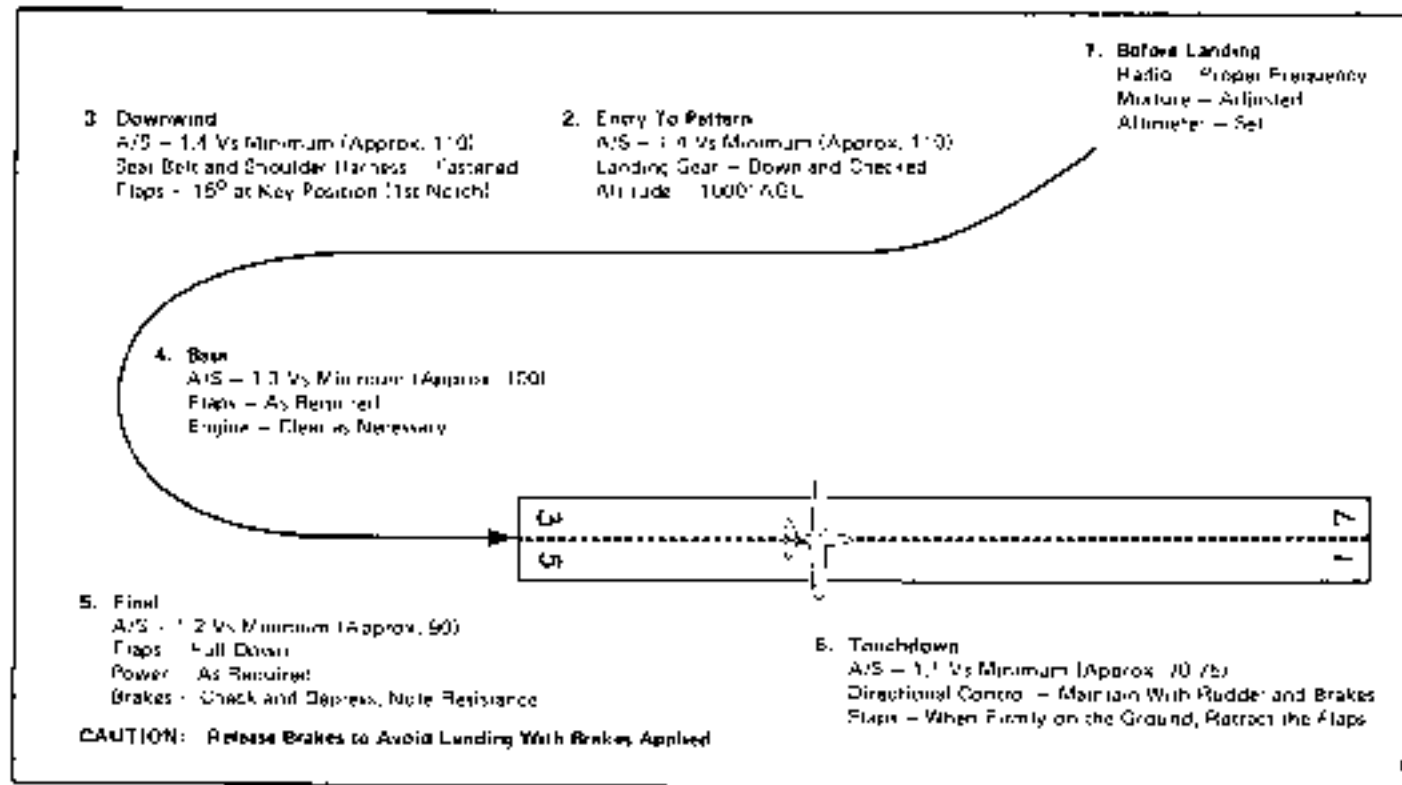

Figure 2-2 Diagram of Normal Landing Pattern

### Minimum-Run Landing

A minimum-run landing involves touching down at the lowest speed practical to cut down the landing roll. Since this is a maximum-performance maneuver and the aircraft is just above stalling speed, care must be exercised in handling of the flight controls. To execute a minimum-run landing, lower full flaps after turn onto final approach and slow the aircraft to 75 mph IAS, controlling the rate of descent with power. Plan to land as short as possible and start flare-out just over the fence, using very gradual stick pressure. Immediately at touchdown, cut the throttle, lower the nosewheel smoothly to the runway, retract the flaps, and apply brakes.

**CAUTION:** Don't use brakes before letting the nosewheel down; doing so can cause the aircraft to pitch, dropping the nosewheel hard.

### Crosswind Landing

Landing in a crosswind presents no special problems except the elimination of drift correction, at the proper moment, to avoid touching down in a skid. Correction for drift may be accomplished by three methods: crabbing, carrying the upwind wing low (a slip), or a combination of both. Crabbing is most successful for the traffic pattern phase while a combination is most successful for landing. Generally, full flaps should be used, depending on the velocity and angle of the wind since stall characteristics, in a slip, are better with full flaps. Approach the runway with crab, but eliminate most of the crab on nearing the runway by replacing the crab with an upwind, wing-low attitude. Touch down easily onto the low main wheel while flying airspeed remains, and allow the aircraft to settle smoothly onto the opposite gear. Lower the nosewheel smoothly to the runway to preserve directional control. If an excessive amount of crab should remain just prior to touchdown, attempt to eliminate it at point of touchdown by use of rudder. If excessive skidding across the runway appears imminent, make a coordinated turn to realign with the runway and drop the upwind wing to correct for tendency to drift.

### Night Landing

Night landing technique is similar to normal daytime landing, except that judgment of distance may be somewhat affected in semi-darkness. Don't use landing lights until at a low enough altitude for them to be of use and avoid using them in thick haze, smoke or fog, as reflected light from the particles in the air will reduce, instead of enhance, visibility.

### GO-AROUND

Make the decision to go around as early as possible in the landing approach to provide a safe margin of air-speed and altitude. The go-around procedure is a normal maneuver and does not become an emergency procedure unless it is started too late. Accuracy of judgment and early recognition of the need to go around are important, these are developed by practice. Go-around procedure is shown in Figure 2-3.

### AFTER LANDING

Wing flaps UP

When landing is made on an unprepared runway, retract the flaps as soon as the nosewheel touches the runway, if practical, to reduce the possibility of damage to the flaps from mud or gravel thrown up by the wheels. After the landing roll, clear the runway immediately. Also use caution in taxiing over uneven or soft terrain, avoiding severe bumps or hard braking, and use a minimum of throttle in loose gravel or sand.

### POST-FLIGHT ENGINE CHECK

Park the aircraft with the nosewheel straight, and make the following checks:

1. Instruments – CHECK
2. Engine idle speed – CHECK

With the throttle in fully CLOSED position, the engine should idle at 800 to 1200 rpm.

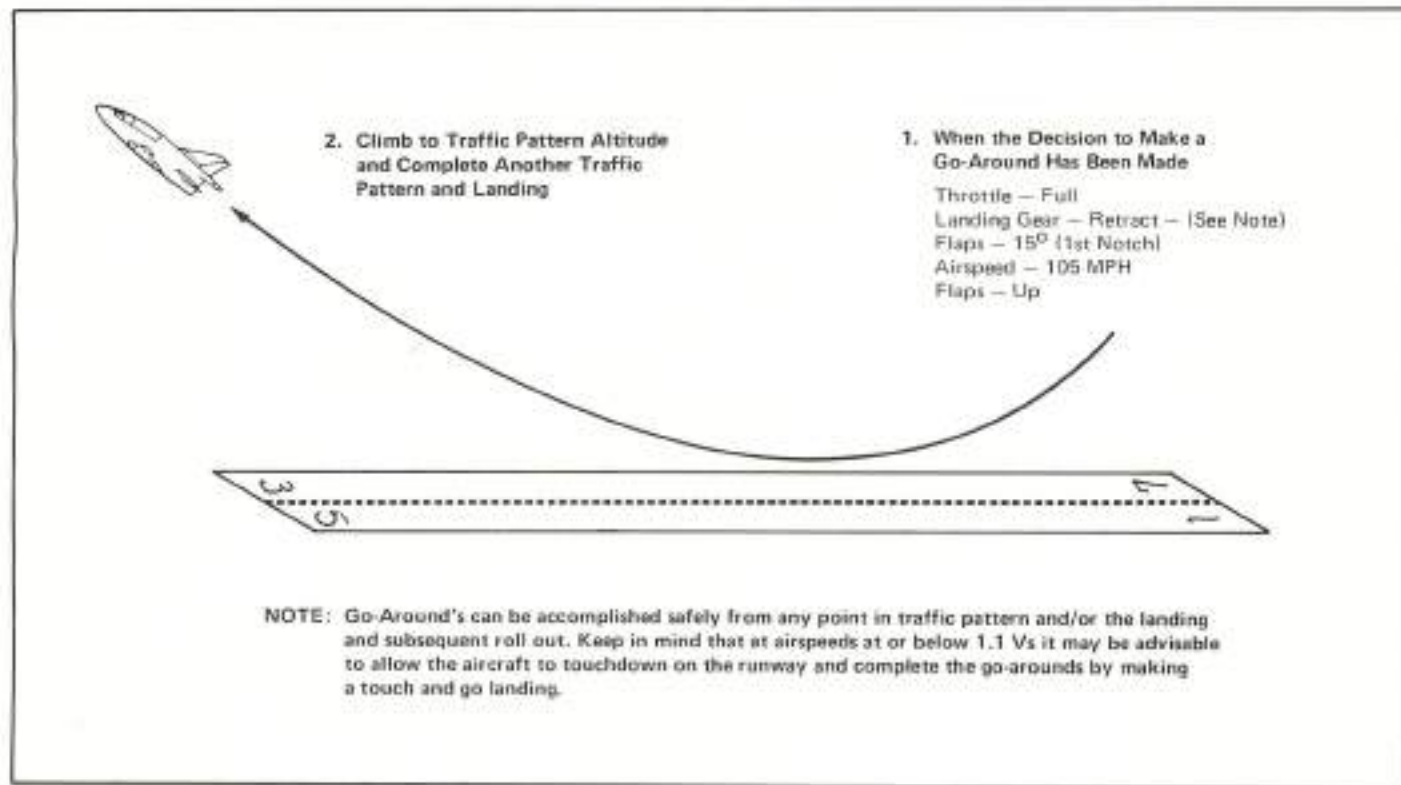

Figure 2-3 Diagram of Go-Around

3. Ignition switch – CHECK (grounded).

Set throttle at 2000 rpm and quickly turn ignition switches to OFF and back to BOTH and note whether engine momentarily stops firing. If engine does not stop firing completely, one or more magneto leads are not grounding properly and the engine should be shut down immediately. As soon as the engine stops, warn personnel to keep clear of the propeller.

4. Ignition system – CHECK at 3000 rpm, 200 rpm maximum drop.

**NOTE:** A marginal rpm drop may be due to fouled plugs resulting from prolonged operation at idle rpm. Advance the throttle to full power for a few seconds in an attempt to clear engine and repeat test.

5. Engine power – CHECK – Advance the throttle with a smooth motion to full OPEN (full power) and check to see that the desired rpm is obtained. Acceleration and deceleration during this check should be smooth without backfire, coughing, or roughness.

**NOTE:** Run engine up to full power only on paved areas to avoid damage from loose gravel picked up by the propeller.

#### ENGINE SHUT-DOWN

1. Throttle – 2000 rpm
  2. Radios – OFF
  3. Ignition switches – OFF
  4. Throttle OPEN
- After engine has stopped:
5. Throttle CLOSED
  6. Electrical switches – OFF

#### EXIT FROM AIRCRAFT

To get out of the BD-5, the pilot should release his safety belt, put one hand on each side console, lift himself up and to the rear until his feet are clear of the instrument panel, and then stand up in the seat. To prevent the tail from falling down, the pilot should put one hand on the front of the windshield and hold the nose down as he steps out. He can then let the tail down gently. For overnight or long term tie-down, the nosewheel can be tied to a tie-down to hold the aircraft in a level attitude.

Lined writing area with 20 horizontal lines.

NOTES:

<https://aircraftmanual.jimdofree.com/>



## SECTION 3—EMERGENCY PROCEDURES

---

### CONTENTS

Introduction . . . . .	3-1
Engine Failure . . . . .	3-2
Maximum Glide . . . . .	3-5
Simulated Forced Landing . . . . .	3-5
Forced Landing . . . . .	3-5
Smoke and Fume Elimination . . . . .	3-8
Bail-Out . . . . .	3-9
Landing Emergencies . . . . .	3-10
Emergency Entrance . . . . .	3-12
Ditching . . . . .	3-12

### INTRODUCTION

The procedures described in this section are presented to give the pilot a comprehensive understanding of most of the emergencies he could encounter while flying a BD-5.

All of these emergencies are highly unlikely and, in general, apply to all aircraft, not just the BD-5.

The recommended procedures given herein for coping with emergency situations are the best techniques presently available, based on flight test results and operational experience. Multiple emergencies, weather, unusual conditions, etc., may require deviation from these procedures.

## ENGINE FAILURE

Engine failure in the BD-5 is characterized by a loss of rpm and thrust. The propeller and upper drive system will continue to windmill because of the over-running clutch in the system. Although the pilot cannot see the propeller, he can hear and feel the upper drive system rotation, the sound of which will change with airspeed. Engine failure is usually preceded by symptoms which will enable you to take preventative action if you are alert to engine characteristics at all times. Instant and complete engine failure most often occurs due to fuel flow or ignition failure. Failure due to carelessness or improper operating techniques is not rare and should be guarded against by constant attention to such things as cylinder head temperature, exhaust gas temperature, rpm, sound of the engine, and by observing the operating limitations discussed in Section 5. If engine condition appears to be abnormal, land as soon as possible.

### Engine Failure During Takeoff (Prior To Becoming Airborne)

1. Throttle – CLOSED
2. Flaps – UP
3. Brakes – APPLY
4. Ignition switches – OFF
5. Master switch – OFF
6. Canopy – OPEN

As soon as the aircraft stops, get clear at once.

### Engine Failure During Takeoff (After Becoming Airborne)

1. Glide – Establish at 80 mph IAS
2. Ignition switches – OFF
3. Master switch – OFF

Complete landing, and as soon as the aircraft is stopped, get clear at once.

**NOTE:** When engine failure from an unknown cause occurs, there is always the possibility of a resultant engine fire. For this reason, any items of the engine shutdown procedure which cannot be completed before landing, should be completed as soon as practical on the ground.

#### **Engine Failure After Takeoff**

If the engine fails after the aircraft has left the ground and there is not sufficient prepared landing area remaining in front of the aircraft, lower the nose to avoid a stall and prepare to land straight ahead.

**WARNING:** Under no circumstances should a turn be attempted at low altitude with a dead engine, except slight deviations to avoid hitting an obstacle. A controlled crash landing straight ahead is preferable to a stall and crash, out of a turn.

1. Landing gear – DOWN

**WARNING:** Statistical studies indicate that forced landings with a BD-5 aircraft in any type of terrain are less likely to result in injury or fatality if the landing gear is in down position.

2. Flaps – FULL DOWN
3. Ignition switches OFF
4. Master switch OFF

Make a normal flare to a full stall landing.

#### **Engine Failure During Flight**

In the event of engine failure during flight, maintain 90 mph IAS for best glide distance and prepare for a forced landing. Attempt to restart the engine if no damage is suspected and if altitude permits. If the engine fails to start, complete the shutdown procedures and make a forced landing.

Immediately upon encountering partial power failure or noting any condition which would point to imminent engine failure, such as loss of power, high CHT, rough running engine, etc., land at the nearest airport.

### Engine Restart During Flight

1. Throttle – IDLE
2. Mixture – RICH
3. Ignition switches – BOTH ON
4. Enrichment valve – AS REQUIRED

Enrichment will be required if CHT has dropped below 200°F, otherwise leave the valve FULL OFF.

5. Starter – ENGAGE

### If Engine Fails To Restart

6. Throttle – CLOSED
7. Ignition switches – BOTH OFF
8. Master switch – OFF
9. Seat belt and shoulder harness – FASTENED

### Fuel Pressure Drop – Engine Operating Normally ON THE GROUND

If fuel pressure should drop below operating minimum while the engine is operating normally on the ground, shut the engine down and have a fire guard stand by. Do not take off until the cause has been determined and corrected.

### IN FLIGHT

A drop in fuel pressure reading with continued normal engine operation in flight may be the result of one or more of the followings:

1. Obstruction in pressure line
2. Instrument failure
3. Fuel line leak
4. Failure of one pulse pump (indicated by half normal fuel pressure).

If the low pressure reading is the result of a clogged pressure line or faulty instrument, normal engine operation can be continued. If a fuel leak is found, land at once. If the cause of the low fuel pressure cannot be determined, you should land as soon as possible. If the decision is made to continue flight to your destination, a constant watch should be kept for an engine fire, by making S-turns every few minutes to watch for a smoke trail behind the aircraft. Because of the danger of a backfire, never retard the throttle at any time if a fuel leak is detected. Wait until the aircraft is in a position to land on the runway with the power off, and then shut the engine down with the fuel valve. Do not retard the throttle until the engine stops turning.

## MAXIMUM GLIDE

The greatest gliding distance can be attained by leaving the landing gear and flaps up and maintaining 125 mph IAS. At design gross weight, this will give a glide ratio of approximately 15 to 1 (Figure 3-1) with a no-wind condition. Once over a chosen landing area, the glide angle can be steepened by lowering the flaps and the landing gear, as required. The best technique is to lower to half flaps and place the landing gear at key position. Then, if it is necessary to shallow the glide angle, the landing gear can be raised and lowered in the same manner as spoilers on a glider, since the cycle time is much less than one second. If a much steeper glide is required, the flaps can be put full down. Make sure that the final configuration before touchdown is gear down and full flaps.

## SIMULATED FORCED LANDING

1. Throttle – CLOSED
2. Glide – Establish at 90 mph IAS
3. Fuel valve – ON
4. Fuel pressure – CHECK
5. Mixture – Set for smooth engine operation

6. Wing flaps – UP
7. Landing gear – UP
8. Shoulder harness -- FASTENED
9. Trim – AS REQUIRED

## FORCED LANDING

1. Throttle – CLOSED
2. Glide – Establish at 90 mph IAS
3. Fuel selector valve – OFF
4. Ignition switches – OFF
5. Master switch – OFF
6. Shoulder harness – FASTENED
7. Landing gear – DOWN when landing is assured
8. Flaps – AS REQUIRED

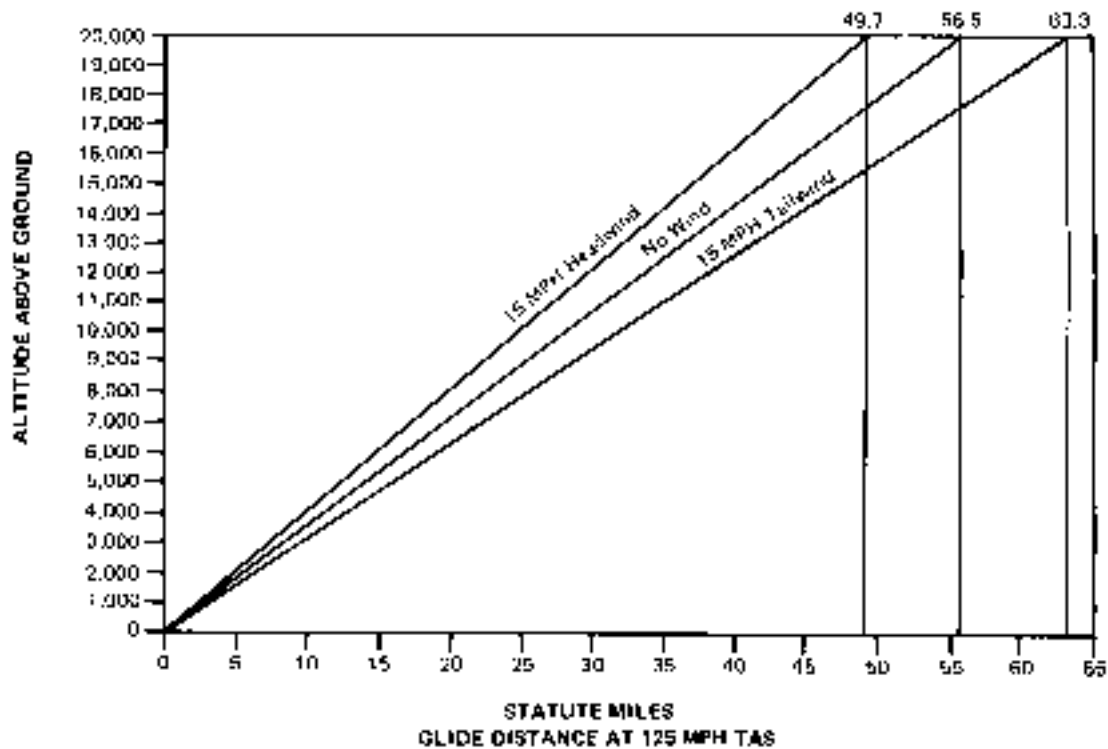

Figure 3-1 Glide Distance Chart

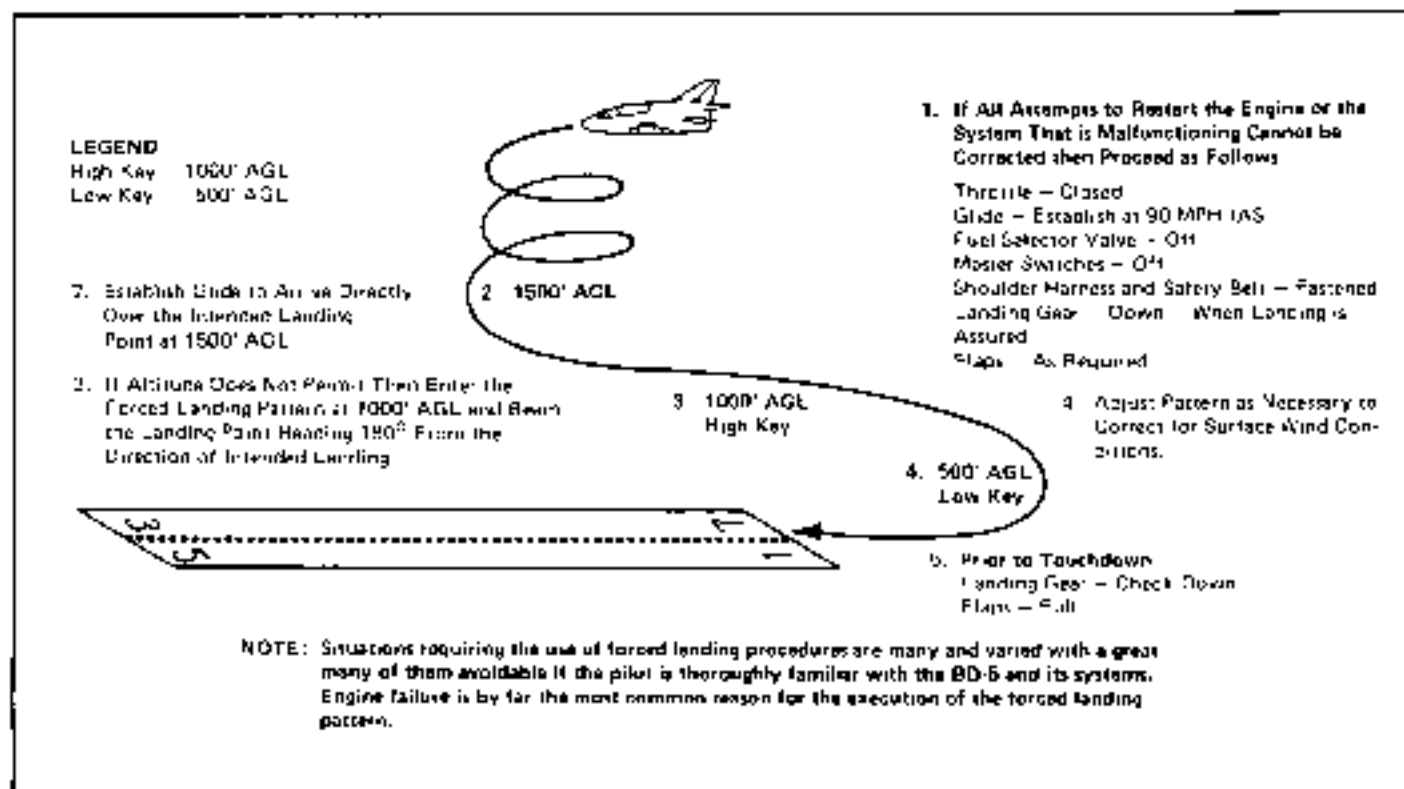

Figure 3-2 Diagram of Forced Landing Pattern

**Engine Fire During Flight**

The only indications of an engine compartment fire during flight are a slight rise in CHT and a smoke trail behind the aircraft. At the first sign of any unusual engine operation, make several steep banked S-turns to check for a smoke trail; if one exists, proceed as follows:

1. Fuel valve – OFF

After engine quits:

2. Ignition switches – OFF

3. Master switch – OFF

4. Throttle – CLOSED

5. Execute forced landing

**Fuselage/Electrical Fire In Flight**

1. Canopy – CLOSED

2. Cockpit air vent – CLOSED

Shutting the air vent and reducing airspeed will minimize the draft through the cockpit:

3. Master switch – OFF

4. All electrical equipment – OFF

5. All circuit breakers – PULLED

All electrical circuits are protected by circuit breakers which will isolate a short circuit and tend to prevent a fire. Should an electrical fire start, however, try to locate the faulty circuit by process of elimination. Turn the master switch ON to determine if that circuit is faulty. If it is all right, turn on the remaining switches and push in the circuit breakers one at a time to locate and isolate the shorted circuit. If the short circuit is not located, use only that electrical equipment which is absolutely necessary for safe flight.

**Wing Fire**

There is little that can be done to control a wing fire, except to try to blow it out by slipping the aircraft away from the fire. If the fire cannot be extinguished in this manner, either land immediately or bail out.



## **SMOKE AND FUME ELIMINATION**

1. Cockpit vent – FULL OPEN
2. Heater valve – CLOSED

**NOTE:** The heater valve should be left closed since the possibility of the duct system being damaged by a fire may direct additional smoke to the cockpit.

If conditions continue to worsen:

3. Airspeed – Less than 90 mph
4. Canopy – OPEN
5. Land as soon as possible, or bail out.

## **BAIL-OUT**

Reduce speed as much as possible, using full flaps to provide a more tail-high attitude.

1. Wing flaps – FULL DOWN
2. Canopy – OPEN
3. Seat belt and shoulder harness – RELEASE

Make sure safety belt and shoulder harness will not foul on clothing or parachute on exit.

4. Headset – REMOVE and toss overboard

Make the decision to abandon the aircraft while there is plenty of altitude and (when possible) the aircraft is under control. Head the aircraft toward an uninhabited area. To leave the cockpit while airborne, lean forward as much as possible, put one hand on each side console and slide your body up and aft. You should wind up with both feet in the seat, holding on to the canopy rails, with your head as low as possible to minimize wind blast. Put one foot on the side console opposite the side you plan to jump from, and dive out onto the wing, aiming at the flap. As you leave the aircraft, it will pitch up and roll slightly in the direction you jumped, but if the aircraft was trimmed for level flight, you will clear the tail with room to spare.

**WARNING:** In a spin, bail out toward the outside of the spin to minimize the possibility of being struck by the aircraft.

## LANDING EMERGENCIES

### Gear-Up Landing

The best surface for a gear-up landing is smooth grass or sod. A hard-surfaced runway is preferable to rough ground, however, since ruts or chunks of sod will do more damage to the aircraft.

1. Wing flaps – FULL DOWN
2. Shoulder harness – FASTENED

Make a normal approach using power and flaps. Just before touchdown, assume a slightly nose-high attitude, but not fully stalled. Touch down in this attitude and as soon as the aircraft has stopped, get clear at once.

When committed to landing:

3. Throttle CLOSED
4. Fuel valve OFF

After engine quits

5. Ignition switches OFF
6. Master switch OFF

### Off-Runway Landings

Landing procedure for unprepared surfaces is similar to normal landings on paved runways, except that if the surface is very rough, touch down as slowly and as smoothly as possible to minimize shock loads on the landing gear; hold the nosewheel off as long as possible. On gravel runways avoid using full flaps, as rocks thrown up by the wheels will damage the flaps. On soft ground, use brakes with caution to prevent digging in the nosewheel.

### Landing With Flat Tire

A flat tire on a main wheel will act as a brake when on the ground, tending to turn the aircraft into the flat. Touch down well over to the opposite side of the runway to allow room for a swerve and hold directional control with opposite brake. A flat nosewheel tire will reduce nosewheel stability and hard applications of brake should be avoided. After landing with a flat tire, park the aircraft clear of the runway and shut down the engine; do not attempt to taxi in with a flat tire.

### Landing With Brake Failure

If brake failure is suspected, land the aircraft as short as possible using full flaps and holding up the nosewheel to shorten the landing roll. Lose as much speed as possible on the landing roll, then clear the runway, shut down the engine and stop, turning onto rough ground if necessary.

**CAUTION:** Do not taxi without brakes. Call the tower operator and request assistance.

### Landing With One Main Gear Retracted

Because of the design of the gear actuation system (all gear is extended and retracted with a single handle), failure of one gear to extend is highly unlikely. Should a break in the linkage occur, the affected gear will remain in the up and locked position, unless it was not over center at the time of the breakage. If the gear was not locked up, it could possibly be locked down by maneuvering the airplane. If one gear position indicator still fails to indicate gear down and locked, have the gear position checked visually by another pilot or by a ground

observer. If it is verified that one gear is not fully extended, attempt to retract all gear and make a gear-up landing. If all gear cannot be retracted, make a normal approach with full flaps and power on to reduce landing speed to a minimum, carrying the wing slightly lower on the side with the down and locked gear. Touch down smoothly on the down and locked main gear, holding the opposite wing up with aileron as long as possible after the nosewheel touches down. As soon as the down and locked gear touches down, proceed as follows:

1. Throttle CLOSED
2. Ignition switches OFF
3. Master switch — OFF

As the wing tip strikes the ground, apply opposite brake hard. Get clear of the aircraft as soon as it stops.

### Landing With Nosewheel Retracted

Should the nose gear fail to extend, make a normal approach and landing. After the main wheels touch down, raise the flaps and hold the nose up in a level attitude as long as possible with full aft stick and full nose-down trim. Before the nose settles onto the runway:

1. Throttle – CLOSED
2. Ignition switches – OFF
3. Master switch – OFF

### EMERGENCY ENTRANCE

The canopy may be opened from the outside in an emergency by breaking the upper forward part of the canopy and releasing the lock.

### DITCHING

If a flight is planned which will take the aircraft out of gliding distance from land, both a parachute and life vest should be worn. Since all survival equipment carried will be personal equipment, there is usually no reason to ditch the aircraft; a bail-out is preferable. If, for some reason, ditching is necessary, declare an emergency and plan to touch down before

all fuel is exhausted, so power will be available for a controlled landing:

1. Landing gear – CHECK-UP
2. Canopy – OPEN
3. Master switch – OFF
4. Seat belt and shoulder harness – FASTENED
5. Life vest – CHECK
6. Wing flaps – FULL DOWN

Make a normal approach with power, if possible, and flare to a normal landing attitude. Unless the wind is high, or the water is rough, plan to approach heading parallel to any uniform swell pattern and try to touch down along a wave crest just after the crest passes. If the wind is as high as 25 knots, or the surface is irregular, the best procedure is to approach into the wind and touch down on the falling side of the wave. Just before touchdown:

7. Ignition switches – OFF

Get clear of the aircraft as soon as it comes to rest, since it may stay afloat only a few seconds, depending on fuel quantity and damage. Stay near the site of the ditching, if possible, to aid search personnel in rescue efforts.

**SECTION 4-AUXILIARY EQUIPMENT** \_\_\_\_\_

### Heating System

The final BD-5 heating system is currently being tested, details will be forwarded to all handbook owners as soon as the system is finalized. The system is very similar to the systems used on most general aviation aircraft. A heat exchanger around the engine exhaust muffler with outside ram air is used to provide the force to move it to the cockpit for defrosting or heating as required.

### Ventilation System

Flush Scoop Is Located  
Forward of the Windshield

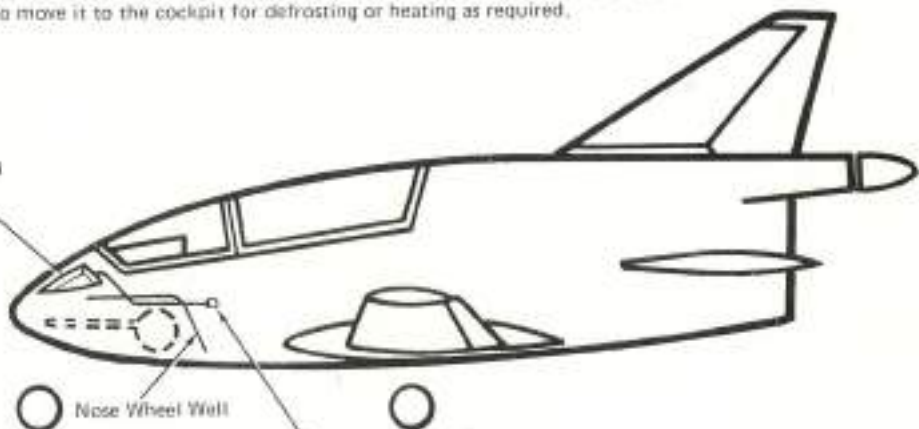

Control is a push-pull knob attached to a sliding gate that opens or closes the opening in the flush mounted scoop. Control is mounted on the nose gear well just forward of the flap handle.

Figure 4-1 Diagram of Heating and Ventilation System

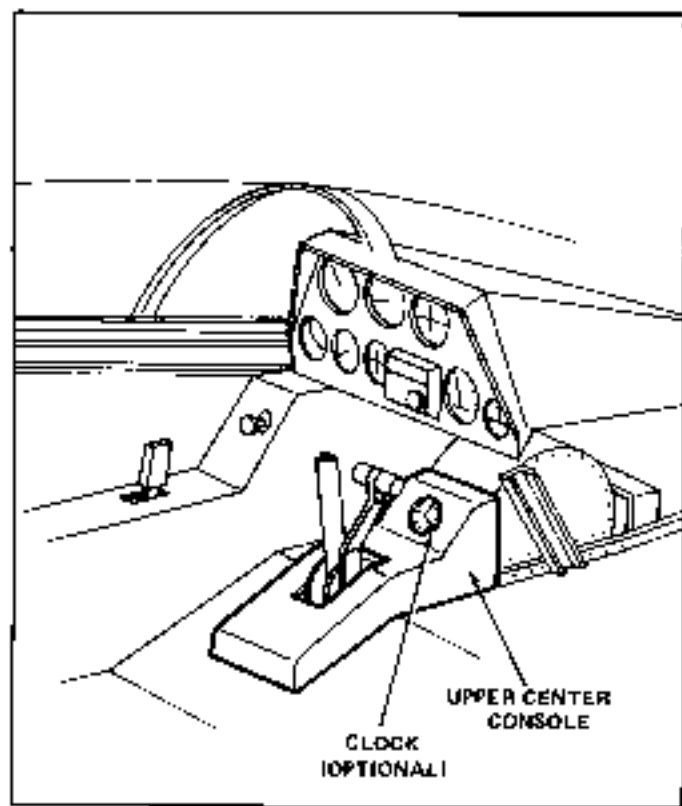

Figure 4-2 Diagram of Upper Center Console

Lined writing area with 20 horizontal lines.

NOTES:

<https://aircraftmanual.jimdofree.com/>



## SECTION 5—OPERATING LIMITATIONS\_\_\_\_\_

CONTENTS	
General Limitations.....	5-1
Crew Requirements.....	5-1
Engine Limitations.....	5-2
Airspeed Limitations.....	5-2
Prohibited Maneuvers.....	5-2
Acceleration Limits.....	5-5
Operating Flight Strength.....	5-5
Center-of-Gravity Limitations.....	5-6
Loading Limitations.....	5-6
Operating Limitations.....	5-11

### GENERAL LIMITATIONS

Most operating limitations are covered by the instrument markings and placards shown in Figures 5-1 and 5-2. Other limitations and conditions are discussed in the following paragraphs.

### CREW REQUIREMENTS

The BD-5B/D/G aircraft are designed for normal operations with pilots weighing from 160 pounds to 200 pounds and, for this weight range, will require no ballast. Lighter pilots will require the addition of weight to the nose of the aircraft in accordance with the loading limits shown in the Figure 5-3. Heavier pilots may also operate the BD-5, but with limited fuel capacity.

## ENGINE LIMITATIONS

Normal operating limitations for the Xenosah engine are illustrated in Figure 5-1. The engine should not be operated below 4000 rpm for prolonged periods in flight to avoid rough operation and spark plug fouling. Maximum operating speed is 6250 rpm. When the engine is run beyond red line (6250 rpm), damage to the engine can result and the manufacturer's warranty will be void. Continuous inverted flight or flight with zero or negative g for more than five seconds will cause fuel starvation and subsequent engine stoppage. See Section 7 for engine operating techniques.

## AIRSPEED LIMITATIONS

Airspeed limitations are placarded in each aircraft as shown in Figure 5-1.

## PROHIBITED MANEUVERS

Aerobatic maneuvers, including spins and snap maneuvers are permitted; however, the aircraft should not be subjected to negative g forces for periods in excess of five seconds. Prolonged inverted flight in excess of this period causes fuel starvation as there is no means of ensuring a continuous flow of fuel in this attitude. Aerobatic maneuvers approved for this aircraft are listed on the cockpit operating limitations placard and are discussed in Section 6.

**CAUTION:** All aerobatic maneuvers should be practiced at an altitude sufficient to permit a complete recovery at 3000 feet above the terrain.

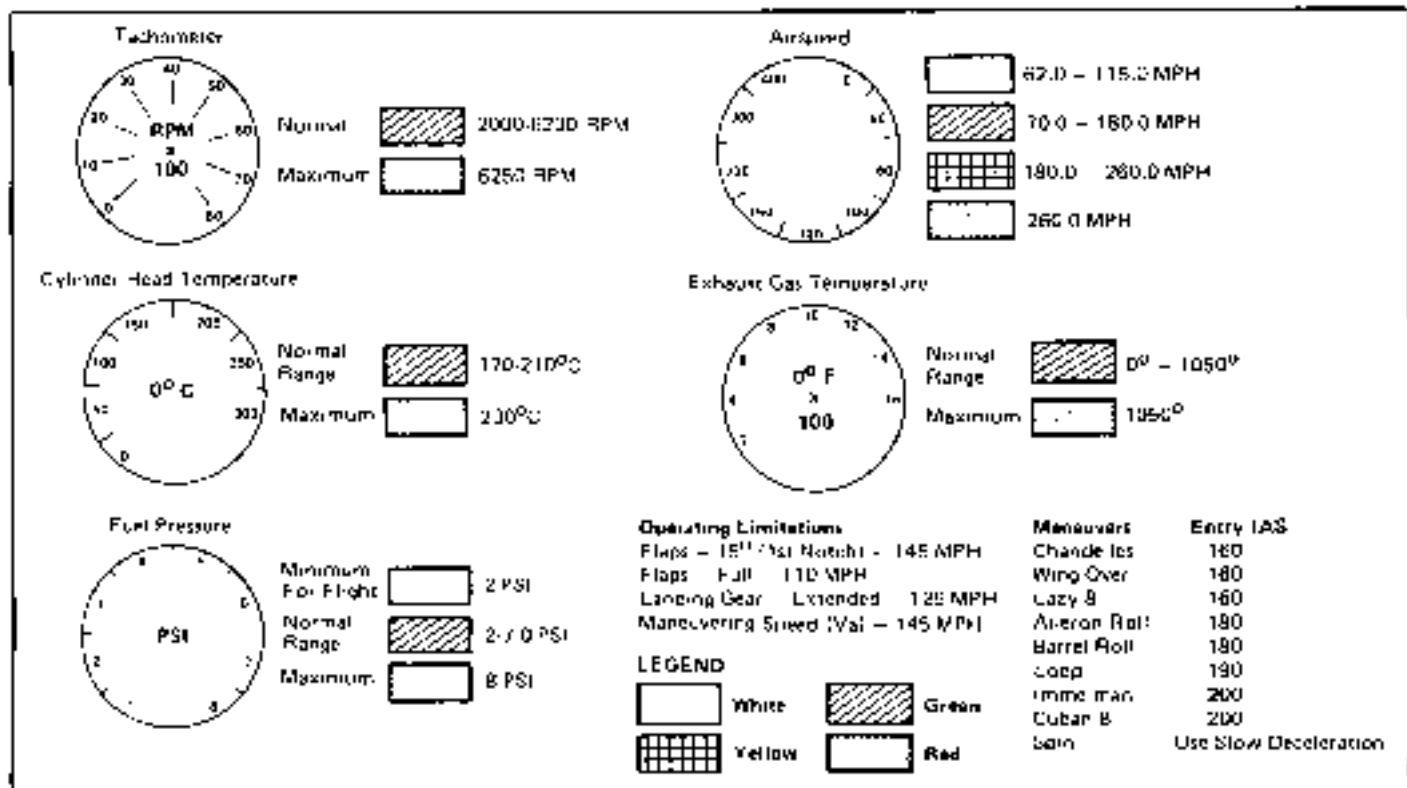

Figure 5-1 Instruments Markings and Operating Limitations Placard

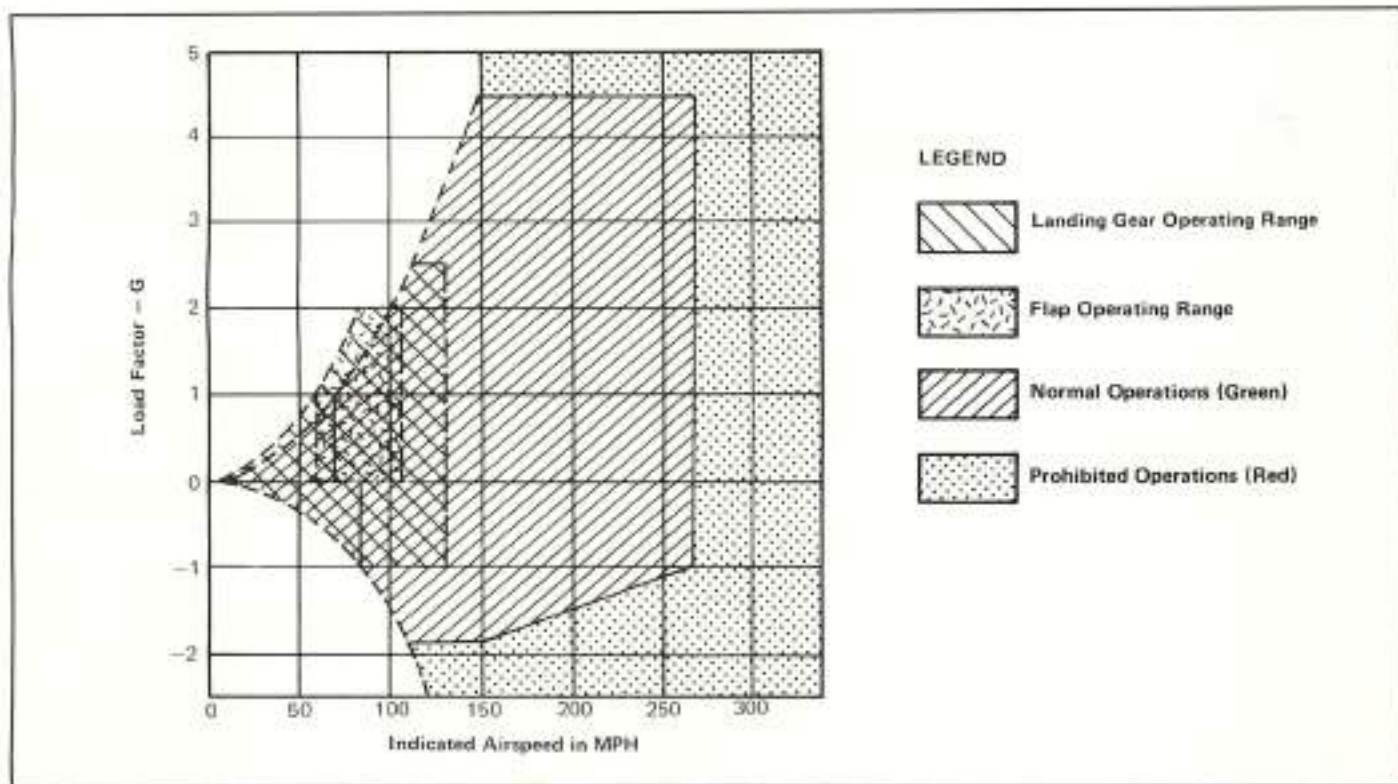

Figure 5-2 VN Diagram

## ACCELERATION LIMITS

Limitations on the acceleration to which the aircraft may be subjected in maneuvering is determined by the structural load limitations on the wings, expressed as a factor of the force exerted by gravity (G). This aircraft is limited to a maximum positive factor of 4.4 g's clean, and 2 g's with flaps down. The limit negative load factor is 1.76 g's. These limitations are based on the design gross weight of 710 pounds BD-5B or 850 lbs. BD-5D/G, and apply only to straight pull-outs. Rolling pull-outs impose considerably more stress on the aircraft; therefore, they should be less severe. The maximum allowable g-limit for a rolling pull-out is two-thirds the maximum g-limit for straight pull-outs.

## OPERATING FLIGHT STRENGTH

Load limits on the aircraft, based on structural limitations, are shown in Figure 5-2.

The normal operating conditions are represented by the green shaded area and prohibited operations are represented by the red shaded area. The curved, dashed lines represent the airspeeds at which the aircraft will stall at various g-loads. Note that the intersection of the dashed line with the 1-g line indicates the stalling speed in straight and level flight.

**WARNING:** The area shaded red represents operation beyond the structural capabilities of the aircraft. Such operation will result in complete structural failure of one or more airframe components.

## CENTER-OF-GRAVITY LIMITATIONS

Location of the center of gravity (cg) of the aircraft is expressed in terms of inches aft of the datum line, which is 10 inches forward of the nose. The forward cg limit is 74.75 inches aft of the datum (17 percent MAC), and the rearward cg limit is 76.97 inches aft of the datum (25 percent MAC). The full range of cg travel can be obtained with various combinations of pilot and fuel weights. The cg limits shown are with gear down; landing gear retraction moves the cg aft 2.4 percent MAC, but will not result in an abnormal cg position. Use the loading information in Figure 5-3 carefully for each flight with a different loading.

**CAUTION:** Calculate both the takeoff and landing configuration cg position for each flight with a new type of loading, pilot weight, etc.

## LOADING LIMITATIONS

Loading diagrams and sample loading problems are included in Figure 5-3.

**CAUTION:** Modifications and variations in equipment will cause considerable shifting of the aircraft empty weight and cg location. Always use the weight and cg location peculiar to each aircraft. Optional radio and instruments installed may eliminate any need for ballast.

1. Determine the Empty Weight of the Aircraft From Weighing Data
2. Determine the Empty Moment of the Aircraft From Weighing Data
3. Determine Pilot Weight
4. Find Pilot Moment From Loading Chart
5. Determine Amount of Ballast Required From Ballast Chart
6. Find Ballast Moment From Loading Chart.
7. Enter Fuel Weight From Loading Chart.
8. Enter Fuel Moment From Loading Chart
9. Add Up Total Weight
10. Add Up Total Moment
11. Find Total Weight and Moment on Weight Vs Moment Chart

ITEM	WEIGHT (LBS)	MOMENT (1000 IN-LB)
Empty	1	2
Pilot	3	4
Ballast	5	6
Fuel	7	8
TOTAL	9	10

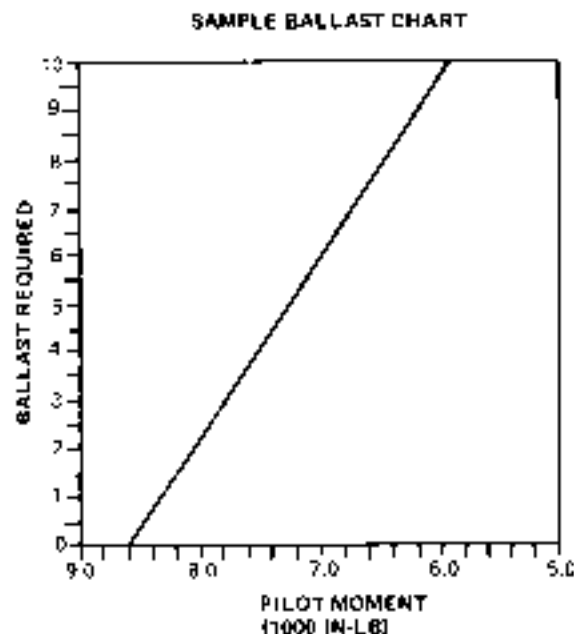

Figure 5-3A Weight and Balance

**LIGHT PILOT  
TAKEOFF CONDITION**

ITEM	WEIGHT	MOMENT (1000 IN-LB)
Empty Aircraft	435.3*	36.38
Fuel	135.0 (22.5 Gal)	10.93
Pilot	120.0	6.36
Ballast	8.3	.10
Total	698.6	53.77

**LANDING CONDITION**

ITEM	WEIGHT	MOMENT
Empty Aircraft	435.3*	36.38
Fuel	5.0 (1 Gal)	.49
Pilot	120.0	6.36
Ballast	8.3	.10
Total	569.6	43.33

**HEAVY PILOT  
TAKEOFF CONDITION**

ITEM	WEIGHT	MOMENT
Empty Aircraft	435.3*	36.38
Fuel	54.7 (9.1 Gal)	4.43
Pilot	220.0	12.75
Ballast	0	0
Total	710.0	53.56

**LANDING CONDITION**

ITEM	WEIGHT	MOMENT
Empty Aircraft	435.3*	36.38
Fuel	6.0 (1 Gal)	.49
Pilot	220.0	12.75
Ballast	0	0
Total	661.3	49.62

\*Includes Electrical System

Figure 5-3B Weight and Balance Sample (BD-5B)



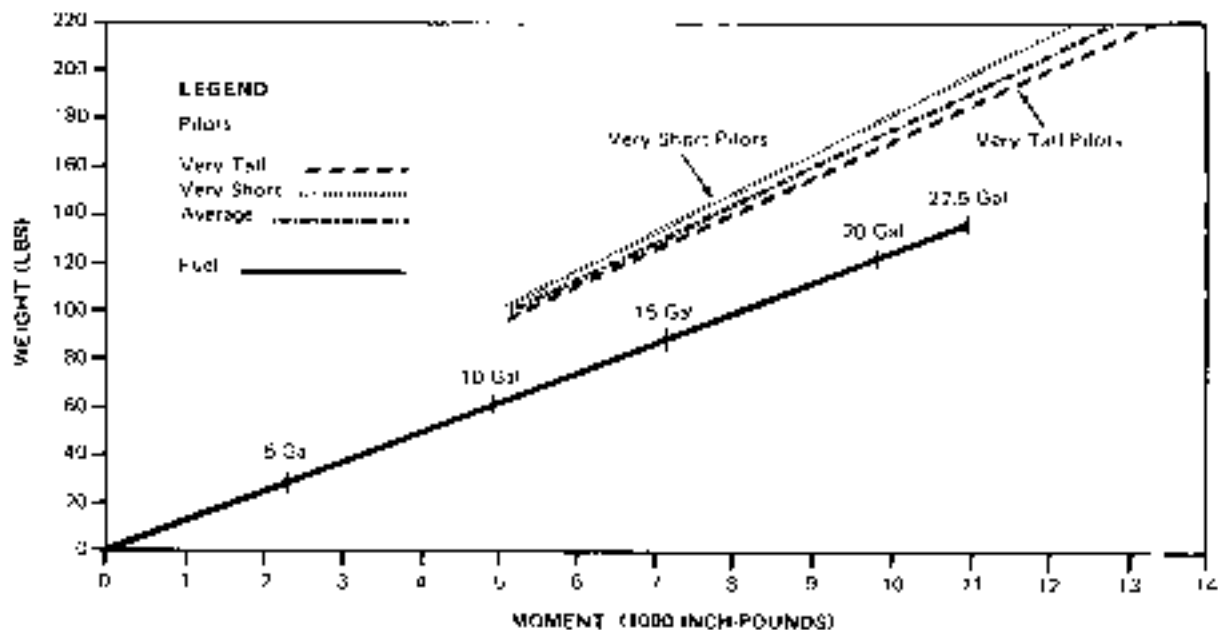
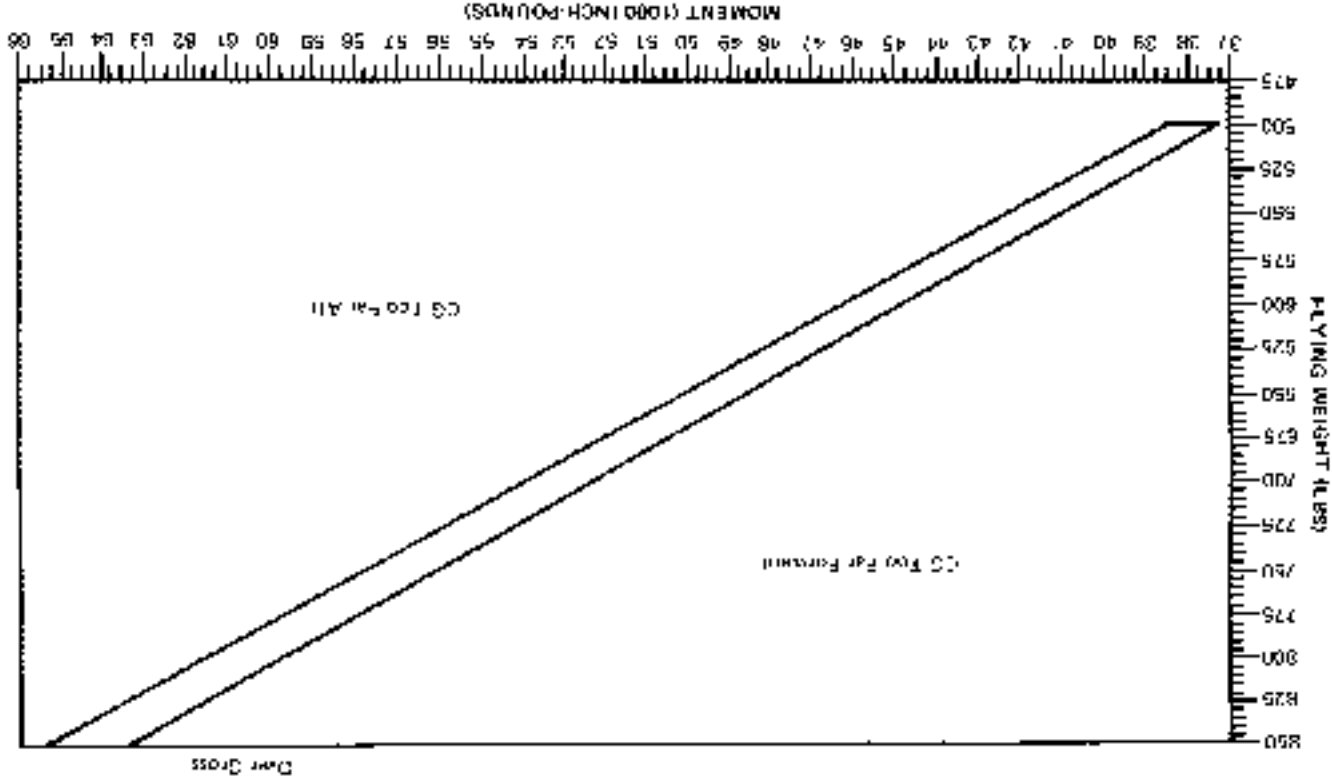

Figure 5-3C Weight and Balance

Figure 5-5D Weight and Balance



<https://aircraftmanual.jimdofree.com/>

## OPERATING LIMITATIONS

This BD-5D aircraft is certified in the utility category, and the BD-5B/G in the experimental homebuilt category. Limited aerobatic maneuvers are approved as follows:

Maneuver	Entry IAS
Chandelle	180
Wingover	160
Lazy 8	160
Aileron Roll	180
Barrel Roll	180
Loop	190
Immelman	200
Cuban 8	200
Spin	Use slow deceleration

Maximum acceleration +4.4 g, -1.76 g.

Maneuvering speed ( $V_a$ ) 145 mph.

NOTES:

<https://aircraftmanual.jimdofree.com/>

## SECTION 6-FLIGHT CHARACTERISTICS

---

### CONTENTS

General Flight Characteristics .....	6-1
Aerobatics .....	6-2
Stalls .....	6-3
Spins .....	6-5
Diving .....	6-8
Summary .....	6-8

### GENERAL FLIGHT CHARACTERISTICS

The flying qualities of the BD-5 are characterized by excellent stability and handling characteristics and high maneuverability. When properly trimmed, the aircraft tends to maintain straight and level flight, and the controls are effective throughout the speed range from stall to maximum drive speed.

Control forces are light and response to the controls is rapid and definite, without being too sensitive. This makes the aircraft excellent for aerobatics; however, due to the light elevator forces, it is recommended that the trim not be used to reduce stick forces during maneuvers, since only slight additional stick forces would then be required to exceed the maximum allowable g-limits. The aircraft is very clean aerodynamically and picks up speed rapidly with the nose down. The light rudder forces permit holding the aircraft straight in a dive to  $V_{ne}$  without rudder trim.

**AEROBATICS**

Even though the BD-5J is licensed in the utility category and the BD-5B/C in the experimental homebuilt category they will perform most normal aerobatics with ease. Because of the +4.4 g-limit, however, more attention should be paid to proper entry airspeeds and control usage. Unless an error is made, there is no reason to pull more than 4 g's in any basic aerobatic maneuver. Because of the probability of errors during training, however, it is highly recommended that aerobatics be learned in another aircraft before being flown in the BD-5.

Use of the aircraft at speeds consistently exceeding 4 g's will cause the upper wing skin to permanently wrinkle chord-wise near the leading edge. This is cosmetic damage only and does not affect the strength of the wing or the flying qualities of the aircraft.

**NOTE:**

The elevator trim is effective at all flight conditions and very little change in trim is required for landing gear and flap extension or retraction or changes in power. Because of the high level of longitudinal stability the trim required will vary noticeably with large speed changes; the pilot can however, easily override any out-of-trim condition by holding stick forces. The trim rate and authority are such that a landing can be made without using the side stick at all. The rudder can be used for roll and directional control; the trim and power for pitch control, and a normal pattern and landing can be made.

The controls are well harmonized and there is very little adverse yaw at cruising speed. Coordination is very easy and there is adequate rudder power available to counteract the adverse yaw resulting from full aileron deflection down to 80 mph IAS.

The following entry speeds are recommended for aerobatic maneuvers:

Maneuver	Entry IAS
Chandelle	180
Wingover	180
Lazy 8	160
Aileron Roll	180
Barrel Roll	180
Loop	190
Immelman	200
Cuban 8	200

## STALLS

The first indication of an excessive angle of attack in the B17-5 is a moderate intensity high frequency buffet which (at 710 lbs.) begins at about 72 mph and increases in intensity until full aft stick is reached at approximately 68 mph. As the speed decreases through 70 mph, transient lateral roll-offs begin to occur. These roll-offs are easily controllable, however, with normal use of rudder and aileron until full aft stick is reached. No g-break occurs and with the stick held full aft, the airspeed begins to increase from its minimum of 68 mph IAS. The lateral roll-offs become increasingly pronounced as airspeed increases and after approximately 15 seconds and at 90 mph IAS, the aircraft will depart laterally either left or right, and the back pressure on the stick has to be relaxed for recovery.

Full throttle and/or aft cg (27 percent MAC) has very little effect on the stall characteristics, except that the full throttle stall occurs at a higher nose attitude and the aft cg stall takes 20 seconds from full aft stick to departure instead of 15. The airspeeds at buffet and at full aft stick are essentially unchanged.

### Accelerated Stalls

Accelerated stalls have been performed in the BD-5 from 90 mph up to 145 mph and 4.4 g (the limit load factor). The aircraft has been stalled in both steep turns and in straight pull-ups with no apparent difference in characteristics due to turning. In all cases, a moderate-to-heavy buffet occurs well before any loss of control and provides more than adequate stall warning. If, after entry into buffet, the stick is pulled full aft, there will still be no g-break. At the same time the aft stop is reached, however, the aircraft will depart smartly, usually to the left. The abruptness of the roll-off and the resulting roll rate are generally proportional to the entry airspeed. Again, recovery is immediate upon relaxation of back pressure. Throttle setting and cg location have very little effect on the accelerated stall characteristics.

**CAUTION:** The application of full aft stick at any airspeed greater than 90 mph will cause the stabilizer anti-servo tab to blow down and the trim lever will move to its full aft position. On all accelerated maneuvers it is necessary to hold the trim lever at its original position.

### Stalls With Gear and Flaps Down

The effect of lowering the landing gear and/or flaps is to increase the nose-down, aerodynamic pitching moment, thereby restricting the angle of attack of the wing due to the decrease in stabilator power. With half flaps and idle power, minimum airspeed is 64 mph IAS. With the stick held full aft, airspeed will increase to 80 mph IAS and stabilize. The lateral roll-offs are still present, but with the proper control inputs the bank excursions can be held to +10 degrees of wings-level. With full flaps, there is only a slight tendency to roll off and the wings can be held level. In this configuration, the stabilator is not powerful enough to hold the aircraft in buffet, and the nose will pitch up and down, in and out of buffet in a "bucking motion,"  $\pm 10$  degrees from level at a frequency of about 1½ cps.

Putting the gear down makes the stall more docile. With gear down and full flaps, the aircraft can be held wings-level in moderate buffet with full aft stick at a constant airspeed of 65 mph. Rate of descent in this configuration at idle power is 1000 to 1500 ft/min. With gear down and full flaps, full aft stick is inadequate to keep the aircraft in buffet, and the "bucking motion" is again present, but with a larger



amplitude of +20 degrees at the same frequency of 1½ cps. Airspeed and rate of descent are, respectively, 60 mph IAS and 1500 to 2000 ft/min. Recovery is immediate upon relaxation of back pressure. A properly rigged aircraft will not stall inverted, and with full forward stick and full rudder will simply make an inverted flat turn with no tendency to depart.

#### **Aggravated Stalls**

The first motion of the aircraft following a full aft stick, full rudder deflection stall is primarily a rolling motion in the direction of the rudder input. Recovery after a one-second delay puts the aircraft in about a 90-degree bank. When full aileron is added with the rudder, the roll-off is amplified so that recovery occurs inverted. Full aileron against the rudder will stop the roll-off so that the aircraft will remain in a large amplitude sideslip for about five seconds and then roll in the direction of the aileron.

The effect of lowering gear and flaps is to make the roll-offs more docile, but otherwise the characteristics are the same.

Accelerated stalls with the same combinations rudder and aileron deflection have similar characteristics but with roll and yaw rates generally proportional to load factor at departure. Recoveries are immediate with neutralized controls.

#### **SPINS**

In the BD-5, as in any experimental aircraft, a parachute should be worn during all acrobatic flights, including spins. Intentional spins in the BD-5 should be entered from a power-off stall. Back stick pressure should be continued through the buffet, and just as full aft stick is reached, full rudder added in the direction of desired rotation. As with the aggravated stalls, the first turn of a normal spin is primarily a roll. The nose drops to the horizon at 90 degrees of bank, slightly below the horizon at inverted, and remains at this attitude for the rest of the first turn. The first turn is quite gentle and recovery can be made by simply neutralizing the controls; the spin will stop in less than one quarter of a turn.

As the second turn begins, the rotation rate increases, the nose drops smartly, and halfway through is pointed almost straight down. The nose then starts back up, and at the end of the second turn is about 45 degrees below the horizon. Recovery is immediate if the controls are neutralized.

In the third and succeeding turns, the pitch attitude continues to oscillate between 60 degrees and 45 degrees nose down, once per revolution. The rotation rate increases up to the fourth turn and remains stable thereafter. If a stable spin is not achieved after three turns, execute a recovery maneuver. Airspeed also increases up to the fourth turn, and the stabilized spin mode is at 100 to 110 mph and 2.5 g. Although the average rotation rate in the stabilized spin is 200 to 300 degrees/second, it is possible to maintain visual orientation and keep up with the number of turns. After the fourth turn, there is no apparent change in the spin or the recovery up to 15 turns in each direction. After the second turn, neutral controls will not stop the spin, and it is necessary to apply anti-spin controls. As a general practice, spinning more than three rotations is not recommended, due to the high rotation rate.

### Spin Recovery

Flight tests have shown that both aileron and elevator are very effective in spin recovery and that the rudder is the weakest control. During a spin or deep stall, the airflow over the wing forward of the ailerons does not separate. Consequently, the ailerons remain effective and work in the correct direction throughout the spin. Aileron against the spin will always decrease the rate and if held, will recover the aircraft from the spin in three turns, even with full aft stick and pro-spin rudder. Likewise, full forward stick will stop the spin in one turn (even with pro-spin aileron and rudder) although this recovery results in a vertical diving aileron roll. Rudder only against the spin will slow down the rate slightly but will not result in a recovery. Adding power makes the spin steeper and increases the airspeed and rotation rate but will not recover the aircraft alone. If the controls are released after the fourth turn, the rotation rate will almost double, increasing to 400 to 500 degrees/second, with no tendency toward recovery. The nosedown attitude remains constant, however, and the aircraft will recover immediately from this accelerated mode with normal recovery controls. The optimum spin recovery control inputs for any mode or configuration are simultaneous full anti-spin rudder and a brisk forward

stick movement to just forward of neutral. The buffeting and rotation stop simultaneously and the aircraft recovers in a 60 degree to 70 degree nose-down attitude. If recovery controls are input at the nose-high (45 degree nose-down) point in the spin, the rotation will stop in one-quarter of a turn; if recovery is initiated at the steep part of the spin (60 degree, nose-down), recovery takes up to one-half of a turn. If recovery controls are put in slowly, the accelerated mode will begin and up to two turns can be required for recovery. However, if the recovery control inputs are brisk (one second or less from pro-to anti-spin controls), the recovery from either mode is immediate. The altitude loss during the stabilized spin is approximately 300 feet per turn. Recovery from the resulting dive with a 3-g pullout requires an additional 1000 feet. A ten-turn spin and recovery requires 4000 feet.

### **Snap Rolls**

A snap roll is basically just a high-g horizontal spin. The entry and recovery are the same as for normal spins, although the resulting roll rate and g-load will be proportional to the entry airspeed.

When stabilized at the desired airspeed, briskly apply full aft stick and full rudder in the desired direction of rotation, and hold this control position until 90 degrees of roll before the desired recovery attitude. Then, briskly apply full opposite rudder and forward stick, neutralizing both as the buffeting and rolling cease. A fair amount of practice is required to be able to consistently recover at a desired attitude. Start at low speed (90 mph) first and work your way up; a 4-g snap is a pretty spectacular maneuver, with roll rates greater than 400 degrees per second. Snap rolls are prohibited with more than five gallons of fuel in each wing.

Snap rolls put a large amount of vibratory, airload, and inertial stress on the airframe and will significantly reduce the fatigue life of the aircraft.

## DIVING

Since the aircraft is very clean aerodynamically, care should be taken not to exceed the airspeed redline (230 mph IAS). The throttle should be retarded to idle during high speed descents. With the overrunning clutch, the engine will remain at idle, and the propeller rpm will limit itself when the prop tip mach number becomes high enough. The only items the pilot has to monitor are airspeed and CHT, to prevent the engine from overcooling.

## SUMMARY

1. BD-5B/D/G stall characteristics are normal and straight-forward. There is inadequate elevator power to cause a g-break and the stall consists mainly of a lateral departure once full-aft stick is reached. It is not possible to stall a properly rigged aircraft inverted.
2. Lowering gear, flaps, or adding power makes the stall more docile.
3. The BD-5B/D/G has no unrecoverable spin modes and is qualified for an unlimited number of spin turns.
4. Snap rolls are approved with less than five gallons of fuel in each wing.
5. Optimum recovery controls for any condition are simultaneous full anti-spin rudder and brisk forward stick.
6. Releasing or neutralizing the controls after one turn of the spin will result in an accelerated mode without stopping the spin.
7. Spins with gear and flaps down are more docile. Flaps must be raised during the recovery to prevent exceeding flap limit airspeed.

## SECTION 7—SYSTEMS OPERATION

---

### CONTENTS

Introduction .....	7-1
Engine .....	7-1
Power Transmission System .....	7-5
Fuel System .....	7-6
Control System .....	7-6
Electrical System .....	7-6
Landing Wheel Brake System .....	7-7
Landing Gear System .....	7-8

### INTRODUCTION

A thorough understanding of each system aboard a BD-5 is essential for safe operation. Correct operating procedures will result in an increase in service life, economy, and safety.

### ENGINE

The BD-5 is unique among present day high performance aircraft in its use of a two-cycle power plant. This power plant is light in weight, has a high power-to-weight ratio, and has inherent mechanical reliability due to its small number of moving parts. However, the aerothermodynamic events occurring within the engine are complex in nature, and can be upset by improper operating techniques. Therefore, strict adherence to the correct operating procedures for the conditions encountered is necessary for engine dependability.

### Gasoline/Oil Mixture

Operation of the two-cycle engine differs from a conventional four-cycle engine in several important respects. The most obvious of these differences is its need for a gasoline/oil mixture. The Xenoah power plant has no oil sump, and oil must never be added to the engine crankcase. To provide lubrication to the engine's moving parts, the oil tank must be filled with a two-cycle engine oil of a brand recommended by Bede Aircraft, each time gasoline is added to the wing tanks. The engine is approved for only 100/115 octane low lead aviation fuel.

**CAUTION:** Each time fuel is added to the wings, the oil tank should be filled to within 1/4 quart of full, to ensure a sufficient supply of oil.

**NOTE:** Some engines (upon customer request) may not be equipped with an oil injection system. In this case the oil must be mixed with the fuel prior to putting it in the aircraft fuel tanks. Fuel and oil should be mixed at 25 parts fuel to 1 part oil.

### Fuel/Air Mixture Control

Unlike a four-cycle engine, a Xenoah two-cycle engine must never be leaned beyond the best power mixture, or engine overheating and probable piston seizure will occur. Insufficient lubrication is delivered to the engine beyond the best power setting when the mixture control is turned toward lean, since not only the gasoline/air mixture but also the oil/air mixture is reduced. As a result the mixture control is only used to control the engine temperature and smooth operation, not fuel flow. Practice will enable you to find a mixture control setting which will give good engine efficiency at different altitudes. Keep in mind that although mixture will tend to be overrich at altitude with the mixture control in FULL RICH, an overrich mixture is preferable to a lean setting. Be particularly conscious of the mixture setting whenever it is leaned, especially during descents.

**CAUTION:** A two-cycle engine must not be leaned past the best power mixture, and the only indication of an excessively lean setting will be high cylinder head and/or exhaust gas temperature. Maximum EGT temperature is 1050°F.

A two-cycle engine which is excessively rich loses power and enters a "four-cycling" condition, which is characterized by the engine running rough and firing intermittently. During a low power/high speed descent, this is a normal condition. This "four-cycling" condition can be used at altitude as a mixture setting reference point. In a climb to high altitude, a "four-cycling" will be encountered at some altitude if the mixture control is left FULL RICH. At this altitude, the mixture must be leaned in order to cruise or continue climbing. At this altitude and higher altitude (the indicated altitude will vary with temperature and humidity), the mixture control should either be placed 1/8-turn leaner than the "four-cycling" reference point, or set to EGT = 1000°F, if an EGT system is available.

#### **Spark Plug Fouling**

Spark plug fouling, which is an accumulation of deposits which cause misfiring or prevent firing across the spark plug electrodes, can have several causes. Lead fouling is due to the tetraethyl lead found in most brands of gasoline. If lead fouling should occur in flight and cause misfiring, each ignition circuit should be checked, and the unfouled circuit selected for the duration of the flight. The fouled plug must be replaced or cleaned before the next flight. Carbon

fouling is generally caused by prolonged ground running at low power. Ground running time should be kept to a minimum to avoid carbon fouling of spark plugs.

#### **Exhaust System**

The Xenosah engine exhaust system consists of an expansion chamber which leads into a venturi duct. The chamber is shock mounted and isolated from engine vibration by gimbal joints. The exhaust system has been carefully matched to the engine to produce the desired performance. Any change in the exhaust system will cause the fuel/air mixture to become non-linear with rpm, thus requiring an internal change in carburetor mixture calibration. Under no circumstances should the exhaust system of a BD-5 be modified in any way.

#### **Cooling System**

Ground cooling is provided by the exhaust gases passing through the venturi duct and drawing air along with it from the engine compartment. As with most tightly cowled aircraft engines, prolonged ground operation should be avoided to prevent overheating. Engine run-up should be performed into the wind, and the throttle should be used sparingly while taxiing.

Inflight cooling is provided by an air-scoop on the bottom of the BD-5 fuselage.

### Engine Instrumentation

Cockpit engine instrumentation in the BD-5 includes a tachometer, a cylinder head temperature gage, or exhaust gas temperature gage and a fuel pressure gage. The tachometer red-line rpm is 6250. Care should be taken to never exceed this rpm in flight, particularly in high speed descents, since engine damage can result. The cylinder head temperature redline is 440°F, and operation above this temperature can also result in engine damage. Overheating in flight should be corrected by applying FULL RICH mixture, reducing the power setting, and increasing the airspeed to supply more cooling air.

The fuel pressure gage is connected to the carburetor interconnection line, and senses the fuel pressure in all three carburetors. The normal pressure (2 to 4.5 psi) will drop suddenly to half its normal value in the event of a fuel pump failure.

### Ignition System

A dual-capacitor discharge ignition system fires the six spark plugs, two of which are in each cylinder.

The front and rear spark plug on each cylinder are connected to completely independent ignition circuits. Cockpit switches control each ignition circuit, and can be set so that the engine runs on either or both circuits.

### Induction System

A foam air filter provides clean air to the carburetors. The carburetors are enclosed in a fireproof box which also serves as a plenum chamber for the incoming air. If icing conditions are encountered, the foam air filter may become blocked, and the carburetor heat door must be opened to supply alternate air. The carburetors are resistant to the formation of carburetor ice. In moist cold air, however, an unexplained drop in rpm will signal the formation of carburetor ice, and carburetor heat must be applied until normal rpm is recovered with the heat control off.

### Preventive Maintenance

The engine manufacturer recommends that all external nuts and bolts be retightened after the first hour of engine operation. Spark plugs will normally last 35 hours, with cleaning and regapping to .020 inch possibly necessary at 25 hours. Each time a



spark plug is removed, a new spark plug gasket must be installed. Nominal spark plug torque is 18 foot-pounds, with anti-seize compound applied to the threads. If the plugs have been cleaned, be sure that all cleaning grit is removed from the threads. Care must be taken to not damage the cylinder head temperature thermocouple rings and wires when removing and installing the spark plugs. The foam air filter generally needs cleaning in gasoline at 25 hours, depending on operating conditions. The fuel filter requires replacement every 100 hours. At approximately 500 hours, the engine will need a top overhaul, which is replacement of the piston, wrist pin clips, upper rod bearings, rings, and possibly cylinder and head, depending on wear.

#### **Run-In Procedures**

The Xenosah engine should be run at a low power setting (2000 to 3000 rpm) for the first 30 minutes of operation. A cooling fan should be directed into the air scoop to keep cylinder head temperature below 425°F.

#### **Normal Operation**

The power settings for takeoff, climb, and maximum continuous power are identical for this engine (full

throttle). However, this does not imply that the engine is designed to operate wide open at all times. Continued use of extreme high power substantially shortens engine life by increasing wear, and the higher loads and temperatures reduce the safety margin of your operation. Full throttle should be a normal operation for takeoff and climb only. Climb and cruise charts are to be consulted for normal power settings in prevailing conditions. The greatest engine efficiency and reliability can be gained by using the lowest power setting consistent with the desired performance. Gradual power changes place the least amount of stress on the engine. Rapid power changes can cause extreme temperature differences and cause damage to the engine. The maximum recommended cruise power condition is 75 percent of full power.

#### **POWER TRANSMISSION SYSTEM**

The power transmission system consists of a lower drive shaft and two, soft-rubber couplings connected to the engine: a toothed belt and two pulleys which reduce the speed of the propeller by a ratio of 1.6 to 1; a one-way clutch which eliminates torsioned vibrations during engine start-up; and, a lightweight, upper driveshaft going back to the propeller. This lightweight, highly efficient power transmission system is virtually maintenance free.

## FUEL SYSTEM

Proper preflight fuel planning is the main prerequisite for use of this system. Each wing is a fuel tank, which feeds through a right/left fuel selector valve to a fuel filter, two engine-driven pumps, and then to the carburetors. A fuel pressure gage registers the fuel pressure entering all three carburetors. The fuel gages read accurately only in level flight; for more accurate and dependable determination of fuel remaining, use fuel consumption data based on known operating conditions. Fuel capacity of the BD-5B is 26 gallons, BD-5D/G 29 gallons. BD-5 fuel, which is a gasoline/oil mixture, weighs 5.9 pounds per gallon. The position of the right/left selector valve should be changed after every half hour of flight to maintain lateral balance. The fuel selector valve OFF position is mainly for use during emergency power-off landings and for extinguishing engine compartment fuel fire.

## CONTROL SYSTEM

A side stick controller is utilized in the BD-5 control system. The pilot sits in a semi-reclined position, and his right hand grasps the side stick located on the

right armrest console. As in a conventional, center-stick design, side-to-side motion controls ailerons (roll), fore-aft motion controls the horizontal stabilizer (pitch). Advantages of a side stick include more precise control of the aircraft with a significant reduction in pilot workload. The left hand operates the throttle, and the fingertips reach around the throttle to adjust the trim. A friction lock on the left console can be turned clockwise to increase the trim and throttle friction. The feet operate conventional rudder pedals with toe brakes. The flap system is operated by a handle located between the legs and to the left of the landing gear handle. Maximum flap deflection is 40 degrees. To raise the flaps, pull rearward and outboard on the handle and allow it to return to the forward position.

## ELECTRICAL SYSTEM

The ammeter located on the right console indicates the charging (or discharging) rate of the battery. If a discharge condition is noticed, electrical load on the system should be reduced to a minimum or, preferably, the master switch should be turned OFF. Circuit breakers which open should not be reset unless the cause is known.

## LANDING WHEEL BRAKE SYSTEM

The hydraulic brake system is operated by applying pressure with the toes to the top of the rudder pedals. The use of care when applying brakes will minimize wear and achieve the longest useful service. Careful application of the brakes immediately after touch-down or at any time when there is considerable lift on the wings, will prevent skidding of the tires which causes flat wear spots. The brakes, which are a dual-puck disc type, can stop the wheel from turning entirely; however, for optimum braking the tire should be in a 15 to 20 percent rolling skid, i.e., the wheel continues to rotate but has approximately 15 to 20 percent slippage on the surface so that rotational speed is 80 to 85 percent of a free roll. Beyond this amount of skid, the coefficient of friction (braking action) decreases. Normally, a full landing roll should be utilized to take advantage of aerodynamic braking and to use the brakes as little and as lightly as possible. For maximum braking, lift should first be decreased by raising the flaps and lowering the nose before applying the brakes. For short

landing rolls, a single, smooth application with constantly increasing pedal pressure is most desirable. If the brakes have been used excessively for an emergency stop and are in an overheated condition, taxi operations should be conducted cautiously and at reduced speed, since possible brake fading may occur.

### Ground Steering

Ground maneuvering of the BD-5 is accomplished by differential braking. For least brake wear the rudder should be deflected to its stop in the direction of turn before applying brake. The BD-5 has a free-castering nosewheel and can turn in a tighter radius than most other aircraft.

## LANDING GEAR SYSTEM

A large handle located between the pilot's legs actuates the landing gear. Since the landing gear are mechanically actuated, no emergency extension system is necessary. The actuation time is the fastest of any light aircraft. A rearward motion of the handle swings the gear into an up and locked position, and a forward pushing motion swings the spring-assisted gear into a down and locked position. Each landing gear over center link has a switch which illuminates a green light on the right console when the strut is down and locked. If a light does not come on when the gear is lowered in flight, first give an extra push forward on the landing gear handle. If no light appears, check the bulb by switching it with another. If the bulb was not burned out, try recycling the gear, and if this fails to illuminate the light, consult

Section 3, Emergency Procedures. The landing gear warning consists of a horn (BD-5D only), which actuates when the throttle is retarded to one-quarter or less (as must be done for a landing), and the gear is in the up position. The horn stops when the gear is down and locked. On the BD-5D, the horn also will sound when the flaps are extended while the gear is in the up position.

## SECTION 8-ALL WEATHER OPERATION\_\_\_\_\_

### CONTENTS

Introduction .....	8-1
Instrument Flight Procedures .....	8-2
IFR Takeoff .....	8-2
IFR Climb.....	8-3
IFR Cruise.....	8-3
IFR Descent .....	8-4
Instrument Approaches.....	8-4
Ice and Rain .....	8-8
Turbulence and Thunderstorms .....	8-8
Night Flight .....	8-9
Cold Weather Operation .....	8-9
Hot Weather and Desert Operation .....	8-11

### INTRODUCTION

Except for some repetition necessary for emphasis, clarity, or continuity of thought, this section contains only those procedures that differ or are in addition to the normal operation instructions covered Section 2. Systems operations are covered in Section 7.

## INSTRUMENT FLIGHT PROCEDURES

**NOTE:** The basic BD-5B/D/G model aircraft is equipped for VFR operations only. This section assumes that a full instrument/avionics package has been added to the aircraft.

This airplane has the same stability and handling characteristics during Instrument Flight Conditions as when flown under VFR conditions. However, like most single engine aircraft, it requires constant attention to the indications of the flight instruments. The stability, flight strength, instruments, and communications equipment are sufficient for instrument cross-country flights under most weather conditions. Flight in icing conditions should not be attempted as there are no provisions for deicing. The following techniques are recommended from takeoff to touchdown under instrument conditions.

### IFR TAKEOFF

Complete the normal TAXI and PRE-TAXI-OFF check as described in Section 2. If taxiing and take-off are to be made in visible moisture, a check for indication of carburetor icing should be made.

**NOTE:** A drop in engine rpm or an increase in engine roughness are good indications of carburetor icing.

If carburetor icing is indicated, adjust the carburetor heat knob to provide heat for deicing prior to takeoff; return the heat control to the COLD position just prior to the takeoff roll. After lifting off the runway and establishing the initial climb, carburetor heat may be reapplied as required.

**NOTE:** When visible moisture is present, turn pitot heat switch ON just prior to beginning takeoff roll.

After taxiing into takeoff position set the directional gyro to the runway heading. Crosscheck the directional gyro setting with the magnetic compass and note any discrepancy.

**NOTE:** To be certain of proper operation of the gyro instruments, allow three minutes minimum for them to reach full operating speed.

Apply full power by smoothly advancing the throttle to the OPEN position and release the brakes. Use differential braking for directional control until the rudder becomes effective at approximately 35 mph. During the takeoff roll the directional gyro is the primary instrument for maintaining directional control; however, while runway markings remain visible they should be used as an aid in maintaining heading. At approximately 65 mph IAS apply back pressure to the stick to establish a takeoff attitude of about two horizon bar widths nose high on the attitude indicator. As the aircraft leaves the ground the attitude indicator is the primary instrument for pitch and bank and continues to be until the climb is established. When the altimeter and vertical speed indicator indicate a climb, retract the landing gear and maintain a one bar width climb until the desired climb speed is obtained.

#### **IFR CLIMB**

Maintain best rate of climb speed by cross-referencing the airspeed indicator and altitude indicator. If the aircraft is equipped with the optional angle-of-attack system the climb may be optimized by adjusting the

aircraft attitude to give an angle-of-attack indication on the blue line (best rate of climb). Turns should not be attempted below 500 feet AGL and the angle of bank should not exceed 30 degrees while establishing the climb. Maintain directional control with reference to the directional gyro and, as the climb airspeed stabilizes at approximately 100 mph IAS, adjust the aircraft trim to maintain this airspeed for best rate of climb. Use carburetor heat as required when induction system icing is indicated.

#### **IFR CRUISE**

After leveling off at the desired altitude, it is recommended that full power be maintained until cruising airspeed is established. It is seldom necessary in routine flight to exceed a 30 degree angle of bank; however, the aircraft can easily be controlled in turns up to 60 degrees of bank.

**NOTE:** The directional gyro should be cross-checked with the magnetic compass at least once every 15 minutes and reset as required.

The use of pitot heat should be liberal when conditions indicate that icing is possible. Under most conditions the cockpit heater will be sufficient to keep the canopy clear; however, in the event of heavy fogging inside the canopy the outside air vent may be opened to clear the fogging.

**NOTE:** Avoid opening the outside air vent while flying through rain.

#### **IFR DESCENT**

Slow the aircraft to the desired descent airspeed before initiating the descent since it is difficult to slow the aircraft once the descent is established. Check mixture, carburetor heat, pitot heat, and re-trim as necessary. Complete the normal pre-traffic pattern checks prior to initiating an approach to landing.

#### **INSTRUMENT APPROACHES**

Since the aircraft is not equipped with ADF or DME equipment, approach procedures utilizing these instruments are not available. VHF Omni-range approaches, ILS Localizer/Localizer Backcourse approaches, Precision Radar approaches, and ILS approaches are available. Flying the aircraft on instrument approaches is not difficult due to the excellent stability and low stalling speeds. Always reduce airspeed well in advance of necessary airspeed changes. Proper trim technique is very important during approaches; with each change in power, attitude, configuration, or airspeed it is necessary to retrim the aircraft in order to avoid the need for holding constant control pressures.



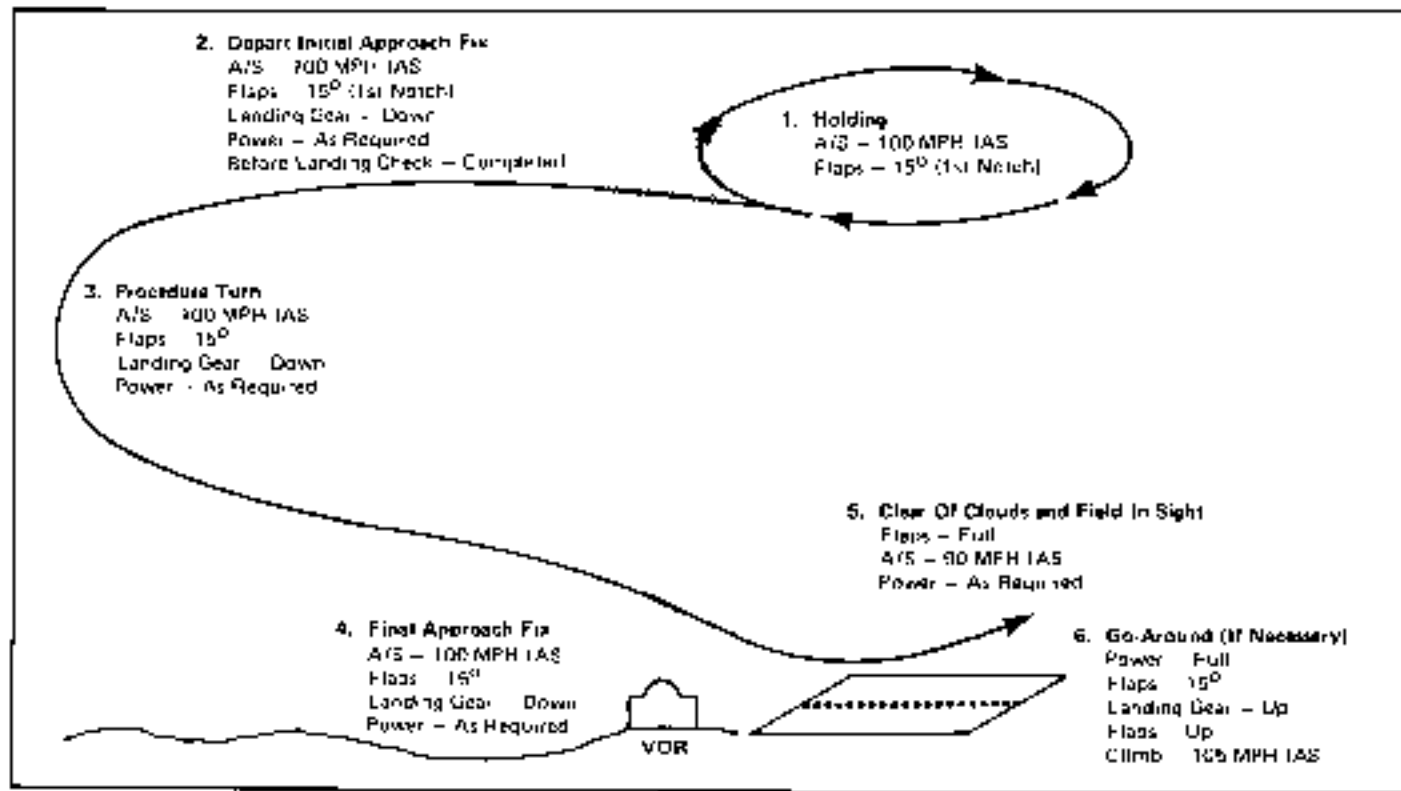

Figure B-1 VOR Approach

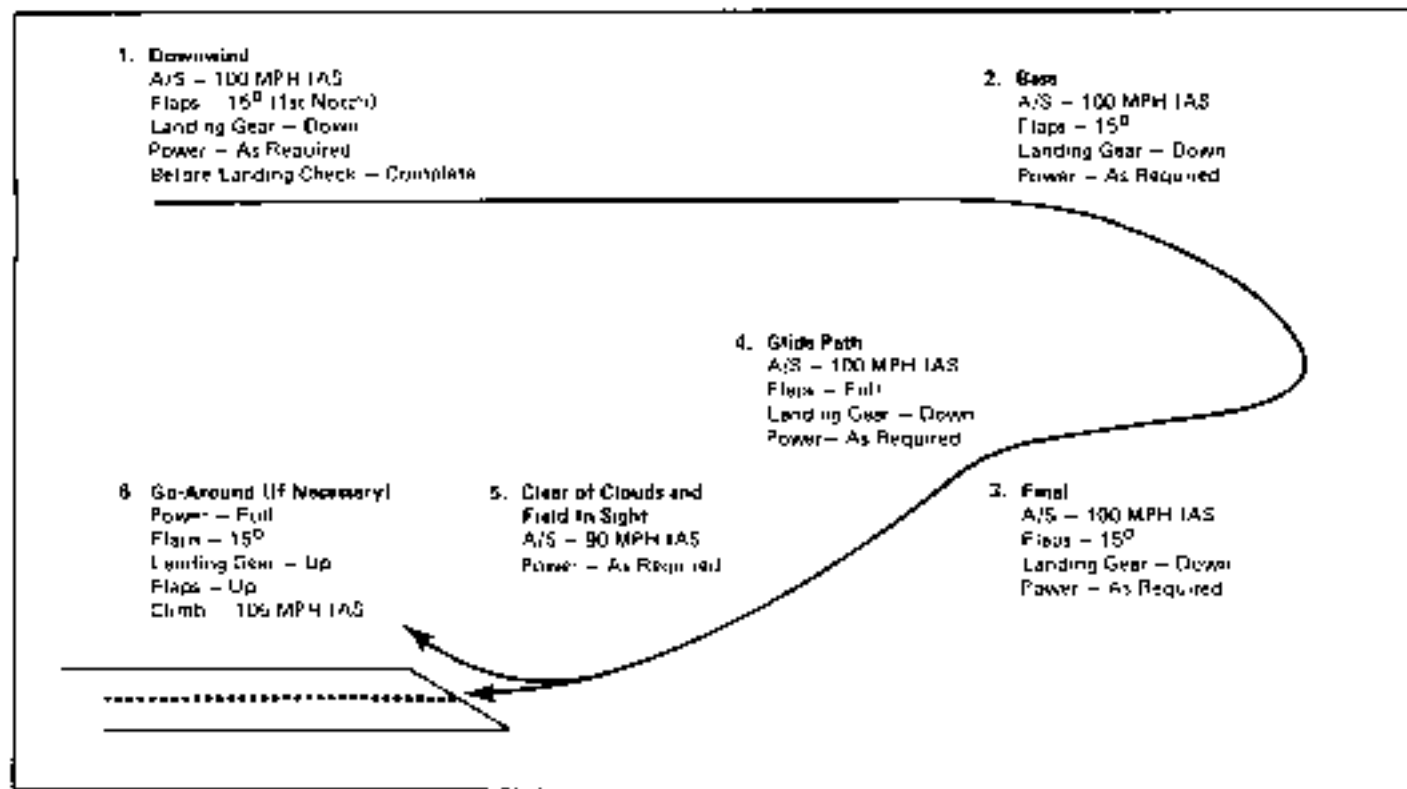

Figure 8-2 PAR Approach

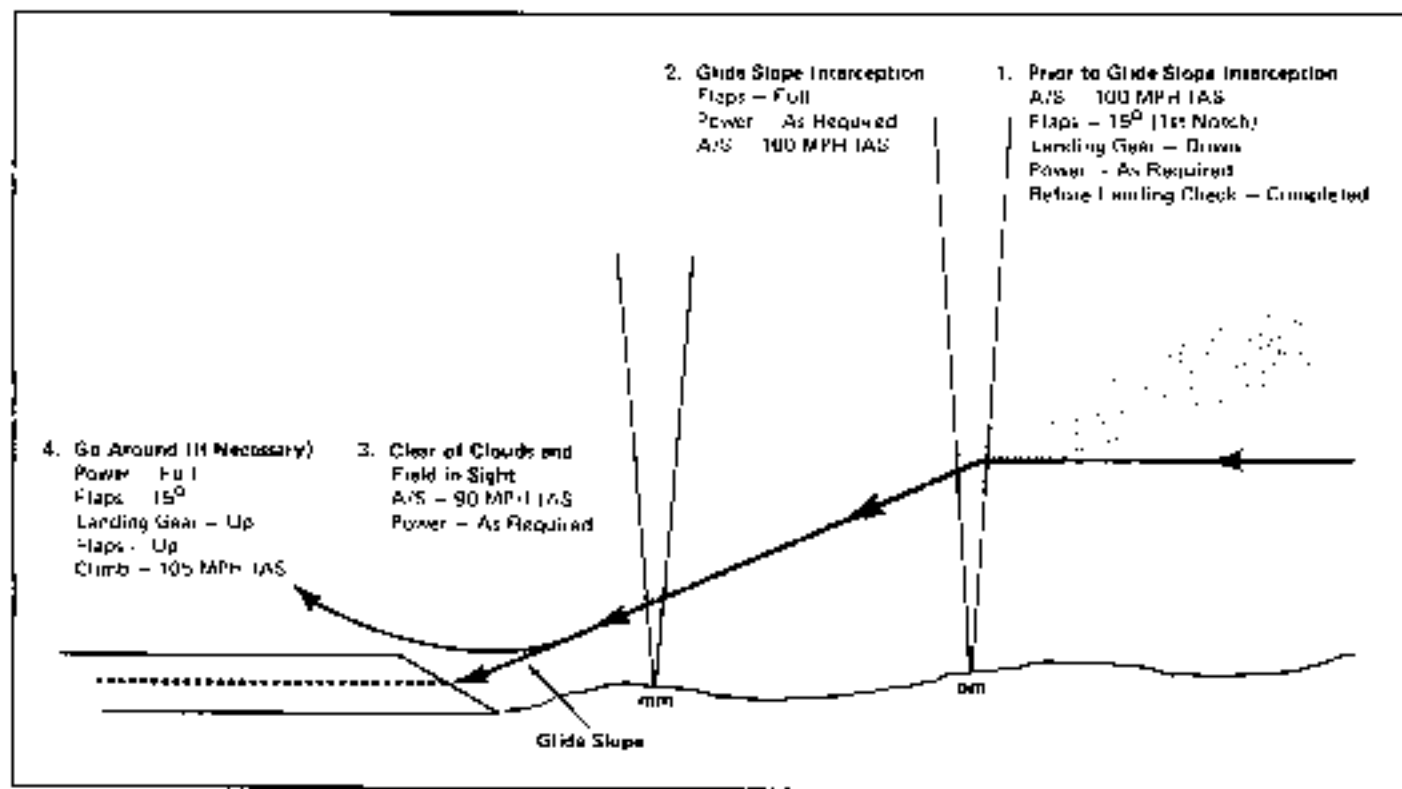

Figure 8-3 ILS Approach

## ICE AND RAIN

The possibility of engine or airframe icing is often present. If icing conditions are encountered, remember these two serious aspects: first, engine or carburetor ice may seriously affect engine operation. Second, an accumulation of airframe ice destroys lift and increases drag and weight resulting in abnormally high stalling speeds. Structural damage also may result due to vibrations induced by unbalanced loads of ice accumulations.

**NOTE:** Heavy airframe ice accumulations can greatly increase stalling speed. Extreme caution must be exercised when making approaches and landings and airspeed should be substantially increased under such conditions.

Installations on the aircraft for combating the various icing problems are pitot heat, carburetor heat, and cockpit heat. Entering anything other than very light icing conditions is exceptionally hazardous since light or trace icing can very rapidly change to moderate or heavy icing. If icing conditions are encountered, attempt to get out of the icing area as rapidly as possible.

**NOTE:** Ice accumulation on the propeller usually results in heavy vibration. It can sometimes be broken off by rapidly increasing and decreasing the propeller rpm.

Ice and snow accumulated on the aircraft while on the ground can also result in serious aerodynamic and structural effects when flight is attempted, especially during takeoff and climb-out. These hazards can be eliminated by removing snow and ice from the wings, fuselage, and empennage before flight is attempted. Flight in moderate or heavy rain should be avoided because of the probability of rain erosion damage to the leading edge of the propeller. After a flight in any type of rain the propeller should be inspected thoroughly for damage and either repaired as necessary or replaced.

## TURBULENCE AND THUNDERSTORMS

**CAUTION:** Flight in heavy turbulence or thunderstorms should be avoided if at all possible to eliminate the hazard of aircraft damage and loss of control.

Under night or instrument flight conditions, avoiding turbulent areas may be difficult. The following techniques are recommended for flight into turbulence or thunderstorms: (Throttle setting and altitude are the keys to flight in turbulent conditions.) When turbulence is encountered, the aircraft should be slowed to maneuvering speed (145 mph IAS) and kept at or below this speed while in turbulent conditions. All loose equipment in the aircraft should be secured, safety belt and shoulder harness tightened, and instrument lighting turned up full to minimize blinding caused by lightning.

**CAUTION:** When operating in turbulent conditions, avoid abrupt control inputs and unnecessary maneuvering. These actions may impose severe loads in turbulent conditions.

## NIGHT FLIGHT

When flying at night, thoroughly check all lighting systems and be familiar with the location of all switches in the cockpit during the preflight stage. Always carry a flashlight. Night flying may pose the

same problems as instrument flight and should be treated accordingly.

**NOTE:** When making night VFR takeoffs in areas of limited horizon references, the instrument takeoff procedures are recommended to avoid disorientation.

## COLD WEATHER OPERATION

The success of low temperature operation depends primarily upon the preparations made during the post-flight and ground handling of the aircraft in anticipation of the following day's operation. To expedite preflight inspection and ensure satisfactory operation for the next flight, the normal operating procedures outlined in Section 2 should be adhered to with the following additions and exceptions:

### Before Entering the Aircraft

Remove all protective covers and check to see that the airframe is free of ice, snow, and frost. Check all fuel drains for free flow, and battery for proper installation, if it was removed after the last flight.

### On Entering the Aircraft

Check flight controls for complete freedom of movement and complete other normal procedures.

### Starting Engine

The normal engine starting procedures should be used with the possible exception of using the choke. Use the choke steadily until the engine starts firing, then intermittently to keep the engine running if required. Cold starts may require a more retarded throttle setting.

**NOTE:** Moisture forms quickly on spark plugs during cold weather starts and can cause plug misfiring.

### Taxiing

Do not taxi through water or slush if it can be avoided. Water or slush splashed on wing and tail surfaces will freeze, increasing weight and drag and possibly limiting control surface movement. If taxiing behind other aircraft maintain a greater than normal interval to prevent ice and slush being blown on the aircraft from the aircraft ahead. Because of the small

tires and very low ground clearance of this aircraft it should never be operated from runways having more than one-inch accumulation of snow or slush.

### Before Takeoff

Run the engine up using carburetor heat to eliminate any possible induction system icing then return the carburetor heat control to the COLD position for takeoff.

### Takeoff

Make a normal takeoff using caution against possible icing. Carburetor heat should not be used during the takeoff roll.

**CAUTION:** Exercise caution in the application of brake steering on slick runways to avoid skidding and loss of directional control.

#### **After Takeoff—Climb**

If conditions require, apply carburetor heat as soon as full power is no longer required. If takeoff is made from a snow- or slush-covered field, operate the landing gear and flaps through several cycles to prevent their freezing in the retracted position.

**CAUTION:** Do not exceed the gear and flap operating limit airspeed during this operation.

#### **Landing**

Make a normal landing pattern and complete the normal checks and procedures. Use pitot heat as required.

**CAUTION:** Landing gear should be cycled prior to final approach and brakes checked to guard against freezing.

**WARNING:** Carburetor icing could be severe enough to demand its use in the traffic pattern. Do not use carburetor heat on final. Return the carburetor heat control to the COLD position when turning final.

As soon as the aircraft is firmly on the ground, retract the flaps and use brakes as little as possible on slippery runways.

#### **After Landing**

Use carburetor heat as required while taxiing. Exercise the same precautions in postflight taxiing operations as you would before flying.

#### **Before Leaving The Aircraft**

When use of the aircraft is planned later in the day or the following day, it should be hangared in a warm hangar if possible. If heated storage is not available, cover the aircraft to protect it against frost and snow.

### **HOT WEATHER AND DESERT OPERATION**

#### **Before Takeoff**

Check the aircraft thoroughly for dust and sand and clean such from any parts or operating mechanisms which it could damage.

**Takeoff**

Under extremely hot conditions a longer ground run will be required. Check takeoff and landing distance data in Appendix A. Performance of both aircraft and engine is dependent on the density altitude at which they operate.

**Before Leaving The Aircraft**

Leave the canopy slightly open when parking in the sun so the cockpit temperature will not become excessive.

**CAUTION:** High temperatures can cause fluid in the compass to boil away, dry out electrical insulation, and cause paint to pull away from the skin.

Whenever possible, protect all air inlets, vents, operating mechanisms, and cockpit from blowing dust and sand.

**NOTE:** Sand and dust in the air inlets and vents may restrict airflow during subsequent operations or cause engine damage.



## APPENDIX A—PERFORMANCE CHARTS AND GLOSSARY

A series of charts is provided on the following pages to furnish the pilot with sufficient data to make an intelligent and safe flight plan. The charts include data on takeoff, climb, landing, and operational data for cruising flight. Because the number of variables involved makes precise predictions impossible, the pilot should be alert to conditions which are not accounted for in the charts. No allowance has been made for navigational error, formation flight, fuel used during climb, or any number of other variables. Appropriate allowances for these items should be dictated by local requirements and should be accounted for when the fuel required for cruise is determined.

### GLOSSARY OF TERMS AND ABBREVIATIONS

The following terms may be found in this Appendix:

**IAS** — Indicated airspeed corrected for instrument error.

**CAS** — Calibrated airspeed; IAS corrected for installation error in the pitot-static system.

**TAS** — True airspeed: CAS corrected for density altitude.

**BHP** — Brake horsepower.

**RPM** — Engine revolutions per minute.

**Density Altitude** — The altitude in a standard atmosphere at which the density of the air is the same as the local air density.

### TEMPERATURE CONVERSION

A temperature conversion chart (Figure A-1) is included to facilitate conversion between Centigrade and Fahrenheit temperatures.

Figure A-1 Temperature Conversion Chart

CONVERSION METHOD:		°C = 5/9 (°F - 32)		°F = (9/5 °C) + 32	
40	40.0	+ 24.8	1 22	+ 71.6	1 48
38	38.4	-	7	26.8	23
36	36.4	-	3	37.4	29
34	34.0	-	0	32.0	26
32	32.0	-	0	77.0	55
30	30.0	-	30	86.0	63
28	28.0	-	28	82.4	59
26	26.0	-	14.8	37.4	29
24	24.0	-	11.2	30.2	24
22	22.0	-	30	86.0	63
20	20.0	-	31.4	89.5	95
18	18.0	-	36	96.8	118
16	16.0	-	105	221.0	235
14	14.0	-	100	212.0	225
12	12.0	-	104.4	209.8	220
10	10.0	-	118	230.0	240
8	8.0	-	119	239.8	245
6	6.0	-	120	248.0	250
4	4.0	-	125	257.0	255
2	2.0	-	129	266.0	260
0	0.0	-	135	275.0	265
-2	-2.0	-	140	284.0	270
-4	-4.0	-	145	293.0	275
-6	-6.0	-	150	292.0	280
-8	-8.0	-	155	291.0	285
-10	-10.0	-	160	290.0	290
-12	-12.0	-	165	289.0	295
-14	-14.0	-	170	288.0	300
-16	-16.0	-	175	287.0	305
-18	-18.0	-	180	286.0	310
-20	-20.0	-	185	285.0	315
-22	-22.0	-	190	284.0	320
-24	-24.0	-	195	283.0	325
-26	-26.0	-	200	282.0	330
-28	-28.0	-	205	281.0	335
-30	-30.0	-	210	280.0	340
-32	-32.0	-	215	279.0	345
-34	-34.0	-	220	278.0	350
-36	-36.0	-	225	277.0	355
-38	-38.0	-	230	276.0	360
-40	-40.0	-	235	275.0	365
40	40.0	+ 24.8	1 22	+ 71.6	1 48
38	38.4	-	7	26.8	23
36	36.4	-	3	37.4	29
34	34.0	-	0	32.0	26
32	32.0	-	0	77.0	55
30	30.0	-	30	86.0	63
28	28.0	-	28	82.4	59
26	26.0	-	14.8	37.4	29
24	24.0	-	11.2	30.2	24
22	22.0	-	30	86.0	63
20	20.0	-	31.4	89.5	95
18	18.0	-	36	96.8	118
16	16.0	-	105	221.0	235
14	14.0	-	100	212.0	225
12	12.0	-	104.4	209.8	220
10	10.0	-	118	230.0	240
8	8.0	-	119	239.8	245
6	6.0	-	120	248.0	250
4	4.0	-	125	257.0	255
2	2.0	-	129	266.0	260
0	0.0	-	135	275.0	265
-2	-2.0	-	140	284.0	270
-4	-4.0	-	145	293.0	275
-6	-6.0	-	150	292.0	280
-8	-8.0	-	155	291.0	285
-10	-10.0	-	160	290.0	290
-12	-12.0	-	165	289.0	295
-14	-14.0	-	170	288.0	300
-16	-16.0	-	175	287.0	305
-18	-18.0	-	180	286.0	310
-20	-20.0	-	185	285.0	315
-22	-22.0	-	190	284.0	320
-24	-24.0	-	195	283.0	325
-26	-26.0	-	200	282.0	330
-28	-28.0	-	205	281.0	335
-30	-30.0	-	210	280.0	340
-32	-32.0	-	215	279.0	345
-34	-34.0	-	220	278.0	350
-36	-36.0	-	225	277.0	355
-38	-38.0	-	230	276.0	360
-40	-40.0	-	235	275.0	365
40	40.0	+ 24.8	1 22	+ 71.6	1 48
38	38.4	-	7	26.8	23
36	36.4	-	3	37.4	29
34	34.0	-	0	32.0	26
32	32.0	-	0	77.0	55
30	30.0	-	30	86.0	63
28	28.0	-	28	82.4	59
26	26.0	-	14.8	37.4	29
24	24.0	-	11.2	30.2	24
22	22.0	-	30	86.0	63
20	20.0	-	31.4	89.5	95
18	18.0	-	36	96.8	118
16	16.0	-	105	221.0	235
14	14.0	-	100	212.0	225
12	12.0	-	104.4	209.8	220
10	10.0	-	118	230.0	240
8	8.0	-	119	239.8	245
6	6.0	-	120	248.0	250
4	4.0	-	125	257.0	255
2	2.0	-	129	266.0	260
0	0.0	-	135	275.0	265
-2	-2.0	-	140	284.0	270
-4	-4.0	-	145	293.0	275
-6	-6.0	-	150	292.0	280
-8	-8.0	-	155	291.0	285
-10	-10.0	-	160	290.0	290
-12	-12.0	-	165	289.0	295
-14	-14.0	-	170	288.0	300
-16	-16.0	-	175	287.0	305
-18	-18.0	-	180	286.0	310
-20	-20.0	-	185	285.0	315
-22	-22.0	-	190	284.0	320
-24	-24.0	-	195	283.0	325
-26	-26.0	-	200	282.0	330
-28	-28.0	-	205	281.0	335
-30	-30.0	-	210	280.0	340
-32	-32.0	-	215	279.0	345
-34	-34.0	-	220	278.0	350
-36	-36.0	-	225	277.0	355
-38	-38.0	-	230	276.0	360
-40	-40.0	-	235	275.0	365
40	40.0	+ 24.8	1 22	+ 71.6	1 48
38	38.4	-	7	26.8	23
36	36.4	-	3	37.4	29
34	34.0	-	0	32.0	26
32	32.0	-	0	77.0	55
30	30.0	-	30	86.0	63
28	28.0	-	28	82.4	59
26	26.0	-	14.8	37.4	29
24	24.0	-	11.2	30.2	24
22	22.0	-	30	86.0	63
20	20.0	-	31.4	89.5	95
18	18.0	-	36	96.8	118
16	16.0	-	105	221.0	235
14	14.0	-	100	212.0	225
12	12.0	-	104.4	209.8	220
10	10.0	-	118	230.0	240
8	8.0	-	119	239.8	245
6	6.0	-	120	248.0	250
4	4.0	-	125	257.0	255
2	2.0	-	129	266.0	260
0	0.0	-	135	275.0	265
-2	-2.0	-	140	284.0	270
-4	-4.0	-	145	293.0	275
-6	-6.0	-	150	292.0	280
-8	-8.0	-	155	291.0	285
-10	-10.0	-	160	290.0	290
-12	-12.0	-	165	289.0	295
-14	-14.0	-	170	288.0	300
-16	-16.0	-	175	287.0	305
-18	-18.0	-	180	286.0	310
-20	-20.0	-	185	285.0	315
-22	-22.0	-	190	284.0	320
-24	-24.0	-	195	283.0	325
-26	-26.0	-	200	282.0	330
-28	-28.0	-	205	281.0	335
-30	-30.0	-	210	280.0	340
-32	-32.0	-	215	279.0	345
-34	-34.0	-	220	278.0	350
-36	-36.0	-	225	277.0	355
-38	-38.0	-	230	276.0	360
-40	-40.0	-	235	275.0	365

## DENSITY ALTITUDE CHART

A Density Altitude Chart (Figure A-2) is provided to determine the density altitude for a known free air temperature and pressure altitude. Many of the performance charts are based on density altitude rather than pressure altitude to allow for temperature compensation. At the right side of the chart, a conversion factor (reciprocal square root of the density ratio) is given to provide a means of computing true airspeed from indicated airspeed at a known density altitude. For example, at an IAS of 180 mph and a density altitude of 4000 feet, the TAS is  $180 \times 1.061 = 191$  mph TAS.

### NOTE:

To obtain the pressure altitude, set 29.92 in the aircraft altimeter setting window, and read the pressure altitude directly. Another method is to compute the difference in pressure between the local altimeter setting and 29.92. Multiply this difference by 1000 to obtain feet. If the local altimeter setting is above 29.92, subtract the computed feet from the local elevation to obtain pressure altitude. If the local altimeter setting is below 29.92, add the value to the local elevation.

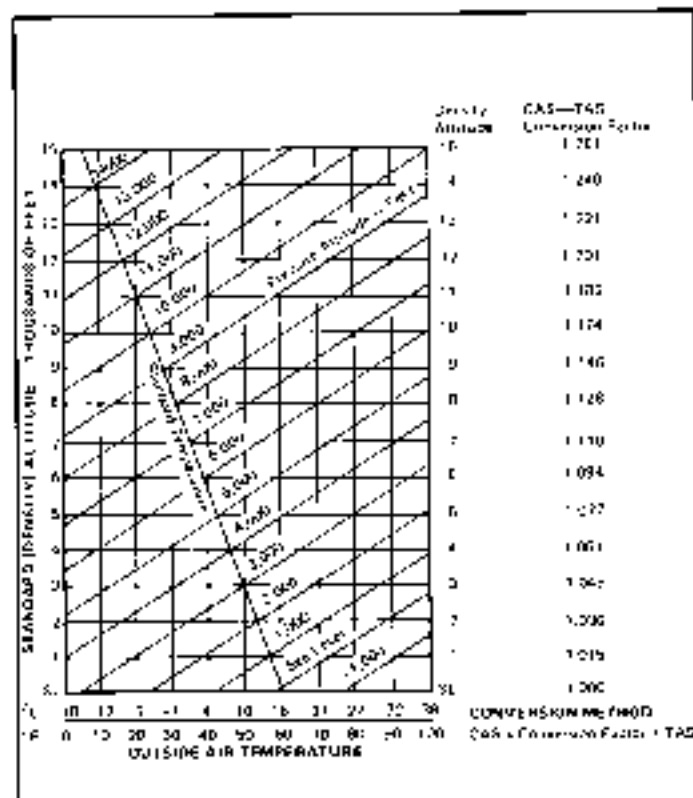
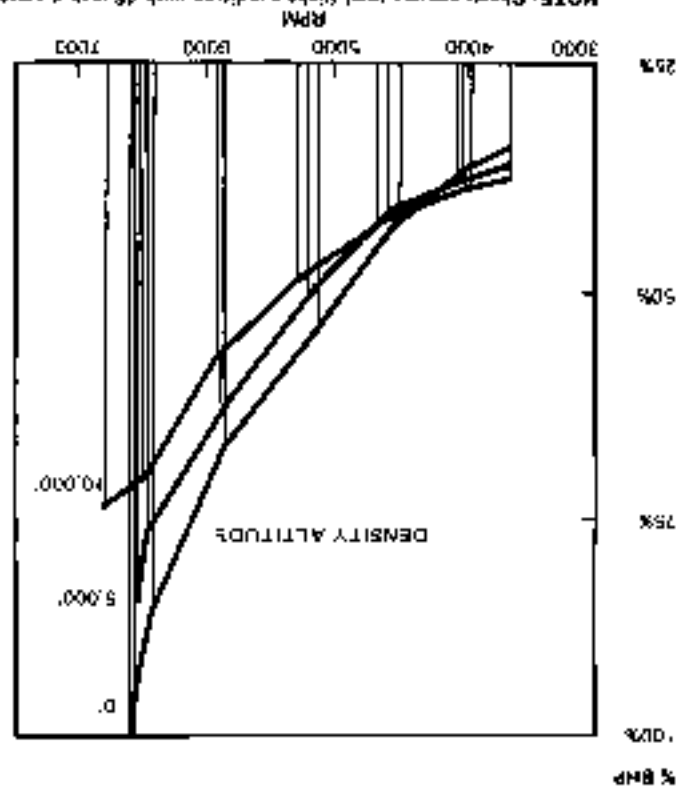
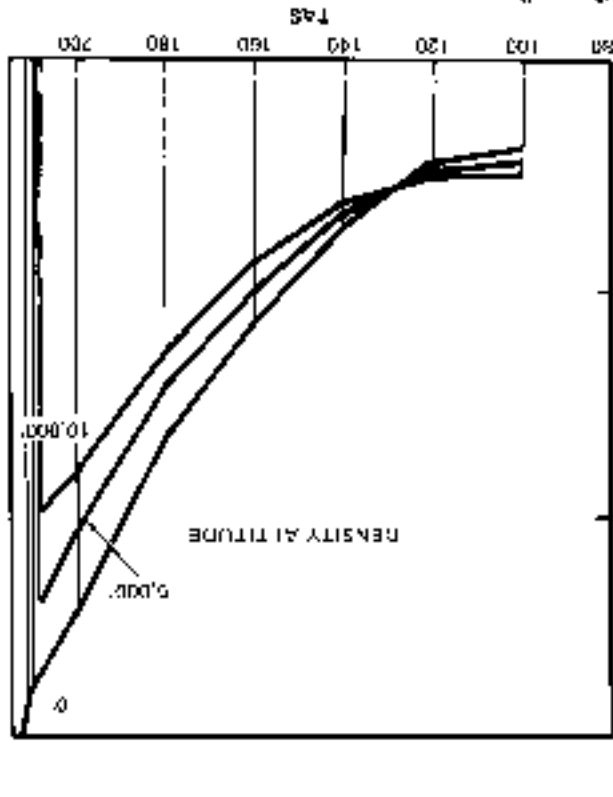

Figure A.2 Density Altitude Chart



NOTE: Charts assume level flight condition with 46-inch diameter/93 inch pitch propeller.

Figure A-3 Speed Power Charts

## SPEED/POWER CHARTS

For any selected BHP, the power curve (Figure A-3) will define the rpm to achieve that power at the designated altitude. The maximum BHP percent for cruising flight is 75 percent. The Speed Curve will show a TAS to expect at various BHP's and density altitudes.

## FUEL FLOW

Fuel flow corresponding to any selected brake horsepower may be determined by reference to the fuel flow chart (Figure A-4).

## TAKEOFF DISTANCE

The takeoff distance chart (Figure A-5) predicts total distance required to clear a 50-foot obstacle when density altitude and takeoff weight are known. The chart assumes a hard surface with no incline and no wind.

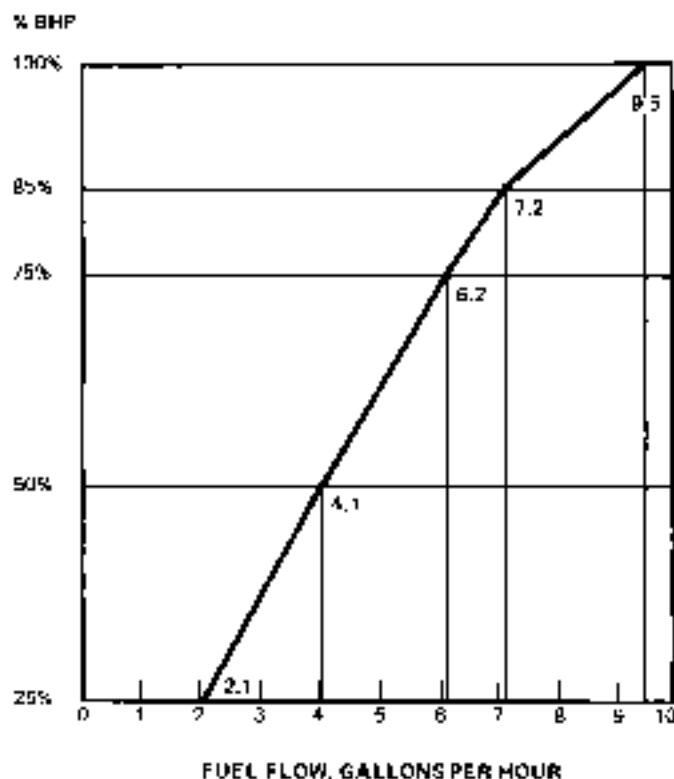

Figure A-4 Fuel Flow Chart

GROSS WEIGHT,  
POUNDS

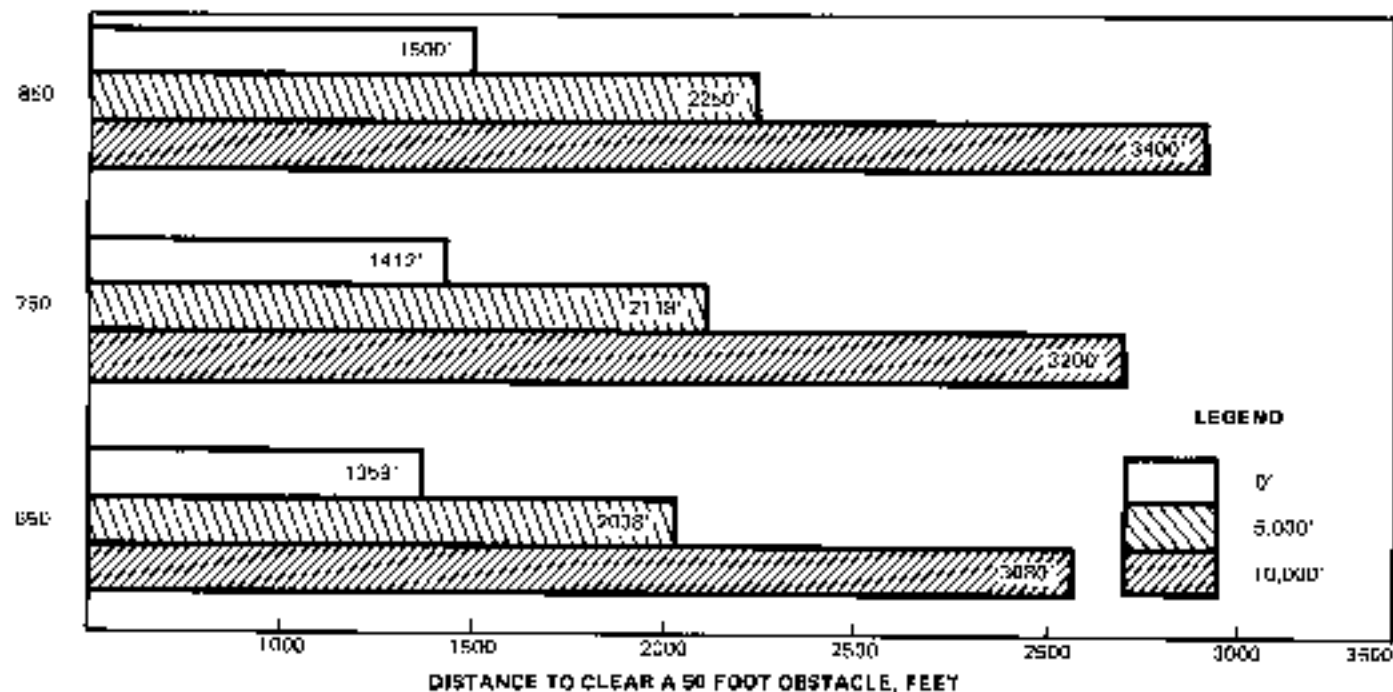

Figure A-5 Takeoff Distance Chart

RATE OF CLIMB,  
FEET PER MIN.

80 5G AT GROSS WEIGHT, 850 LBS

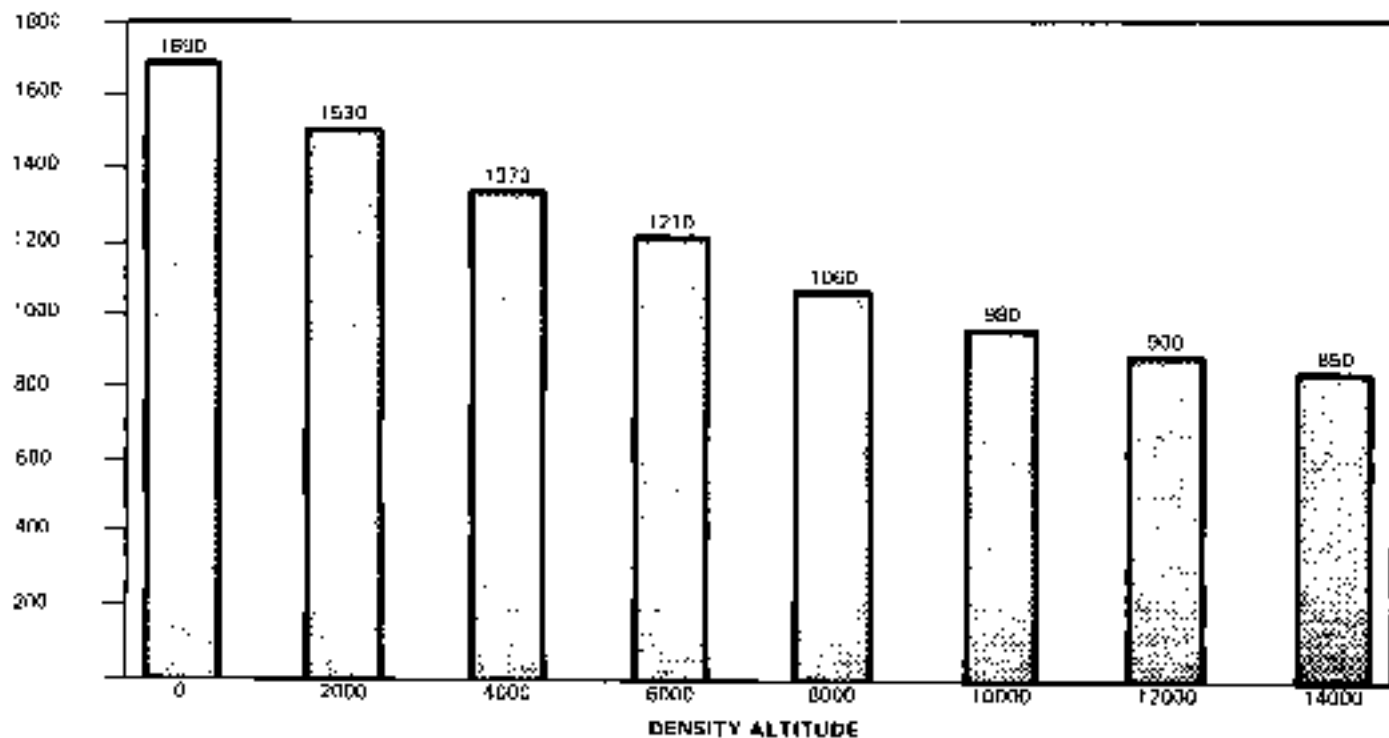

Figure A-8 Rate of Climb Chart

## RATE OF CLIMB

The Rate of Climb Chart (Figure A-6) shows the rate of climb to be expected at gross weight under various density altitude conditions.

## ENDURANCE

The endurance chart (Figure A-7) provides flight/time versus BHP information. No allowances are made for taxi, takeoff, or climb.

## RANGE

The range chart shows range versus BHP information (Figure A-8). The chart assumes that 28 gallons of fuel are consumed in level flight. For a smaller amount of fuel, reduce the range proportionately to the percentage of 28 gallons used. No allowances are made for taxi, takeoff, or climb.

## LANDING DISTANCE

The landing distance chart (Figure A-9) is provided for computing the landing distance over a 50-foot obstacle when moderate braking is used. The landing distance chart assumes a hard surface runway, 100-percent flaps, no runway incline, and no wind.

## STALL SPEEDS

The stall speed chart (Figure A-10) depicts the relationship of stall speed to angle of bank (and g-level) for various flap settings. Note that the chart is good only at sustained altitude or at the indicated g level. This chart assumes gross weight condition of 850 pounds, and a CAW airfoil. Deviations from prescribed rigging and airfoil sections will result in different stall speeds.

For the most accurate and consistent indication of the aircraft's margin over stall, equip the aircraft with an angle-of-attack indicator. This instrument will automatically compensate for variations in weight, airfoil section, g-level, and angle of bank, thereby providing extremely valuable information during all flight conditions.



TIME REQUIRED TO CONSUME 29 GAL. FUEL

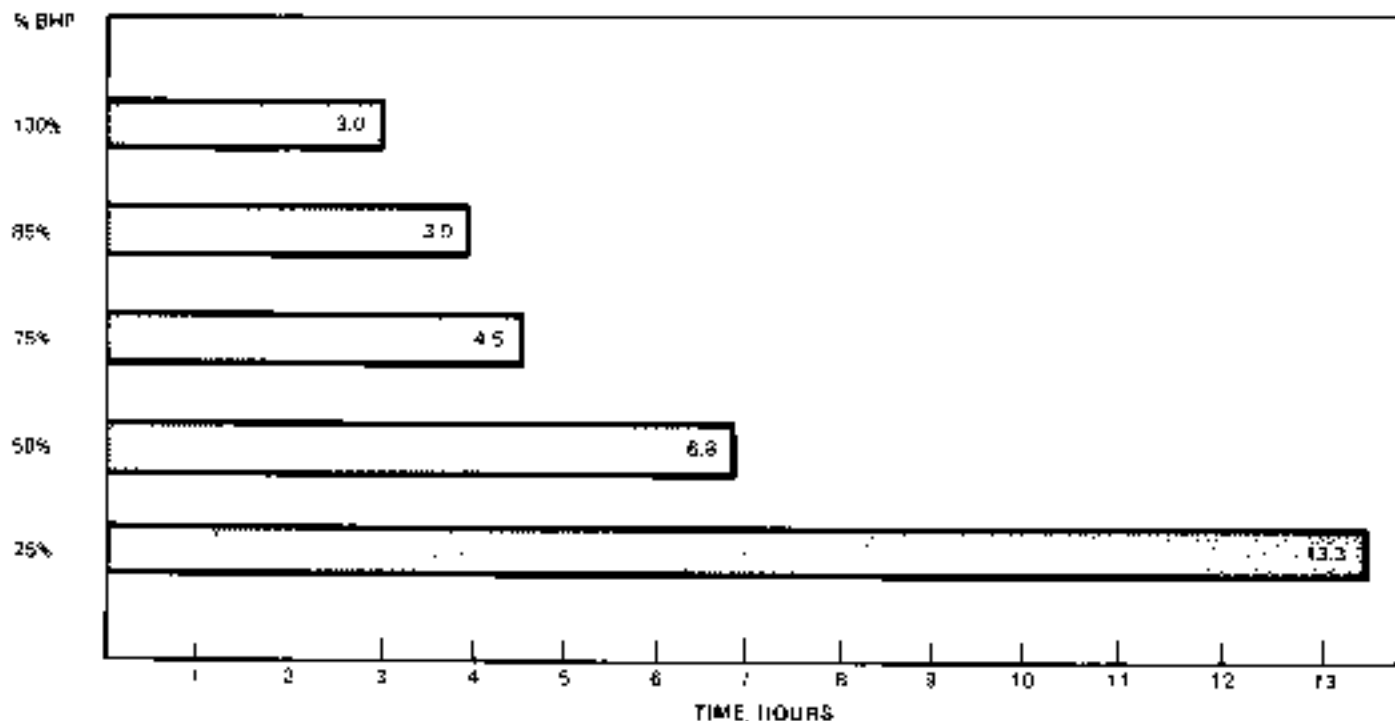

NOTE: No allowance has been made for taxi, take-off, or climb.

Figure A-7 Endurance Chart

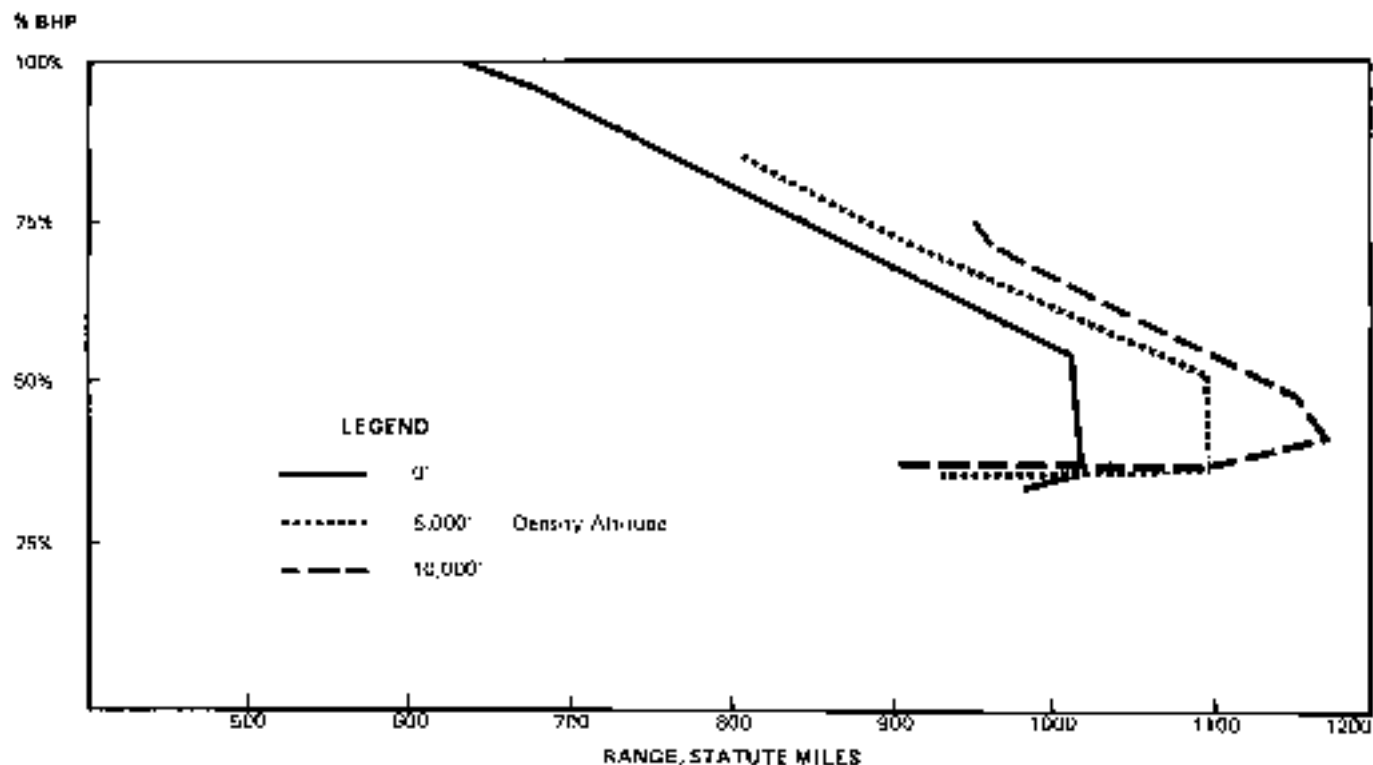

NOTE: No allowance has been made for taxi, takeoff or climb.

Figure A-8 Range Chart

GROSS WEIGHT  
POUNDS

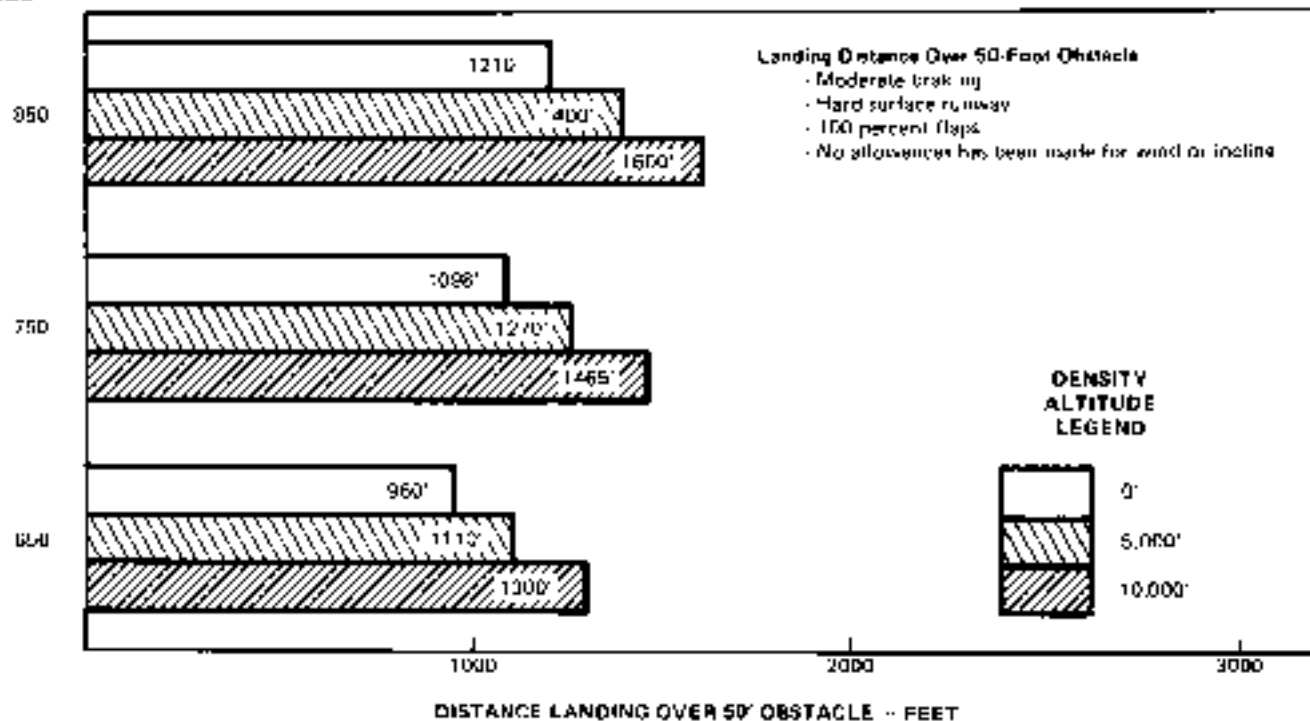

Figure A-9 Landing Distance Chart

Figure A-10 Stall Speeds Chart

		ANGLE OF BANK		
		0°	45°	60°
100% FLAPS	AIRCRAFT IS LIMITED TO 20° FLAPS EXTENDED	10	14	20
		154	20	28
50% FLAPS	AIRCRAFT IS LIMITED TO 20° FLAPS EXTENDED	19	30	42
		154	20	28
0 FLAPS	AIRCRAFT IS LIMITED TO 20° FLAPS EXTENDED	29	45	60
		166	22	30
		80	90	105
		80	90	105

## APPENDIX B INITIAL CHECKOUT

---

Perhaps the most difficult part of preparing for a first flight in the BD-5 will be to overcome the erroneous and completely unfounded feeling that the airplane will be tricky to handle and hard to fly because of its small size and high speed capability. In truth, the BD-5 is a very stable, gentle, and easily controllable aircraft that can be flown safely by any proficient pilot, given an adequate checkout. The term "adequate checkout" is the key to a successful and enjoyable first flight for any pilot.

To begin with, the pilot should be thoroughly familiar with the aircraft, the engine, all systems, normal operating procedures, emergency procedures and operating limitations. He should have read and understood the entire owner's handbook, with emphasis on engine characteristics and operation. Some important engine operating experience will have been gained during the break-in period described in Section 7, and more will be gained during the taxi tests. Cockpit familiarization should be thorough enough that the pilot can locate every switch and control the first try with his eyes closed. Systems

checkout should include lifting the aircraft off the ground on sawhorses, sitting in the cockpit and retracting and extending the landing gear with the left hand until there is no movement of the right arm or hand on the sidestick. Flap operation should also be practiced with simulated airloads by having one person pull up on each flap trailing edge with a force of 10 pounds while the flaps are being put down. During all the cockpit familiarization and all the initial testing, the pilot should use the same seat position and should wear all the equipment he plans to use on the first flight. It is highly recommended that both a parachute and protective helmet be worn until the airspeed/load factor envelope expansion flight tests have been completed and the pilot is familiar with all the flight characteristics. During the cockpit checkout, the aircraft should be tipped back on the tailskid with the pilot in the cockpit so he can see at what nose attitude the tail hits the ground. Takeoff attitude should also be simulated by raising the nosewheel six inches off the ground.

Once the pilot has a comprehensive knowledge of the aircraft and its systems, flight manual procedures, cockpit layout, and engine operating characteristics, he is ready to begin low speed taxiing.

The objective of the low speed taxiing practice is to acquaint the pilot with the aircraft's handling characteristics on the ground below the speed at which he has aerodynamic control. These initial tests should be conducted with a wind velocity less than 10 mph, with little or no crosswind. The first aircraft motion should be straight ahead, very slowly, with several stops to test the brakes and to practice braking symmetrically. Gentle turns should be tried next, and then tighter ones until the pilot is able to pivot the aircraft around at constant speed with the inside wheel rolling just slightly. In general, the tighter the turn, the more power required to maintain taxi speed. When using brakes for sharp turns it is better to depress the rudder pedal fully instead of trying to hold the opposite pedal in a neutral position. When the pilot feels he has complete control of the aircraft and feels at ease, he may begin high speed taxiing.

The purpose of the high speed taxi tests is to develop the ability to track straight ahead at higher speeds and to become familiar with the stick forces and technique required during rotation and tracking with the nosewheel off the runway. High-speed taxiing gives the pilot his first look at aerodynamic control of the aircraft. At speeds above 30 mph, both the ailerons and rudder will be effective and at 40 mph it is possible to maintain directional control with the rudder alone. The elevator becomes effective enough to lift the nosewheel off at about 55 mph power-on and 40 mph at idle. To use the minimum amount of runway, and to simulate a takeoff, full throttle should be applied after lineup, held until the desired airspeed is reached, and then retarded to idle. During initial attempts at rotation, care should be taken not to hit the tail of the aircraft. It's better to use too little stick force at first and work up to nosewheel lift-off rather than start out with too much stabilator and hit the tail. All high-speed, taxi tests should be done with the flaps up or down and airspeed less than 60 mph to prevent an inadvertent lift-off.

Once the pilot is proficient at high-speed taxiing he will have developed the ability to handle the aircraft during all phases of both the takeoff and landing roll, and should be prepared for short flights down the runway.

Before the first flight of the BD-5, or of any experimental aircraft, at least one, (and preferably more) lift-offs and low level flights down the runway should be made. These flights are very important since they allow the pilot/builder to determine if the trim in any axis is grossly out of adjustment, that the flight controls operate in the correct direction without binding with lift on the wings, that there are no control or aeroelastic problems up to a speed greater than that to be used during climb and that the engine operates within temperature limits with no unusual vibrations at full throttle and climb speed.

The first lift-off should be accomplished just like the high speed taxi, except that full flaps should be used, and the aircraft should be allowed to accelerate to 70 mph, at which time the throttle should be retarded to idle and the nose raised to lift-off attitude. As the aircraft lifts off, the nose will have to be lowered just slightly to prevent ballooning. A con-

stant altitude of approximately one foot (wheel height) should be maintained, increasing angle of attack as required until the same attitude used for takeoff is reached. The pilot should then hold this attitude constant and allow the aircraft to settle onto the main gear, hold the nosewheel off until the air-speed has decreased to 40 mph, lower the nose gently and use moderate braking to stop. Total runway required for this type of lift-off will be approximately 2500 feet. When this maneuver can be performed proficiently, a power-on, full-flaps, lift-off should be tried.

In this maneuver, full power is applied as before, the nose is rotated to lift-off attitude at 55-60 mph, and the aircraft is flown off the runway with full throttle. After leveling off at 1 to 2 feet and upon reaching 80 mph IAS, the power should be reduced to idle. A power reduction when airborne causes a nose-up trim change, so some forward stick pressure will be required as the throttle is retarded. Use the same landing technique as before. This power-on lift-off to 80 mph and the landing will require approximately 3500 feet of runway.

The power-on lift-offs should be continued until at least 100 mph IAS is reached. During these flights down the runway the pilot should be especially alert to any out-of-trim condition, unusual noise or vibration, or binding in the control system. All malfunctions should be repaired before going on to the next higher airspeed. Enough fuel should be carried on these flights down the runway to make a go-around if necessary. About three gallons of fuel in each wing should be sufficient. Approximately 6000 feet of runway will be required for a lift-off, acceleration to 100 mph IAS, deceleration to touchdown speed, and the landing roll.

Once these series of lift-offs have been successfully completed, both the aircraft and the pilot should be ready for the first flight away from the runway.

The optimum weather conditions for first flight are a calm wind and no turbulence with at least a 5000 foot ceiling and 10 miles visibility. It is possible, of course, to make the first flight in far worse conditions but it should be noted that the first several flights are training flights for the pilot as much as they are

test flights on the aircraft, and it is nearly impossible to learn anything about the flying qualities of an aircraft if the air is rough.

The takeoff roll and lift-off will already be familiar maneuvers and the first difference between the lift-offs and the first flight will be the gear and flap retraction. Once the aircraft is airborne, allow it to climb and accelerate until both 80 mph IAS and 20 feet AGL are reached. Since there is both a trim change and a tendency to push on the stick during gear retraction, a reasonable ground clearance is desirable during this slight but inevitable pitch oscillation. If the gear does not come all the way up on the first try, put it in the full down and locked position before attempting the second retraction. It is much more difficult to retract the gear from an intermediate position. Once the gear is up and locked, the flaps can be fully retracted. Bringing the flap handle full forward in about three seconds minimizes the abruptness of the trim change and allows the aircraft to continue acceleration without settling. When the airspeed reaches 100 mph, raise the nose slightly to maintain a normal climb speed of 105 mph.



As soon as 400 feet AGL is reached, begin a turn to downwind leg, in order to reach a low key position (1000 ft. AGL, opposite the approach end of the runway) as quickly as possible. Don't level off at pattern altitude but continue climbing until a turn back to the end of the runway would put the aircraft at high key position (1500 ft. AGL directly over the approach end of the runway). Continue climbing in a racetrack pattern directly over the airport, always keeping either high or low key position within gliding distance, until 5000 feet AGL is reached. This altitude allows a reasonable range from the airport and is plenty high for stalls and maneuvering.

Level off at 5000 feet AGL and leave the throttle full forward until the airspeed is 140 to 150 mph IAS. Throttle back to maintain this speed and then spend about 15 minutes doing turns, 30 degree bank-to-bank rolls, lazy 8's, etc., to get the feel of the aircraft. Try a few steep turns (2g, 60 degree bank) and learn to roll in and out at constant altitude. Slow down to 80 mph (gear and flaps up) and try a few turns in slow flight. Retard the throttle to 4000 rpm and do an approach to a stall, recovering at the first indication of buffet and noting the airspeed. Do this a

couple of times until you have a good feel for the approaching stall, and then continue to increase back stick pressure through the buffet until the lateral roll-off occurs; recover by relaxing back pressure, and adding power.

Stabilize and trim at 100 mph IAS and cycle the landing gear up and down about three times, getting used to the trim change so there is no pitch oscillation upon extension or retraction of the gear. Leave the landing gear down and lower the flaps to half, and then full, noting the trim and attitude change. With the gear and flaps down, do a couple of stall approaches to buffet and then continue to either the roll-off or until full aft stick is reached. Recover from the stall, retract the gear and flaps and accelerate back up to 100 mph IAS. Return to the airport, descending as required to arrive at high key at 100 mph IAS and idle power. Use a medium banked 30 degree gliding turn to downwind and lower the landing gear. Put down half flaps at low key and make a gliding turn to base leg, slowing to 90 mph IAS. Lower full flaps on base leg and maintain 90 mph until crossing the runway threshold. Begin the flare at about 10 feet, remembering that the tendency

is to flare high because of the low ground clearance of the aircraft. It generally takes about five landings before one can consistently make good touchdowns.

After the first flight and the next three or four flights, all doors and access panels should be removed and the aircraft inspected carefully for damage, misalignment, or loose objects.

On each succeeding flight, the airspeed and g-load should be increased in small increments (10 to 20 mph +1 g per flight) until the redline airspeed and limit load factor have been reached. There should be no unusual vibration, noise or control system or flying qualities problems at any point within the flight envelope. All systems should have been operated throughout their limits and at least one flight with full fuel made (including switching tanks) before the aircraft is flown out of gliding distance of the runway.

After about five flights in the BD-5, everything will have become familiar and one can relax and begin to enjoy the excellent flying qualities and maneuverability of the aircraft. At this stage most pilots will feel that this is the easiest airplane they have ever

flown and can't understand how anyone could have any problems with it. The BD-5 is very easy to fly and the only difficulty is adjusting to its unique size, novel design features, and its deceptively high speed. The first time an overwhelming urge for a "buzz job" comes over you, think it over for a few minutes, and then don't do it. Remember at 230 mph IAS you will be traveling the length of a football field in less than one second, and your radius of turn or pullup at 2 g will be almost a half mile!

Another good general rule for longevity in flying the BD-5 or any other experimental aircraft is: never do anything at low altitude you haven't already done several times at high altitude with a parachute on. Treat the aircraft with respect and enjoy a long and illustrious flying career. Happy Landings!

NOTES:

