



***MC***  
**LSA**

**SERIAL NUMBER: \_\_\_\_\_**

## **Aircraft Operating Instructions (AOI)**

THIS DOCUMENT AND THE TECHNICAL DATA HEREON DISCLOSED ARE PROPRIETARY TO FLIGHT DESIGN AND SHALL NOT BE USED, RELEASED, OR DISCLOSED IN WHOLE OR IN PART WITHOUT EXPRESS WRITTEN PERMISSION FROM FLIGHT DESIGN



# Aircraft Operating Instructions (AOI)

Type: *MC*

Series: *MC*-LSA

Page: ii

## RECORD OF MANUAL REVISIONS

Rev	Pages	Date	Chapter	completed
00	all	10 July 2009	New Document	Oleksandr Kozyriev

AA 04300001

Revision No. 00

Date: 10 July 2009



# Aircraft Operating Instructions (AOI)

Type: *MC*

Series: *MC*-LSA

Page: iii

## TABLE OF CONTENTS

<b>INTRODUCTION</b> .....	<b>V</b>
<b>1. GENERAL INFORMATION</b> .....	<b>1-1</b>
1.1. MANUFACTURER: .....	1-1
1.2. IN THE USA CONTACT.....	1-1
1.3. CONTINUED AIRWORTHINESS INSTRUCTIONS.....	1-2
1.4. MAIN DIMENSIONS:.....	1-4
1.5. ENGINE.....	1-6
1.6. PROPELLER.....	1-6
1.7. MINIMUM EQUIPMENT.....	1-7
1.8. RECOMMENDED ADDITIONAL EQUIPMENT.....	1-7
<b>2. LIMITATIONS</b> .....	<b>2-1</b>
2.1. AIRSPEED LIMITATIONS.....	2-1
2.2. FLIGHT LOAD FACTOR LIMITS.....	2-2
2.3. TIRE PRESSURE .....	2-2
2.4. MASS AND CENTER OF GRAVITY LIMITS:.....	2-2
2.5. POWER PLANT LIMITATIONS.....	2-3
2.6. OTHER LIMITATIONS.....	2-4
<b>3. EMERGENCY PROCEDURES</b> .....	<b>3-1</b>
3.1. EMERGENCY PROCEDURES CHECKLISTS .....	3-1
3.2. STALLS .....	3-3
3.3. INADVERTENT SPIN .....	3-3
3.4. EMERGENCY LANDING .....	3-4
3.5. AFTER OVERTURN ON LANDING .....	3-5
3.6. DEPLOYING THE BALLISTIC RECOVERY SYSTEM.....	3-6
3.7. ENGINE FAILURE .....	3-7
3.8. CARBURETOR OR ENGINE FIRE.....	3-8
3.9. LOSS OF COOLANT .....	3-9
3.10. LOSS OF OIL .....	3-9
3.11. FAILURE OF FLAP CONTROL.....	3-10
3.12. DYNON EMS FAILURE (IF INSTALLED) .....	3-10
<b>4. NORMAL PROCEDURES</b> .....	<b>4-1</b>
4.1. NORMAL PROCEDURES CHECKLISTS .....	4-1
4.2. PREFLIGHT INSPECTION.....	4-6
4.3. PASSENGER BRIEFING .....	4-7
4.4. STARTING THE ENGINE.....	4-8
4.5. AUTOPILOT OPERATION .....	4-8
4.6. BEFORE TAKE-OFF .....	4-9
4.7. TYPICAL PATTERN .....	4-9
4.8. TAKE-OFF AND CLIMB.....	4-12
4.9. CRUISE.....	4-14
4.10. TURNS.....	4-15
4.11. STALL .....	4-16
4.12. APPROACH AND LANDING .....	4-16
4.13. SHUTTING DOWN THE ENGINE .....	4-18
4.14. CHECKING THE EMERGENCY LOCATION TRANSMITTER (ELT) .....	4-18



# Aircraft Operating Instructions (AOI)

Type: *MC*

Series: *MC*-LSA

Page: iv

<b>5. PERFORMANCE.....</b>	<b>5-1</b>
5.1. PERFORMANCE DATA FOR MTOW @ 600 KG (1320 LBS).....	5-1
5.2. FLIGHT ALTITUDE AND DENSITY ALTITUDE .....	5-2
5.3. SIGNIFICANCE OF THE WIND COMPONENT .....	5-4
5.4. ENGINE PERFORMANCE SUBJECT TO ALTITUDE .....	5-6
5.5. CALCULATING THE TAKE-OFF DISTANCE.....	5-6
5.6. CALCULATING CLIMB PERFORMANCE .....	5-10
5.7. GLIDING CHARACTERISTICS.....	5-11
<b>6. WEIGHT AND BALANCE, AND EQUIPMENT LIST .....</b>	<b>6-1</b>
6.1. WEIGHT LIMITS .....	6-1
6.2. WEIGHING .....	6-1
6.3. FLIGHT MASS AND CENTER OF GRAVITY .....	6-5
6.4. EQUIPMENT.....	6-10
<b>7. DESCRIPTION OF AIRPLANE AND SYSTEMS.....</b>	<b>7-1</b>
7.1. AIRFRAME .....	7-1
7.2. SYSTEMS.....	7-3
7.3. FLIGHT CONTROLS .....	7-9
7.4. COCKPIT.....	7-14
7.5. PLACARDS AND MARKINGS .....	7-20
<b>8. HANDLING AND SERVICING .....</b>	<b>8-1</b>
8.1. JACKING .....	8-1
8.2. SECURING THE AIRCRAFT FOR ROAD TRANSPORTATION.....	8-2
8.3. PARACHUTE RECOVERY SYSTEM MAINTENANCE.....	8-2
8.4. CLEANING AND CARE .....	8-2
8.5. MANDATORY AIRCRAFT INSPECTIONS .....	8-3
8.6. REPAIRS TO THE AIRFRAME .....	8-4
8.7. CONTROL SURFACE DEFLECTIONS .....	8-5
<b>9. SUPPLEMENTS.....</b>	<b>9-1</b>
9.1. SAILPLANE TOW .....	9-1
9.2. BANNER TOW .....	9-1
<b>APPENDICES.....</b>	<b>1</b>
APPENDIX 1 – CURRENT WEIGHING REPORT .....	1
APPENDIX 2 – CURRENT EQUIPMENT LIST.....	2
APPENDIX 3 – SAFETY FLIGHT REPORT FORM .....	3
APPENDIX 4 - ELECTRICAL SYSTEM.....	4



## Aircraft Operating Instructions (AOI)

Type: *MC*

Series: *MC*-LSA

Page: v

### INTRODUCTION

Every pilot must familiarize him/herself with the specific characteristics of each Light Sport aircraft. This Aircraft Operating Instruction (AOI) must be studied in detail before the first flight is undertaken with the aircraft. The same rule applies to the operating handbooks and manuals of the ballistic recovery system, the engine and all other equipment installed in the aircraft, such as the Dynon EFIS/EMS, etc. All avionics and instruments recommendations following in this document are for reference only.

Engines of Light Sport aircraft are not Part 33 certified aviation engines. The flight route must thus be chosen to ensure that an emergency landing after engine failure can be undertaken without difficulty.

The MC may only be operated under visual flight rules (VFR). Based on national regulations operation under IFR, but in VMC, may be permissible based on the installed equipment to the individual aircraft. Due to the high cruise speed and the great range, pilots may encounter meteorologically critical weather conditions more often. Flying into IMC conditions without the necessary training is extremely dangerous. As the pilot in command, you are responsible for the safety of your passenger as well as for your own safety. You are also responsible for the safety of uninvolved third parties. Avoiding dangerous situations is a pilot's first duty.



## Aircraft Operating Instructions (AOI)

Type: *MC*

Series: *MC*-LSA

Page: 1-1

### 1. GENERAL INFORMATION

#### 1.1. *Manufacturer:*

Flight Design GmbH  
Sielminger Str. 51  
70771 L.-Echterdingen  
Germany

#### 1.2. *In the USA contact*

Flight Design USA  
P.O. Box 325  
South Woodstock, CT. 06267  
860-963-7272  
[airworthiness@flightdesignUSA.com](mailto:airworthiness@flightdesignUSA.com)



## Aircraft Operating Instructions (AOI)

Type: **MC**

Series: **MC-LSA**

Page: 1-2

### 1.3. Continued Airworthiness Instructions

Unlike other aircraft for which the Aviation Authority (FAA, EASA, ...) is responsible for the continued certification compliance, for Light Sport Aircraft, the burden of continued certification compliance rests on a cooperative effort between the manufacturer and the Owner/Operator of the aircraft. To this end, certain Manufacturer and Owner/Operator responsibilities are outlined in ASTM F 2295, Standard Practice for Continued Operational Safety Monitoring of a Light Sport Aircraft.

#### 1.3.1. Manufacturer Responsibilities

In order to fulfill the manufacturer's responsibilities, Flight Design USA maintains an Operational Safety Monitoring System that provides for the following practices:

A. Operational Safety Monitoring, a system by which:

1. Safety of Flight and Service Difficulties are reported by the Owner/Operator.
2. Safety of Flight and Service Difficulty issues are received, tracked, and evaluated by Flight Design USA.

B. B. Continued Airworthiness Support, a system by which:

1. Flight Design USA issues Safety Directives (Notices of Corrective Action) directed towards correcting Safety of Flight and Service Difficulty issues.
2. The Owner/Operator obtains and verifies that they have the latest safety of flight information developed by the manufacturer.

C. C. Maintenance Instructions

1. Provided to the Owner/Operator and pertaining to 100 hour and annual condition inspections.

D. D. Continued Airworthiness Instructions

1. Provided to the Owner/Operator and pertaining to maintaining the certification compliance of their S-LSA

#### 1.3.2. Owner/Operator Responsibilities and Instructions

F 2295 states that the Owner/Operator shall:

A. Read and comply with the maintenance and continued airworthiness information and instructions provided by the manufacturer.

*These instructions are included in the Aircraft Operating Instructions, Maintenance and Inspection Procedures and Flight Supplement manuals.*

B. Provide the manufacturer with current contact information where the manufacturer may send the Owner/Operator supplemental notification bulletins.

*At the time of delivery, the Owner/Operator will provide the contact information to Flight Design USA or its representative. Contact information may be updated at any time by:*

*Writing to: Flight Design USA P.O. Box 325, South Woodstock, CT 06267*

*Or email: [airworthiness@flightdesignusa.com](mailto:airworthiness@flightdesignusa.com)*



## Aircraft Operating Instructions (AOI)

Type: **MC**

Series: **MC-LSA**

Page: 1-3

- C. Notify the Manufacturer of any Safety of Flight issue or any significant Service Difficulty issue upon discovery.

*Safety of Flight report forms and Service Difficulty report forms can be found in the aircraft manuals and on the Operational Safety Monitoring page of the [Flightdesignusa.com](http://Flightdesignusa.com) website*

- D. Comply with all manufacturer issued notices of corrective actions and for complying with all applicable FAA regulations in regard to maintaining the airworthiness of the LSA airplane.

*Airworthiness information will be sent to the Owner/operator contact address of record. Airworthiness information can also be obtained from Safety section of the [Flightdesignusa.com](http://Flightdesignusa.com) website.*

- E. The Owner/operator shall ensure that any needed corrective action be completed as specified in a notice or by the next scheduled annual inspection.

**Important:** Should an Owner/Operator not comply with any mandatory service requirement, the LSA shall be considered not in compliance with the applicable ASTM Standards, and may be subject to regulatory action by the FAA.





## Aircraft Operating Instructions (AOI)

Type: **MC**

Series: **MC-LSA**

Page: 1-4

### 1.4. Main dimensions:

Geometry	
Max. length	6.520 m (21.4 ft.)
Max. height	2.590 m (8.5 ft.)
Wing span	9.5 m (31.2 ft.)
Areas	
Wing	11.3 m <sup>2</sup> (121.6 ft <sup>2</sup> )
Horizontal tail	2.04 m <sup>2</sup> (21.96 ft <sup>2</sup> )
Vertical tail	1.0 m <sup>2</sup> (10.76 ft <sup>2</sup> )
Aspect ratios:	
Wing	8.0
Horizontal tail	3.04
Vertical tail	1.52

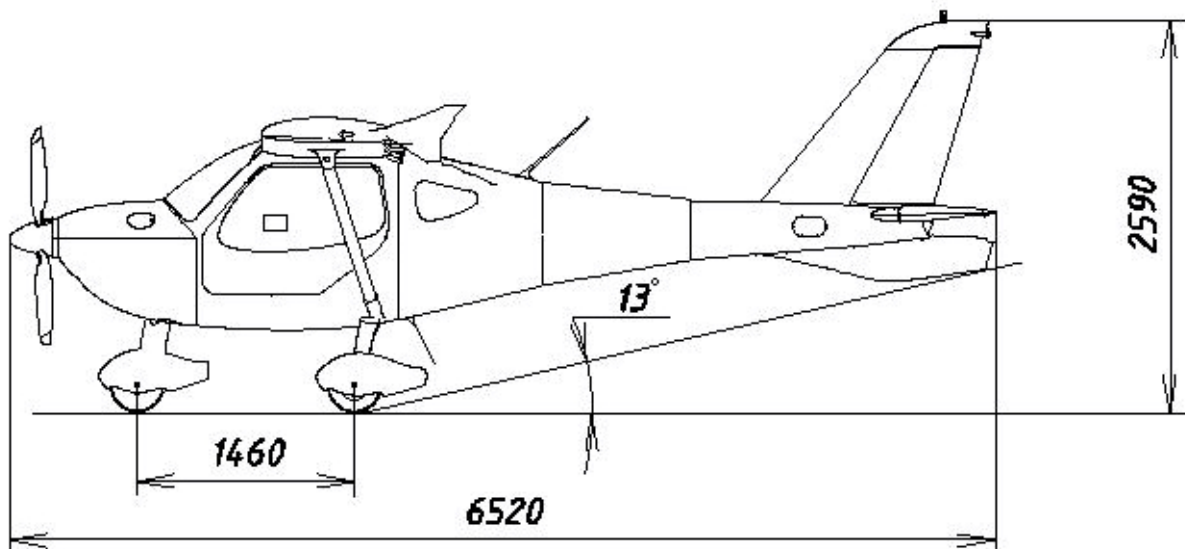



# Aircraft Operating Instructions (AOI)

Type: *MC*

Series: *MC*-LSA

Page: 1-5

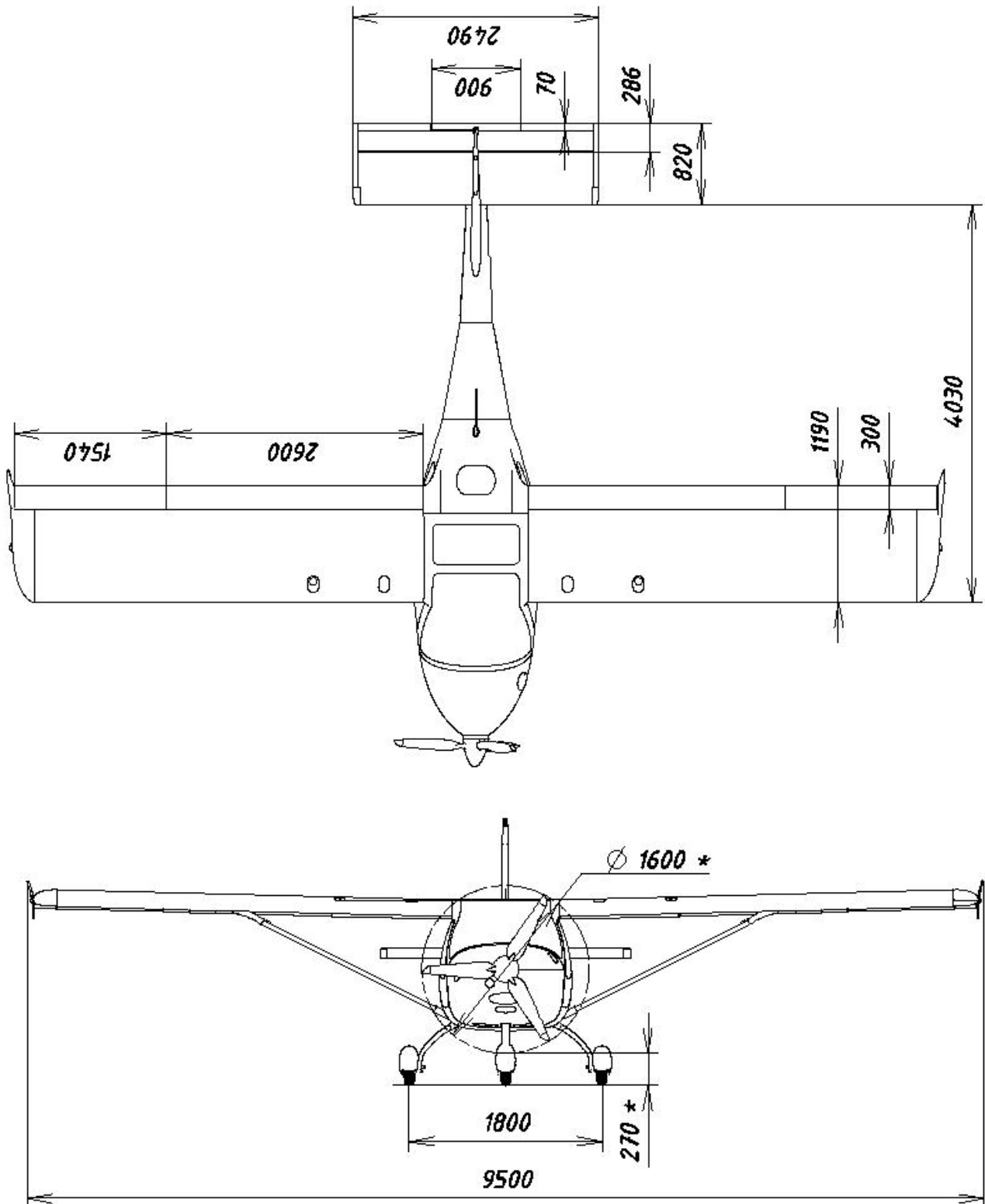



## Aircraft Operating Instructions (AOI)

Type: **MC**

Series: **MC-LSA**

Page: 1-6

### 1.5. Engine

The MC is available with the Rotax 912 UL with 80 rated BHP (also, Rotax 912 ULS with 100 rated BHP is available upon your request). More detailed information on the engine is available from Rotax for your specific engine serial number.

	<b>Rotax 912 ULS</b>
Engine type:	horizontally opposed, four cylinder, four stroke engine
Cooling:	water-cooled cylinder heads
Horsepower rating and engine speed:	73.5 kW / 100 rated BHP at 5800 rpm
Carburetor type:	Bing constant pressure carburetor
Ignition:	electronically controlled dual ignition
Propeller gear reduction:	2.43:1

### 1.6. Propeller

Various types of propeller are available for the MC. Each propeller has its own operating handbook and maintenance manual published by the propeller manufacturer. These documents are delivered with the aircraft and must also be studied in detail. The following types of propeller have been certified for the MC:

<b>Manufacturer</b>	<b>Parameters</b>
Neuform	TXR 2-65-47-101.6, 1.66 m diameter, 2 blade, composite propeller, ground adjustable
Neuform	CR3-65-47-101.6, 1.70 m diameter, 3 blade, composite propeller, ground adjustable
Kaspar- Brändel	KA1, 1.60 m diameter, 3 blade, composite propeller, ground adjustable
PowerFin	A R 65 T, 1.65 m diameter, 3 blade, composite propeller, ground adjustable



## Aircraft Operating Instructions (AOI)

Type: *MC*

Series: *MC*-LSA

Page: 1-7

### 1.7. *Minimum equipment*

Airspeed indication	up to at least 270 km/h (146 knots)
Altimeter	with Barometric adjustment possibility
Safety harness	four-point, one for each seat
Magnetic compass	with calibration
Engine indication	CHT, Oil Temp, Oil press, RPM.
Aircraft documents	national regulations apply

### 1.8. *Recommended additional equipment*

Ballistic recovery system	national regulations apply
Emergency locator transmitter (ELT)	mandatory in some countries
Radio	with intercom and headsets
Transponder	Mode C or S
External lighting	anti-collision light (ACL) and navigation lights, landing light



## Aircraft Operating Instructions (AOI)

Type: **MC**

Series: **MC-LSA**

Page: 2-1

### 2. LIMITATIONS

#### 2.1. Airspeed limitations

Stall speeds	flaps -12°	V <sub>s1</sub>	87 km/h	47 kts CAS
	flaps 0°	V <sub>s1</sub>	78 km/h	42 kts CAS
	flaps 15°	V <sub>s1</sub>	69 km/h	37 kts CAS
	flaps 30°	V <sub>s1</sub>	67 km/h	36 kts CAS
	flaps 35°	V <sub>s0</sub>	67 km/h	36 kts CAS
Maneuvering speed	V <sub>a</sub>	185 km/h	100 kts	CAS
Maximum flap extended speed	flaps 0°	V <sub>fe</sub>	166 km/h	90 kts CAS
	flaps 15°	V <sub>fe</sub>	152 km/h	82 kts CAS
	flaps 30°	V <sub>fe</sub>	136 km/h	73 kts CAS
	flaps 35°	V <sub>fe</sub>	130 km/h	70 kts CAS
Maximum rough-air speed	V <sub>ra</sub>	222 km/h	120 kts	CAS
Caution range		222 – 250 km/h	120 - 135 kts	CAS
Never-exceed speed (V <sub>ne</sub> )	V <sub>ne</sub>	250 km/h	135 kts	CAS

Maximum demonstrated crosswind	flaps 0°	30km/h	16 kts
	flaps 35°	20km/h	11kts

**Warning:** Take-off and landing with crosswinds require a lot of training and experience. The greater crosswind component, the more experience required.



## Aircraft Operating Instructions (AOI)

Type: **MC**

Series: **MC-LSA**

Page: 2-2

### 2.2. Flight load factor limits

Maximum flight load factor	up to $V_a$	+ 4g/ -2g
	up to $V_{ne}$	+ 4g/ -1.5g

**Warning:** Up to  $V_a = 185$  km/h (100 kts) (maneuvering speed) full control movements may be made.  
Above  $V_a$  all control surfaces may only be deflected to a third of their maximum displacement.

**Warning:** Up to  $V_{ra} = 222$  km/h (120 kts) IAS the MC can safely withstand a vertical gust of 15m/s (2955 FPM)  
Above  $V_{ra} = 222$  km/h (120 kts) IAS the MC can withstand the load of a vertical gust of 7.5 m/s (1478 FPM)

### 2.3. Tire pressure

Main landing gear	2.5 bar	36.3 psi
Nose landing gear	2.5 bar	36.3 psi

### 2.4. Mass and center of gravity limits:

Minimum weight, solo pilot	54 kg (119 lbs)
Maximum mass per seat	130 kg (286 lbs)
Typical Empty weight, incl. recovery system *	358 kg (788 lbs)
Maximum take-off weight (MTOW)	600 kg (1322 lbs)

Baggage compartment	25 kg** (55 lbs) maximum on each side
	50 kg** (110 lbs) maximum in total

Center of gravity range	<del>318 – 458 mm*** (12.5 inches – 18.0 inches)</del>
	318 – 392 mm*** (12.5 in – 15.4 in) ****

\* Nominal empty weight with minimum equipment. The true empty weight depends greatly upon the equipment installed. The current weight of each aircraft is registered in the current weighing record. Refer to Chapter 6 "Weight and Balance".

\*\* Maximum values. The correct values for each aircraft may be calculated from the current weighing record. Refer to Chapter 6 "Weight and Balance".

\*\*\* Reference datum is the wing leading edge with the aircraft in the neutral position. Refer to Chapter 6 "Weight and Balance".

\*\*\*\* Design rear cg limit is 458 mm / 18.0 in. Out of safety reasons at this point in time rear flight cg range limited (flight tests not fully completed for most rear cg position)

**Warning:** The weight data given are standard values. The correct data for each aircraft must be extracted from the current weighing record. Refer to Chapter 6 "Weight and Balance".



## Aircraft Operating Instructions (AOI)

Type: **MC**

Series: **MC-LSA**

Page: 2-3

### 2.5. Power plant limitations

	ROTAX 912 ULS
Maximum take-off power (at 5 800 RPM, max 5 min)	73.5 kW / 100 HP
Maximum continuous power (at 5 500 RPM)	69 kW / 93 HP
Maximum continuous engine speed	5500 RPM
Idle engine speed	1400 RPM
Cylinder head temperature, maximum	135°C (275°F)
Oil temperature, minimum	50°C (120°F)
Oil temperature, maximum	130°C (266°F)
Recommended operating temperature	90–110°C (190°F-230°F)
Oil pressure, normal operation	2.0–5.0 bar (29–73psi)
Oil pressure, minimum	0.8 bar (12 psi)
Oil pressure, short-term maximum during extreme cold start conditions	7 bar (101.5 psi)
Oil grade	brand automotive engine oils, no aviation oil - refer to the relevant ROTAX operating handbook for information on viscosity. Do not use oil additives
Oil tank capacity	2.0 - 3.0 l (2.1 – 3.1 quarts)
Oil consumption, maximum	0.06 l/h (0.063 q/h)
Fuel tank capacity	100 l (26.4 gal) - 2 wing tanks with 50 l (13.2) each tank capacity
Usable fuel	98 l (25.9 gallons)
Type of fuel	Premium Automotive unleaded per ASTM D 4814 Minimum AKI 91. For more complete information refer to the Rotax 912series Operators manual. Or AVGAS 100 LL.

\* Coolant temperature is monitored via the cylinder head temperature which is measured at the measuring point of the hottest cylinder

**Warning:** Due to its high lead content AVGAS has a detrimental effect on valve seating and causes greater deposition in the combustion chamber. It should thus only be used if fuel vapor or octane problems arise or if MOGAS is not available.



## Aircraft Operating Instructions (AOI)

Type: **MC**

Series: **MC-LSA**

Page: 2-4

**Warning:** When using AVGAS particular attention must be paid to type of oil used. For details refer to the valid version of the ROTAX engine manual.

**Warning:** The engine data given here is not complete. For complete information refer to the current version of the relevant engine manual from the Rotax company.

### **2.6. Other limitations**

**Warning:** The aircraft is **not** certified for aerobatics!

The aircraft may only be operated during the day in visual flight conditions.

Flight into instrument meteorological conditions (IMC) is prohibited.

Flight into icing conditions is prohibited.

Turns steeper than 60 degrees of bank are prohibited.

Flight operations are not recommended during strong, gusty winds or wind speeds on the ground of more than 40 km/h (21.6 kts).





### 3. EMERGENCY PROCEDURES

#### 3.1. *Emergency procedures checklists*

Emergency procedures are initially presented in the form of checklists. Amplified emergency procedures follow later in the chapter.

Even experienced pilots are strongly recommended to work with the checklists in the cockpit. It is the only way to ensure that in the distraction during flight important items are not overlooked.

The checklists are formulated so that they may be made into a small booklet which can be used in the cockpit. This booklet can be augmented with specific operational aspects should this be necessary.

The detailed procedures augment those points of the checklists which can only be explained in detail. It is important for safe operation that the pilot familiarize himself with these detailed procedures before starting flight operations.

<b>Spinning</b>		<b>Restarting the engine</b>	
Controls	neutral	Fuel shutoff valve	open
Rudder	opposite direction of rotation	Fuel amount	check
Rotation	stopped	Ignition	both
Throttle	retard	Propeller stopped	ignition key to start
Elevator	smooth recovery from dive	Engine fails to restart	make an emergency landing
<b>Deploying the ballistic recovery system</b>		<b>Emergency landing</b>	
Ignition	off	No suitable landing field	deploy recovery system
Recovery system	release	Landing field	selected
Fuel shutoff valve	off	Safety harness	tight
Emergency radio call	transmit	Objects in cockpit	securely stored
Master switch	off	Emergency radio call	transmit
Safety harness protective position	tight taken	Flaps	as required
<b>Engine failure</b>		Airspeed	as required
Below 100m (300 Ft) AGL	make an emergency landing straight ahead	Flare	50 cm (20 in.) above ground or tree tops
Above 200m (600 Ft) AGL	refer to procedures for restarting the engine	Ignition during flare	off
		Fuel shutoff valve	closed
		Elevator on touchdown	tail low
		ELT	automatic / as required



## Aircraft Operating Instructions (AOI)

Type: **MC**

Series: **MC-LSA**

Page: 3-2

<p><b>Engine fire</b></p> <p>Fuel shutoff valve            off          Throttle                        full          Ignition                         off          Ignition key                    remove          Flight attitude                slip away from flames          Landing                         make an emergency landing</p> <p><b>Loss of coolant</b></p> <p>Engine power                 reduce          Cylinder head temperature below 150°C          Landing                         as soon as possible at airfield</p> <p><b>Loss of oil</b></p> <p>Ignition                         off          Ignition key                    remove          Fuel shutoff valve            off          Landing                         make an emergency landing</p>	<p><b>Failure of flap control</b></p> <p>Alternator                        off          Master switch                 off          Master switch                 after 3 seconds to on          Alternator                        on          If everything okay             end of procedure          Flaps in cruise flight        manually set to max. negative          Long runway                 landing flap max. negative          Short runway                 in short final, manually set to max. positive</p> <p><b>EMS failure</b></p> <p>Reduce airspeed                185 km/h (100 knots) with flaps negative</p>
--	---



## Aircraft Operating Instructions (AOI)

Type: *MC*

Series: *MC*-LSA

Page: 3-3

### 3.2. Stalls

The stall characteristics in level flight are docile. Normal flight attitude can be recovered by pushing the stick forward, increasing speed and then smoothly pulling the aircraft up again.

Maximum loss of altitude during stall recovery is 50m (164 ft). Pitch down does not exceed 25°.

The aircraft does not go into a spin during a stall in a 30° turn. Normal flight attitude can be recovered by pushing the stick forward, increasing speed and then smoothly pulling the aircraft up and simultaneously correcting the angle of bank.

Maximum loss of altitude during recovery is 60 m (197 ft). The angle of bank does not exceed 60°.

### 3.3. Inadvertent spin

The aircraft shows no inclination to go into an inadvertent spin during normal stall or during stalls in turns.

Should the aircraft, however, inadvertently enter into a spin, the following recovery procedure should be used:

All control surfaces in neutral position

When rotation does not stop immediately:

rudder slightly opposite to direction of rotation

retard throttle

Smooth recovery in the neutral attitude

**Warning:** When encountering an inadvertent spin, airspeed increases quickly during a dive. It is essential that attention be paid to airspeed limitations, control surface deflection and flight load factors when recovering the aircraft from a steep dive.

**Warning:** Should the attempt to recover the aircraft fail or should recovery appear doubtful due to low altitude, the recovery system should be deployed.



## Aircraft Operating Instructions (AOI)

Type: *MC*

Series: *MC*-LSA

Page: 3-4

### 3.4. Emergency landing

An emergency landing may be necessary for several different reasons. In addition to the loss of lubricants or the failure of aircraft systems, ominous weather conditions may also lead to an emergency landing.

In order to carry out an emergency landing, a suitable landing site must be found. It should be free of obstacles - including the approach - and should be long enough. The final approach to the site should be flown at the usual approach speed of 100 km/h (54kts).

The following points should be implemented during the approach:

Safety harness	lap belt tight, shoulders snug
Loose objects in the cockpit	securely stored
Radio signal	transmit to the appropriate ATC or to a nearby airfield so that the emergency services can be informed if necessary.

During a landing on unknown terrain it is recommended that the landing be accomplished at minimum safe speed. The landing flare should be initiated at approx. 50 cm (2 ft.) above the ground and the aircraft slowed down to minimum speed.

During flare it is recommended that the engine be shut down in order to reduce as far as possible the danger of a fire:

Ignition	off
Fuel shutoff valve	closed

On touchdown, the stick should be pulled back smoothly to prevent as far as possible overturning on landing caused by the nose wheel sinking into soft ground. Apply the brakes smoothly to bring the aircraft to a controlled stop.

During landings in cornfields, the tops of the trees or other crops should be seen as the landing surface. On short finals the flaps should be fully extended and airspeed should be 90 km/h (48 knots). The landing flare should be initiated at approx. 50 cm (2 ft.) above the assumed landing plain and the aircraft slowed down to minimum speed. On touchdown the stick should be pulled back smoothly to prevent as far as possible overturning on landing.

**Warning:** If urgent help is required after a forced landing, the ELT (if installed) can be activated manually thus alerting the search and rescue services.

**Warning:** Every MC is delivered with a fire extinguisher in a pocket on the back of the passenger seat. It can be used to fight small fires in the cockpit.

Should a forced landing not be possible and should the aircraft be at a sufficiently high altitude, the ballistic recovery system may be deployed. Refer to special emergency procedures for the deployment of the recovery system.



## Aircraft Operating Instructions (AOI)

Type: *MC*

Series: *MC*-LSA

Page: 3-5

### 3.5. *After overturn on landing*

Due to its design, the MC offers good occupant protection during an overturn. Should you find yourself in this situation, brace yourself with your legs against the windshield. Unhook your safety harness. Be careful not to injure yourself on shards from the windshield or broken parts of the structure when you drop out of the seat. Evacuate the aircraft as quickly as possible.

**Warning:** Check for leaking fuel when evacuating the aircraft - acute fire hazard - the fuel system is not designed for the upside-down position.

**Warning:** If urgent help is required after an emergency landing, the ELT (if installed) can be activated manually thus alerting the search and rescue services.

**Warning:** Every MC is delivered with a fire extinguisher in a pocket on the back of the passenger seat. It can be used to fight small fires in the cockpit.



### 3.6. Deploying the ballistic recovery system

Refer to the operating handbook published by the manufacturer of the recovery system for operating details. The recovery system can be deployed in relatively low altitudes. If deployed at a low airspeed, the damage to the aircraft can be kept to a remarkable minimum. Due to the position in which the aircraft is suspended from the parachute, the pilot is as well protected as possible during the deployment of the recovery system.

For the deployment of the ballistic recovery system the manufacturer gives the following sequence of activities. The manufacturer's manual provides further details the pilot has to acknowledge prior to first flight with the aircraft.

Kill the engine (that the rotating prop does not damage the parachute) – deploy the parachute (to do this, pull the handle with force to the very end, until the rocket has started) – re-tighten your seat belts (that they give best protection at touchdown) – brace yourself (hands in the neck, arms to protect face and head).

The release lever is located in the centre console between the seats. In an emergency, the lever must be pulled forcefully forward to detent.

**Warning:** Read recovery system operation manual for mandatory information provided by the recovery system manufacturer.

**Warning:** Once the recovery system is activated, the pilot gives up all active control of the aircraft. There is no possibility to release the parachute and return to aerodynamic flight.

**Warning:** The activation of the rescue system depends on the situation and is in the pilot's decision. Once you decided to activate the rescue system do it at once and do not waste precious time. Before deployment, if possible, tighten lap belts tight, shoulder harnesses snug.

**Warning:** The rescue system requires a certain time – and therefore altitude – to be fully deployed. In an emergency where the pilot has no more control about the aircraft, the recovery system should be deployed regardless of altitude.

**Warning:** Maximum speed for deployment is 178 kts (276 km/h) IAS. Should the condition of the aircraft permit, aircraft speed should be reduced to below this value. If unavoidable, the recovery system can be deployed at a speed above the maximum. The parachute is attached to the aircraft at multiple hard points, so the chances of recovery are still good.

**Warning:** If urgent help is required after a landing using the recovery system, the ELT (if installed) can be activated manually thus alerting the search and rescue services.

**Warning:** Every MC is delivered with a fire extinguisher in a pocket on the back of the passenger seat. It can be used to fight small fires in the cockpit.



## Aircraft Operating Instructions (AOI)

Type: *MC*

Series: *MC*-LSA

Page: 3-7

### 3.7. Engine failure

**Warning:** Do not attempt to restart the engine at altitudes below 100 m (328 ft)

**Warning:** Do not attempt to return to the airfield if engine failure occurs immediately after take-off below an altitude of 250 m (820 ft).

**Warning:** Due to the increased loss in altitude, turns should not be attempted at altitudes below 50 m (164 ft).

After an engine failure in flight, an engine restart should be attempted if altitude and time permits. The prerequisites for a successful restart should first be checked:

Fuel shutoff valve	open
Amount of fuel	fuel available in both wing tanks
Ignition	both

If the fuel level is low in both tanks and one of the fuel tanks appears to be empty, level the wings and make certain that the aircraft is not side slipping or holding the wing with the apparently empty tank higher. If the aircraft is level and one of the tank indicators shows fuel available make certain you keep that wing slightly higher to ensure fuel is being supplied to the engine.

If airspeed is so low that the propeller has stopped, the engine must be started in the same way as on the ground using the starter.

The Rotax 912 series engine ignition is only active once a certain minimum propeller rpm is achieved (above 1200 RPM). If the propeller is wind-milling, it may be that the propeller rpm is too low to restart the engine. In this case the starter must be used.

**Warning:** Restarting the engine requires the full attention of the pilot. The stress factor in the cockpit increases considerably and simple mistakes may be made by even the most experienced pilot. It is therefore imperative that you continue to fly the aircraft! Be careful of controlled flight into terrain and other hazards of distraction.

If the engine can not be restarted or if altitude does not allow an attempt to restart, a controlled forced landing should be carried out.

The power-off emergency landing procedure is basically the same as an emergency landing with engine power. The best glide speed is 140 km/h (76 knots) at a flight mass of 600 kg (1320 lbs). The flaps should be set to 0°. The flaps should only be extended beyond 0° when it is assured that the landing field will be reached. If you arrive too high at the chosen field perform descending figure 8's keeping the landing site in view until the turn for final approach.

**Warning:** During a landing without engine power, the glide path cannot be extended. Due to flap effectiveness and side-slipping, the glide path can be shortened considerably. Choose a landing field that you can glide to with certainty.



## Aircraft Operating Instructions (AOI)

Type: *MC*

Series: *MC*-LSA

Page: 3-8

### 3.8. Carburetor or engine fire

If a fire breaks out in the engine compartment, the fuel shutoff valve must be turned off immediately. Throttle to full open to allow the engine to use up the fuel in the system quickly. Turn the Ignition off and take out the ignition key to ensure that the ignition is not inadvertently turned. Check that the fuel shutoff valve is still completely closed. In the fully closed position the lever is covering the slot for the ignition key.

Descend as quickly as possible, holding the flames away from the aircraft by side slipping and perform an emergency landing similar to that without engine power.

If the flames have been extinguished and an emergency landing cannot be performed without engine power, an attempt may be made to restart the engine - should it indeed restart, an emergency landing should be made immediately.

The deployment of the recovery system can be a good alternative.

If the aircraft has become uncontrollable during the fire or if an emergency landing cannot be performed, the recovery system should not be deployed at greater altitudes, i.e. descend to an altitude of approx. 200 m (656 ft) (make sure that the maximum deployment speed for the recovery system is not exceeded). The recovery system can then be deployed.

Evacuate the aircraft immediately after landing.

**Warning:** Every MC is delivered with a fire extinguisher in a pocket on the back of the passenger seat. It can be used to fight small fires in the cockpit.





## Aircraft Operating Instructions (AOI)

Type: *MC*

Series: *MC*-LSA

Page: 3-9

### **3.9. Loss of coolant**

A loss of engine coolant does not mean that a forced landing must be carried out immediately.

The coolant is used solely to cool the cylinder heads. The cylinders are air-cooled. As coolant temperature is only indirectly indicated via the cylinder head temperature of the hottest cylinder, engine temperature monitoring is still possible even after a total loss of coolant.

In the case of a loss of coolant, engine power should be reduced enough to ensure that the cylinder head temperature remains within normal operation limits (below 150°C - 302°F). If airspeed becomes too low, the flaps may be partially extended (from 0° to 15°). The aircraft can then be flown to a suitable airfield without causing permanent damage to the engine.

If the temperature cannot be held within operating limits, one must decide whether one is prepared to risk damage to the engine in order to reach a suitable field for an emergency landing.

### **3.10. Loss of oil**

A loss of oil is a very serious condition as the hot oil can easily ignite if it drops on to the hot exhaust system. An emergency landing performed to the procedures described above should be carried out as soon as possible.



## Aircraft Operating Instructions (AOI)

Type: *MC*

Series: *MC*-LSA

Page: 3-10

### 3.11. Failure of flap control

The flap motor is activated by a controller which allows the preselection of the desired flap position. The flap position is indicated digitally.

In principle, the MC can be landed irrespective of flap position. However, with negative flaps, the stall speed is higher and the resulting landing distance longer. When in doubt, an alternate airfield with a longer runway should be chosen. Recommended approach speed with flaps 0° is 100 km/h - 54 kts. With flaps -12° the recommended approach speed increases to 120 km/h – 65 kts.

Should the control unit fail (not the motor), the electronic control of the flap motor should be reset. This is achieved by switching the alternator switch and the master switch off and then on again. It is safe to do this in flight as engine ignition is independent from the aircraft's power supply. Should this not work, the flaps can be set manually by moving the flap selection lever past the detent, up or down.

To set the flaps to negative, the flap lever is moved past and above the -12° position. Once the desired setting has been reached, the lever is returned to the -12° position. The flaps remain in the set position.

To set the flaps to positive, the flap lever is moved past and below the +35° position. Once the desired setting has been reached, the lever is returned to the +35° position. The flaps remain in the set position.

**Warning:** If the lever is not returned from the manual position, the flap motor continues to run until the end position is reached.

**Warning:** As the flap position is no longer regulated by the controller, the pilot must ensure that airspeeds for flight with flaps extended are not above the limits shown on the flap lever placard.

### 3.12. Dynon EMS failure (if installed)

Dynon EMS failure (if installed) does not automatically adversely affect flight safety. However, should the Dynon EMS fail completely, engine parameters can no longer be monitored by the pilot. In order to reduce the risk of damage to a minimum, the flight may be continued but engine speed should be kept moderate (160 km/h – 85 kts) cruise speed with negative flaps. Sailplane towing or banner towing should be stopped when this failure occurs.

## 4. NORMAL PROCEDURES

### 4.1. Normal procedures checklists

Normal procedures are initially presented in the form of checklists. Amplified normal procedures follow later in the chapter.

All pilots are strongly recommended to work with the checklists in the cockpit. It is the only way to ensure that in the distractions that may arise during flight important points are not overlooked.

The checklists are formulated so that they may be made into a small booklet which can be used easily in the cockpit. This booklet can be augmented with specific operational aspects including helpful local information.

The amplified procedures augment those points of the checklists which can only be explained in detail. Self-explanatory points will not be further dealt with. Both sources (checklists and amplified procedures) should be used during normal operation.

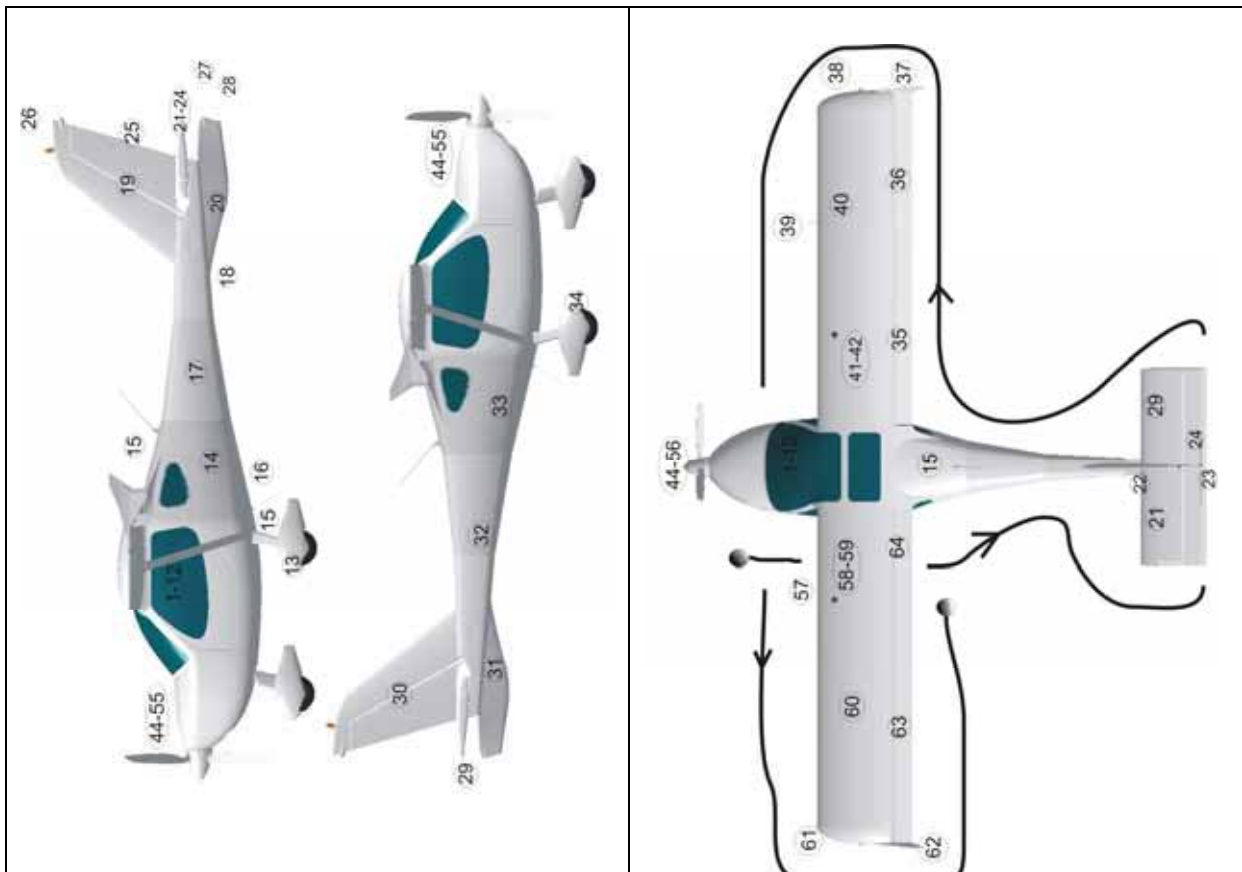



# Aircraft Operating Instructions (AOI)

Type: **MC**

Series: **MC-LSA**

Page: 4-2

## PREFLIGHT INSPECTION

### A. Cabin

- |                        |                                     |
|------------------------|-------------------------------------|
| 1 Aircraft documents   | on board                            |
| 2 Control surfaces     | free and correct                    |
| 3 Main pins            | inserted, caps in place and secured |
| 4 Ignition             | off, key removed                    |
| 5 Electrical equipment | off                                 |
| 6 Avionics switch      | off                                 |
| 7 Master switch        | on                                  |
| 8 Wing flaps           | extended                            |
| 9 Master switch        | off                                 |
| 10 Fuel shutoff valve  | open                                |
| 11 Doors               | function checked                    |
| 12 Windows             | check                               |

## PREFLIGHT INSPECTION

### B. Left side of aircraft

- |                                     |                     |
|-------------------------------------|---------------------|
| 13 Main landing gear, tire, fairing | check               |
| 14 Baggage compartment              | locked              |
| 15 Antennas                         | undamaged           |
| 16 Static pressure source           | check clear         |
| 17 Fuselage                         | no damage           |
| 18 Rear tie-down                    | remove              |
| 19 Vertical tail                    | check               |
| 20 Underfin                         | check               |
| 21 Horizontal tail                  | check               |
| 22 Elevator's link (piano hinge)    | check               |
| 23 Trim tab                         | check               |
| 24 Trim tab link (piano hinge)      | check               |
| 25 Rudder                           | check cables, bolts |
| 26 Rudder ACL                       | check               |
| 27 Tow release                      | check               |
| 28 Tail navigation light            | check               |

## PREFLIGHT INSPECTION

### C. Right side of aircraft

- |                                      |        |
|--------------------------------------|--------|
| 29 Horizontal tail                   | check  |
| 30 Vertical tail                     | check  |
| 31 Underfin                          | check  |
| 32 Fuselage                          | check  |
| 33 Baggage compartment               | locked |
| 34 Main landing gear, tire, fairings | check  |

### D. Right wing

- |                      |            |
|----------------------|------------|
| 35 Wing flap         | check      |
| 36 Aileron           | check      |
| 37 Winglet, wing tip | check,     |
| 38 Navigation light  | check      |
| 39 Pitot probe       | check      |
| 40 Tie-down          | remove     |
| 41 Fuel quantity     | check      |
| 42 Filler cap        | shut       |
|                      | Vent clear |
| 43 Wing leading edge | check      |

## PREFLIGHT INSPECTION

### E. Aircraft - Nose

- |                      |                         |
|----------------------|-------------------------|
| 44 Engine cowling    | remove                  |
| 45 Exhaust system    | check                   |
| 46 Nose gear         | check                   |
| 47 Air inlet         | check                   |
| 48 Fluid lines       | check                   |
| 49 Electrical wiring | check                   |
| 50 Fuel              | drain; no contamination |
| 51 Landing light     | check                   |
| 52 Propeller         | check                   |
| 53 Spinner           | check                   |
| 54 Battery           | check                   |
| 55 Oil quantity      | check                   |
| 56 Coolant quantity  | check                   |

### F. Left wing

- |                      |            |
|----------------------|------------|
| 57 Wing leading edge | check      |
| 58 Fuel quantity     | check      |
| 59 Filler cap        | shut       |
|                      | Vent clear |
| 60 Tie-down          | remove     |
| 61 Navigation light  | check      |
| 62 Winglet, wing tip | check,     |
| 63 Aileron           | check      |



# Aircraft Operating Instructions (AOI)

Type: **MC**

Series: **MC-LSA**

Page: 4-3

## STARTING THE ENGINE

Preflight inspection	complete
Parking brake	set
Carburetor heat	off
Circuit breakers	all in
Avionics	off
Master switch	on
ACL	on
Fuel shutoff valve	on (up)
Ignition key	in
Choke	as required
Throttle	idle
Propeller area	clear
Ignition key	turn to start then release
Choke	adjust, then off (forward)
Oil pressure	check
Alternator	switch on
Avionics	switch on
Wing flaps	retract

## TAXIING

Brakes	check
Steering	check

## BEFORE TAKE-OFF

Parking brake	set
Safety harnesses	lap tight, shoulders snug
Doors	shut
Control surfaces	free
Altimeter	set to field elevation
Transponder	on, standby
Choke	shut
Carburetor heat	off
Throttle	4000 RPM
Engine gauges	check
Magneto, left	max. drop 300 RPM
Magnetos, both	check
Magneto, right	max. drop 300 RPM
	max. diff. 120 RPM
Magnetos, both	check
Oil temperature	min. 51°C (122°F)
Alternator control lamp	off
Throttle	idle
Flaps	set
Pitch trim	set (neutral for takeoff)
Radios	set
Recovery system	unlocked (pin out)
ELT	armed

... continued ...

## BEFORE TAKE-OFF (continued)

Passenger briefing	complete
Approach & departure	clear
Parking brake	release

## NORMAL TAKE-OFF

Wing flaps	0° - 15°
Carburetor heat	off
Throttle	full
Take-off rpm	4800 – 5000 RPM
Best rate-of climb	100 km/h (54 kts) (flaps 15°)
	113 km/h (61 kts) (flaps 0°)
	124 km/h (67 kts) (flaps -12°)
Best angle-of-climb	90 km/h (48 kts) (flaps 15°)
	102 km/h (55 kts) (flaps 0°)
	113 km/h (61 kts) (flaps -12°)

## SHORT FIELD TAKE-OFF

Wing flaps	15°
Parking brake	set
Choke	shut
Carburetor heat	off
Throttle	full
Parking brake	release
Rotation	90 km/h (49 kts)
Acceleration	90 km/h (49 kts)
Best angle of climb	90 km/h (49 kts)

## CLIMB

Wing flaps	-12°, 0°
Airspeed @ -12° and 600 kg (1320 lbs) for	
... best rate-of-climb	V <sub>y</sub> = 124 km/h (67 kts)
... best angle-of-climb	V <sub>x</sub> = 113 km/h (61 kts)
RPM	max. 5500 RPM

## CRUISE

Throttle	as required
Engine parameters	in the green

## DESCENT

Carburetor heat	as required
Altimeter	set to field barometric

## BEFORE LANDING

Safety harnesses	tight
Airspeed	110 km/h (61 kts)
Wing flaps	15° ... 35°
Landing light	as required



## Aircraft Operating Instructions (AOI)

Type: *MC*

Series: *MC*-LSA

Page: 4-5

### NORMAL LANDING

Approach airspeed	90 km/h (48 kts)
Flaps in finals	15° or 30° as required
Airspeed on final	90 km/h (48 kts)
Flare	smoothly, nose not too high
After touchdown	stick smoothly back to relieve nose wheel

### AFTER LANDING

Throttle	idle
Brakes	as required
Carburetor heat	off
Landing light	off
Wing flaps	retract

### GO-AROUND

Throttle	full
Carburetor heat	off
Rate of climb	confirm positive rate
Wing flaps	15°
Airspeed	90 km/h (49 kts)
Rate of climb	continue positive rate

### SHUTTING DOWN THE ENGINE

Parking brake	set
Avionics	off
Electrical equipment	off
Alternator	off
Ignition	off
Master switch	off
Ignition key	remove
Recovery system	lock (pin in)
ELT	check off

### Passenger briefing

Safety harness	instructed
Door lock	instructed
Recovery system	instructed
Fire extinguisher spray	instructed
ELT remote control	instructed

	<b>Aircraft Operating Instructions (AOI)</b>	
	Type: <i>MC</i>	Series: <i>MC</i> -LSA
		Page: 4-6

#### **4.2. Preflight inspection**

Even if the MC was operated within the last 24 hours, it is essential that the aircraft be thoroughly inspected before the first flight of each day. This also means removing the engine cowling.

**Warning:** The inadvertent start-up of the engine is dangerous! Always ensure that the ignition and master switch are off.

Inspection details are given in the Rotax engine operating handbook. This pilot's operating handbook can only deal with the more important points.

Oil quantity can only be checked after the propeller has been slowly cranked (always crank in the rotation direction of the propeller, never against the direction of rotation) until a gurgling noise is clearly heard. Only then has the measurable amount of oil been transported into the oil reservoir. The amount of oil must lie between the two limits on the oil dipstick - max. /min. - and should never be allowed to sink below the minimum level. Before undertaking an extended trip, make sure that the oil level lies at least midway between the two limits. Do not overfill the tank.

**Warning:** If leakage of operating liquids is discovered, the engine may not be started until the cause of the leakage has been rectified. This is particularly important in the case of oil and fuel leaks as both constitute a fire risk.

The various propellers which can be installed in the MC are made of light-weight composite materials. In comparison to propellers from the General Aviation sector, these propellers do not consist of a wooden core which has been covered with composite material. Should such a full-composite propeller be damaged, then the entire load-carrying structure is affected. The propeller can no longer be used and must be inspected by a qualified technician. The same applies to the spinner. It is subject to high loads which can cause the smallest damage to grow very quickly. If it is damaged it too may no longer be used. If necessary, the aircraft may however be flown to an aviation workshop without the spinner cap.

Should cracks appear in the finish, the cause should be sought immediately. Cracks in composite structures are often indication of damage to the underlying structure. A qualified technician often has the means to check the structure without first having to remove the finish.

During the inspection of the cockpit and the baggage compartment, particular attention should be paid to loose objects. Objects easily fall out of bags and/or pockets when leaving the aircraft. These objects can then shift during flight and interfere with the control surfaces.

When flying alone, the passenger seat safety harness should be pulled tight and locked. No loose objects should be on the passenger side as they are not accessible to the pilot during flight.

**Warning:** The passenger seat is not intended for the transport of objects or bags. However, should objects (e.g. bags) be placed on the passenger seat,

AA 04300001	Revision No. 00	Date: 10 July 2009
-------------	-----------------	--------------------

	<b>Aircraft Operating Instructions (AOI)</b>	
	Type: <i>MC</i>	Series: <i>MC</i> -LSA
		Page: 4-7

they must be secured so that they cannot shift even if the aircraft experiences strong vertical gusts and accelerations.

#### **4.3. Passenger briefing**

Before take-off, passengers should be briefed on the emergency procedures. This ensures that in an emergency passengers will act properly and not become a further problem for the pilot.

Even although one can confidently assume that these circumstances may never happen, it is important that they be discussed calmly on the ground. In this way, one can be sure that if it comes to it, the passenger will react correctly. The briefing should include at the least the following points.

Passengers should be briefed on the proper use of the safety harness - how it is worn, locked, tightened and opened. The safety harness is tightened first at the waist and then the shoulders in order to prevent the lap strap from riding up in a dangerous manner. The safety harness should be held tight at all times as light aircraft such as the MC can experience turbulence at any time during flight.

The door latching mechanism should be demonstrated. Particular emphasis should be placed on the fact that the doors must be pulled firmly against the door seals before locking the doors in order to prevent the latches from jamming.

Deployment of the recovery system should be explained. Passengers must be told of the importance of the handle in the middle console and how to operate it. In the unlikely event that the pilot is incapacitated, this information is very important.

**Warning:** Even if the passenger is an experienced General Aviation pilot, he/she should be briefed on the peculiarities of Light Sport aircraft. This is especially the case with respect to the parachute recovery system as these are usually not installed in GA aircraft.

A fire extinguisher spray is provided in a pocket on the back of the passenger seat. It can be used to extinguish small fires in the cockpit. This may be necessary after an emergency landing. Briefing passengers accordingly on the use of the fire extinguisher spray is very important.

If immediate help is required after an emergency landing, the ELT (if installed) can be activated using the remote control in the lower central panel. If the pilot is no longer capable of acting, the passenger should know how he can activate the unit. This information is very important.

AA 04300001	Revision No. 00	Date: 10 July 2009
-------------	-----------------	--------------------



	<b>Aircraft Operating Instructions (AOI)</b>	
	Type: <i>MC</i>	Series: <i>MC</i> -LSA

#### **4.4. Starting the engine**

The fuel shutoff valve is positioned so that it impedes the turning of the ignition key so that it is virtually impossible to forget it completely. However, before starting the engine one should make sure that the valve is completely open as only then is the supply of sufficient fuel to the engine guaranteed.

Before starting the engine, it should be cranked manually in the direction of rotation to prevent a hydraulic lock and thus damage to the engine. The safety regulations given in the engine operating handbook must be followed.

**Warning:** When starting the engine, the pilot's attention is directed to inside the cockpit. The parking brake should thus be applied to prevent the aircraft from moving. Should the aircraft, despite parking brake, start to taxi after the engine has been started, the engine must be cut immediately by turning off the ignition. The aircraft has a tendency to move with the engine in idle when on concrete or if a tail wind prevails.

To start the engine, the starter should be activated for a maximum of 10 seconds. This prevents over-heating and a continuous over-loading of the battery. A cool down period lasting two minutes is recommended between attempts at starting.

Pull the choke out completely and keep it fully open for about 20 - 30 seconds after the engine starts to turn, then slowly push shut. Adjust the throttle as required. The throttle must be closed (full aft on lever) during choke operation for mixture enrichment to function.

Since the engine has a propeller gearbox, start-up impact loads should be avoided. When starting the engine the throttle should not be more than 10% open. Once the engine starts to turn, the throttle should be adjusted to ensure that the engine runs smoothly. This is usually the case at engine rpm between 2000 and 2500 RPM.

**Warning:** Oil pressure must begin to show at the latest 10 seconds after the engine has started to turn. If this is not the case, the engine must be cut immediately. Engine RPM may only be increased once oil pressure exceeds 2 bar (28 psi).

Allow the engine to warm up at medium RPM. We recommend 2 minutes at 2000 RPM and then increase to 2500 RPM. The engine is ready for operation when the oil temperature has reached 50°C (122°F).

#### **4.5. Autopilot operation**

The autopilot master switch should be in the off position when the engine is started. After the engine is started, turn on the autopilot master switch and hold the aircraft stationary as the internal gyros are initialized. The model and software version will be displayed briefly. For approximately ten seconds afterward, the display will show the words PWR UP in the lower display. When initializing is complete PWR UP will change to AP OFF.

The autopilot can be turned on and off by pressing the control buttons on the Autopilot controller itself. The Autopilot can also be turned on and off using the white button on the control stick.

AA 04300001	Revision No. 00	Date: 10 July 2009
-------------	-----------------	--------------------

	<b>Aircraft Operating Instructions (AOI)</b>	
	Type: <i>MC</i>	Series: <i>MC-LSA</i>
		Page: 4-9

For more details regarding the Autopilot operation please take the time to look at the Autopilot manual.

**Warning:** Do not mistake the autopilot button on the control stick with the Radio Transmit button. During the flight pay attention that you DO NOT press unintentionally white button on the control stick because it turns on and off the autopilot.

**Warning:** Normally the Autopilot is using your GPS Track as source for the course it tries to follow. In this case you see “TRK” in the upper half. When your plane holds wings level, but does not follow the selected route in your GPS, check if the Autopilot has lost the GPS signal. This can be clearly seen in the display, as the “TRK” display is gone and replaced by “NO GPS BANK”. In this backup mode the Autopilot tries to hold the wings according to the selected bank angle.

#### **4.6. Before take-off**

A flight should only be undertaken after a proper flight planning has been completed. Even if only pattern training is planned, you should first check if the runway length suffices under the prevailing conditions (surface conditions, wind, humidity, temperature).

The relevant checklist should be properly executed before each take-off. Small mistakes - such as the wrong flap setting - can lead to unanticipated developments during take-off and quickly lead to problems, for example on short runways with obstacles.

#### **4.7. Typical pattern**

The typical pattern can serve as a guidance for the suitable flight configuration during the various different phases of the pattern. In practice, it must, of course, be modified to take into account external influences, local circumstances or a compulsory pattern. Nevertheless you will be able to find the individual points again.

Following charts show two variants of traffic patterns. The big one is used when flying together with General Aviation Aircraft in the same pattern. In order to not slow them down flaps are retracted relatively early, and portions of the pattern are flown at good speed. The pattern is more roomy and fast. The small pattern can be flown on typical small light sport or private airstrips, and together with slower aircraft. Emphasis is laid upon keeping flaps set and speed controlled within the lower but safe limits. The pattern can be flown much more narrow this way, without generating pilot overload.

AA 04300001	Revision No. 00	Date: 10 July 2009
-------------	-----------------	--------------------

## Typical Large Traffic Pattern MC

This pattern only serves as an example for a traffic pattern flown together with other General Aviation Aircraft. It has to be adapted to local circumstances (obstacles for example) and requirements (official traffic patterns for example).  
**Provided data are for orientation only and do not replace Checklists or Procedures described in more detail within this manual.**

In gusty conditions the given airspeeds have to be enhanced with suitable reserves.

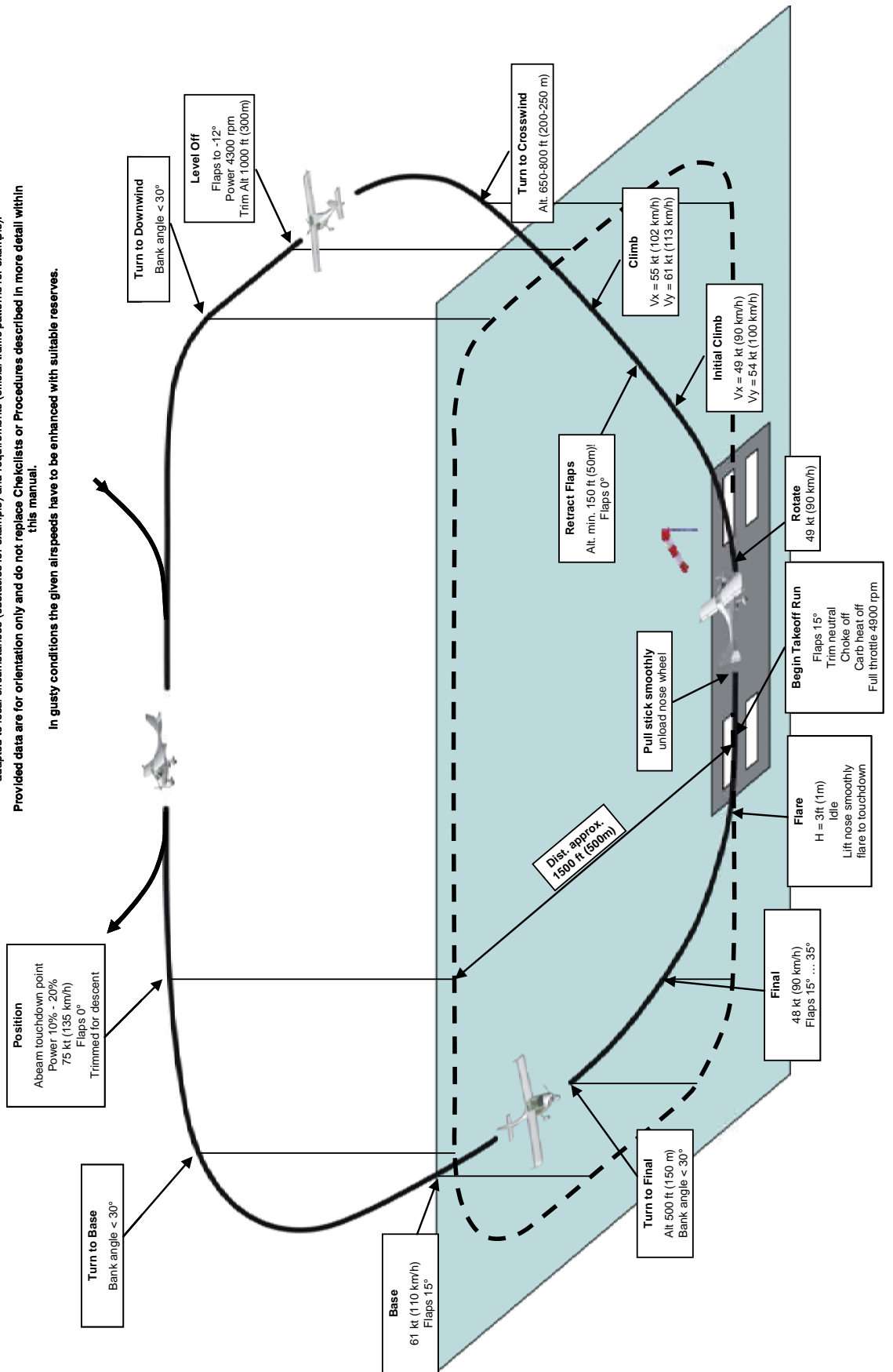

## Typical Small Traffic Pattern MC

This pattern only serves as an example for a Light Sport traffic pattern. It has to be adapted to local circumstances (obstacles for example) and requirements (official traffic patterns for example). Provided data are for orientation only and do not replace Checklists or Procedures described in more detail within this manual.

In gusty conditions the given airspeeds have to be enhanced with suitable reserves.

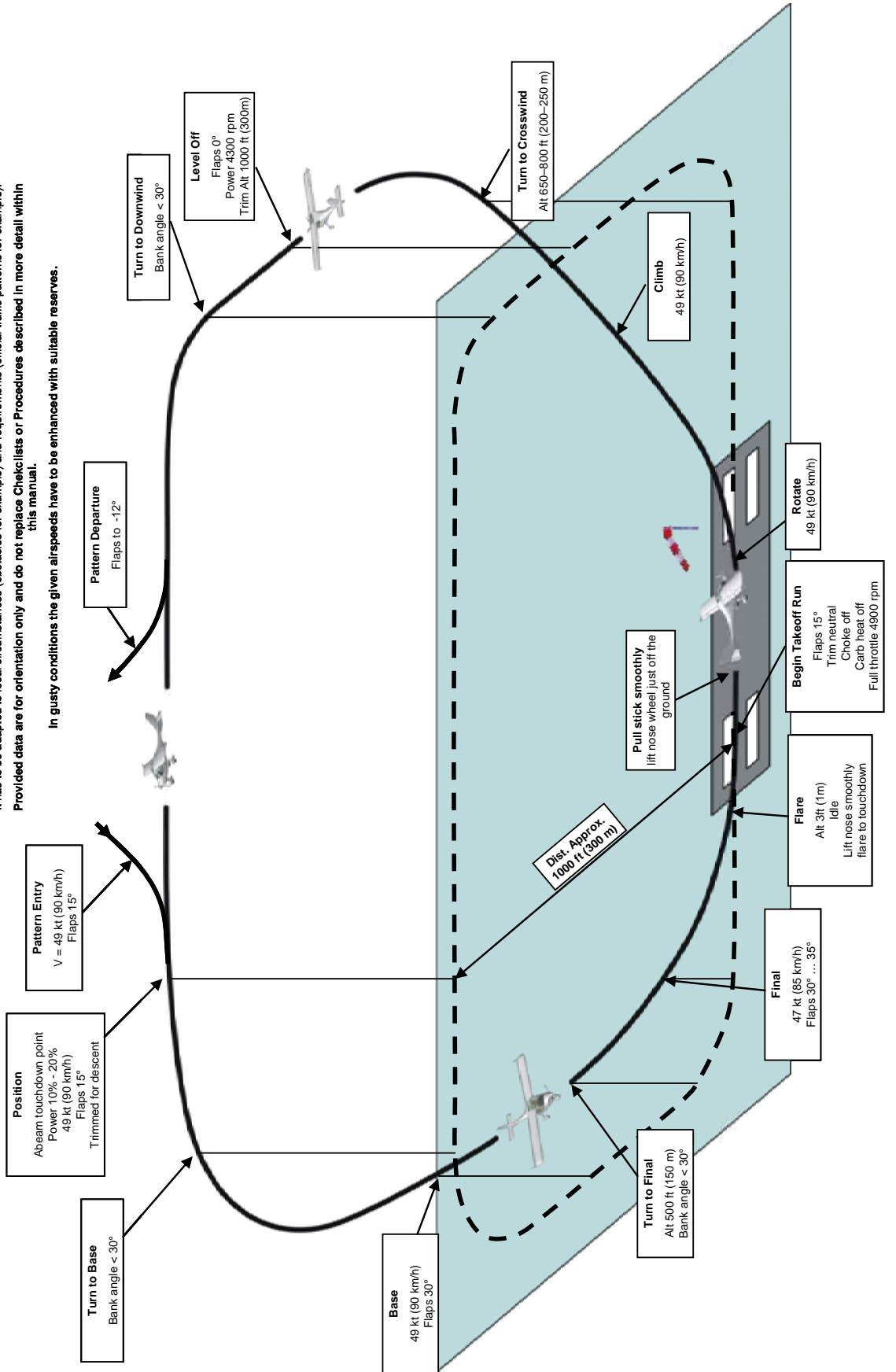

### 4.8. Take-off and climb

The airfoil of the MC offers good climb characteristics, even in the cruise-optimized flap position. Normally on short runways, the flaps are set to 15° for take-off. On hard surface runways, however, take-off is more efficient with the flaps set to 0°. This setting can also be used for a closed circuit as it reduces the pilot workload as the flaps need not be reset until abeam the touchdown point. Performance data and speeds for 0° flaps are provided in chapter 5.

During the take-off roll, engine rpm should be checked after full throttle has been applied. Indicated engine rpm should be about 4900 RPM. Only when the engine has reached this speed is the correct take-off power available.

In order to be able to hold direction on the runway, the MC pilot must look for an appropriate reference point. Pilots used to flying other types of aircraft are often confused by the strongly tapered fuselage nose of the MC, tending to take-off and land with a lot of sideslip. The pilot's view straight ahead is very much to the left. At first this appears to be far too far to the left, but it is indeed correct. The point can be located by drawing a vertical line upwards from the between the rudder pedals.



View from the pilot's seat; line indicates looking straight ahead.

As soon as the aircraft starts to accelerate, the stick should be pulled back slightly to unload the nose wheel. The aircraft takes off faster when the nose wheel is slightly lifted. When airborne, relax the aft pressure slightly to increase speed to best rate-of-climb speed (100 km/h – 54 kts with wing flaps +15°; 113 km/h – 61 kts with wing flaps 0°; both at takeoff weight of 1320 lbs – 600 kg).

**Warning:** Climbing at speeds below the recommended rate-of-climb speed does not bring any advantages as the aircraft will not climb as steeply when it is flying below the best angle-of-climb speed. With decreasing speed, the aircraft also becomes more difficult to control. These circumstances should be brought to mind when taking off from a short runway with obstacles.

Wing flap settings may be adjusted once a safe altitude of 50 m (164 ft) has been reached. The MC climbs at a better rate and a better angle with the flaps retracted to 0°. It is



## Aircraft Operating Instructions (AOI)

Type: *MC*

Series: *MC-LSA*

Page: 4-13

recommended that once as airspeed of 105 km/h (57 kts) is exceeded to retract the flaps from 15° to 0°. The climb can then be continued at 113 km/h (61 kts). When this speed is exceeded, the flaps can be further adjusted to -12°. The aircraft can then climb further and efficiently at 125 km/h (67 kts).

**Warning:** When adjusting the flaps to the negative position, the drag and lift co-efficient of the airfoil are reduced for the same angle of incidence. The aircraft must thus be accelerated during flap retraction. As a result, climb rate drops initially before it then picks up again. When retracting the flaps in horizontal flight, the aircraft can sink slightly. Therefore, the flaps should never be moved in the negative direction near the ground!



## Aircraft Operating Instructions (AOI)

Type: *MC*

Series: *MC*-LSA

Page: 4-14

### 4.9. Cruise

Normal cruise is performed with the flaps set at  $-12^\circ$ . The airfoil offers the lowest drag in this setting and fuselage airflow is the most favorable. This is immediately apparent when the flaps are adjusted to this setting - the aircraft accelerates markedly.

The ground adjustable propeller installed in the MC is set by the manufacturer to ensure that maximum continuous power (5500 RPM) cannot be exceeded in horizontal cruise with full throttle. Despite this, attention should be paid to this limitation as climatic variations (temperature, air pressure) can lead to it being marginally exceeded.

Efficient cruise performance is achieved at about 4800 - 5000 RPM. Greater rpm means greater airspeeds but this can only be achieved at the expense of much higher fuel consumption. The greatest range is achieved at the relatively low value of 4300 RPM.

The carburetor heat lever should be pulled out if there is a risk of carburetor icing. Once ice has accumulated it takes more than a few seconds for it to be removed. Carburetor heat must be left on for a long time. However, carburetor heat should not be kept on continuously as this leads to an enriching of the air/fuel mixture in the engine and can lead to fouling of the spark plugs which, in turn, adversely affects the smooth running of the engine and performance.

**Warning:** Never put on carburetor heat during take-off and climb as carburetor heat reduces engine performance.

During cruise, fuel consumption should be monitored closely. The Dynon EMS (if installed) shows current consumption, total consumption since take-off and remaining fuel quantity.

**Warning:** In order to achieve an accurate indication of fuel consumption using the Dynon EMS, the correct amount of fuel available must be programmed before take-off. Otherwise the values shown are not reliable. It is thus recommended that you do not rely on values programmed by someone else.

Fuel quantity should also be continuously monitored during flight by checking the fuel tank indicators in the wing roots. Despite their simplicity, they represent clear information about the fuel load in the tanks, particularly as fuel the level drops.

**Warning:** A correct indication on the fuel quantity tubes in the wing ribs is only possible when the wings are completely level.

**Warning:** There is a tendency to fly the MC with a small sideslip angle. Flight performance is only marginally affected but it can lead to the tanks emptying at different rates. In this case, it is recommended that the wing with the fuller tank be raised in a gentle slip temporarily. The aircraft should be returned to level flight after a few minutes and the fuel indication checked. The amount in the tanks should now be more even.

**Warning:** The tanks in the MC have return flow flapper valves on the fuel tank anti-sloshing rib (refer to Chapter 7 Systems description). They prevent fuel from quickly flowing into the outer tank area during side slipping where it could not be fed into the engine. The return flow valve reduces but does not completely prevent return flow. An exact indication of fuel quantity is thus only possible at the wing root when, after a sideslip, the aircraft has returned to normal





## Aircraft Operating Instructions (AOI)

Type: *MC*

Series: *MC-LSA*

Page: 4-15

flight attitude (and the amount of fuel inside and outside the anti-sloshing rib has evened out).

### **4.10. Turns**

Each heading change is flown coordinated in the MC with aileron and rudder. The horizon is held level with the stabilizer. Maximum permissible airspeed (dependent upon the ballistic recovery system) should never be exceeded. Steep turns should not be flown, particularly at low altitudes.

At low speeds in tight turns the aircraft loses altitude rapidly. Turns with more than 30° bank should, therefore, not be flown below an airspeed of 100 km/h (54 kts). Should one of the wings drop and the aircraft go into a spin because of too low airspeed and crossed controls, it can be easily recovered. Refer to the relevant emergency procedures in Chapter 3.





## Aircraft Operating Instructions (AOI)

Type: *MC*

Series: *MC*-LSA

Page: 4-16

### 4.11. Stall

Stalling speed for the MC with a weight of 600 kg (1320 lbs) is 67 km/h (36 kcas) with the flaps set at 35°, 78 km/h (42 kcas) with the flaps retracted to 0° and 87 km/h (47 kcas) with flaps in fast cruise -12°. Approaching stall is indicated by a sluggishness around the vertical axis. The controls become "soft" about 5 km/h (3 kts) above stall speed. Release the aft pressure on the stick to increase airspeed. Close to stall the aircraft can only be controlled by rudder and stabilizer. In a stall, the effectiveness of the ailerons is greatly reduced.

When the nose drops during a stall, the aircraft will lose approx. 50 m (164 ft) altitude. Thus, near the ground a safety minimum speed of approx. 115 km/h (62 kts) should be maintained.

### 4.12. Approach and landing

When possible, an aircraft should land into the wind. Final approach should be flown in a straight line extending in the direction of the runways and begun at sufficient altitude.

**Warning:** A stable final approach is important for a successful landing. If the landing configuration is taken up in good time and at a sufficiently high altitude, the pilot's work load may be reduced considerably. With the aircraft flying stably it can be more easily controlled down to touch-down. Too high approach speeds with flap changes shortly before touch-down lead very quickly to dynamic flight conditions which are very stressful for the pilot. If in doubt: abandon the approach and perform a go around. This is always better than taking a chance of damaging the aircraft due to a hard landing.

Some power (10 – 20 %) should be maintained during approach. This makes it easier to determine that the engine is running properly and is able to provide full power, if required. The slightly increased pressure on the empennage also has a positive effect on controllability and control feel.

If there is a risk of carburetor icing, the carburetor heat should be pulled on during the approach. It should, however, be pushed off in short finals so that full engine power is available, should a go-around be necessary.

Approach the ground with constant power setting. About a meter (3 ft) above the ground, retard the throttle completely and smoothly flare the aircraft.

A somewhat higher approach speed should be used for landings in a crosswind to ensure that the aircraft remains controllable. In addition, it is also recommended that the wing flaps be set at maximum 15° or even 0° when landing in a crosswind. Be mentally prepared to perform a missed approach - go around if needed.

During a landing with crosswind, the upwind wing should be dipped by applying aileron against the wind and direction kept using the rudder. As the MC is a high-wing airplane, there is no risk of the wing tips touching the ground. .

**Warning:** Do not rely on the demonstrated wind speed data in the manual for crosswind landings. Local conditions can lead to lower limits. For example, hangars are often found at right angles to the touch-down point, causing dangerous leeward turbulence which cannot be avoided.



## Aircraft Operating Instructions (AOI)

Type: *MC*

Series: *MC-LSA*

Page: 4-17

**Warning:** The aircraft can be landed with ease and safely with flaps set at 15°. A landing with flaps set at 0° or even -12° is possible. The maximum positive flap deflection (35°) should be used to land on very short runways (less than 1000ft) under favorable wind condition (no crosswind component, very light wind and low gusts). Landing with flaps set at 35° requires a lot of practice and should be trained with an experienced flight instructor familiar with the MC. The increased flap deflection does not reduce the attainable minimum speed, it does, however, greatly increase drag. This permits very short landings but can also create a rapid loss of speed during the landing flare. Flaring too high above the ground will cause the aircraft to drop. In this case, apply full power immediately for a go-around and a new approach. A go-around initiated with full flaps is not a problem for the MC. It is, however, recommended not to use full flaps when landing in a crosswind.

After landing, all unnecessary electrical equipment, especially the landing light, should be switched off. As this equipment requires a lot of power and since the alternator does not produce much power during taxiing due to relatively low engine rpm, the battery would discharge considerably before the engine is finally shut down.



## Aircraft Operating Instructions (AOI)

Type: *MC*

Series: *MC*-LSA

Page: 4-18

### **4.13. Shutting down the engine**

Under normal conditions, the engine cools sufficiently during descent and taxiing that it may be shut down by switching off the ignition. All electrical equipment along with the alternator should be switched off before the engine is shut down in order to protect the equipment from damage caused by a voltage spike. The Dynon EFIS and the Garmin 496 have back-up batteries which are activated if the aircraft power system fails or is switched off. These instruments are, therefore, still active when the power supply is switched off. Since they are independent from the aircraft power system, no damage can occur when the engine is shut down.

### **4.14. Checking the emergency location transmitter (ELT)**

After every landing and, especially, after parking the aircraft, the ELT should be checked for accidental deployment. Under certain unfavorable circumstances, a hard landing can result in the activation of the ELT. It has also been known for the ELT to be switched on accidentally by hand during loading or unloading.

A false alarm can be simply detected by listening to the international emergency frequency 121.5 MHz on the COM radio. An active ELT is also shown on the remote control unit in the lower instrument panel.



## Aircraft Operating Instructions (AOI)

Type: **MC**

Series: **MC-LSA**

Page: 5-1

### 5. PERFORMANCE

Performance data is based on an aircraft in good condition and correct settings. Even the smallest adjustments to the controls or the omission of a small piece of fairing can adversely affect aircraft performance. Sufficient reserve should be added to the data given in this handbook to cover all such possibilities.

#### 5.1. Performance data for MTOW @ 600 kg (1320 lbs)

**Warning:** All performance data are based on standard atmosphere at sea-level and the Neuform CR3-65-47-101.6 propeller. They are also based on the procedures described in this instruction. Higher runway elevations, higher temperatures and other propellers can lead to considerable differences in the data!

Takeoff distances in different conditions	Mowed, level, dry grass runway or pavement
	<small>Note: These two surface types, both in good condition, do not make a noticeable difference on this aircraft</small>
... with flaps 15°	Take-off roll 190 m (625 ft.)
	... distance to clear 50 ft. obstacle 300 m (985 ft.)
	... at take-off speed 90 km/h (49 kts CAS)
... with flaps 0°	Take-off roll 260 m (850 ft.)
	... distance to clear 50 ft. obstacle 450 m (1475 ft.)
	... at take-off speed 105 km/h (57 kts CAS)
... with flaps -12°	Take-off roll 320 m (1050 ft.)
	... distance to clear 50 ft. obstacle 540 m (1775 ft.)
	... at take-off speed 115 km/h (62 kts CAS)

Note: Takeoff with flaps negative is not recommended, but values shown for completeness.

Best rate-of-climb	flaps 15°	100 km/h (54 kts CAS)
		4.2 m/s (830 ft/min)
	flaps 0°	113 km/h (61 kts CAS)
		4.3 m/s (850 ft/min)
	flaps -12°	124 km/h (67 kts CAS)
		4.0 m/s (790 ft/min)

Best angle-of-climb	flaps 15°	90 km/h (48 kts CAS)
		approx. 6:1 (18°)
	flaps 0°	102 km/h (55 kts CAS)
		approx. 6.5:1 (16.5°)
	flaps -12°	113 km/h (61 kts CAS)
		approx. 8:1 (14°)

Note:

6:1 means: Fly 6 ft to climb 1 ft. Means 8:1 is less steep than 6:1!

Maximum level speed VH	flaps -12°	195 km/h (105 kts CAS)
		@ 5500 rpm

Typical cruise performance point	flaps -12°	175 km/h (95 kts TAS)
... engine setting and density altitude	@ 5000 rpm, 24.8 in Hg,	@ 4500 ft D-Alt



## Aircraft Operating Instructions (AOI)

Type: *MC*

Series: *MC*-LSA

Page: 5-2

... consumption, endurance, range

5,0 US Gal/h, 4,8 hrs, 850 km (455 Nm)

Note: includes 30 min reserve

Maximum range

1150 km

(640 NM)

150 km/h IAS

(80 kts CAS)

flaps -12°; @ 4300 rpm

### 5.2. *Flight altitude and density altitude*

In order to determine exactly the aircraft performance available for a particular flight, the density altitude must be calculated. The MC is equipped with a carbureted engine, the performance of which varies according to ambient temperature and pressure. This is the reason that density altitude is so important. The aerodynamic characteristics of the aircraft are also dependent upon this parameter.

Density altitudes can easily be calculated using the chart below. Using this density altitude as the input parameter, the performance which can truly be expected will be calculated in the following sections.

An example is given in this diagram. Outside air temperature is -10°C (14° F.) and the altimeter shows a (pressure) altitude of 8000ft.

**Warning:** pressure altitude can be obtained with the reference pressure of the altimeter set to standard atmosphere = 1013.25 hPa (=29.92 in Hg) only.

The corresponding density altitude is 2100 m (6885 ft.). Performance values are thus equivalent to those given in the next chapter for 2100 m. If the pressure altitude of 2400 m (7868 ft) were used, the performance figures would be wrong. This difference can be very significant, particularly in the summer months when the density altitude is much higher than the pressure altitude due to the higher temperatures.



# Aircraft Operating Instructions (AOI)

Type: *MC*

Series: *MC*-LSA

Page: 5-3

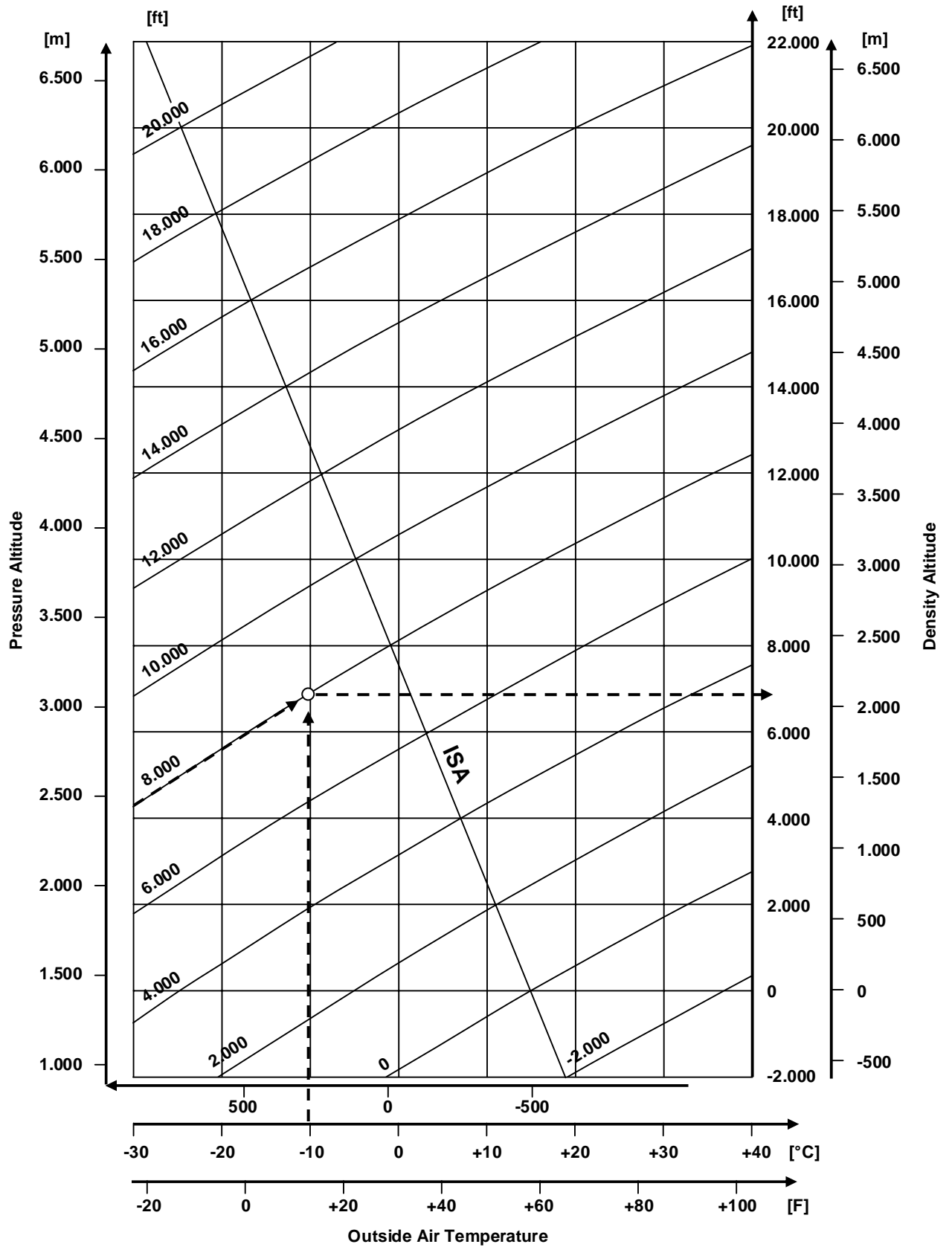

### 5.3. Significance of the wind component

Wind directly affects the flight path and thus aircraft performance. Two diagrams are presented below which show the significance of the wind component.

#### 5.3.1. Wind influence on take-off roll and landing

To determine whether the aircraft can take-off safely, it is necessary to determine the prevailing crosswind component. On the one hand, this determines the appropriate take-off procedure while, on the other hand, it ensures that the demonstrated permissible crosswind component for take-off and landing is not exceeded. The following diagram is used to determine the crosswind component.

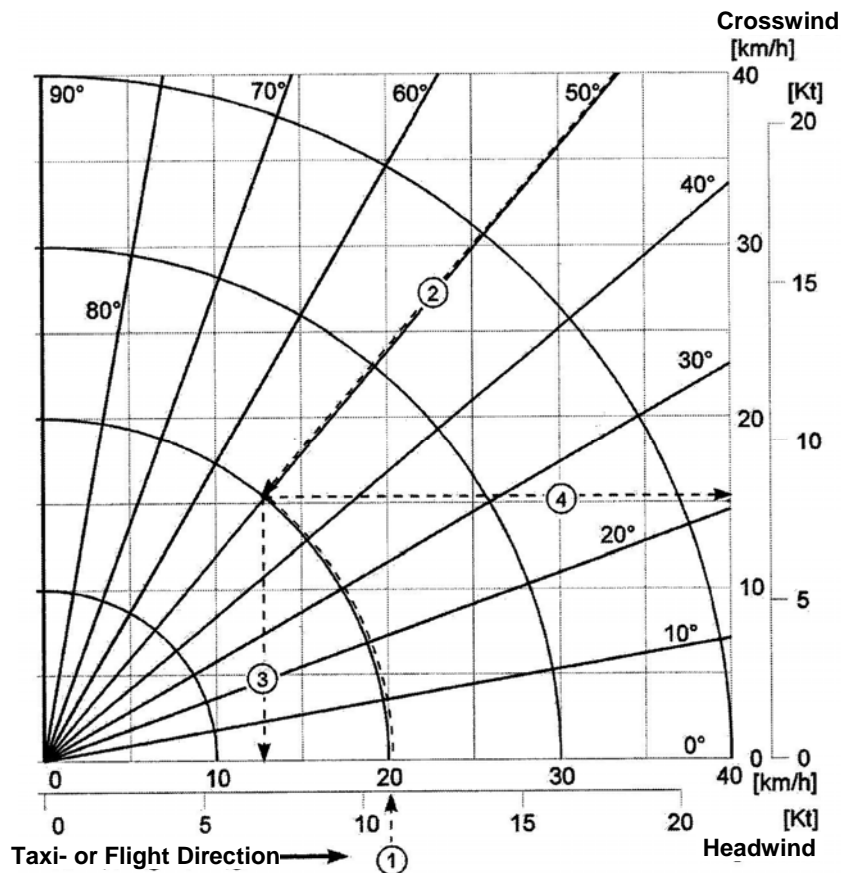

An example is shown in the diagram. Take-off direction is 120°. The wind direction is 70°, wind speed 11 kts. The wind angle is thus  $120^\circ - 70^\circ = 50^\circ$ . Wind speed is plotted along the circle segment (1) to the point where it intersects the wind angle (2). The corresponding value on the x-axis (3) results in a headwind component of 7.1 kts, the value on the y-axis (4) in a crosswind component of 8.4 kts.

Values for landing are determined in a similar manner.



### 5.3.2. Wind influence on cruise

Wind also has a noticeable influence on the forward progress of the aircraft over ground in cruise. The relevant components can be easily calculated from the graph.

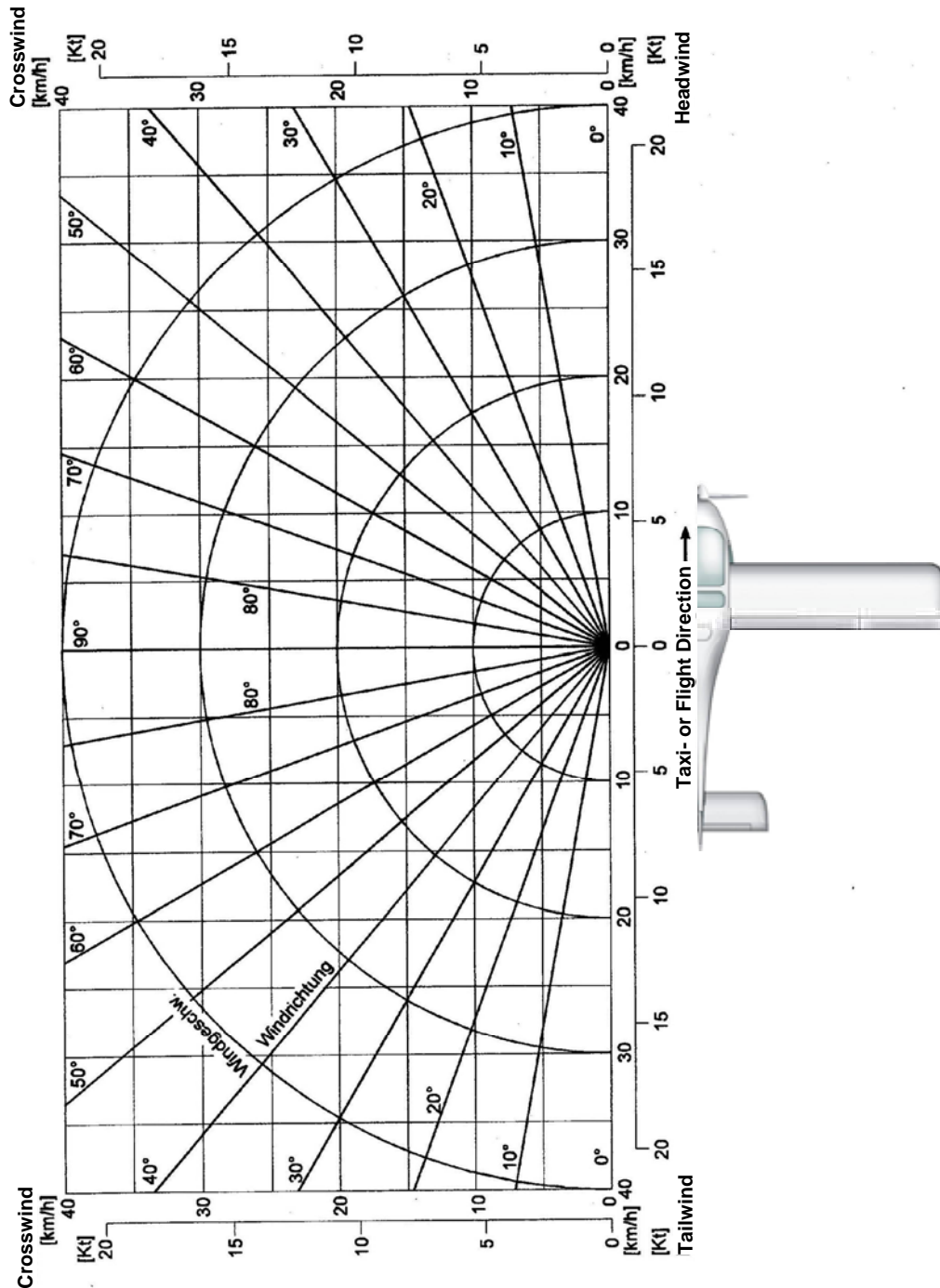

Calculation procedures are analogous to those used to determine take-off procedures, the only difference being the possible inclusion of a tailwind component.



#### 5.4. Engine performance subject to altitude

Engine performance decreases with increasing (density) altitude. The following data may be used to determine available engine performance. The data show the engine power with fully opened throttle and at different engine rpm.

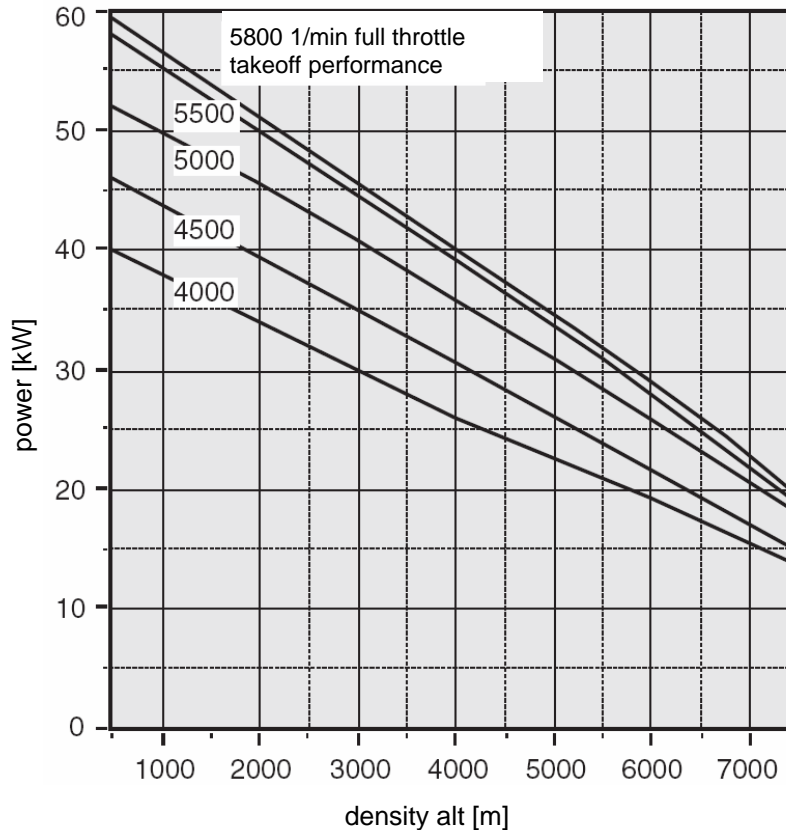

#### 5.5. Calculating the take-off distance

Takeoff distances in the following charts have been analyzed for varying conditions and takeoff weights using FAA approved analysis methods.

**Warning:** Important for the usage of these charts is again the correct density altitude. Field elevation is not sufficient, as this does neither consider local day air pressure nor local temperature. Both have noticeable effect to the takeoff performance.

**Warning:** Don't forget that these are handbook methods which, in practice, are heavily dependent upon many factors and in particular from the way the take-off is actually performed. The values are based on an aircraft in good conditions piloted by an experienced pilot. Always add a reserve to the data which takes into consideration the local conditions and your level of piloting experience.



## 5.5.1. Take-off distance charts

The take-off roll distance defines the distance between the begin of the take-off roll and the point where the aircraft leaves the ground. This distance is given for concrete without inclination and without wind influence. Distances for short mown grass on a hard and dry level soil are comparable with the MC.

### 5.5.1.1. Charts for flaps setting 0°

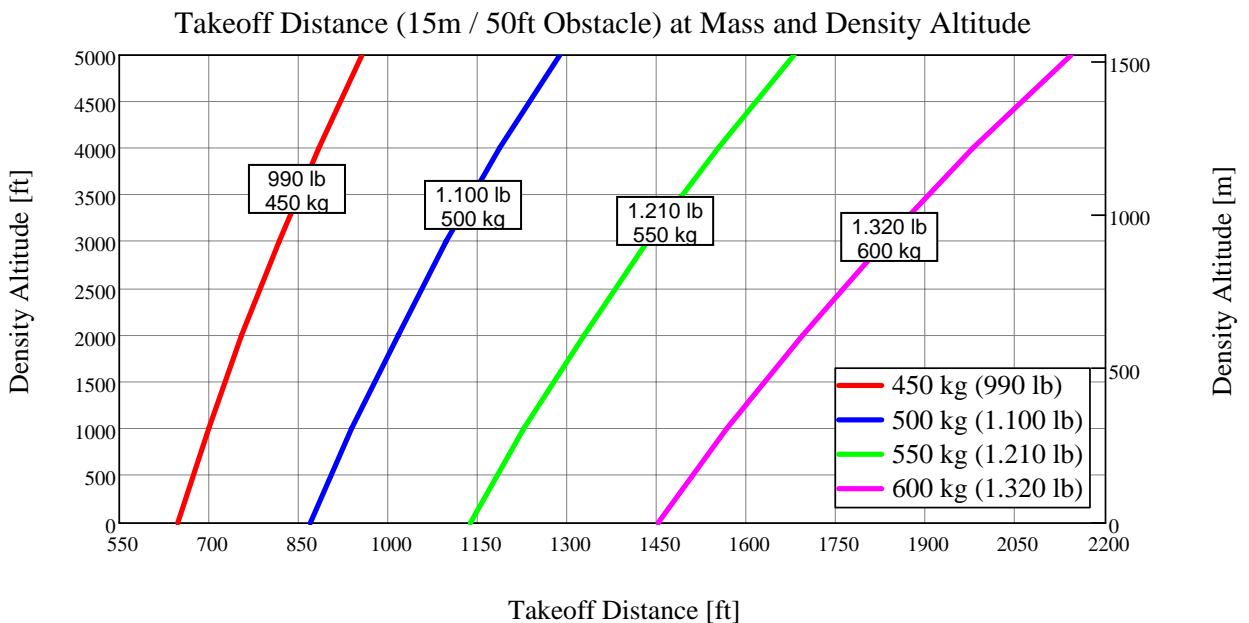
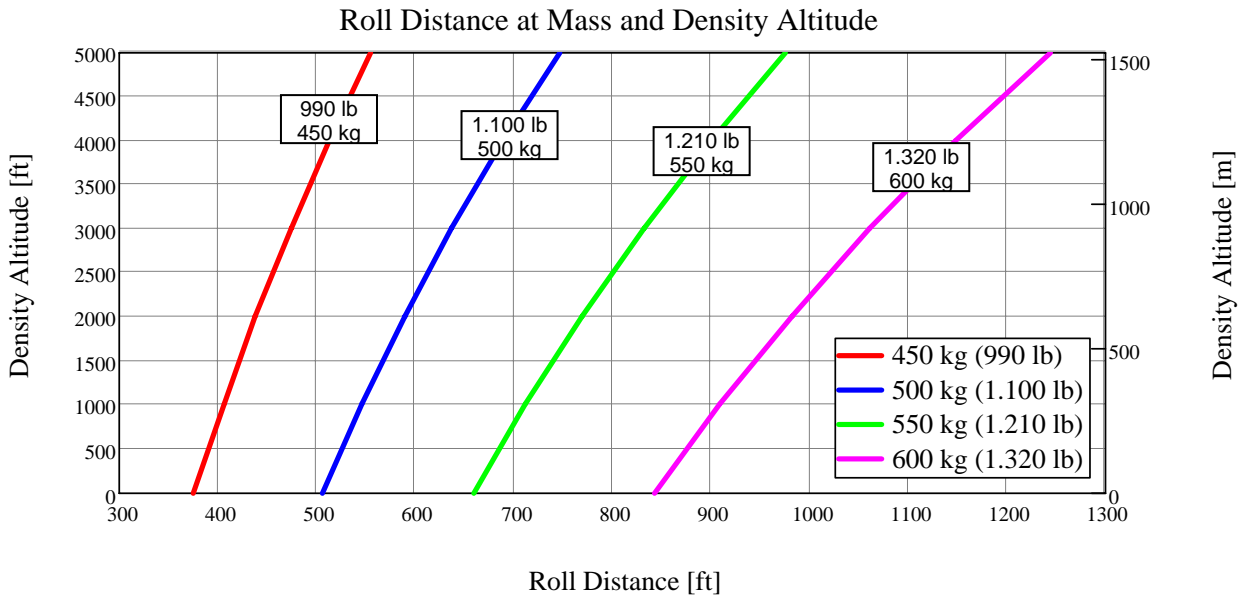



# Aircraft Operating Instructions (AOI)

Type: **MC**

Series: **MC-LSA**

Page: 5-8

## 5.5.1.2. Charts for flaps setting 15°

### Roll Distance at Mass and Density Altitude

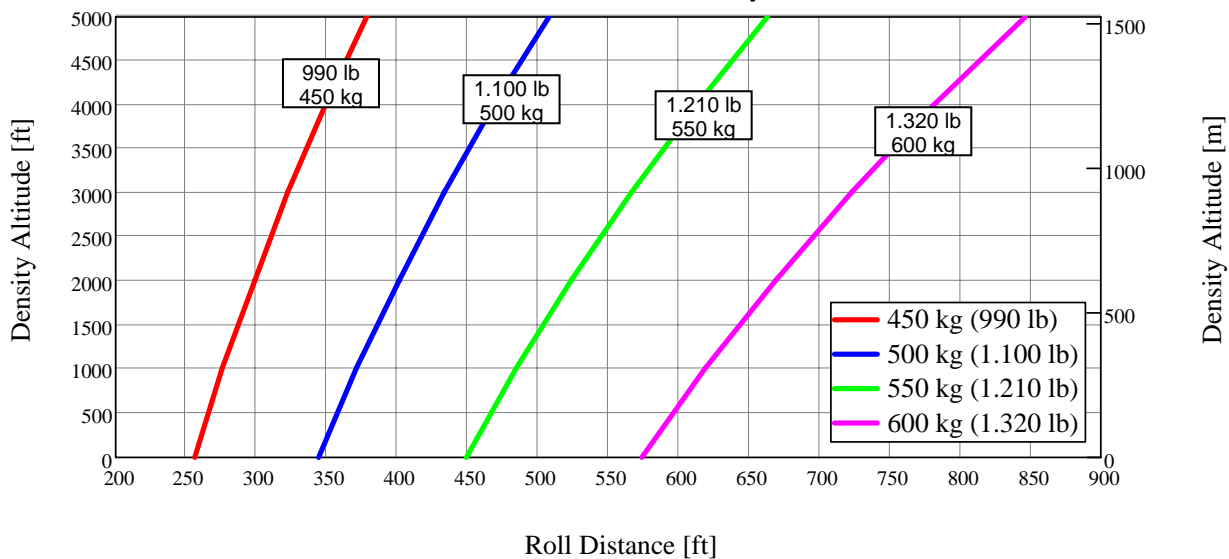

### Takeoff Distance (15m / 50ft Obstacle) at Mass and Density Altitude

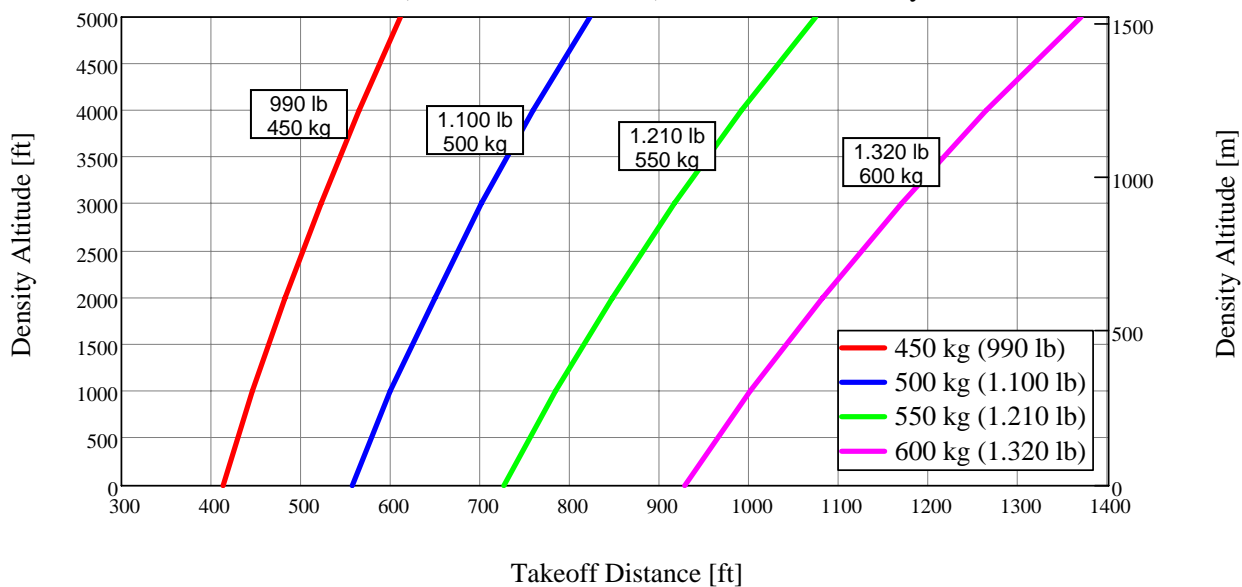



## Aircraft Operating Instructions (AOI)

Type: *MC*

Series: *MC*-LSA

Page: 5-9

### 5.5.2. Influences to take-off distance

Take-off performance for conditions different to the ones named before can be estimated by using the following rules of thumb. Again the basis is an aircraft in good condition and a well trained pilot.

Influence	Increase of take-off roll distance	Increase of take-off distance
high grass 8 in (20cm)	app. 20% (= x 1.2 )	app. 17% (= x 1.17 )
Flaps 0° instead of 15°	app. 10% (= x 1.1 )	app. 20% (= x 1.2 )
2% inclination of runway	app. 10% (= x 1.1 )	app. 10% (= x 1.1 )
4% inclination of runway	app. 14% (= x 1.14 )	app. 12% (= x 1.12 )
tail wind 5 kts	app. 20% (= x 1.2 )	app. 25% (= x 1.25 )
wet snow	app. 30% (= x 1.3 )	n/a
soaked soil (1.2 in (3cm) deep)	app. 16 % (= x 1.16 )	n/a

Each factor occurring at a time has to be considered individually.

Example: Takeoff at 500 kg (1 100 lb) at 20°C (68 F) at 600 m (2000 ft) pressure altitude in high grass with a runway 2% inclination. As by chapter 5.2 density altitude for this case is 900m (3000 ft). Takeoff charts show a take-off roll distance of 190 m (620 ft) and a take-off distance of 340 m (1120 ft).

Consideration of the deviating factors delivers: Take-off roll = 620 ft x 1.2 x 1.1 = 820 ft (250 m) and Take-off distance = 1120 ft x 1.17 x 1.1 = 1 440 ft (440 m).



## Aircraft Operating Instructions (AOI)

Type: *MC*

Series: *MC*-LSA

Page: 5-10

### 5.6. Calculating climb performance

The aircraft is nearly always operated under different conditions than ISA standard atmosphere. Aircraft climb performance under different conditions can be estimated according to the following tables. The basis for these values is an aircraft in good conditions. Best climb is achieved with 0° flaps. Data are provided for -12°, 0° and 15° flaps (cruise, climb and take-off condition).

**Warning:** Knowledge of the correct density altitude is mandatory to obtain reliable values for the aircraft performance.

Climb performance at flaps -12°, Aircraft weight 600 kg (1320 lbs)

density alt [ft]	rate of climb [ft/min]	rate of climb [m/s]	rate of climb at CAS [kts / km/h]
0	790	4.0	70 / 130
5.000	460	2.3	70 / 130
10.000	160	0.8	71 / 132
12.000	70	0.4	71 / 132

Climb performance at flaps 0°, Aircraft weight 600 kg (1320 lbs)

density alt [ft]	rate of climb [ft/min]	rate of climb [m/s]	rate of climb at CAS [kts / km/h]
0	850	4.3	59 / 109
5.000	520	2.6	60 / 111
10.000	220	1.1	61 / 113
12.000	120	0.6	61 / 113

Climb performance at flaps 15°, Aircraft weight 600 kg (1320 lbs)

density alt [ft]	rate of climb [ft/min]	rate of climb [m/s]	rate of climb at CAS [kts / km/h]
0	830	4.2	54 / 100
5.000	500	2.5	54 / 100
10.000	190	1.0	54 / 100
12.000	105	0.5	55 / 102

## 5.7. Gliding characteristics

The following chart shows the distances the aircraft can glide, dependent upon altitude, assuming smooth air, no wind and no vertical air currents.

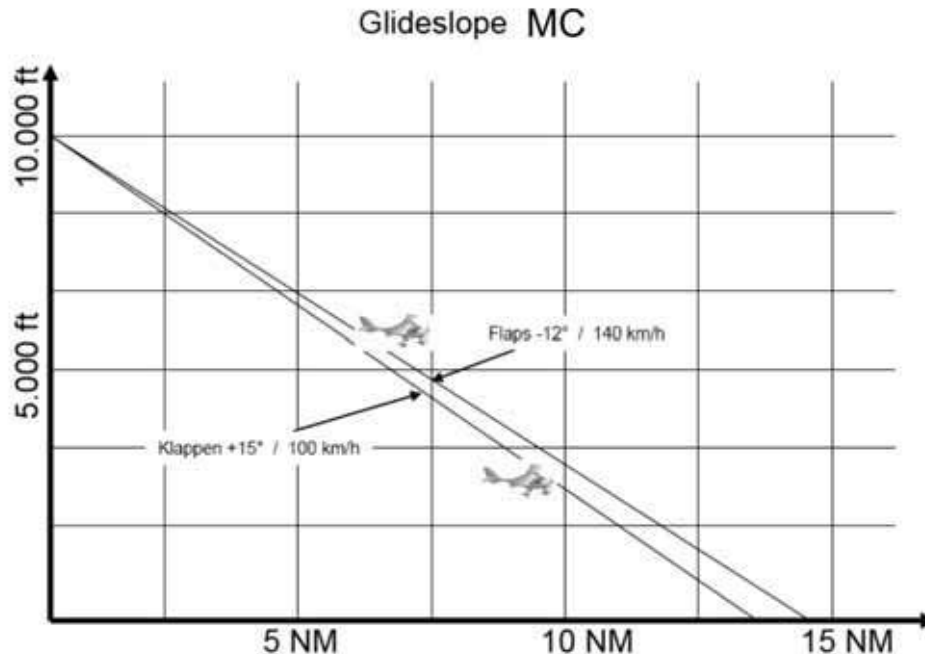

**Warning:** Intensive thermal activity can prolong these distances. Turbulence, however, usually leads to a reduction in gliding distance. One should never expect favorable conditions when estimating a possible gliding distance!

Glide angle of the MC can be assumed in practice to be 8 to 1. With flaps extended this ratio gets worse. One effect of moderately set flaps is to reduce the minimum sink, but the speed at which the minimum sink is observed reduces faster. This results in a reduced possible gliding distance. Speeds for best glide at flight mass and negative flaps can be assumed as follows:

600 kg (1320 lbs)	140 km/h (78 kts)
500 kg (1100 lbs)	124 km/h (67 kts)
400 kg (880 lbs)	115 km/h (62 kts)



## Aircraft Operating Instructions (AOI)

Type: *MC*

Series: *MC*-LSA

Page: 6-1

### 6. WEIGHT AND BALANCE, AND EQUIPMENT LIST

#### 6.1. Weight Limits

The following limits ensure the safe operation of the aircraft:

Maximum take-off weight (MTOM)	600 kg (1320 lbs) max according to national laws and certification requirements lower limits may exist
Minimum crew weight	54 kg (119 lbs)
Maximum load per seat	130 kg (286 lbs)
Maximum baggage load, total but per side limited to max.	2 x 25 kg (55 lbs) = 50 kg (110 lbs) 25 kg (55 lbs)
Center of gravity range:	<del>318 – 458 mm*(12.5 inches – 18.0 inches)</del> 318 – 392 mm* (12.5 in – 15.4 in) **

\* Reference datum is the wing leading edge with the aircraft in the neutral position. Refer to Chapter 6 "Weight and Balance".

\*\* Design rear cg limit is 458 mm / 18.0 in. Out of safety reasons at this point in time rear flight cg range limited (flight tests not fully completed for most rear cg position)

#### 6.2. Weighing

To weigh the aircraft, three scales must be set on a level floor. The aircraft is leveled by shimming either the nose wheel or both of the main wheels. It is in the correct position for weighing when the tunnel (where the throttle quadrant is located) in the cockpit is in the horizontal position. The aircraft must also be level spanwise. This can be determined by placing a level on the tube that crosses the cabin between the forward wing attachment points, above the instrument panel.

Using a plumb bob, the middle of the wheel axles is projected on to the floor and marked. The same procedure is used to mark the reference datum. A plumb bob is dropped from the wing leading edge on the outer side of the root rib. The distance between the wheels must be measured during each weighing. These values must then be used in the tabulation. If the original Flight Design weighing form is used as a spread sheet, the distances must be recorded with a positive algebraic sign. If the calculations are done manually, one must be careful to use the proper algebraic signs.

It is easy to make mistakes when weighing, particularly if the scales are interfered with by a side-load (e.g. due to landing gear strut compression). It is therefore very important that the weighing process remains free from distortion. Distortion can be avoided if at least one of the main wheels (better both) is placed on a pair of metal plates with grease in between. The two plates slide easily on each other which reduces the tension due to side-loads virtually to zero.

An example of a weighing record is given below. The weighing data for the aircraft as delivered from the factory is to be found in this Pilot's Operating Handbook and Maintenance Manual. It is the responsibility of the owner of the aircraft to ensure that the aircraft is weighed after any relevant changes (change in equipment; repair work). Furthermore it is mandatory that the main mass data be recorded on the relevant page of the Aircraft Operational Instruction. .



## Weight and Balance of LSA Aircraft

Type:	MC
Model:	MC
Production Number:	A-09-01-31
Engine Number:	5651080
Equipment list with date:	01.Mar.09
Grey fields require inputs	

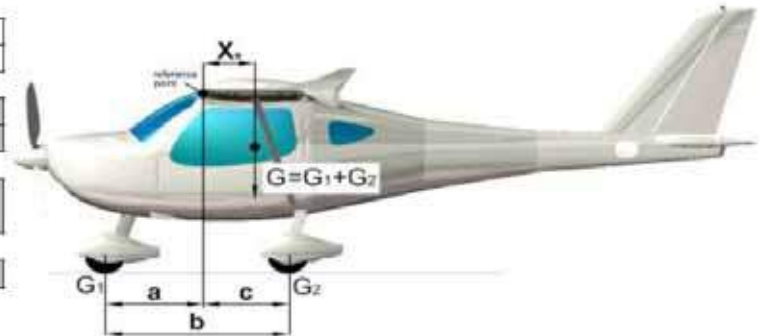

Reference Point:	Wing leading edge	Ref. Plane:	Tunnel roof in cabin horizontal
------------------	-------------------	-------------	---------------------------------

### Weighing and Empty Aircraft cg

Support point	Gross weight	Tare	Net weight	Distance to ref	Moment
Nose wheel	78.00 kg	0.00 kg	78.00 kg	0.830 m	-64.7 kg*m
Main wheels	297.60 kg	0.00 kg	297.60 kg	0.635 m	189.0 kg*m

Deductions					
Fuel		0 l	0.00 kg	0.210 m	0.0 kg*m

<b>Empty Weight and cg</b>			<b>375.60 kg</b>	<b>0.331 m</b>	<b>124.2 kg*m</b>
----------------------------	--	--	------------------	----------------	-------------------

Component weight	
Wing left	37.40 kg
Wing right	37.90 kg
Stabilizer+elevator	9.80 kg
Rudder	2.05 kg
Fuselage	288.45 kg
Control sum	375.60 kg
<b>Weight of non-lifting parts</b>	<b>300.30 kg</b>

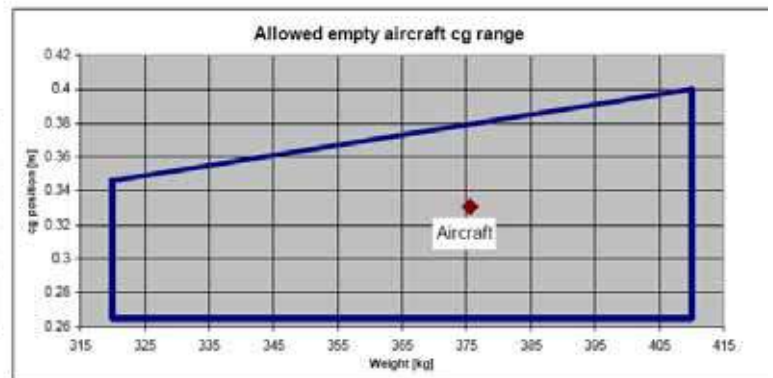

### Summary:

Certification Basis	
MTOW	600.00 kg
Max weight of non-lifting parts	519.00 kg

Data of Aircraft	
Empty weight	375.60 kg
Max payload	224.40 kg
Max pl. fuselage	218.70 kg

L'anzberg  
Signature

Kherson, Ukraine  
City

01.Mar.09  
Date



## Weight and Balance of LSA Aircraft

Type:	MC
Model:	MC
Production Number:	A-09-01-31
Engine Number:	5651080
Equipment list with date:	01.Mar.09
Grey fields require inputs	

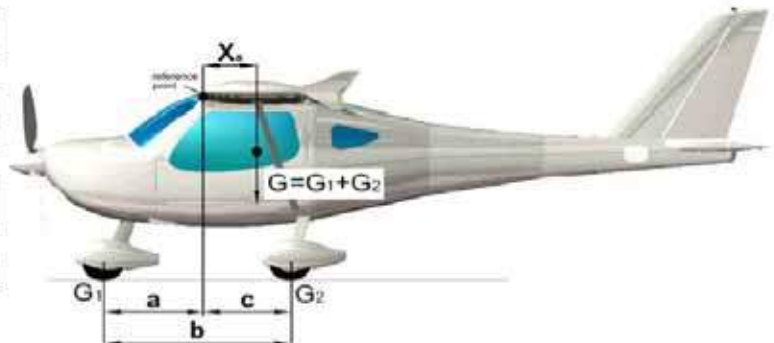

Datum Point:	Wing leading edge	Datum Plane:	Tunnel roof in cabin horizontal
--------------	-------------------	--------------	---------------------------------

### Scaling and Empty Aircraft cg

Support point	Gross weight	Tara	Net weight	Distance to ref	Moment
Nose wheel	171.96 lb	0.00 lb	171.96 lb	32.7 in	-5619 lb*in
Main wheels	656.08 lb	0.00 lb	656.08 lb	25.0 in	16402 lb*in

Deductions					
Fuel		0 gal	0.00 lb	8.3 in	0 lb*in

<b>Empty Weight and cg</b>	<b>828.04 lb</b>	<b>13.0 in</b>	<b>10783 lb*in</b>
----------------------------	------------------	----------------	--------------------

Component weight	
Wing left	82.45 lb
Wing right	83.55 lb
Stabilizer	21.60 lb
Rudder	4.52 lb
Fuselage	635.91 lb
Control sum	828.04 lb
<b>Weight of non-lifting parts</b>	<b>700.62 lb</b>

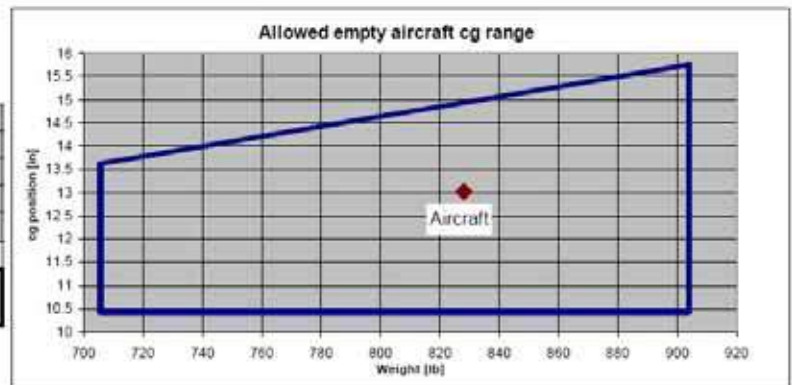

### Summary:

Certification Basis	
MTOW	1320.00 lb
Max weight of non-lifting parts	1144.18 lb

Data of Aircraft	
Empty weight	828.04 lb
Max payload	494.71 lb
Max pl. fuselage	482.14 lb

L'anzberg  
Signature

Kherson, Ukraine  
City

01.Mar.09  
Date



## Aircraft Operating Instructions (AOI)

Type: *MC*

Series: *MC*-LSA

Page: 6-4

**Warning:** The empty weight data in this example does not correspond to an actual aircraft. Use only the empty weight and center of gravity data from the most current weight record of your specific aircraft!

The weighing record provides an insight into the state of the aircraft at the time of weighing. The MTOW as defined by the certification regulations and the maximum weight of the aircraft as defined for structural proofs are used to calculate the maximum permissible payload and the maximum payload in the fuselage. A diagram in the weighing form gives information about the position of the empty weight center of gravity. The aircraft is designed to make it impossible for the permissible center of gravity to be exceeded when the aircraft has been loaded within the limits set down in this handbook and the empty weight is within the specified range. If necessary, trim ballast weight should be installed to remain in the permissible empty weight cg range.

The weighing record is only valid in connection with the current equipment list. Any changes to the aircraft must be appropriately registered. It is also possible that national regulations require weighing to be carried out at specified intervals or after specified work on the aircraft. It is the responsibility of the owner to conform to such national requirements.

The aircraft is operated in different countries under different certification regulations. There is also a wide variety of options available for the aircraft, some of which may not be installed in some countries. A variety of these options can also lead to an increase in aircraft empty weight which exceeds that set down in the certification regulations of some countries. It is the responsibility of the owner to ensure that national regulations concerning aircraft specification and operation are followed.



## Aircraft Operating Instructions (AOI)

Type: **MC**

Series: **MC-LSA**

Page: 6-5

### 6.3. Flight Mass and Center of Gravity

The flight mass and the connected center of gravity in flight must be determined prior to each flight. The following table and charts provide you with all necessary information to perform this part of your flight preparation.

**Warning:** You always have to expect that you burn all your fuel during one flight. Therefore, in all cases both conditions have to be verified to be within allowed limits: With tanks filled as on takeoff, and with tanks completely empty. In no case you may neither get out of the allowed cg range nor exceed MTOM as certified in your relevant country.

**Warning:** Explicit data used as example in the following charts have nothing to do with your real aircraft. The only purpose of these data is to illustrate the process of determining the required values for the flight planning. In any case you must make sure that you take the correct data as valid for your individual aircraft.

		<i>MC example</i>		<i>Your MC</i>	
		Mass [kg] [lb]	Mass Moment [kg*m] [in*lb]	Mass [kg] [lb]	Mass Moment [kg*m] [in*lb]
1.	Empty mass & mass moment (from most recent, valid Weight and Balance Report)	375.6 828.04	124.2 10 783		
2.	Combined pilot and passenger mass on front seats Lever arm: 0,42 m (16,5 in)	85 190	35.7 3 135		
3.	Mass loaded to luggage compartment behind the cabin Lever arm: 1,042 m (39.4 in)	12 25	12.5 985		
4.	<b>Total mass &amp; total mass moment with empty fuel tanks (total of 1. – 3.)</b>	<b>472.6 1043</b>	<b>172.4 14 903</b>		
5.	<b>Center of gravity with empty fuel tanks (Mass Moment of 4. divided by Mass of 4)</b>	<b>0,365 m 14.29 in</b>		<b>m in</b>	
6.	Usable fuel as verified to be filled on the aircraft * Lever arm: 0,26 m (10.23 in)	37 81.5	9,62 833.7		
7.	<b>Total mass &amp; total mass moment including fuel (4. plus 6.)</b>	<b>509.6 1 124</b>	<b>182.02 15 737</b>		
8.	<b>Center of gravity including fuel (Mass Moment of 8. divided by Mass of 8.)</b>	<b>0,357 m 14,0 in</b>		<b>m in</b>	
9.	The results in lines 4. and 7. must be all within the certified limits as defined for this aircraft in Chapter 6.1. Mass moments can be checked in the mass moment chart below. The results in lines 5. and 8. must be both within the limits as defined for this aircraft in Chapter 6.1				

\* One Liter of fuel weighs 0.725 kg – one US gal of fuel weighs 6.05 lb.

The table above provides you with the calculation scheme for the aircraft center of gravity for your flight. You have the possibility to calculate the moments analytically, or to read them from the following diagrams. Both methods will lead to the same result. Always make



## Aircraft Operating Instructions (AOI)

Type: *MC*

Series: *MC-LSA*

Page: 6-6

sure that you calculate the results for your takeoff configuration, and for the configuration with empty fuel tanks. In both cases the center of gravity must be within the defined limits.

The following chart “Loading Diagram” provides you with a graphical method to determine the mass moments of the individual positions. To obtain the value, select the correct weight (or volume) on the vertical axis. Go horizontally to the intersection with the correct loading graph. Go vertically down to the horizontal axis to obtain the mass moment value. Enter this mass moment value to the correct line in the analysis table above.

The next chart “Permissible Moment Range” allows you to verify if your aircraft is within the allowable moment range. The allowable range is shaded in this chart. Six center of gravity positions are marked as lines.

The third chart “Permissible CG Range” allows you to verify if your aircraft is within the allowable cg range. The allowable range is shaded in this chart. Forward and aft cg limit, as well as maximum permissible flight mass are marked as lines. This allows you to determine the actual center of gravity position you have achieved.

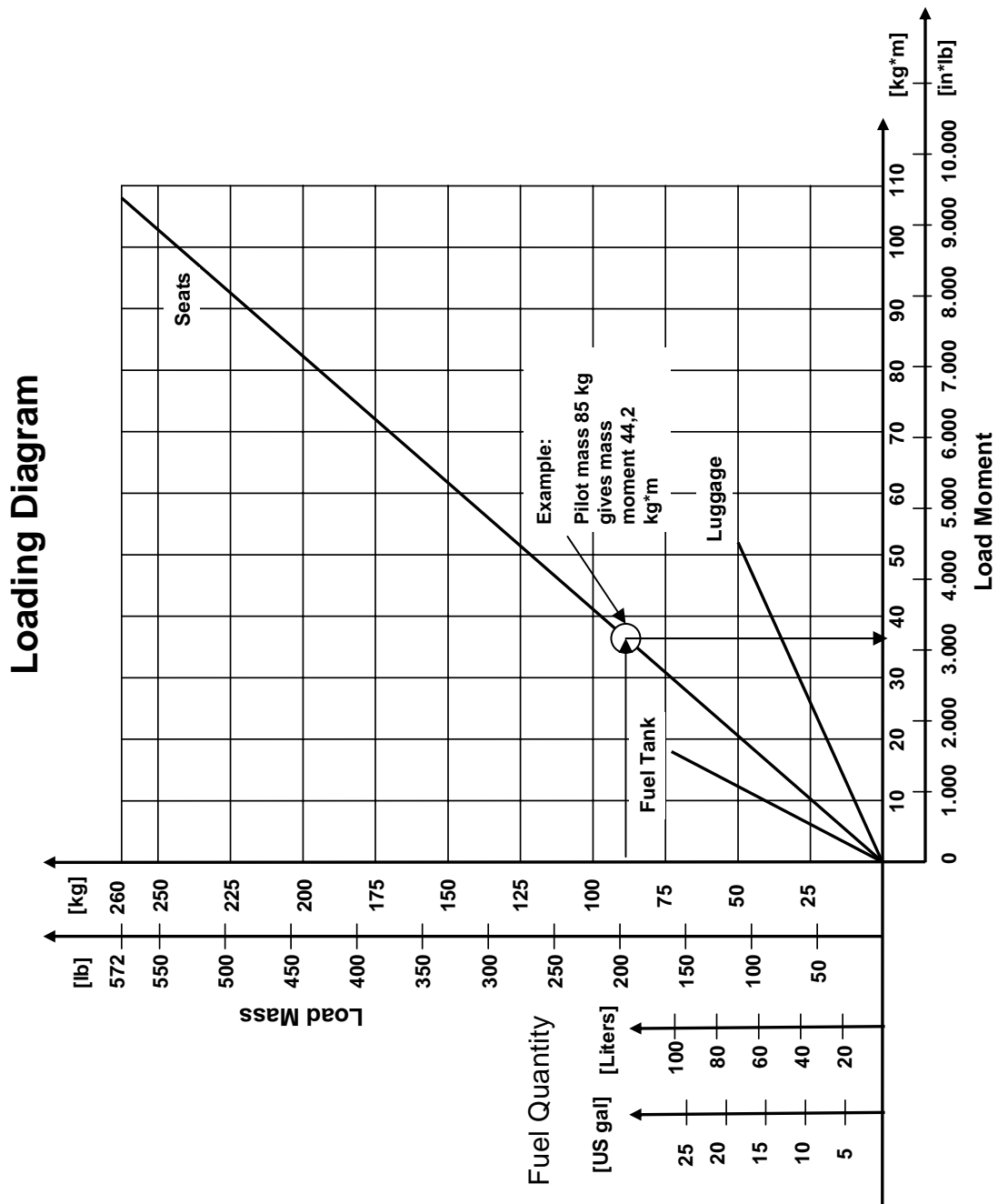

The example shown in this diagram represents the determination of the mass moment value as by the example shown in the analysis table. The pilot mass of 85 kg (190 lb) is selected at the vertical axis. Intersection with the line „Seats“ leads to a mass moment of 44,2 kg\*m (3895 in\*lb).

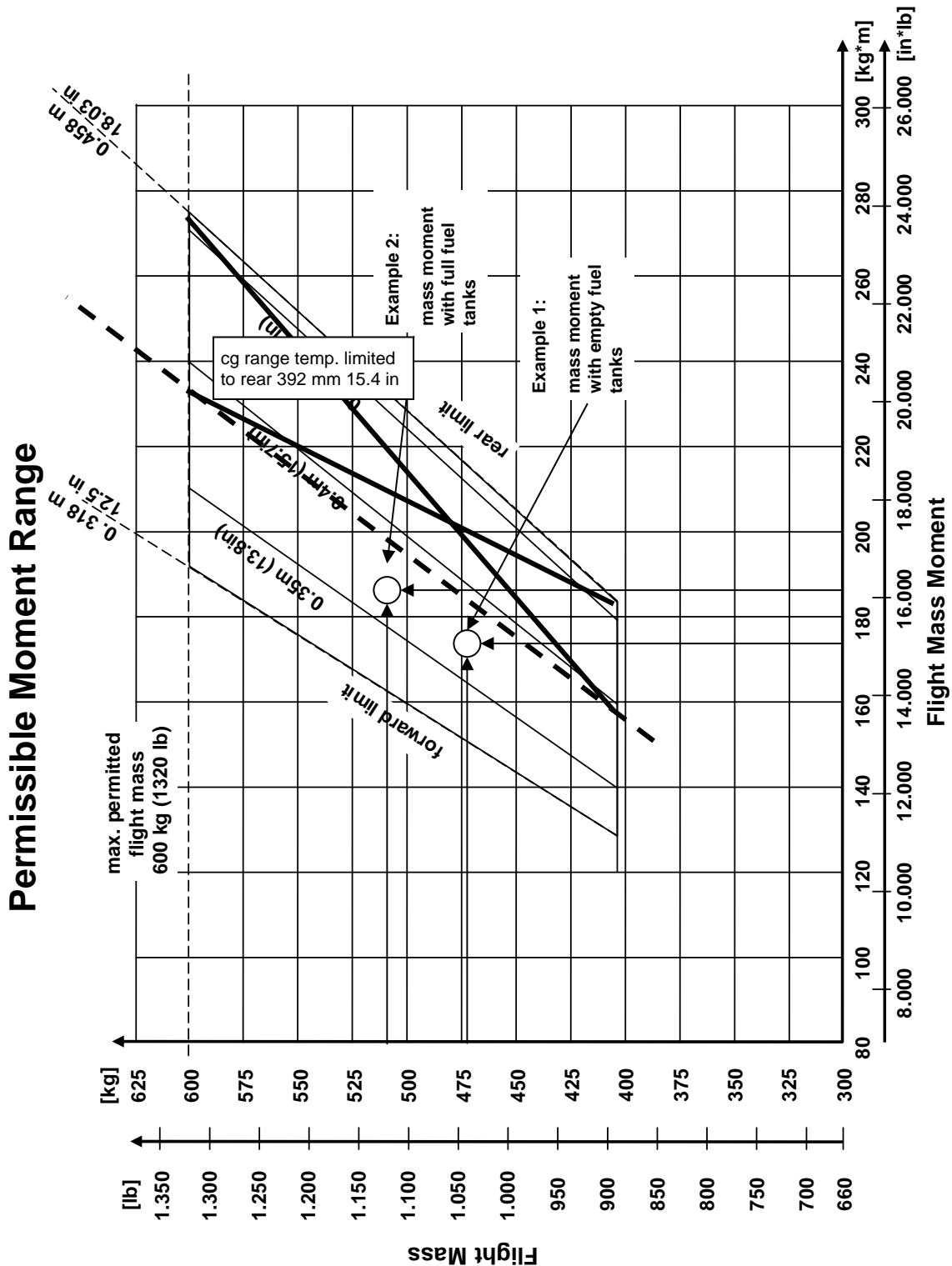

The example shown in this diagram represents the verification of the mass and mass moment values achieved as by the example shown in the analysis table. The aircraft with no fuel is represented by the values 472.6 kg (1041 lb) and 172.4 kg\*m (14 903 in\*lb). The aircraft takeoff fuel is represented by the values 509.6 kg (1.122 lb) and 182 kg\*m (15 737 in\*lb). Both values are within the allowed range. The two center of gravity positions can be determined as 0,356 m (14,0 in) and 0,365 m (14.37 in)

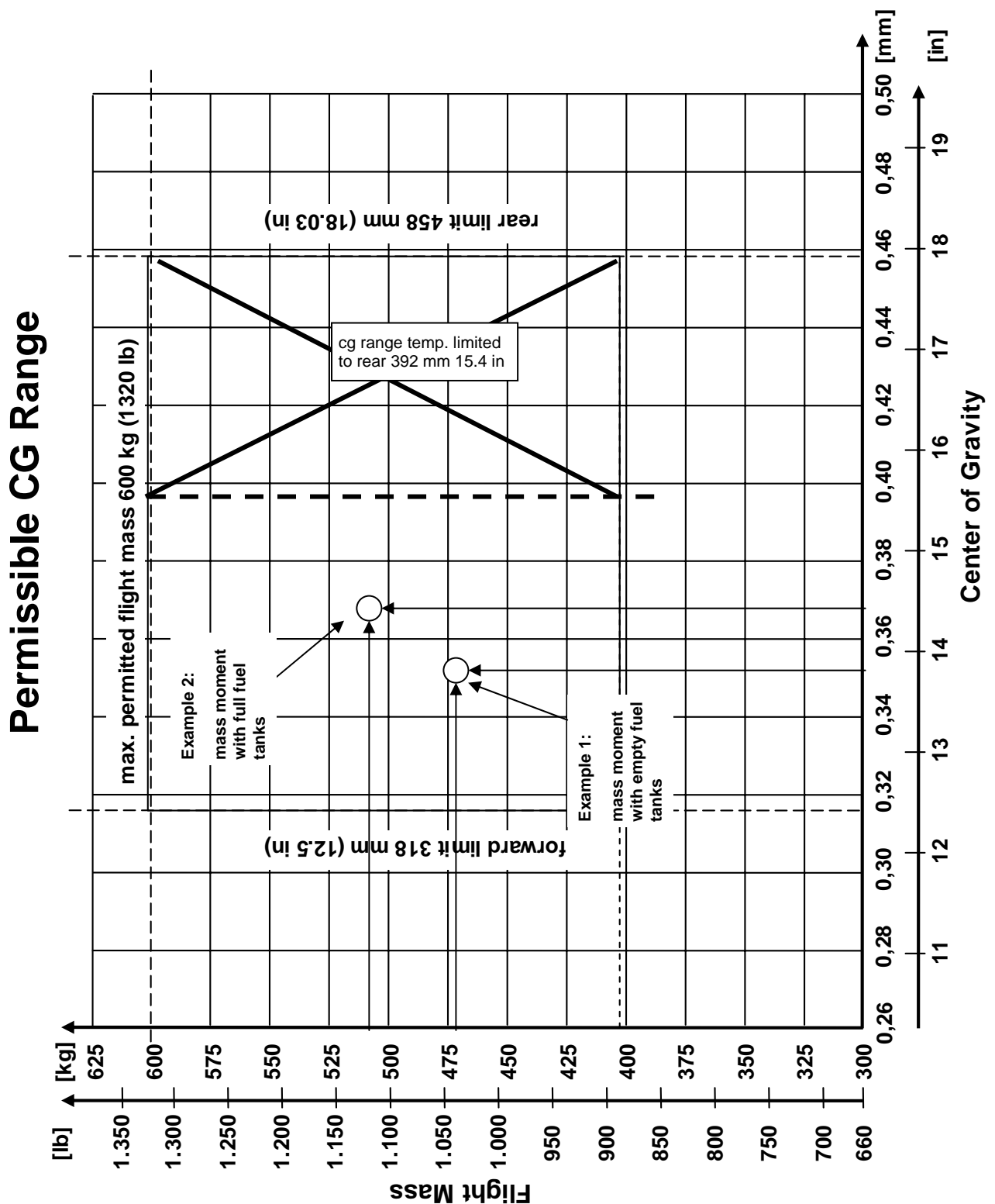

The example shown in this diagram represents the verification of the mass and cg position values achieved as by the example shown in the analysis table. The aircraft with no fuel is represented by the values 472.6 kg (1041 lb) and 172.4 kg\*m (14 903 in\*lb). The aircraft takeoff fuel is represented by the values 509.6 kg (1.122 lb) and 182 kg\*m (15 737 in\*lb). Both values are within the allowed range.



## Aircraft Operating Instructions (AOI)

Type: *MC*

Series: *MC-LSA*

Page: 6-10

### 6.4. Equipment

An example of an equipment list is given below. Each aircraft is delivered with an initial equipment list as part of this handbook. A new equipment list must be compiled and added to aircraft logbook and to this manual when there is any change to the equipment. The owner of the aircraft is responsible for ensuring that the equipment list is current.

The equipment list includes options which are not certified in all the countries in which the MC may be operated. It is the responsibility of the owner to ensure that national regulations are followed, for example with respect to the ballistic recovery system and the autopilot.

The equipment list is a summary of the aircraft at the time of an annual inspection or weighing. It is mandatory to record the installation and/or removal of instruments in the aircraft logbook.





# Aircraft Operating Instructions (AOI)

Type: *MC*

Series: *MC-LSA*

Page: 6-11

## Equipment List for LSA Aircraft



Type	MC	Prod. Number	A-09-01-31
Model	MC	Date	01.Mar.09

7

Item	Type	Manufacturer	Location	Weight	Installed
<b>1. Minimum Equipment</b>					
Airspeed indicator	7FMS423	Winter	-0.205 m	0.200 kg	X
Altimeter	5-410-20	U.M.A., INC	-0.210 m	0.220 kg	X
Compass	MCPN-2	Falcon Gauge	0.070 m	0.350 kg	X
Rescue System	BRS-6 1350 HS	BRS	1.175 m	14.900 kg	X
Battery	SBS 8	Hawker	1.075 m	0.810 kg	X
Propeller 3 blade fixed pitch	CR3-65-47-101,6"	Neuform	-1.260 m	6.170 kg	X
<b>2. Additional Equipment</b>					
EFIS	EFIS-D100	Dynon Avionics INC.	-0.217 m	2.650 kg	X
EMS	EMS-D120	Dynon Avionics INC.	-0.265 m	3.150 kg	X
Engine Hour Counter	85094	Hobbs	-0.180 m	0.090 kg	X
<b>3. Additional Equipment Avionic</b>					
Radio	SL 40	Garmin	-0.284 m	2.660 kg	X
Transponder	GTX327	Garmin	-0.210 m	1.415 kg	X
GPS	GPSMAP696	Garmin	-0.169 m	1.200 kg	X
ELT	AK-450	AMERI-King Co	1.085 m	2.000 kg	X
Intercom	PM 3000	PS Engineering	-0.175 m	0.850 kg	X
<b>4. Optional Equipment</b>					
Oil and Water Thermostat	-	Flight Design	-0.970 m	1.670 kg	X
Autopilot 2 / 3 Axis	CT Pilot 2/3- Axis	Trutrak			
Stroke / Position Light	EPL / ACL / ERB	Thiesen	2.616 m	0.640 kg	X
Landing Light LED	01-0771125-10 Rev.E	Whelen Engineering	-1.255 m	0.150 kg	X
Sport Seat Leather and cushion	-	Flight Design	0.860 m	2.900 kg	X
Fire Extinguisher			0.900 m	0.500 kg	X
Main Wheel Fairings	-	Flight Design	0.630 m	1.600 kg	X
Nose Wheel Fairing	-	Flight Design	-0.820 m	1.070 kg	X
<b>5. Misc. Equipment</b>					
Total Weight All Equipment			0.196 m	65.380 kg	

L'anzberg  
Signature

Kherson, Ukraine  
City

01.Mar.09  
Date

AA 04300001

Revision No. 00

Date: 10 July 2009



# Aircraft Operating Instructions (AOI)

Type: *MC*

Series: *MC*-LSA

Page: 6-12

## Equipment List for LSA Aircraft



<b>Type</b>	MC	<b>Prod. Number</b>	A-09-01-31
<b>Model</b>	MC	<b>Date</b>	01.Mar.09

Item	Type	Manufacturer	Location	Weight	Installed
<b>1. Minimum Equipment</b>					
Airspeed indicator	7FMS423	Winter	-8.1 in	0.44 lb	X
Altimeter	5-410-20	U.M.A., INC	-8.3 in	0.49 lb	X
Compass	MCPN-2	Falcon Gauge	2.8 in	0.77 lb	X
Rescue System	BRS-6 1350 HS	BRS	46.3 in	32.85 lb	X
Battery	SBS 8	Hawker	42.3 in	1.79 lb	X
Propeller 3 blade fixed pitch	CR3-65-47-101,6"	Neuform	-49.6 in	13.60 lb	X
<b>2. Additional Equipment</b>					
EFIS	EFIS-D100	Dynon Avionics INC.	-8.5 in	5.84 lb	X
EMS	EMS-D120	Dynon Avionics INC.	-10.4 in	6.94 lb	X
Engine Hour Counter	85094	Hobbs	-7.1 in	0.20 lb	X
<b>3. Additional Equipment Avionic</b>					
Radio	SL 40	Garmin	-11.2 in	5.86 lb	X
Transponder	GTX327	Garmin	-8.3 in	3.12 lb	X
GPS	GPSMAP696	Garmin	-6.7 in	2.64 lb	X
ELT	AK-450	AMERI-King Co	42.7 in	4.41 lb	X
Intercom	PM 3000	PS Engineering	-6.9 in	1.87 lb	X
<b>4. Optional Equipment</b>					
Oil and Water Thermostat	-	Flight Design	-38.2 in	3.68 lb	X
Autopilot 2 / 3 Axis	CT Pilot 2/3- Axis	Trutrak			
Strobe / Position Light	EPL / ACL / ERB	Thiesen	103.0 in	1.41 lb	X
Landing Light LED	01-0771125-10 Rev.E	Whelen Engineering	-49.4 in	0.33 lb	X
Sport Seat Leather and cushion	-	Flight Design	33.9 in	6.39 lb	X
Fire Extinguisher			35.4 in	1.10 lb	X
Main Wheel Fairings	-	Flight Design	24.8 in	3.53 lb	X
Nose Wheel Fairing	-	Flight Design	-32.3 in	2.36 lb	X
<b>5. Misc. Equipment</b>					
Total Weight All Equipment			7.7 in	144.14 lb	

L'anzberg  
*Signature*

Kherson, Ukraine  
*City*

01.Mar.09  
*Date*



## Aircraft Operating Instructions (AOI)

Type: *MC*

Series: *MC*-LSA

Page: 7-1

## 7. DESCRIPTION OF AIRPLANE AND SYSTEMS

### 7.1. Airframe

The Flight Design MC is a two seat LSA aircraft with high strutted wing of conventional arrangement with a cruciform tail. The primary structures are made of metal with aluminum skin. The aircraft is equipped with a tricycle landing gear with a steerable nose-wheel.

The spacious cockpit is comfortably accessible to the pilot and passenger via two large doors held open by gas struts. The extensive acrylic windshield offers, for a high-wing aircraft, outstanding visibility. Additional skylight windows above the pilots head complete the basis for excellent visibility. The rear side windows allow rearward vision and give the cabin an open feeling.

Behind the cockpit a spacious baggage compartment mounted, directly behind the occupant seats. The baggage compartment is equipped with standard tie-downs for simple baggage fixation. The baggage compartments are accessed through the cabin, folding one or both seats forward.

#### 7.1.1. Assembly instructions

Assembly and disassembly of an LSA aircraft is only allowed to licensed mechanics. Instructions for assembly and disassembly are given in the separate MC LSA maintenance manual.

#### 7.1.2. Materials used for the airframe

The structural parts of the airframe are made of metal materials with best durability characteristics.

The wings of the aircraft are built in riveted Aluminum and fully covered. High loaded brackets are made of steel. The wing struts are made from Aluminum extrusion profiles with steel brackets.

The structure of the cabin area, up to the first frame of fuselage beam behind the doors is designed as a welded steel framework. The steel framework is fully covered with light weight composite panels, which allow a smooth and aerodynamically efficient outer shape. Due to the weight limitations of the LSA aircraft category these panels are made from high performance carbon, partially in sandwich design.

The tail beam of the fuselage, starting from the first frame, behind the cabin doors, is designed as riveted Aluminum skin-stringer construction.

Horizontal and vertical tails are also designed as riveted Aluminum construction.

Repair work on metal parts of airframe may be undertaken only by a qualified facility. For this reason, only general information about the materials used is given in this handbook. Should the aircraft structure be damaged, detailed information should be requested from the manufacturer.

Steel:	typically St 37
Aluminium:	typically 2024-T3
Rivets:	AN 470 AD; AN 470 A; Cherry "N"-rivets; Cherry "Q"-rivets



## Aircraft Operating Instructions (AOI)

Type: *MC*

Series: *MC-LSA*

Page: 7-2

Carbon, glass fiber:	various qualities Lange & Ritter, Gerlingen
Resin and hardener:	Larit L 285 Lange & Ritter, Gerlingen
Core material:	Rohacell, Airex various qualities Lange & Ritter, Gerlingen
Screws and bolts:	unless otherwise stated, class 8.8 and 10.9 zinc-plated or stainless steel, according to DIN standard

**Warning:** Generally, should the aircraft structure be damaged, detailed information must be requested from the manufacturer. This also applies to standard parts such as bolts, rivets and bearings.

### 7.1.3. Baggage compartments

The aircraft has two possibilities to stow baggage or personal items:

- 1) baggage compartment behind the pilot's seats
- 2) a hat or jacket rack at the main frame, behind the seats

**Warning:** Baggage always must be carefully stored. Even in apparently calm weather, turbulence can occur at any time. Baggage poses a great danger as it can slip in such a way as to adversely affect or even block the controls. Loose objects flying around in the cockpit can injure the pilot and/or passengers. Displaced baggage can also adversely affect the center of gravity of the aircraft, making it no longer controllable.

The baggage compartment is accessible through the cabin when inclining the seats forward. A maximum of 50 kg (110 lbs) of luggage are allowed when evenly distributed. The compartment is equipped with luggage tie down points. Straps (not delivered with the aircraft) shall be used on these tie downs to properly fix luggage.

The hat rack offers storage space for small and flat objects only. The size of the object may not exceed 25 cm x 25 cm x 8.5 cm (10 in x 10 in x 4 in) nor weigh more than 2.5 kg (5 lbs). This storage space may only be used if the baggage net is in place. The net can be removed at the forward edge to facilitate loading. It must be hung back on all three hooks when loading has been completed.

**Warning:** The pilot is responsible for ensuring that any baggage has been properly stored and secured before taxi and take-off.

## 7.2. Systems

### 7.2.1. Engine

The engine of the MC is a standard Rotax 912 series engine. It is a horizontally opposed, four-cylinder, four stroke engine with central camshaft-push rod-OHV, liquid-cooled cylinder heads and a dry sump, pump-fed lubrication system. The propeller is attached to the engine by an integrated gearbox (2.43:1 or 2.27:1 reduction) with a mechanical vibration damper. It is equipped with two constant depression carburetors. The engine has an electric starter and a capacitive discharge (CDI)-dual ignition. As an option the engine can be equipped with a slipper clutch.

Fresh air is provided to the engine through a NACA air inlet on the right side of the lower cowling. The air passes through a cylinder air filter and is guided to the airbox. From there the two carburetors are supplied with air. The airbox allows selection of preheated air. The preheated air is provided through a separate air intake below the water cooler. The air is preheated in a shroud around the exhaust muffler.

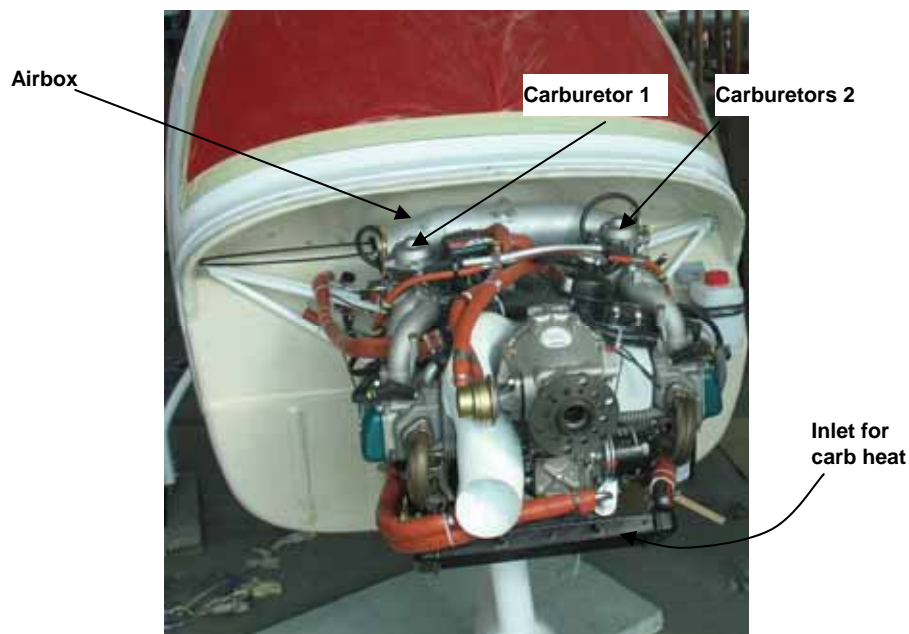

**Warning:** Since the supply ducts for fresh air and heated air are separate up to the air box, the engine can be easily supplied with alternate heated air should the air inlet become blocked in flight.





## Aircraft Operating Instructions (AOI)

Type: *MC*

Series: *MC*-LSA

Page: 7-4

### 7.2.2. Propeller

The MC may be equipped with various propellers. The operating handbook and the maintenance manual of the relevant propeller published by the propeller manufacturer are delivered with the aircraft and must be studied in detail. The following propellers are approved for usage on the MC:

Manufacturer	Parameters
Neuform	TXR 2-65-47-101.6, 1.66 m diameter, 2 blade, composite propeller, ground adjustable
Neuform	CR3-65-47-101.6, 1.70 m diameter, 3 blade, composite propeller, ground adjustable
Kaspar- Brändel	KA1, 1.60 m diameter, 3 blade, composite propeller, ground adjustable
PowerFin	A R 65 T, 1.65 m diameter, 3 blade, composite propeller, ground adjustable

The ground adjustable propellers are factory-set to prevent over-revving the engine during take-off, climb and level flight. Full throttle static engine speed on the ground will be roughly 4900 RPM. Engine speed of approximately 4800 - 4900 RPM is achieved during climb, whereas almost 5500 RPM are reached during level flight with full throttle, corresponding to maximum continuous engine speed. This pre-setting makes the monitoring of the correct propeller speed in flight very simple for the pilot.

Variable-pitch propellers are controlled via a hydraulic adjustment mechanism. The lever has several indexed positions. To set the propeller, the notch under the lever is released, the lever moved to the desired position and the notch locked in place. Via a hydraulic cylinder in the lever and the corresponding line, a hydraulic actuator in the engine compartment is activated. The actuator is located on the rear side of the gearbox, above the crankshaft. The propeller is adjusted via a control rod which runs through the hollow propeller shaft.

The variable-pitch propellers are factory-set so that engine speed at lowest pitch during take-off and initial climb does not exceed the maximum short-term permissible speed of 5800 RPM. The climb speeds given in the normal procedures section must be observed exactly. Should they be exceeded, there is a risk of the engine over-revving and being damaged.

**Warning:** If a variable-pitch propeller is not operated properly, the engine may over-rev. Propeller speed will increase constantly with increasing airspeed. For this reason, the variable-pitch propeller must already be adjusted to a higher pitch during climb. It is the responsibility of the pilot to ensure that engine operating limits are adhered to.



### 7.2.3. Fuel system

A fuel tank with a capacity of 50 l (13.2 gal) is installed to the leading edge section of each wing. Fuel tanks are integral tanks. The fuel tanks are each equipped with anti-sloshing ribs. The innermost anti-sloshing rib is equipped with a flapper valve at the lower opening. The flapper does not completely seal the opening. However, it greatly restricts the return flow of fuel into the outer chamber when one wing is low (sideslip). A sideslip can thus be undertaken even when low on fuel without risking fuel starvation to the engine.

Fuel is filled into the outermost section via a fuel filler opening on the upper side of each wing's consoles. To open the fuel filler cap, the lever in the cap must be raised and turned 90° anti-clockwise. The cap can then be removed. The cap is properly shut when the lever is pressed down into position.

**Warning:** The pilot must be certain during the preflight inspection that the fuel filler caps are properly shut. An improperly closed or even missing fuel cap leads to a massive loss of fuel in flight as the fuel is sucked out of the tank.

The tanks are vented individually by poles mounted to the fuel filler caps. These tubes are equipped with a cap that prevents rain water to enter the fuel tanks. The lower edge of this cap is cut under an angle, so that the dynamic air pressure in flight slightly overpressures the fuel tank in flight.

**Warning:** Care must be given to the correct position of the fuel filler cap and thus the vent tubes. The lower edge of the vent tube cap must be such that it goes up towards flight direction.

Each tank outlet has a coarse screen which can be removed from the tank for visual inspection and cleaning. Cleaning intervals are defined in the MC LSA maintenance manual.

Fuel is fed by gravity via two fuel lines along the A columns. They have a large volume so that even with virtually empty tanks, enough fuel is available in a sideslip to ensure engine power for landing. The two lines are connected to each other via a T-fitting. The fuel shutoff valve is located behind a second fuel filter and directly in front of the line through the fire wall. The fuel flow sensor mounted on the fuel line in cockpit, near firewall.

The fuel flows from here into the gascolator which finally is equipped with a very fine filter screen. The gascolator is the lowest point in the fuel system and has a drain valve. The fuel system must be drained at this point before the first flight day and after filling up with fuel.

The fuel pump picks up fuel from the gascolator and feeds the fuel to the two carburetors. Excess fuel is pumped back to the gascolator.

The fuel system is presented schematically in the following diagram.

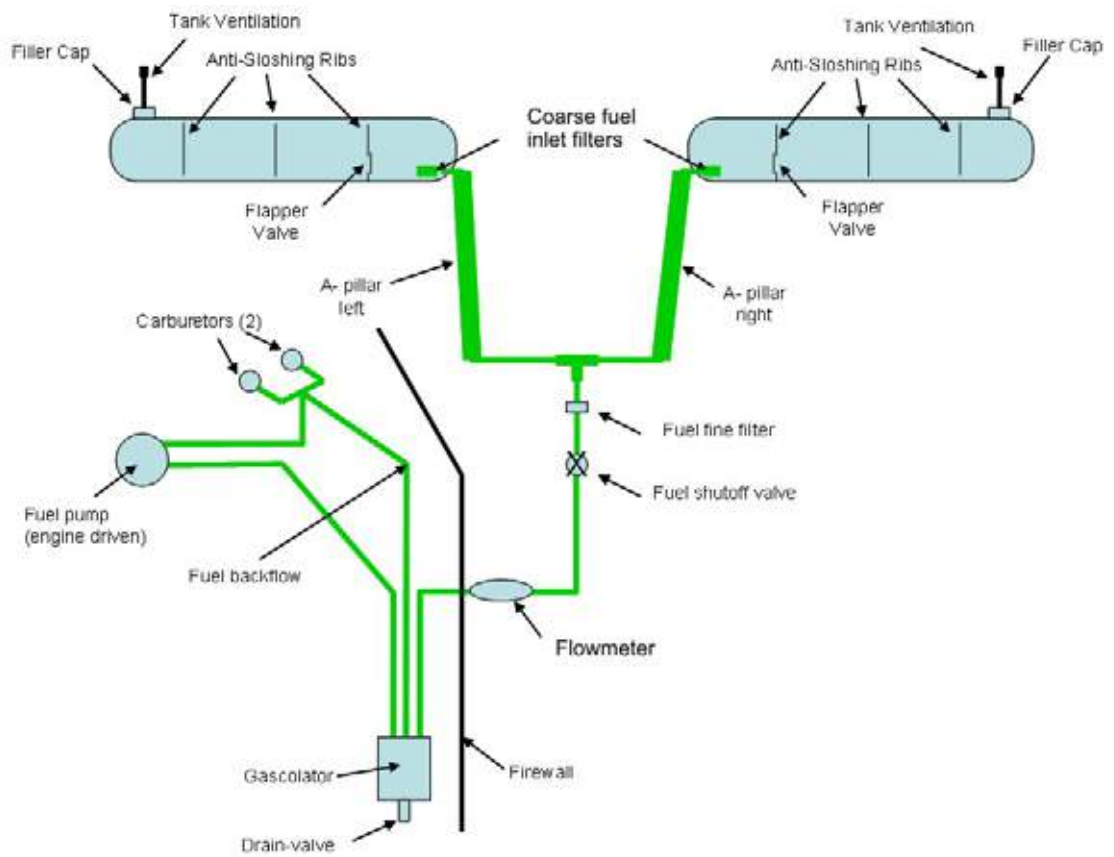





## Aircraft Operating Instructions (AOI)

Type: *MC*

Series: *MC*-LSA

Page: 7-7

### 7.2.4. Electrical system

The design of the electrical system is based on the ASTM F2245 (design specifications for LSA) requirements for night flight. Only high-quality wiring is used, the cross-sections and insulation meet applicable aviation requirements.

The electrical system is based on a 12V, 7Ah lead-gel battery which is charged with a maximum output of 250 Watt by a DC integrated alternator. This battery has very high performance and needs specific charging procedure if discharged. If properly maintained it has a very long service life.

Power is distributed via a common power bus, which the fuses and circuit breakers of the individual instrument groups are directly connected. Power is then transferred to the instruments and avionics using switches where it is necessary. All ground lines are connected to the battery via a ground bus. The avionics are grounded separately from the rest of the aircraft in order to avoid interference.

The layout of the electrical system is depicted in the block diagrams in Appendix 4. They show the wiring layout and help to explain the function of the installation with respect to power supply as well as the data interchange between the individual instruments. Should more detailed schematic diagrams be required for maintenance purposes, these can be requested from Flight Design.



### 7.2.5. Landing gear and brakes

The main landing gear of the MC is made from composite materials and is of the cantilever spring type. The cantilever spring ensures harmonic deflection behavior with good damping.

The two separate struts (left / right) are mounted with brackets to the steel fuselage framework. The struts are attached to the structure by two bolts at the top ends. A clamp cushioned by a thin layer of rubber at the fuselage pass through supports the strut. The fuselage pass through is faired to an aerodynamically optimized form.

At the bottom of the landing gear strut there is a stub axle to which the main wheels and the brakes are attached. The main wheels have removable fairings.

The main wheels of the MC have hydraulic disc brakes which are activated via a centrally located lever in the cockpit. The brake lines are reinforced with fiber cloth and connections are crimped tightly on to the lines, thus ensuring high line rigidity and stability at a low installed weight. This also results in better brake efficiency.

By blocking the return line, the brakes can be locked for a parking brake function. The locking lever is in the middle console in the cockpit, directly behind the throttle quadrant. The parking brake can be locked before activating the brakes. The brakes can then be activated once through the check valve. The check valves keep the system under pressure, thus making single-hand operation of the parking brake simple.

**Warning:** Changes in temperature or longer parking times can cause a hydraulic brake system blocked in this way to lose pressure resulting in released brakes. Therefore, when the aircraft is parked usage of chocks is highly recommended.

The nose gear leg is mounted to the fuselage steel framework in front of the firewall, below the big engine mount. The nose gear is steerable. The rotating section is actuated from the pedals using pushrods.

The nose gear has an aerodynamically optimized composite fairing. This fairing can only be removed completely after the nose gear fork has been removed. Changing of the tire is possible without removing of the nose gear fairing. It is sufficient to lift the fairing slightly. When remounting the fairing, ensure that it is positioned properly into the guide track at the top end of the fork. The fairing could, otherwise, flutter and become damaged.



## Aircraft Operating Instructions (AOI)

Type: *MC*

Series: *MC*-LSA

Page: 7-9

### 7.3. Flight controls

#### 7.3.1. Dual controls

The aircraft has dual controls, thus allowing operation from both seats. The dual controls cannot be separated.

Even although the aircraft can be flown from both seats, the pilot in command sits in the left seat. The arrangement of the instruments and operating devices is primarily optimized for this seat. Thanks to the dual controls, the aircraft is well equipped for training and instruction.

#### 7.3.2. Rudder and nose wheel steering

The rudder is activated via control cables which pass through the tunnel (cabin) and are guided inside the lower tail boom structure.

The left and right foot pedals are installed to torsion tubes that pass through the tunnel. The turnbuckle units to tension the cables and the connection to the nose wheel steering are in the tail fuselage, right in front of the stabilizer. They are accessible through a hatch at the left tail fuselage side..

**Warning:** We advise against making adjustments to the rudder steering. Due to the mechanical interlinking, this can adversely affect cable tension and/or wheel alignment. Please contact a Flight Design service station.

#### 7.3.3. Elevator and Elevator Trim

The complete horizontal tail is designed as rib spar construction with full aluminium skin. The horizontal tail is attached to the upper side of the tail beam and can be removed for road transport of the aircraft.

The elevator is attached to the stabilizer using a piano hinge. The elevator is actuated from the control sticks with pushrods installed along the lower side of the cabin framework section and the aluminum tail beam.

The elevator is trimmed with a trim tab, integrated to the trailing edge of the elevator, and extending from the middle of the elevator to both sides. The trim tab is actuated by an electric servo that is installed in elevator before trim tab. See illustration below. The trim servo is actuated by a control switch mounted on the left side of throttle quadrant. When the switch is pushed the servo moves, as long as the button is pressed in the desired direction. Elevator trim indication is provided on the screen of the Dynon D120 or D180 EMS.

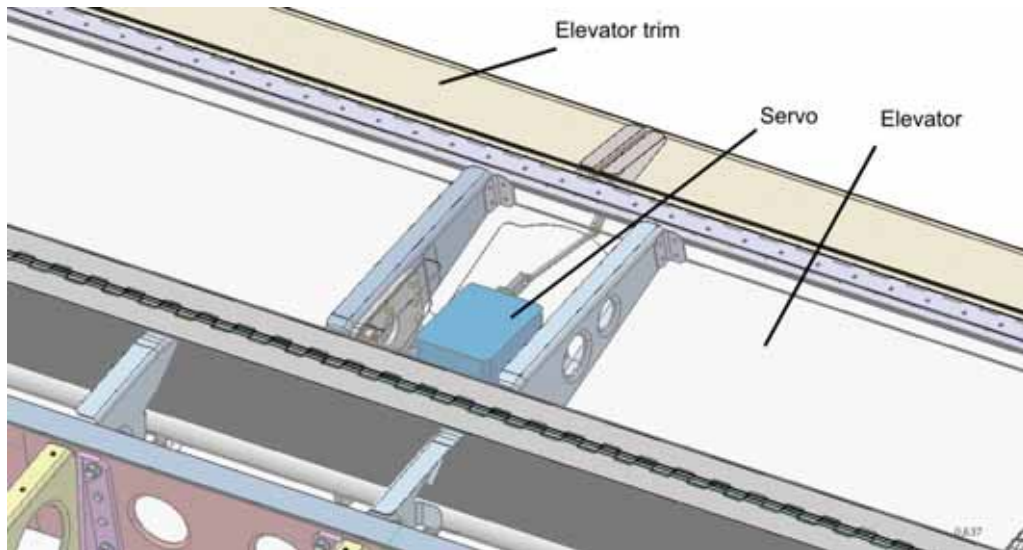

### 7.3.4. Ailerons

The ailerons are actuated by pushrods which run from the control stick through the tunnel and follow the B-pillars up to the wing root ribs. From here again pushrods follow the main spar inside the wing. The ailerons are actuated at their inboard end rib.

The ailerons are not coupled with the flaps. When extending the flaps the ailerons stay. This results in an aerodynamic twist of the wing, resulting in higher drag as desired for a descent and approach.

### 7.3.5. Wing flaps

The flaps are driven by a geared electric motor and are activated via the flap control in the lower section of the instrument panel. The desired flap setting is selected with a lever switch. The position indicator will flash as long as the flaps are moving to the desired setting. Once the desired setting has been reached, the position will be constantly illuminated. The flaps may be set at any of the following positions:

-12° (fast cruise), +0° (retracted), +15°, +30°, +35°.

The flap motor is positioned under the tunnel and actuates a torsion tube located right above the main landing gear attachments. From here the flaps are activated by pushrods and rockers. The main torsion tube ensures that the flaps are always extended symmetrically.

**Warning:** An individual maximum airspeed is defined for each wing flap setting. The pilot must observe these limits to ensure that the aircraft and the flight controls are not over-stressed.

The flap servo has an internal load-limiting device which prevents the extension of the flaps at too high airspeeds which could cause sustainable damage to the structure. Should the indicator blink constantly when extending the flaps, airspeed should be reduced. If the flaps then extend, the internal load-limiting device was in operation. If extension speed is below the maximum speed for flap extension as given in the instruction, the flap system may be out of adjustment. The nearest Flight Design service station should be contacted.

The flap control dual circuit breaker is to be found directly adjacent to the flap controls. It will pop if the flap servo is continuously over-loaded. As it is a thermal circuit breaker, it



## Aircraft Operating Instructions (AOI)

Type: *MC*

Series: *MC-LSA*

Page: 7-11

can take some time before it can be pushed back in. We emphasize once again that the MC can be flown and landed safely in any flap position. Refer to Chapter 3 - Emergency Procedures.

### 7.3.6. Ballistic recovery system

The MC LSA is always delivered with a ballistic recovery system from BRS. Deployment of the recovery system is described in detail in Chapter 3 - Emergency Procedures.

**Warning:** The recovery system is a very important safety element of this aircraft. Even assuming that the recovery system will never be used, it is absolutely essential that the pilot regularly familiarizes him/herself with the deployment of the system and the simple actions involved. It also pays off to watch the videos showing successful deployment of the parachute which the recovery system manufacturer has posted on its website. Some of the videos show real-life deployment filmed from the cockpit and illustrate well just how useful this system can be in doubtful situations.

The ballistic recovery system comprises a recovery parachute and a ballistic rocket which are located above the baggage compartment behind the hat rack fairing. The rocket is activated via a pull cable attached to the deployment handle on the upper side of the tunnel in the cockpit, right between the seats.



The parachute egress hatch is on the upper side of the fuselage, directly above the recovery system. The opening is covered by a light flap which easily lifts off when the system is deployed.

After deployment of the recovery system, the aircraft is suspended by four main belts. Two front and two rear belts are connected to the steel fuselage framework, directly next to the wing attachment points.

In non-deployed condition the belts are covered by the fuselage roof and stored behind the main bulkhead. When deployed, typically the opening forces are strong enough to pull these belts through the roof. In very rare cases (extreme low aircraft weight and at stall speed) it might happen that the belts do not tear open the aircraft roof. In this case the aircraft will descend with little more pitch down, and the rear belt will be not tightened.



## Aircraft Operating Instructions (AOI)

Type: *MC*

Series: *MC*-LSA

Page: 7-12

The following picture shows the installation of the recovery system in the aircraft. The next illustration (not to scale!) shows the aircraft position suspended under the parachute.

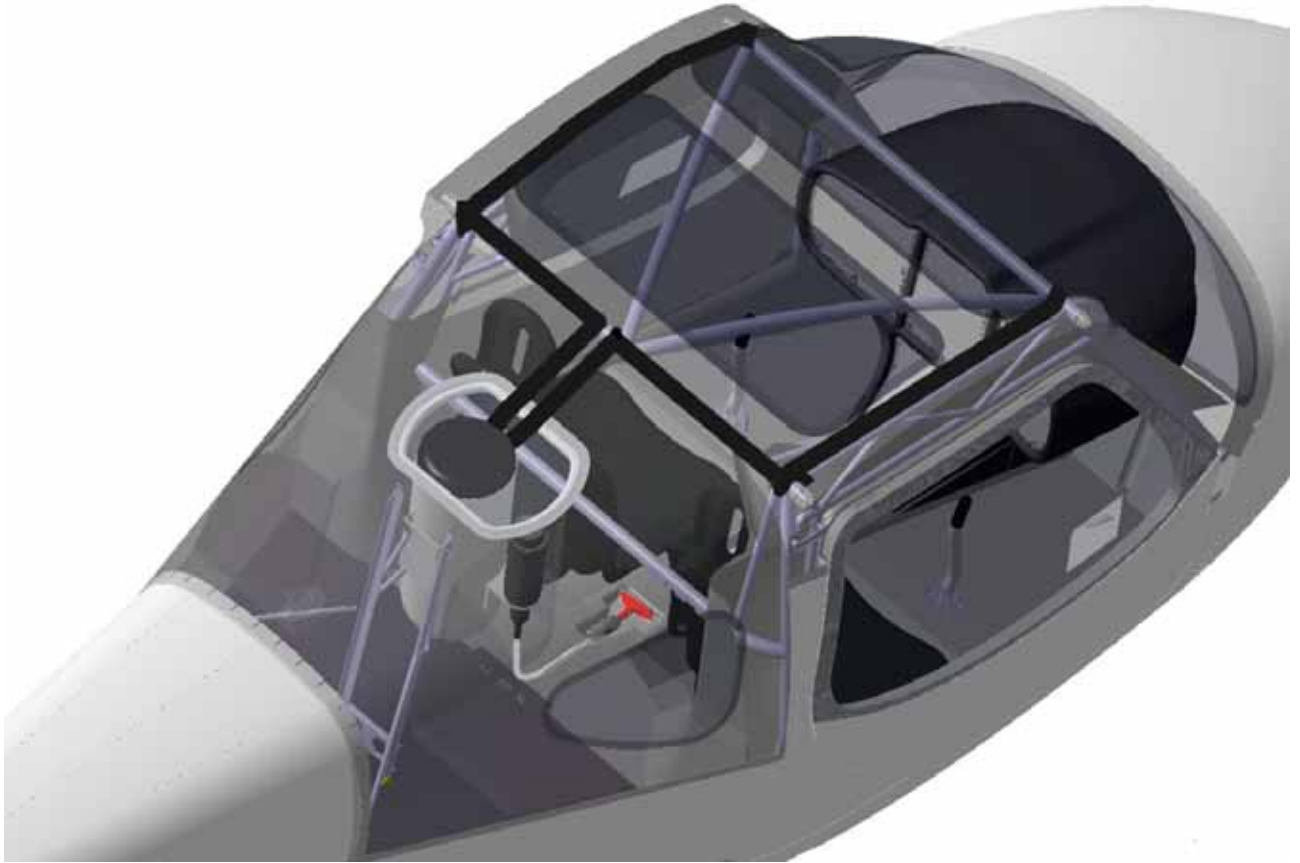





# Aircraft Operating Instructions (AOI)

Type: *MC*

Series: *MC*-LSA

Page: 7-13





## Aircraft Operating Instructions (AOI)

Type: **MC**

Series: **MC-LSA**

Page: 7-14

### 7.4. Cockpit

#### 7.4.1. Instrument panel

The instrument panel for the MC is available in various layouts. The large mushroom-shaped panel is usually standard. It has four sections - upper left, upper center, upper right and lower. The flight instruments are located in the three upper panels whereas the lower panel contains aircraft controls, the switches panel and the intercom.

Standardized numbering of equipment based on the table below is used for the diagrams on the following pages.

1	EMS, Dynon 120 electronic flight information system
2	EFIS, Dynon 100 engine monitoring system
3	Autopilot FD Pilot 1 axis / 2 axis / 2 axis w/ vertical speed control
4	Back up airspeed indicator D 57 mm (2-1/4")
5	not used
6	Back up altimeter D 57 mm (2-1/4")
7	not used
8	not used
9	Slip indicator
10	not used
11	Hobbs hour meter
12	Alarm light, alternator
13	Alarm light, electronic engine monitoring
14	Comm radio, Garmin SL40
15	Nav/Comm, Garmin SL30
16	Transponder, GTX 328 (Mode A/C) oder GTX 330 (Mode S)
17	GPS, Garmin 496
18	Dynon HS34 input system for GPS & VOR for the EFIS
	Dynon FlightDEK 180 EMS and EFIS monitoring system



## 7.4.2. Upper panel

Panel with Glass cockpit, without NAV radio:

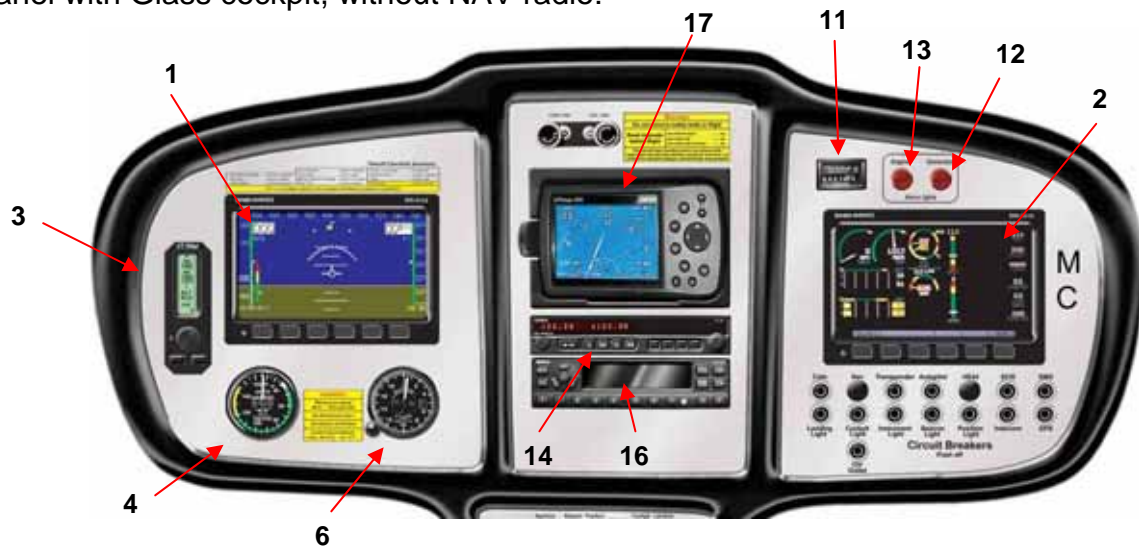

Panel with Glass Cockpit, with NAV radio:

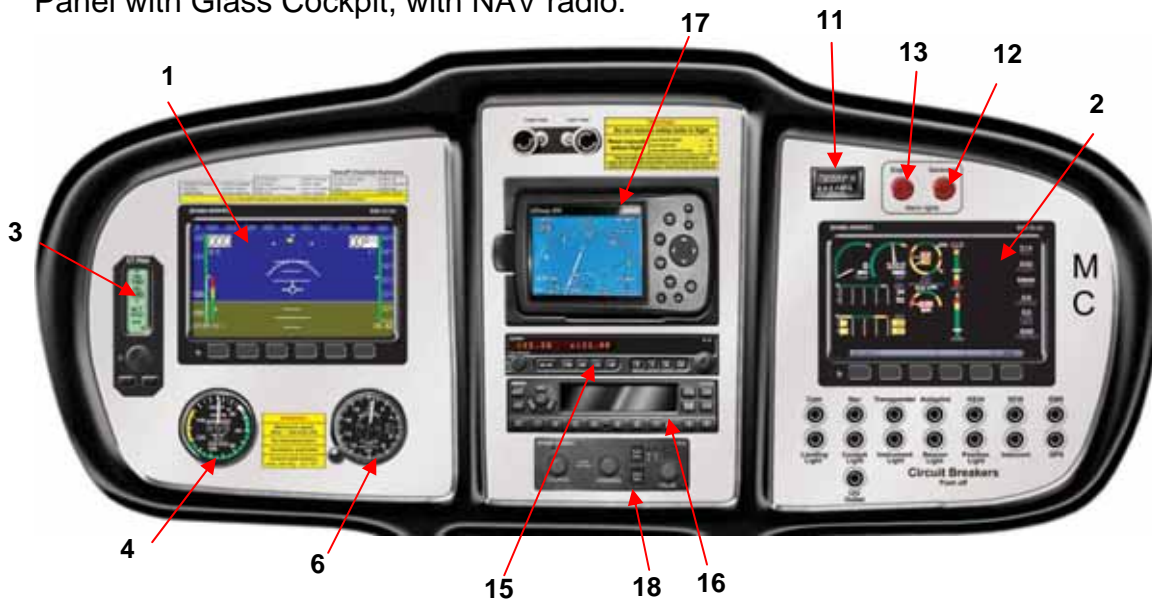

### 7.4.3. Circuit Breakers

All circuit breakers – except the circuit breaker for the flap controller, which is located directly next to the flap controller – are located in the lower part of the upper right panel. Depending from the actual aircraft equipment these are installed. The following illustration shows the order of the circuit breakers.

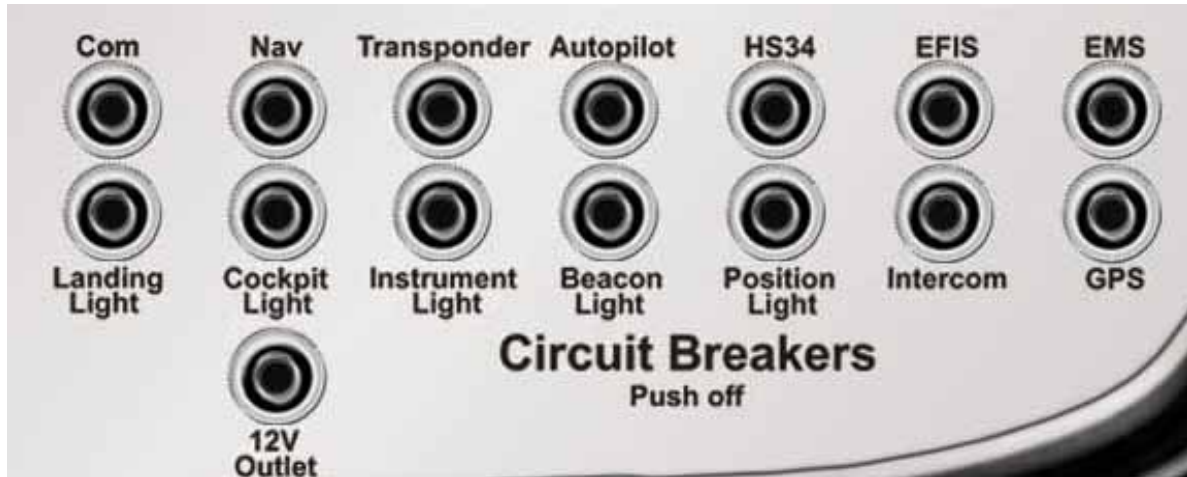

#### 7.4.4. Lower panel

The equipment in the lower panel varies only slightly. If no avionics are installed, there is no intercom. Otherwise, the controls and switches are always configured as shown below. The backup headphone jacks connect directly to the radio and can be used in case of a intercom failure.

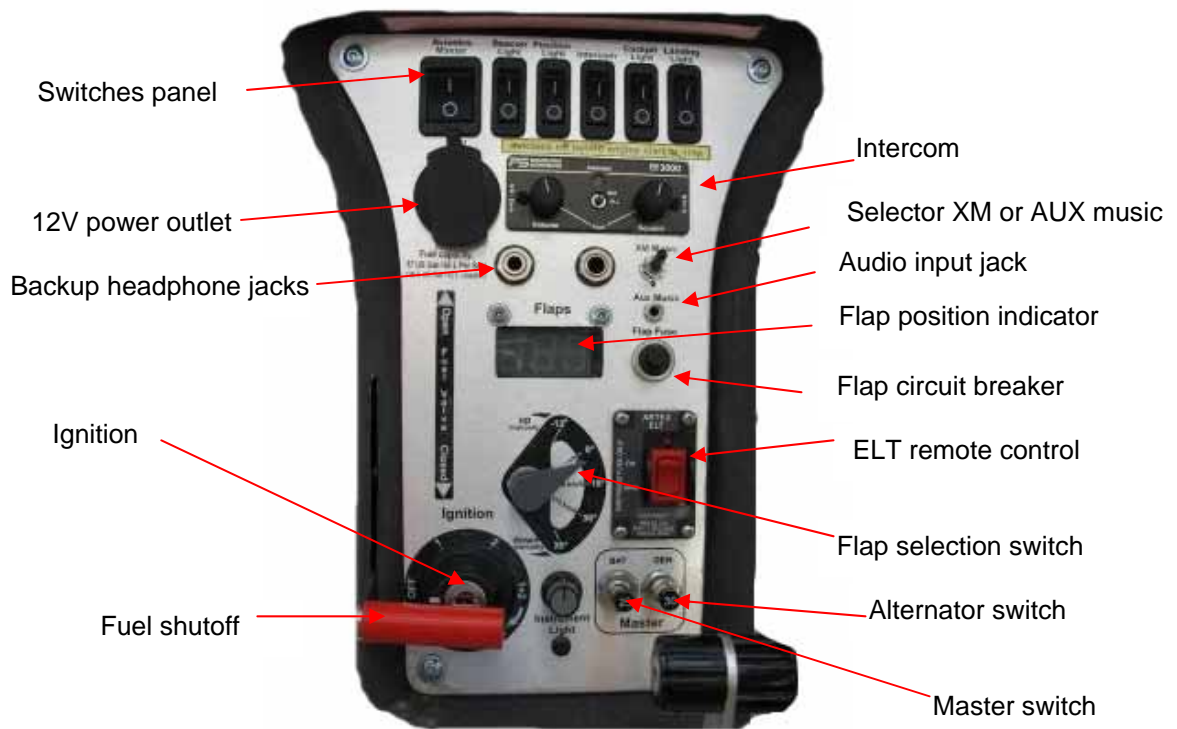

#### 7.4.5. Throttle quadrant

The throttle quadrant is located in the middle console/tunnel, in front of the lower instrument panel. It can be easily operated from both seats, although it is primarily designed to be operated from the left seat, by the pilot-in-command.

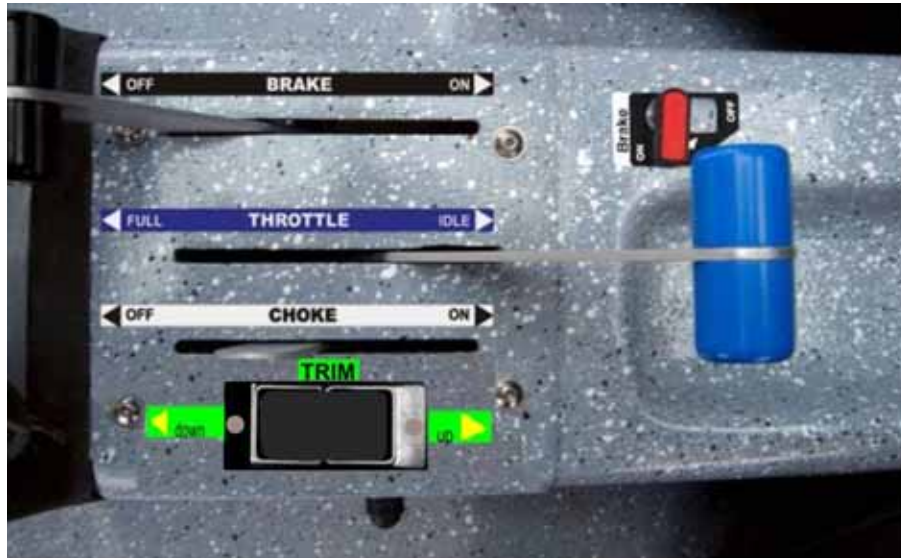

#### 7.4.6. Carbon monoxide detector

Every MC aircraft is equipped with Carbon Monoxide (CO) Detector.

The owner (pilot) is responsible to watch the date on the detector and when necessary – replace it. The owner (pilot) is also responsible to mark the date when install the new one. The manufacturer of the detector clearly specifies the product lifetime that has to be considered.

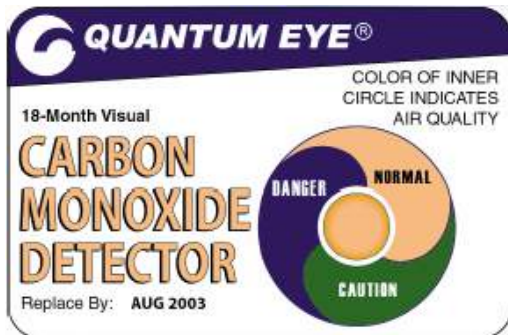

The picture shows the detector installed upon delivery of the plane. There are multiple detectors available on the market. You can use any one that is specified for aircraft usage. Befor usage check suitability for the type of operation of the MC aircraft.



# Aircraft Operating Instructions (AOI)

Type: **MC**





Series: **MC-LSA**

Page: 7-20

## 7.5. Placards and markings

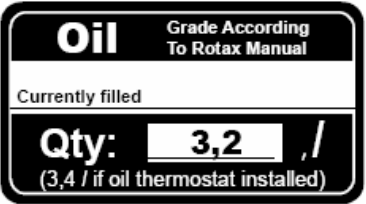
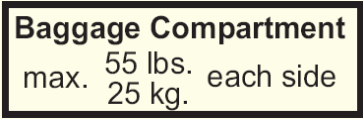
	Item	Location												
	White arc	35 – 70 kts (65 – 130 km/h) airspeed indicator												
	Green arc	50 – 120 kts (92 – 222 km/h) airspeed indicator												
	Yellow arc BRS 1350	120 – 135 kts (222 – 250 km/h) airspeed indicator												
	Red line	135 kts (250 km/h) airspeed indicator												
	Red line tach	5800 rpm rpm indicator												
	Red line	102 psi (5 bar) oil pressure indicator												
	Red line	266 F (130°C) oil temperature indicator												
	Red line	248 F (120°C) water temperature indicator												
Stainless steel fireproof identification plate	Aircraft Type MC Flight Design GmbH s/n Date Manufactured	on the airframe inside the engine compartment or the left side rear fuselage near the stabilator												
Calibration card	after calibration	below the compass												
Warnings and load limits	<p style="text-align: center;"><b>Warnings:</b></p> <p style="text-align: center;"><b>Do not remove safety belts in flight</b></p> <table border="1"> <tr> <td rowspan="3">Read manuals before flight</td> <td>max takeoff weight</td> <td>..... kg</td> </tr> <tr> <td>max cabin load</td> <td>..... kg</td> </tr> <tr> <td>max cabin load at full fuel</td> <td>..... kg</td> </tr> </table>	Read manuals before flight	max takeoff weight	..... kg	max cabin load	..... kg	max cabin load at full fuel	..... kg	upper half central instrument panel					
Read manuals before flight	max takeoff weight		..... kg											
	max cabin load		..... kg											
	max cabin load at full fuel	..... kg												
Warnings	<p style="text-align: center;"><b>Warnings</b></p> <p style="text-align: center;"><b>Manoeuvre speed 100 kt / 185 km/h IAS</b></p> <p style="text-align: center;"><b>No intentional spins</b></p> <p style="text-align: center;"><b>Aerobatics prohibited</b></p>	left instrument panel												
Take-off checklist summary		left instrument panel												
<p><b>Takeoff Checklist Summary</b></p> <table border="1"> <tr> <td>Pre-flight Checklist..... confirm complete</td> <td>Fuel Quantity .....confirm checked</td> <td>Choke, Carb Heat .....confirm off</td> </tr> <tr> <td>All Doors .....confirm closed</td> <td>Fuel Valve .....confirm open</td> <td>Flight Controls .....confirm checked</td> </tr> <tr> <td>Safety Belts .....confirm fastened</td> <td>Before Takeoff Checklist ...confirm complete</td> <td>Flaps .....confirm set</td> </tr> <tr> <td></td> <td>Pitch Trim .....confirm neutral</td> <td>Parachute .....confirm armed</td> </tr> </table> <p style="text-align: center;"><b>Warning: Checklist summary only. Complete checklists by manual are mandatory!</b></p>			Pre-flight Checklist..... confirm complete	Fuel Quantity .....confirm checked	Choke, Carb Heat .....confirm off	All Doors .....confirm closed	Fuel Valve .....confirm open	Flight Controls .....confirm checked	Safety Belts .....confirm fastened	Before Takeoff Checklist ...confirm complete	Flaps .....confirm set		Pitch Trim .....confirm neutral	Parachute .....confirm armed
Pre-flight Checklist..... confirm complete	Fuel Quantity .....confirm checked	Choke, Carb Heat .....confirm off												
All Doors .....confirm closed	Fuel Valve .....confirm open	Flight Controls .....confirm checked												
Safety Belts .....confirm fastened	Before Takeoff Checklist ...confirm complete	Flaps .....confirm set												
	Pitch Trim .....confirm neutral	Parachute .....confirm armed												
Warning	avionics off before engine start or stop	Instrument panel, low center												
Fuel grade	<p style="text-align: center;"><b>Fuel</b></p> <p style="text-align: center;">MINIMUM 91 Octane Auto Fuel or 100 LL AvGas</p> <p style="text-align: center;">13.2 Gallons Per Side (12.8 Useable)</p>	adjacent to each fuel tank filler cap												
	<p style="text-align: center;">◀ Full <b>Throttle</b> Idle ▶</p>	adjacent to throttle												
	<p style="text-align: center;">◀ Off <b>Choke</b> On ▶</p>	adjacent to choke												
	<p style="text-align: center;">◀ Off <b>Brake</b> On ▶</p>	adjacent to brake lever												



Flap position	-12°, 0°, 15°, 30°, 35°	flap selection lever
Oil grade and amount		inspection engine cowling flap
Circuit breakers	Main circuit breakers according to function	instrument panel
Master switch	Batt	instrument panel
Alternator switch	Gen	instrument panel
Packing interval	according to recovery system handbook	recovery system handbook and on recovery system
Baggage payload		Posted on both sides of the baggage compartment
Baggage payload, hat rack		Posted on both sides of the hat rack, at the back
Warning		Posted on all sides of the baggage compartment
Door opening instructions		Posted on the outside of each door
		Posted on the inside of each door handle
Warning	„Danger“	Parachute recovery system hatch
Warning	Recovery system, only in an emergency! 1.) switch off engine 2.) deploy recovery system 3.) protect yourself	Posted near the actuation handle for the parachute recovery system
Warning	Observe towing speed	Posted near the airspeed indicator if tow hook installed

## 8. HANDLING AND SERVICING

**Warning:** Attention must be paid to the proper securing of the recovery system during any servicing or repair work to ensure that it is not inadvertently activated (ensure that the activation handle is secured with the safety pin inserted).

### 8.1. Jacking

The jacking of the MC aircraft requires special care. The outer shape is provided by light weight composite fairings that are in no way designed to take jacking loads. So usage of support cushions on the area is no appropriate means to jack the MC, and will result in fairing and attachment point damages.

There are two possibilities to lift off the aircraft from the ground. When work has to be done that requires the landing gear legs unloaded, the aircraft shall be lifted with padded supports set under the wing main spar, directly outside the wing strut attachment. See area marked in figure below.

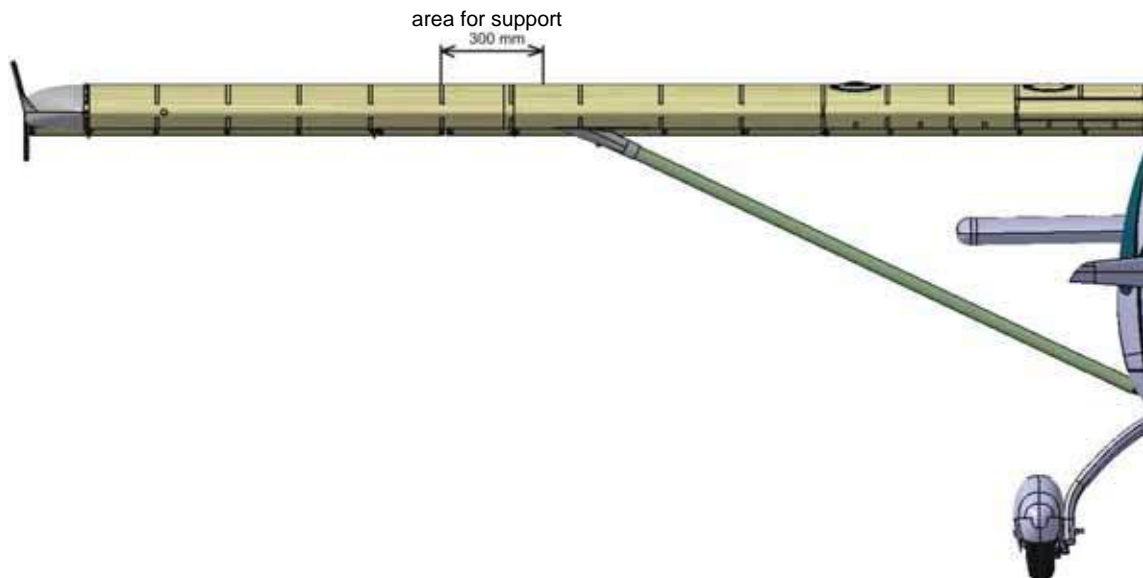

**Warning:** When applying jacks under the wing make absolutely sure that the padded surface only supports exactly at the spar position. Otherwise the high loads will push the wing skin inside. This can in addition easily damage the ribs inside the wings.

When work has to be done only on the main wheels and the gear legs need not be unloaded, a simpler method can be chosen. Set parking brake and block the wheel that remains on the ground with chocks. The wheel fairing must be removed first at the side that shall be lifted off the ground. The aircraft can then be lifted off the ground on the appropriate side. An assistant holds the aircraft in the area of the strut attachment on the wing under the spar (same area as above. Same warning applies; be very careful to really only push under the spar, as otherwise the wing skin and the ribs below can be damaged from the high local load) and lifts the wing slightly. As soon as the wheel is free, a wooden block is placed under the lower end of the landing gear strut.





## Aircraft Operating Instructions (AOI)

Type: *MC*

Series: *MC-LSA*

Page: 8-2

**Warning:** Only use a wooden block to support the main gear leg. Metal jacks can damage the composite structure of the gear leg. Make sure that the leg is supported not on a single point.

**Warning:** Be careful not to damage the brake caliper.

Work on the main wheel can now be conducted. When using this method, only lift one side at a time.

A second simplified method is available when work needs to be done at the nose wheel only. In this case the aircraft remains standing on the main wheels. Using a belt around the tail fuselage (in the area of a bulkhead – refer to the rivet lines) and ballast (e.g. a jerry-can filled with water), the tail is held down until the nose wheel is free. Never try to jack the aircraft under the firewall – this area is not designed to take the resulting forces.

### **8.2. Securing the aircraft for road transportation**

Road transport is only allowed by qualified mechanics. Necessary procedures for assembly and disassembly are given in the separate MC LSA Maintenance and Inspection Manual.

### **8.3. Parachute recovery system maintenance**

The parachute recovery system requires no maintenance, except observance of the pack intervals for the parachute and the exchange intervals for the rocket. These intervals are recorded in the recovery system handbook.

The recovery system should only be removed from the aircraft by an authorized workshop. Depending upon national regulations, special approval may be required to handle the recovery system rocket.

### **8.4. Cleaning and care**

Each aircraft must be cleaned with caution. Please select cleaners that are specifically developed for aircraft use.

**Warning:** High-pressure washer equipment should never be used to clean the aircraft!

#### **8.4.1. Airframe**

The metal parts of the airframe (tail fuselage, wings, stabilizer) can be cleaned conventionally with water, pure or with addition of mild washing agents.

As the MC structure is made of Aluminum and Steel it is robust against cleaning agents. Care must be taken when cleaning the composite fuselage fairings, such as around the cabin. Please only use composite specific cleaning agents in this area to avoid damages.

#### **8.4.2. Windshield and windows**

The windshield and windows of the MC are made of perspex (plexiglass, acrylic glass) which was formed at high temperatures. Although perspex is very robust, it must be cleaned with care to ensure that it is not scratched. Never use abrasive cleaning agents or dirty cloths. Usually the windshield and windows can be cleaned using lots of clean water. However, if dirt is stubborn, perspex cleaning agents only should be used.

Only use special perspex polish for the windshield and windows. Never polish in a circular movement, always in straight lines (up and down or from side to side). This prevents the



## Aircraft Operating Instructions (AOI)

Type: *MC*

Series: *MC*-LSA

Page: 8-3

occurrence of the disturbing halo effect caused by circular scratches. Light scratching can usually be polished out by your Flight Design service station.

Make sure that you never leave solvent-soaked cleaning cloths under the windshield or near the windows. Vapors can quickly lead to small stress cracks in the glass. A windshield or windows damaged in this way cannot be repaired and must be replaced.

### 8.4.3. Power plant

The Rotax 912 series engine operating handbook recommends the use of a standard degreaser. Please follow the instructions given in the operating handbook and make sure that the degreaser does not come in contact with the airframe.

**Warning:** If a moisture-based cleaning agent is used on the engine, the electronics must be protected from getting damp. High-pressure cleaning devices should never be used to clean the engine.

### 8.5. Mandatory aircraft inspections

The following inspections are a minimum requirement for the maintenance of the aircraft:

25 h inspection (engine only):

It is carried out only once on new aircraft after they have clocked the first 25 hours of operation. It must also be carried out 25 hours after a major overhaul.

100 h inspection (or annual):

This inspection must be carried out at least once a year even if the aircraft is not operated for 100 hours during the calendar year. The interval to the next inspection starts with this advanced inspection.

200 h inspection:

The same as the 100 h inspection, this inspection can be brought forward when fewer hours have been flown. It is performed at every other 100 h inspection.

The TBO times for the engine and propeller must also be observed. Provision is made for these items in the 100 h and 200 h inspection lists.

The current maintenance list as required by the engine manufacturer is mandatory for engine maintenance. The inspection items listed here give only general conditions indication frequency of whole installation, not of the engine itself.

These inspections do not supersede any mandatory airworthiness inspections required by the national aviation authority of the country in which the aircraft is registered.

The record of the inspections must be documented. A copy of following list in which the points are ticked off or appropriate notes should be kept as a record.

The detailed maintenance procedures for the MC LSA version are described in a separate Maintenance and Inspection Manual. The MC is a modern and somewhat complex machine which requires specific training for proper maintenance. We, therefore recommend that the 100 h inspections be carried out at Flight Design approved repair station if possible. Besides that for all maintenance steps the minimum qualification requirements for the repairman are defined.



## Aircraft Operating Instructions (AOI)

Type: **MC**

Series: **MC-LSA**

Page: 8-4

### 8.6. Repairs to the airframe

**Warning:** Minor repairs on non-lifting parts may only be carried out by qualified personnel approved by the manufacturer.

**Warning:** Major repairs, particularly after accidents, may only be carried out by the manufacturer or by a Flight Design authorized aviation workshop.

Original materials only should be used for repair work. Should you discover structural damage, please contact a Flight Design service station or a workshop qualified to undertake such repair work. Should this not be possible, please contact Flight Design at the valid service mail address listed on the website. Based on your description of the damage, we shall make recommendations as to what you should do. You will also receive precise repair instructions and documents showing exact structural details for the part of the aircraft affected.

#### 8.6.1. Lubricants and operating fluids

Brake fluid

Aeroshell Fluid 41 MIL-H-5606 Brake Fluid. Use only this type red aircraft fluid or other suitable petroleum or silicone based fluid.

**Warning:** Due to the material of the sealings in the brake system (Buna Nitrile) usage of automotive glycol based brake fluid is strictly prohibited, as it will damage the sealings.

Coolant

Glysantine/water mixture (50 : 50) in accordance with the instructions in the engine operating handbook.

**Warning:** Anti-freeze from different manufacturers must not be mixed as they may react with each other and flocculate. If in doubt, the mixture should be completely drained off and replaced. Flight Design uses BASF Protect Plus, as recommended by Rotax. If the anti-freeze is changed, an aluminum-compatible anti-freeze recommended by Rotax should be used.

**Warning:** Flight Design advises against the use of Evans coolant. The advantages offered by this fluid are negated by sustained operational problems (e.g. moisture absorption). Based on the results of testing under various climatic conditions, it has been demonstrated that Evans is not necessary for the safe operation of the MC.

Engine oil  
Fuel

in accordance with the Rotax manual  
EN 228 Super or Super Plus  
91 AKTI (octane) premium unleaded auto  
AVGAS 100 LL

**Warning:** Not every oil type is suited to engine operation with AVGAS or MOGAS. Refer to the relevant version of the Rotax engine manual for detailed information on suitable oil types. The list of suitable engine oils is constantly adjusted according to availability. It is, therefore, recommended you consult the current list on the Rotax Service Bulletins website.

Hydraulic fluid, variable pitch propeller DOT 4 SAE J1703 /FMVSS 116



## Aircraft Operating Instructions (AOI)

Type: *MC*

Series: *MC-LSA*

Page: 8-5

Lubricant, wing and strut attachments    Heavy duty grease WGF 130 DIN 51502  
Lubricant, bearings, rod ends            GLEITMO 805, Mobilux EP 2 or any lithium  
based grease

**Warning:**    The plastic bearings on the flaps and the ailerons are maintenance-free and should not be greased.

### **8.7. Control surface deflections**

The settings of the control surfaces and the wing flaps greatly influence aircraft characteristics. The correct surface deflections, and the procedure to adjust the system, are defined within the Aircraft Maintenance Manual.



## Aircraft Operating Instructions (AOI)

Type: *MC*

Series: *MC*-LSA

Page: 9-1

### 9. SUPPLEMENTS

#### 9.1. *Sailplane tow*

At this point of time the flight testing for sailplane towing is not yet finished.

Your local Flight Design Dealer can inform you when this part of the certification is finished. Your Flight Design dealer can also provide you with the revised manual, containing all instructions for glider towing, once released.

#### 9.2. *Banner tow*

Banner towing is not allowed in all countries.

At this point of time the flight testing for banner towing is not yet finished.

Your local Flight Design Dealer can inform you when this part of the certification is finished. Your Flight Design dealer can also provide you with the revised manual, containing all instructions for glider towing, once released.



## Aircraft Operating Instructions (AOI)

Type: *MC*

Series: *MC*-LSA

Page: AI - 1

### APPENDICES

#### Appendix 1 – Current Weighing Report

The current weighing report should be inserted here. Old weighing reports should be kept so that the history of the aircraft is properly documented. They should be marked by hand with the word “INVALID”. The owner of the aircraft is responsible for ensuring that a valid weighing report is made available.



## Aircraft Operating Instructions (AOI)

Type: *MC*

Series: *MC*-LSA

Page: AI - 2

### Appendix 2 – Current Equipment List

The current equipment list should be inserted here. Old equipment lists should be kept so that the history of the aircraft is properly documented. They should be marked by hand with the word “INVALID”. The owner of the aircraft is responsible for ensuring that a valid equipment list is available.

	<b>Aircraft Operating Instructions (AOI)</b>		
	Type: <b><i>MC</i></b>	Series: <b><i>MC-LSA</i></b>	Page: <b>AI - 3</b>

**Appendix 3 – Safety Flight Report Form**

<p>Flight Design USA Safety of Flight Report</p> <p>Number: _____</p> <p>Received: _____</p>		<p><b>Flight Design USA</b>          P.O. Box 325          91 Route 169          South Woodstock Ct, 06267          airworthiness@flightdesignusa.com          www.flightdesignusa.com</p>
Person Reporting: _____		
Contact Information: _____		
Time and Location: _____		
Aircraft/Engine Model and SN: _____		
Total Time Airframe/Engine: _____		
Description of Event: _____ _____ _____ _____ _____ _____ _____ _____ _____ _____ _____ _____ _____ _____ _____ _____ _____ _____		

FDUSA SFR Ver.1.1

AA 04300001	Revision No. 00	Date: 10 July 2009
-------------	-----------------	--------------------



## Appendix 4 - Electrical system

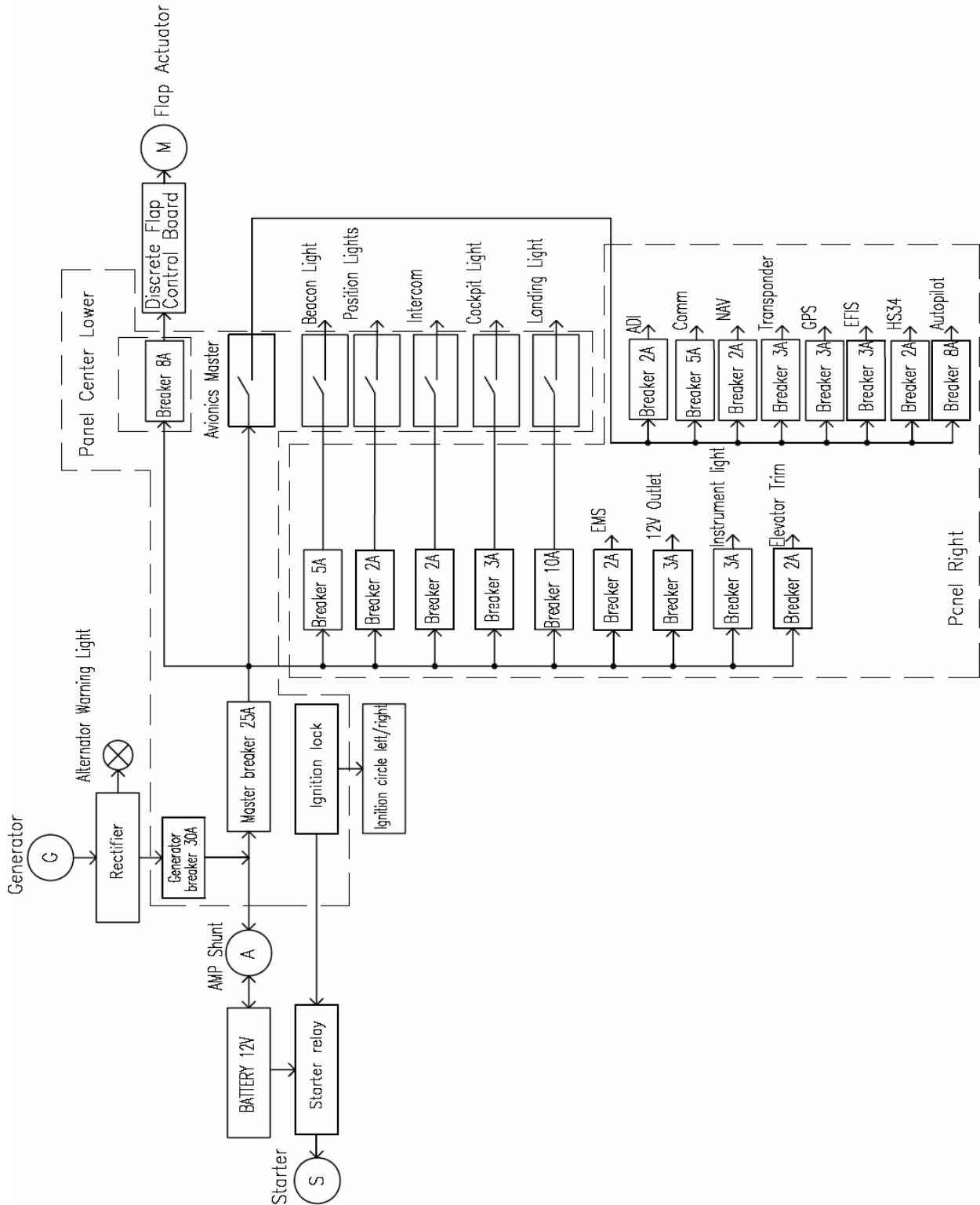

MC block diagram – Power bus supply

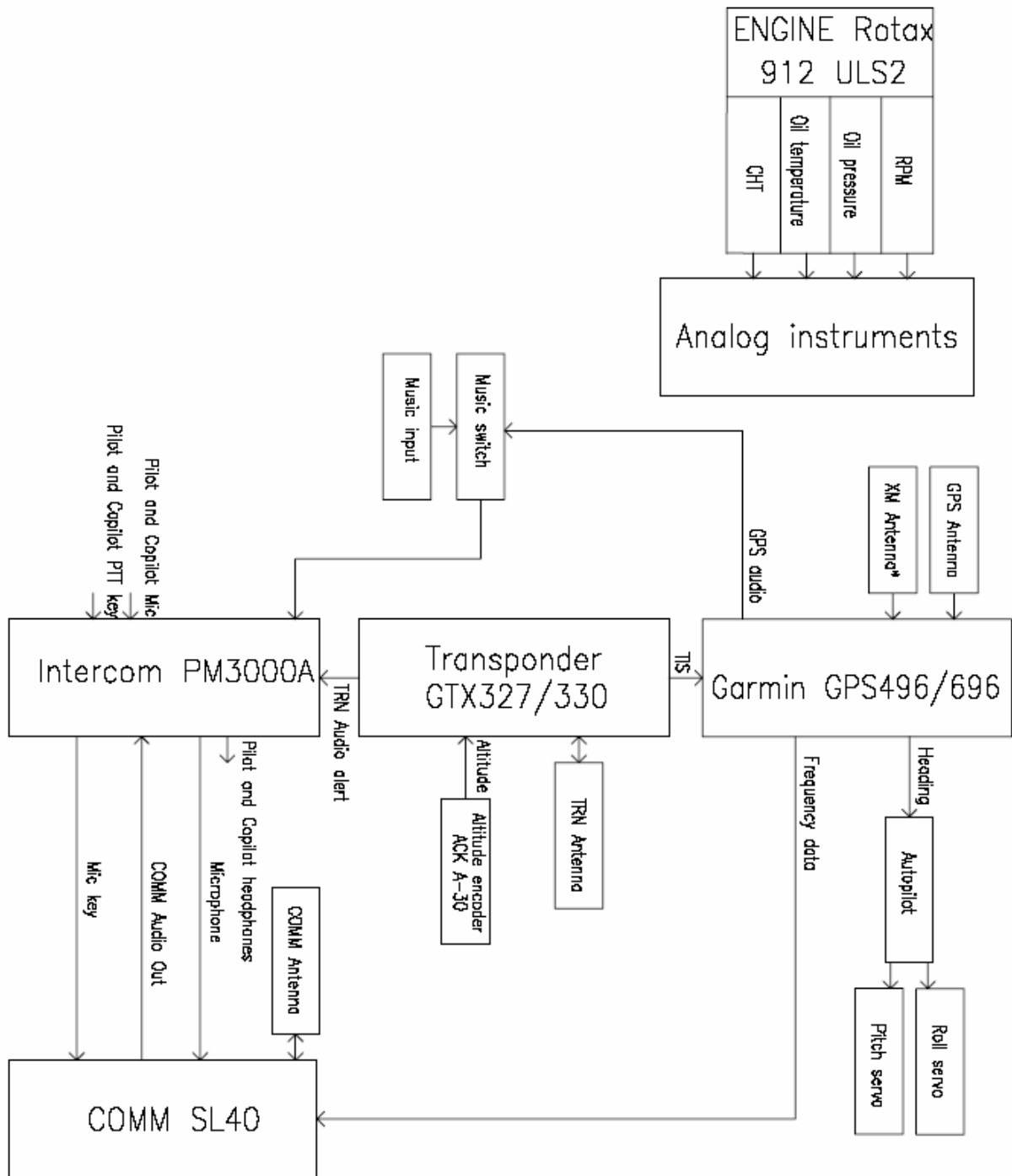

MC block diagram – Classic + SL 40 Avionic

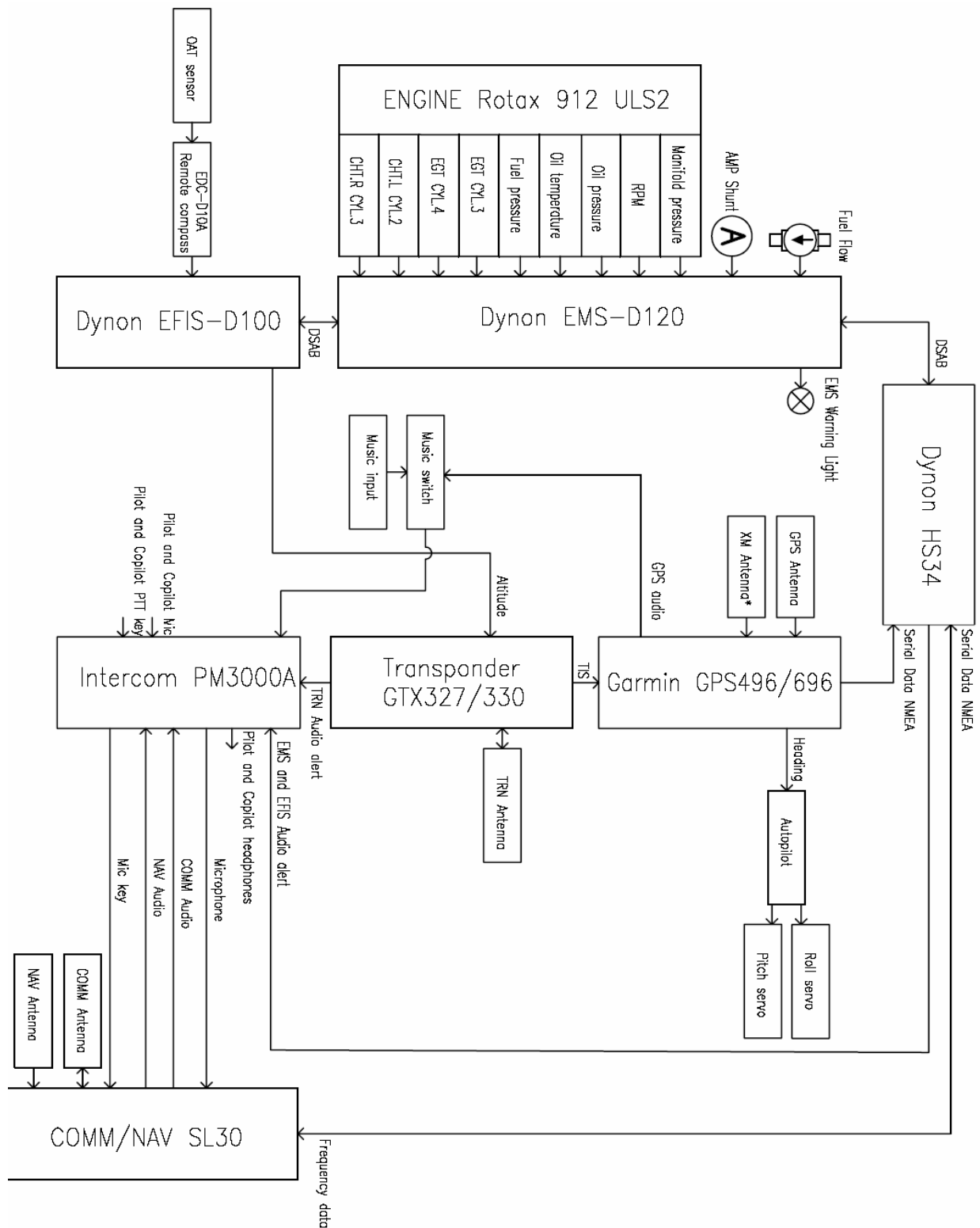

MC block diagram – D100+D120+SL30 Avionic

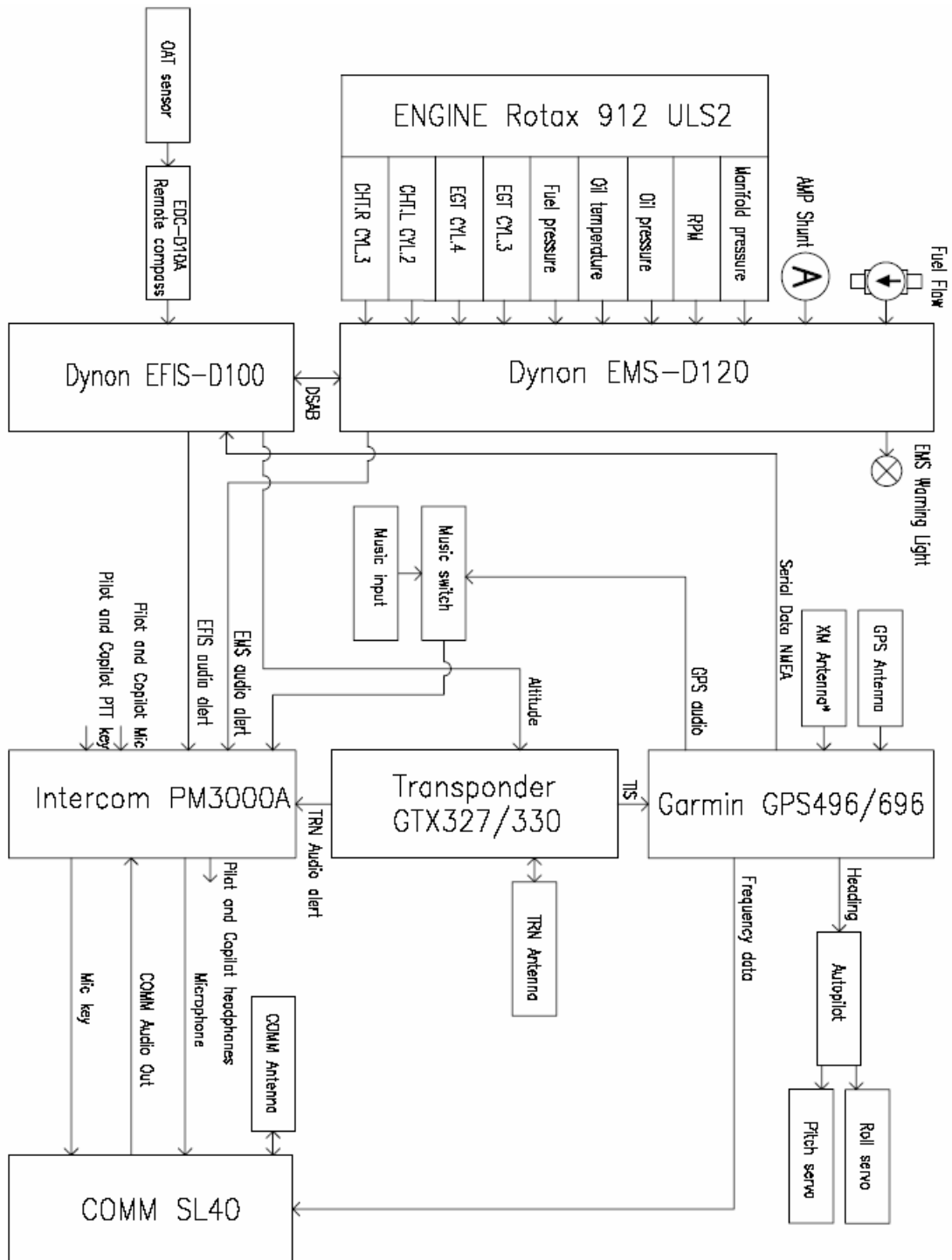

MC block diagram – D100+D120+SL40 Avionic

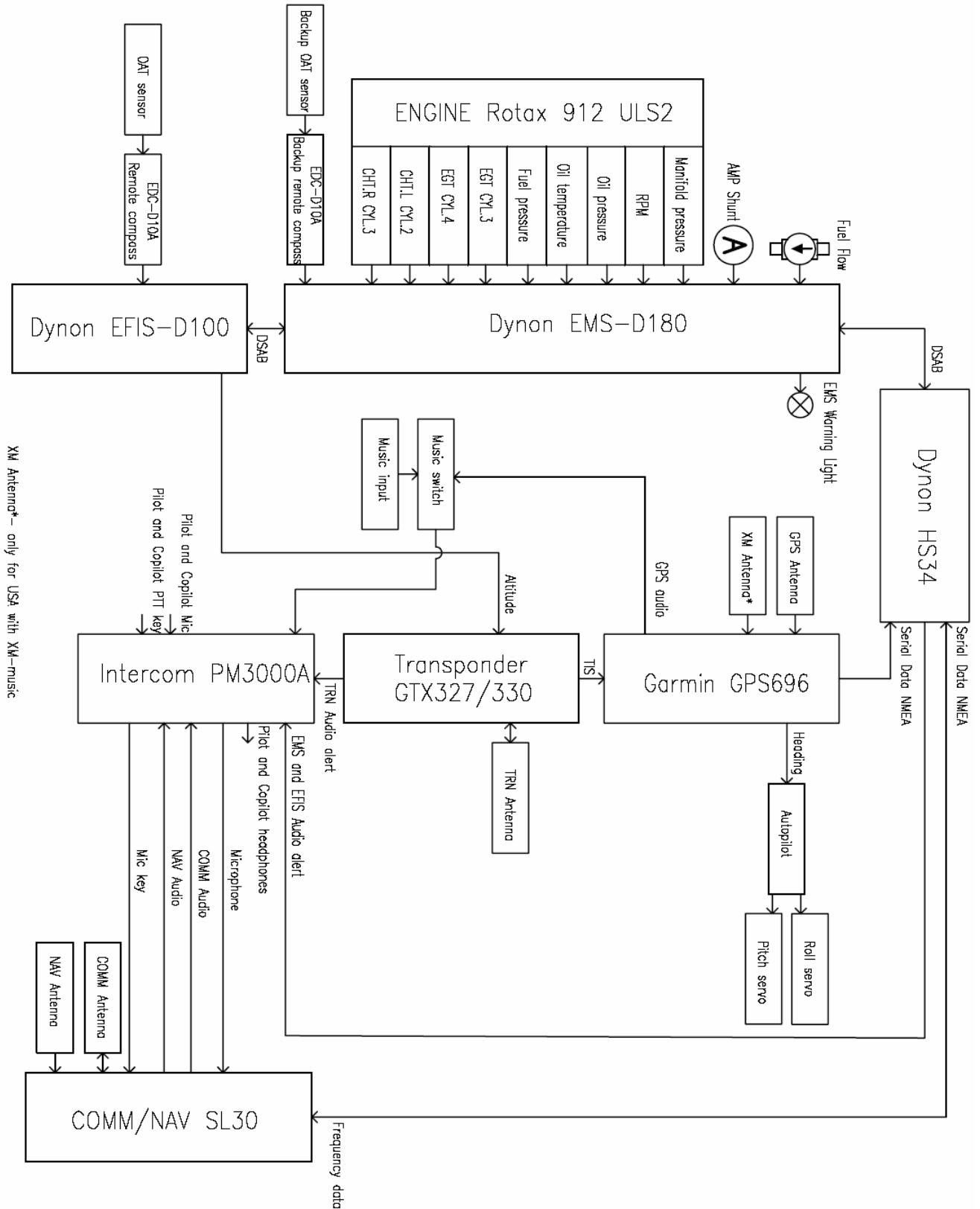

XM Antenna\* - only for USA with XM-music

MC block diagram -D100+D180+SL30 Avionic

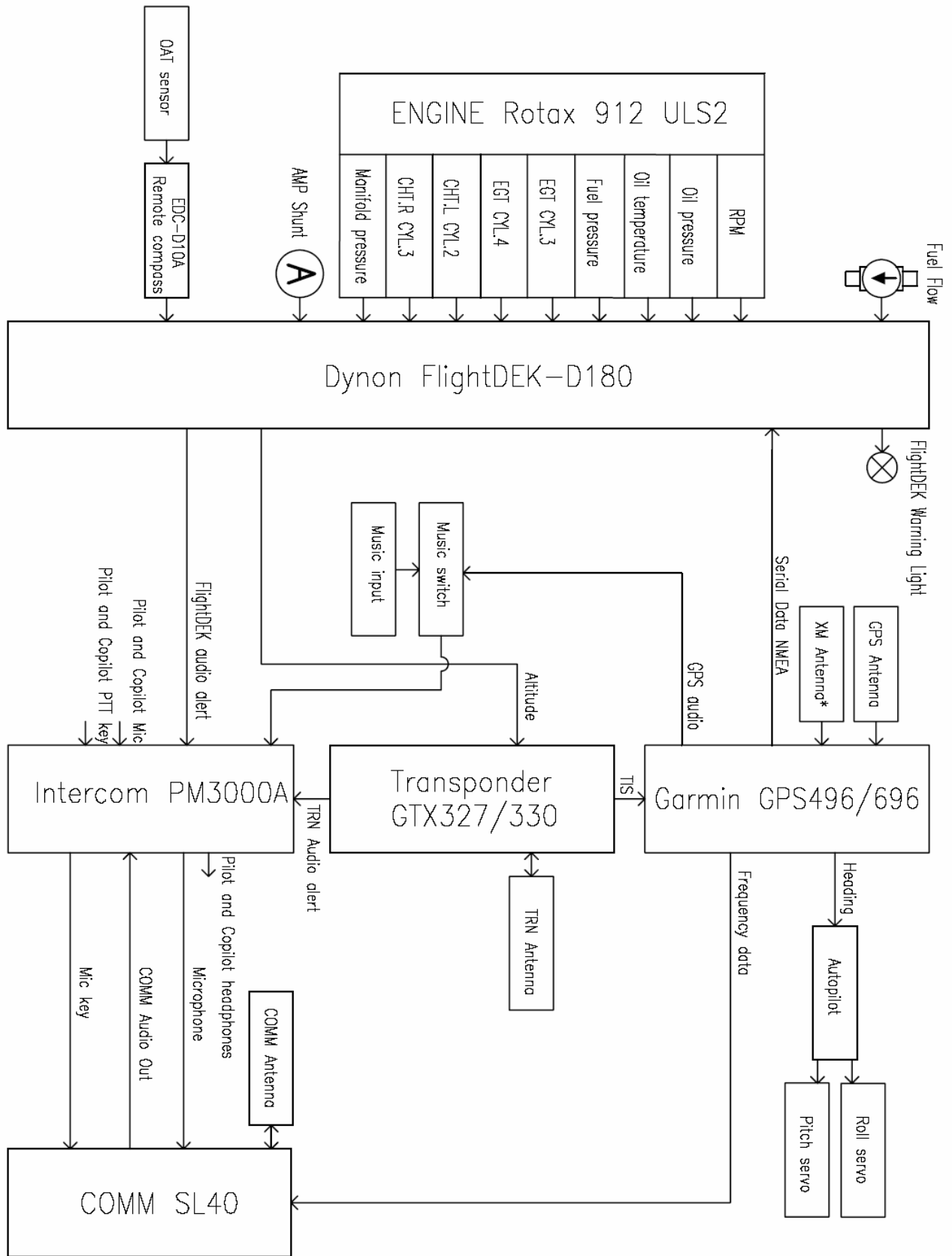

MC block diagram – D180+SL40 Avionic

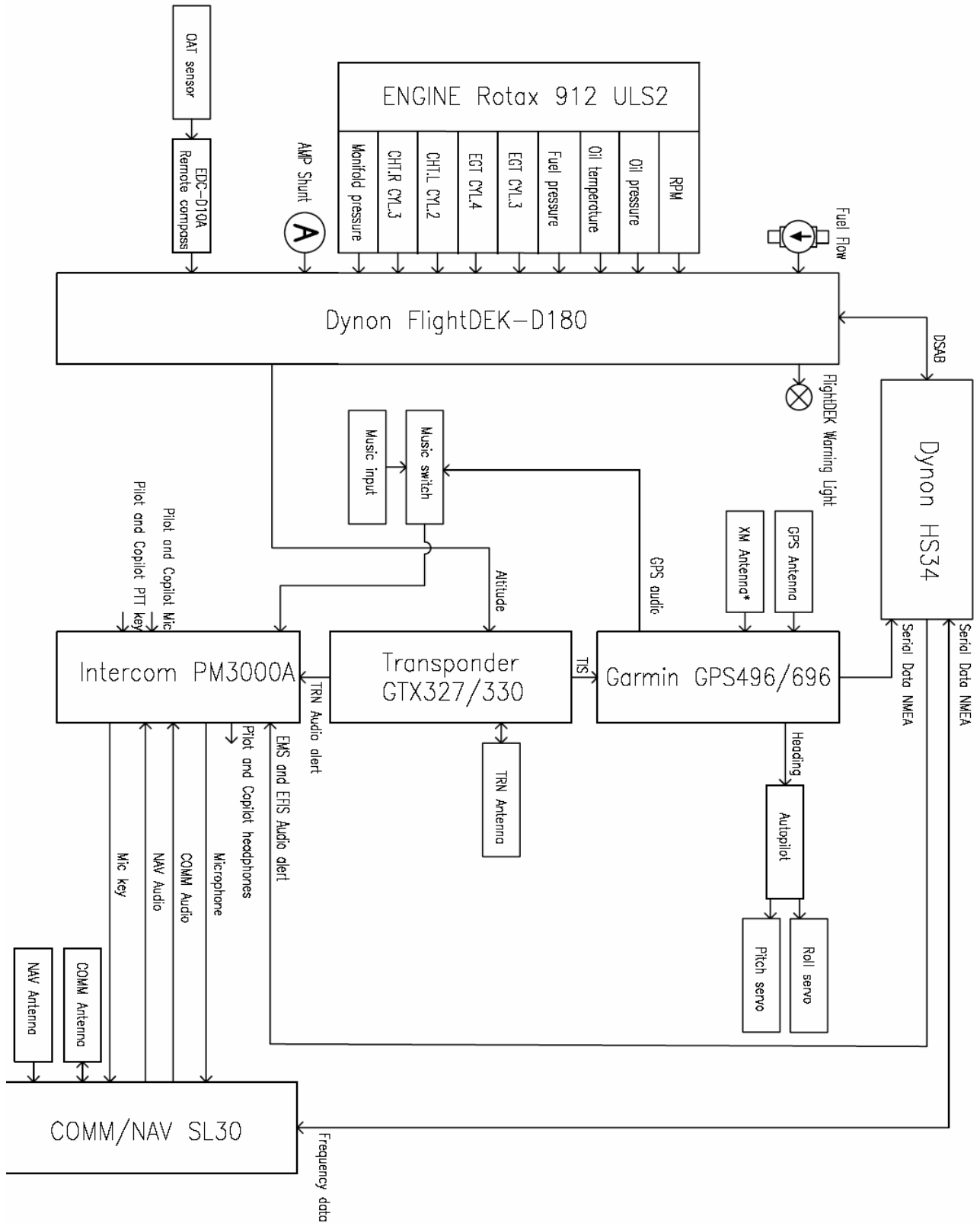

MC block diagram – D180+SL30 Avionic